



## DUCATI DIAVEL DYNAMIC TAIL TIDY

Product Reference - 9644

### Kit Contents

- |                                      |                                                 |
|--------------------------------------|-------------------------------------------------|
| <b>A</b> 1 x Central Grab Rail Arm   | <b>M</b> 2 x M8 - 16 Socket Button Head Screws  |
| <b>B</b> 1 x LH Rail Slider Plate    | <b>N</b> 2 x M8 Custom Washers                  |
| <b>C</b> 1 x RH Rail Slider Plate    | <b>O</b> 2 x M6 - 20 Socket Cap Head Screws     |
| <b>D</b> 1 x Grab Rail               | <b>P</b> 2 x M6 - 16 Centre Hole Trunions       |
| <b>E</b> 1 x LH Cover Plate          | <b>Q</b> 2 x M6 Black Cover Caps                |
| <b>F</b> 1 x RH Cover Plate          | <b>R</b> 2 x M4 - 16 Socket Countersink Screws  |
| <b>G</b> 1 x Licence Plate Holder    | <b>S</b> 2 x M4 - Centre Hole Trunions          |
| <b>H</b> 1 x Licence Plate Light     | <b>T</b> 2 x M3 - 12 Socket Button Head Screws  |
| <b>I</b> 1 x Reflector               | <b>U</b> 2 x Pairs of Bullet Connectors         |
| <b>J</b> 1 x Reflector Bracket       | <b>V</b> 6 x Cable Ties                         |
| <b>K</b> 1 x Wiring Loom Connector   | <b>W</b> 16 x M4 - 10 Socket Countersink Screws |
| <b>L</b> 2 x Plastic Screws and Nuts |                                                 |

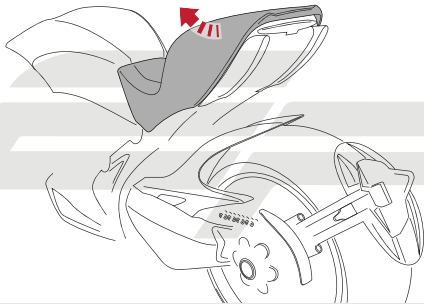

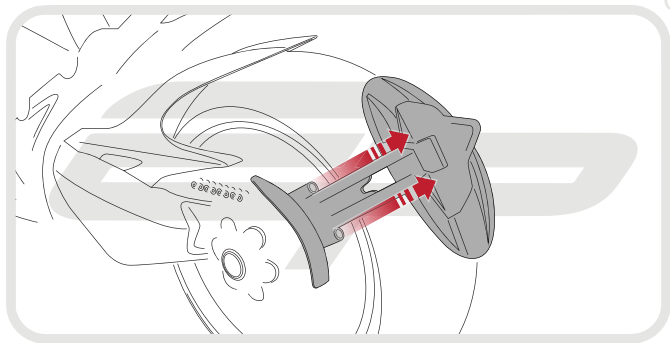

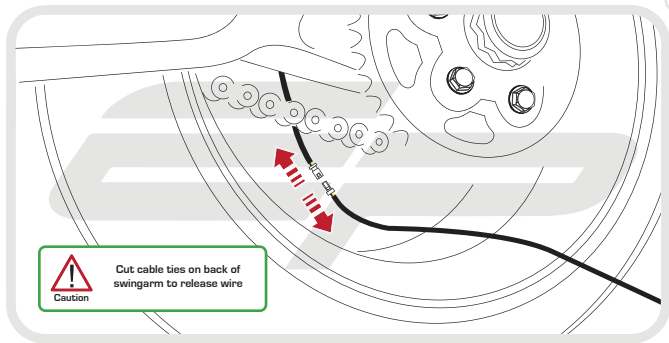

Caution

Cut cable ties on back of swingarm to release wire

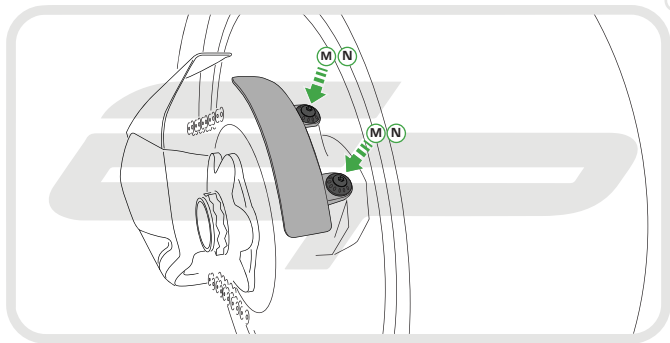

**EVOTECH**<sup>®</sup>  
P E R F O R M A N C E

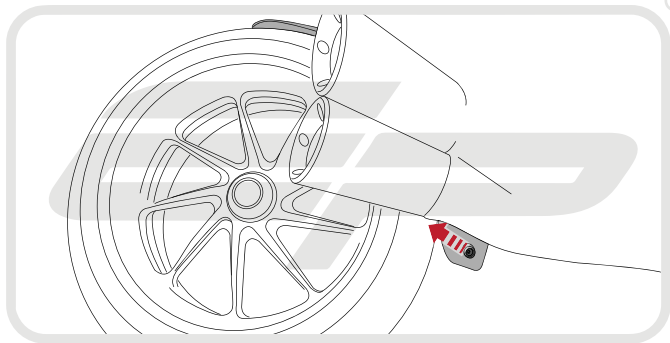

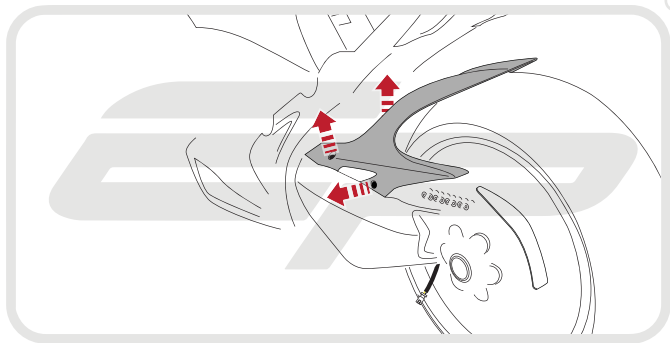



Lift chain guide so that the wire  
can be released from underneath

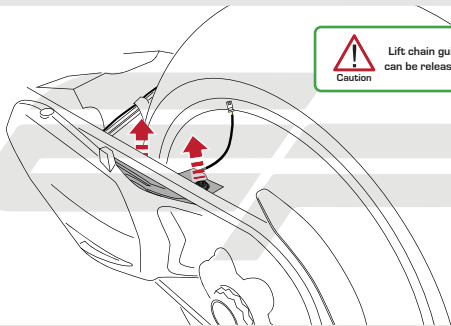





Caution

Re-fit chain guide ensuring  
brake line and cables are neatly  
tucked underneath

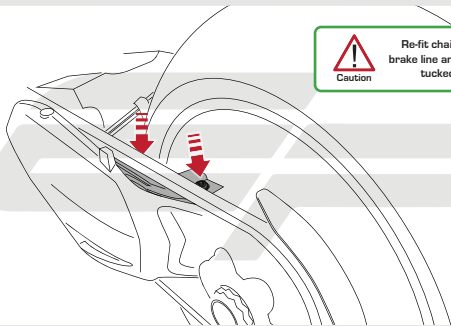

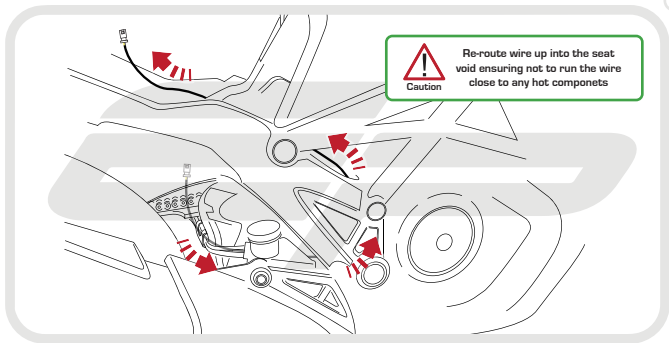

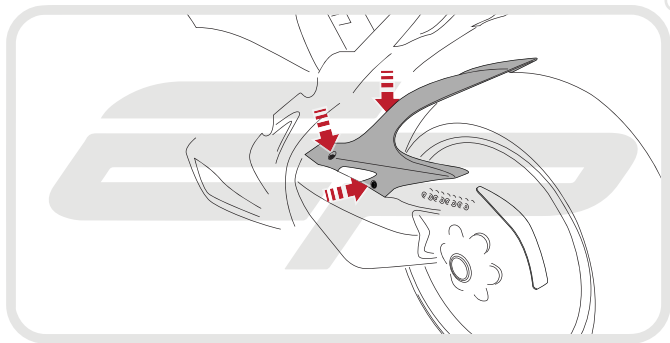

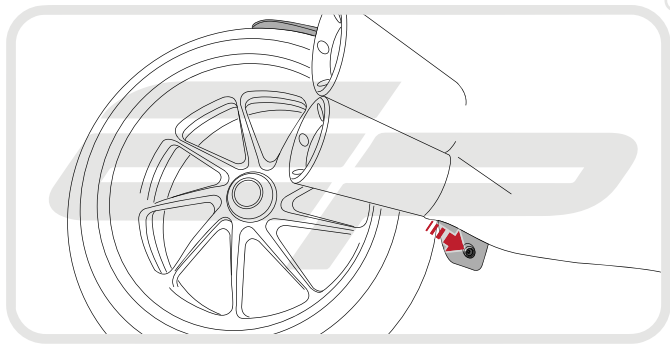

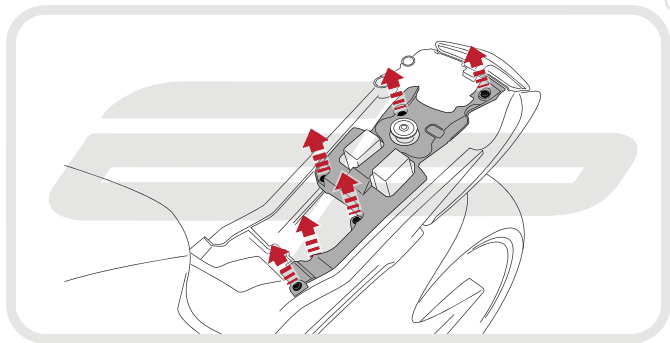

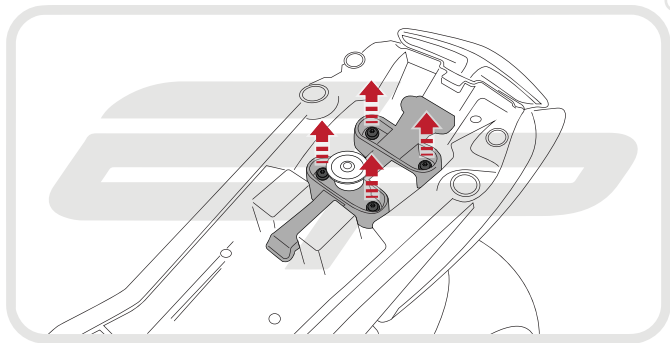

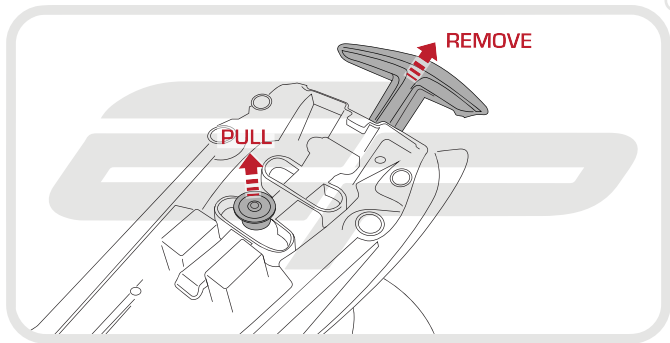

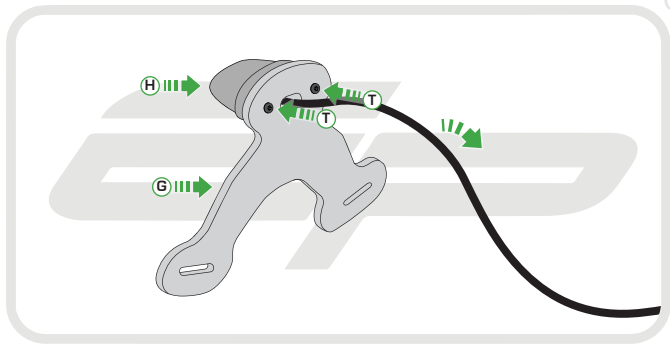



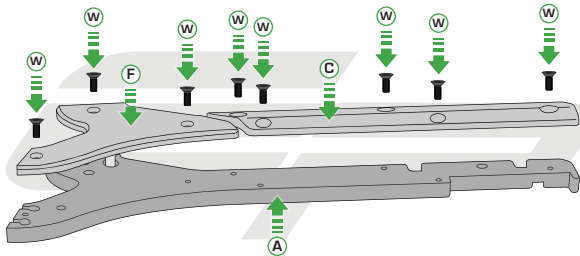

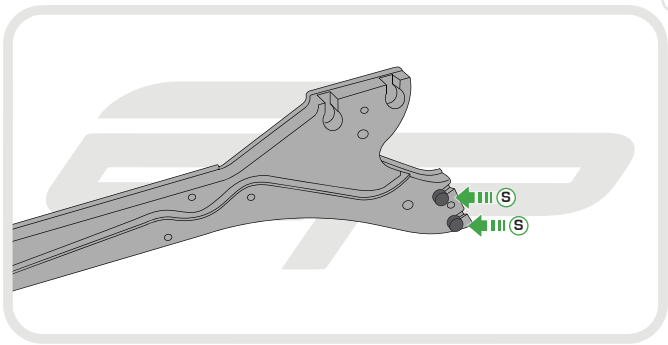

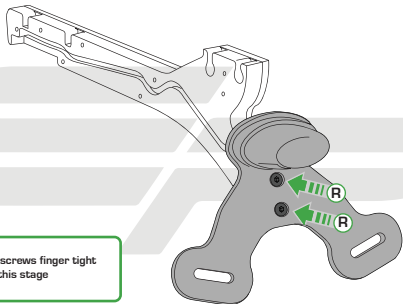

Caution

Only tighten screws finger tight  
at this stage



Caution

Only insert screw 2 turns  
at this stage as they are only  
to line up the trunions

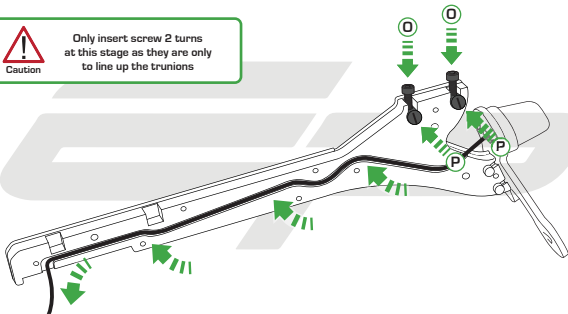

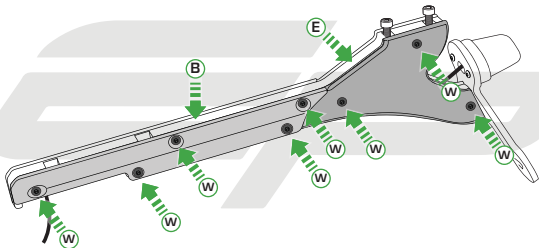



Caution

Once all other screws are fully tightened, carefully remove screws from trunions ensuring the trunions do not rotate

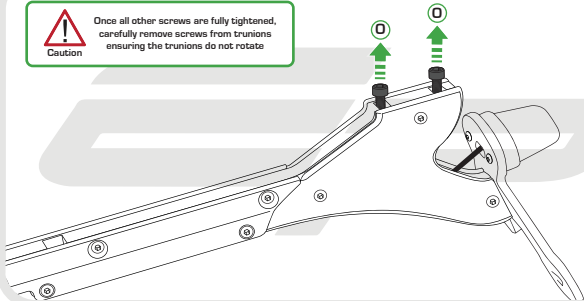



Caution

Ensure Grab Rail is fully located onto central rails before tightening

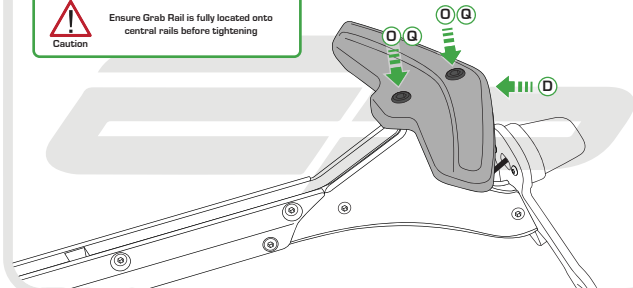



Caution

Apply a generous amount of grease  
to both sides of the rail

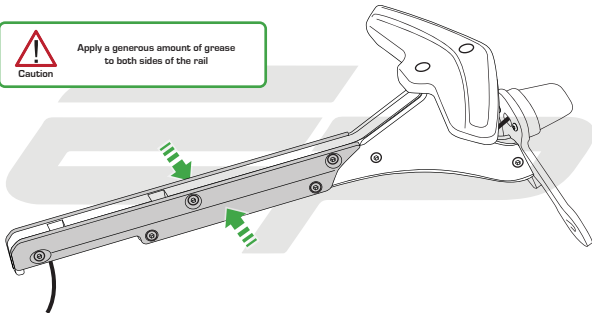





Caution

Lift grab rail cover plate out of the way and slide new tail tidy in through rubber seal

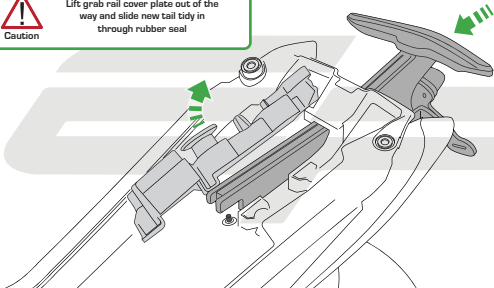

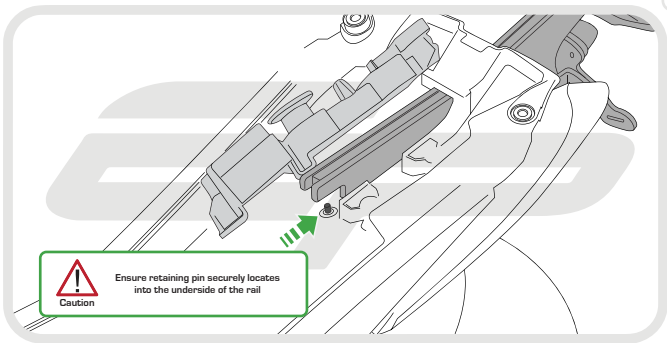

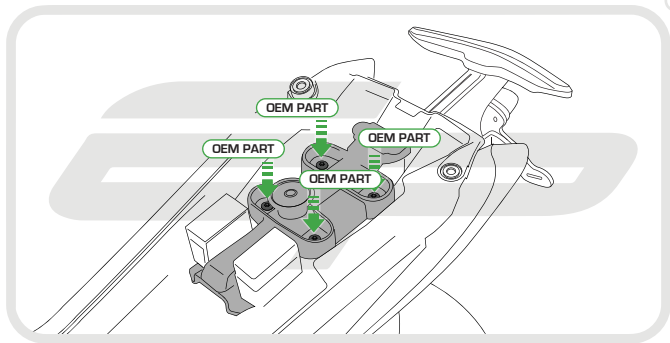



Caution

Test that the tail tidy slides in and out locking into place at both maximum and minimum positions.  
If the tail tidy pulls all of the way out then go back to stage 25 and check that the pin is correctly located

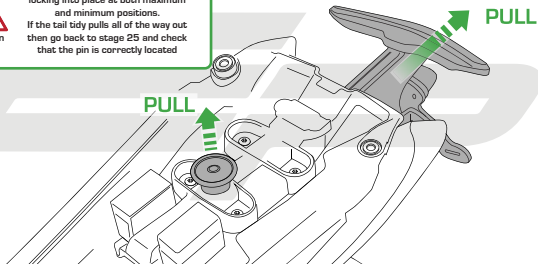

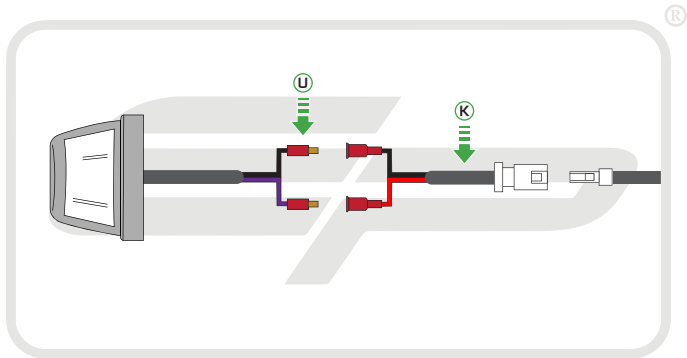

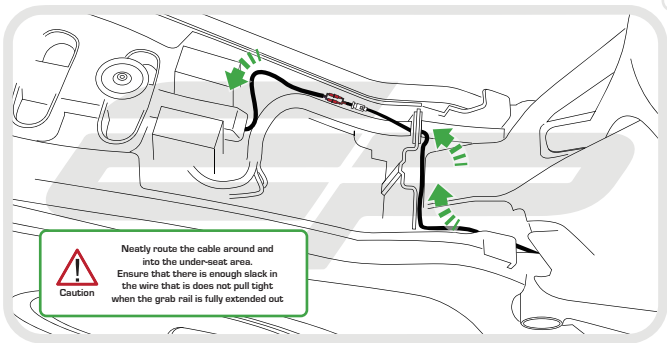

Caution

Neatly route the cable around and into the under-seat area.  
Ensure that there is enough slack in the wire that it does not pull tight when the grab rail is fully extended out



Reverse Stages  
12 and 1

## Reflector Bracket Installation

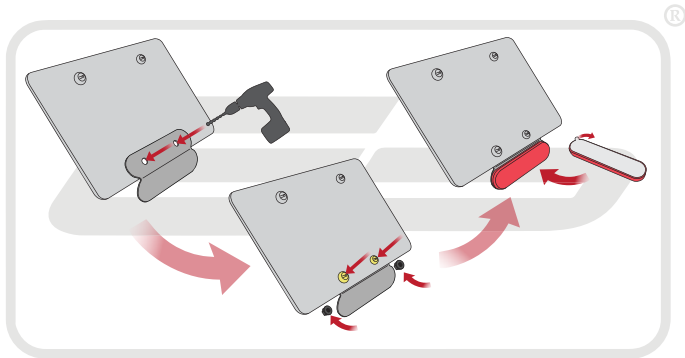

**EVOTECH**<sup>®</sup>  
P E R F O R M A N C E





## ESSENTIAL CHECKS



After installation of your tail tidy ensure that the licence plate does not contact the rear tyre when suspension is fully compressed.

Ensure all electrics including indicators, tail light, brake light and licence plate light lights are working correctly before riding the motorcycle.

It is recommended that periodic inspections are made to ensure that all fixings are fully tightend.