

APRILIA RSV4 and TUONO V4 TAIL TIDY

Product Reference - 7489

Kit Contents

- | | |
|---|--|
| A 1 x Main Tail Tidy | H 1 x M6 Spacer (not needed for this model) |
| B 1 x Licence Plate Bracket | I 2 x Plastic Screws |
| C 1 x LED Licence Plate Light | J 2 x Plastic Nuts |
| D 1 x M6 Flange Nut | K 2 x Indicator Extension Wires |
| E 1 x M6 - 30 Socket Button Head | L 6 x Pair Bullet Connectors |
| F 1 x Reflector Bracket | M 5 x M6 - 20 Socket Button Heads |
| G 1 x Reflector | N 5 x Cable Ties |

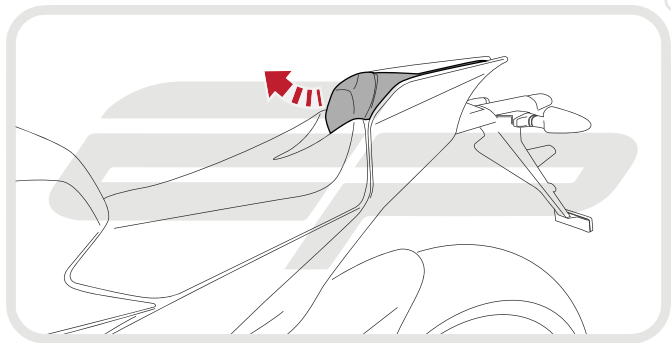

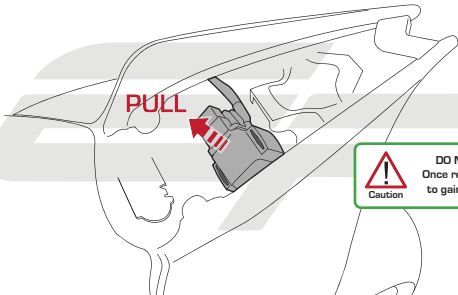

Caution

DO NOT DISCONNECT
Once released allow to float
to gain access to beneath

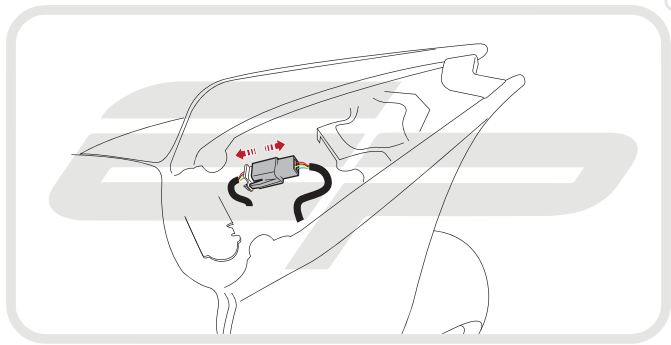

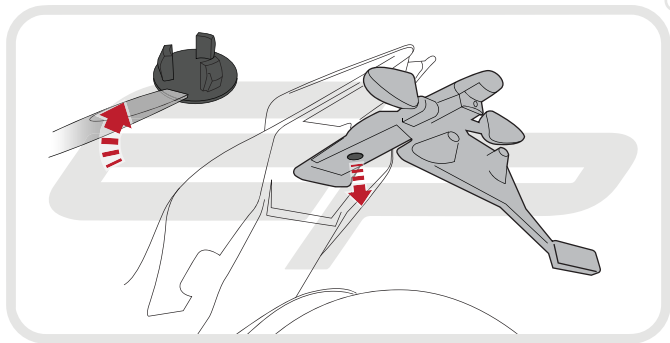

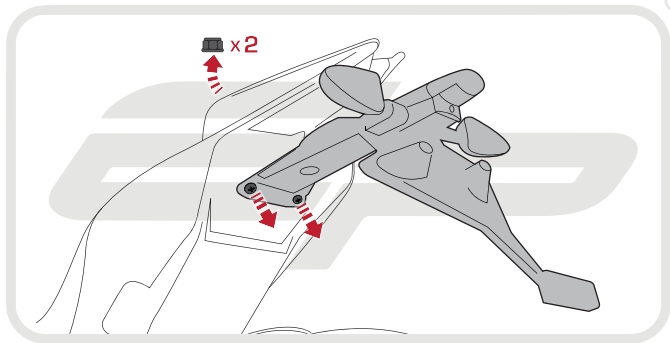

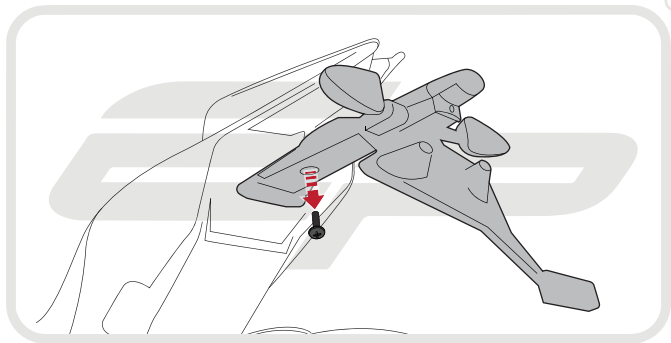

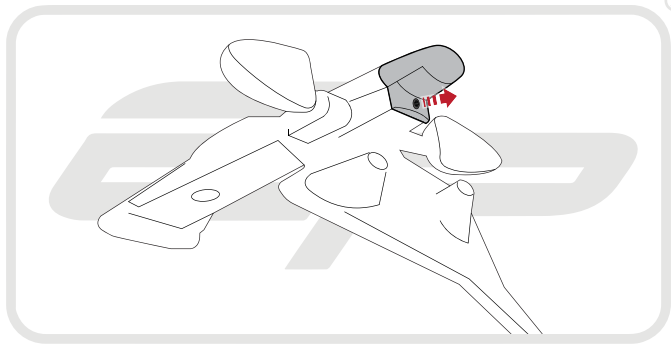

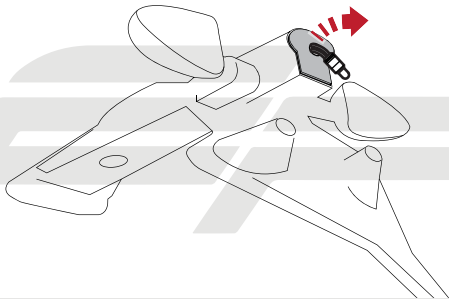

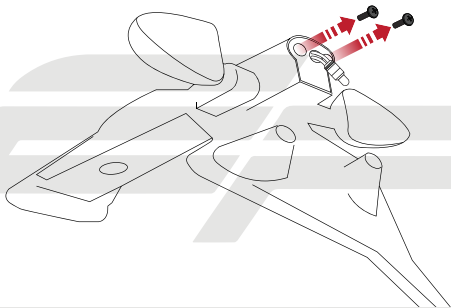

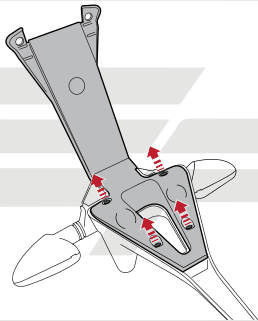

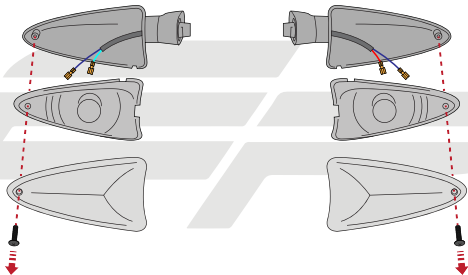

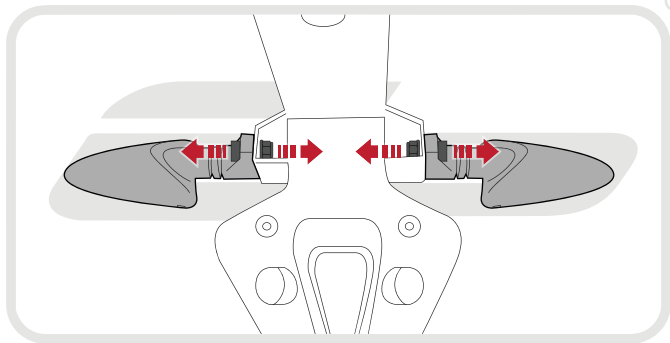

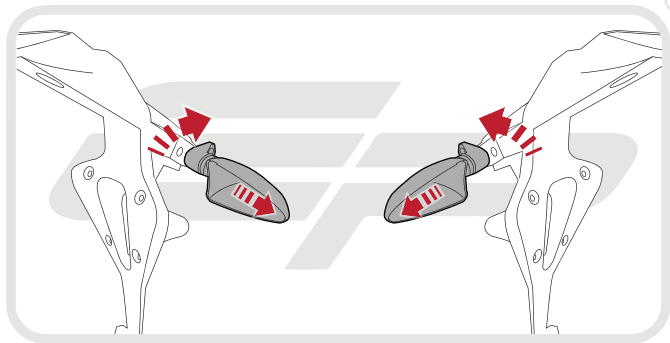

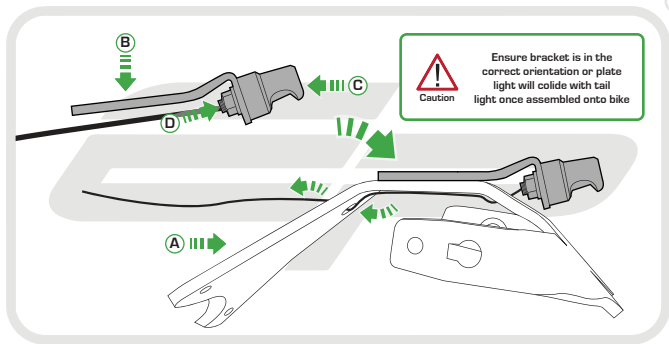

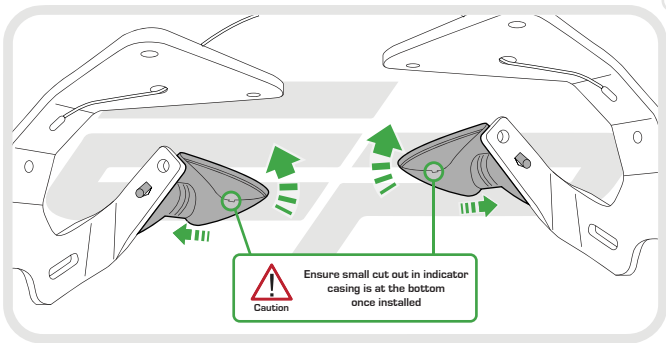

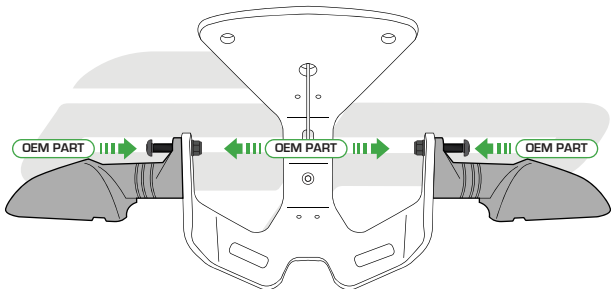

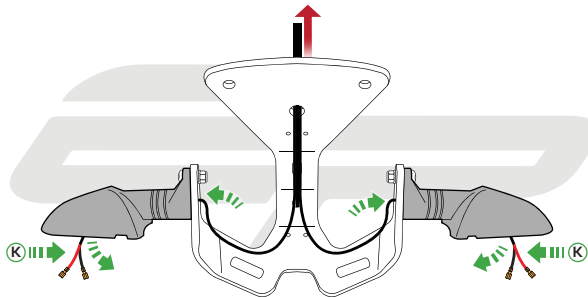

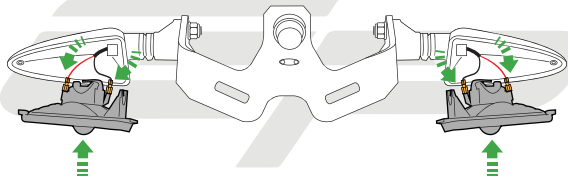

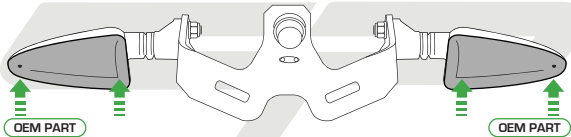

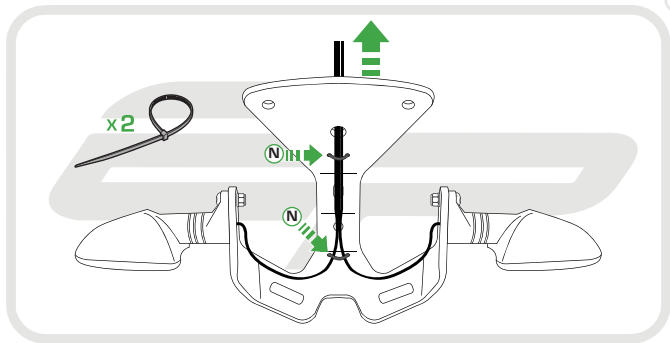

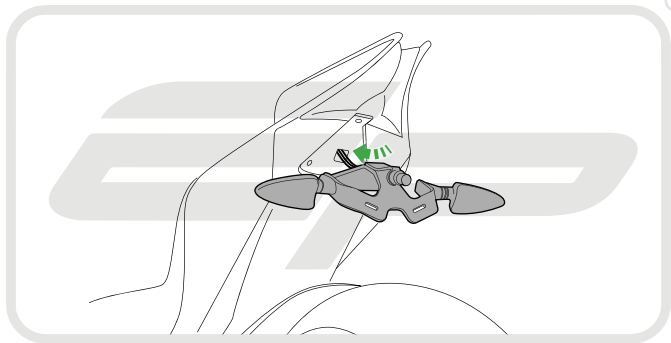

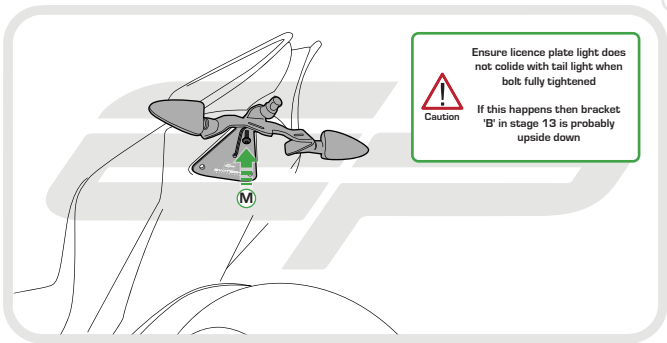

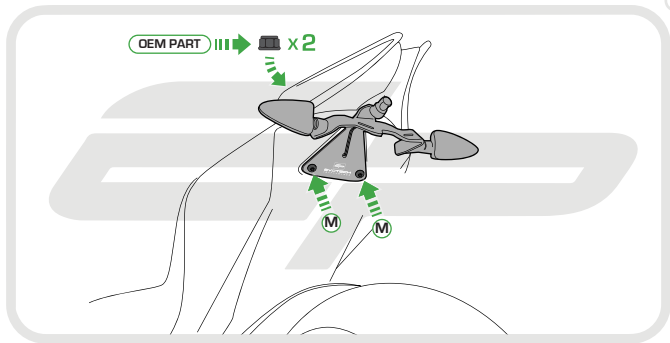

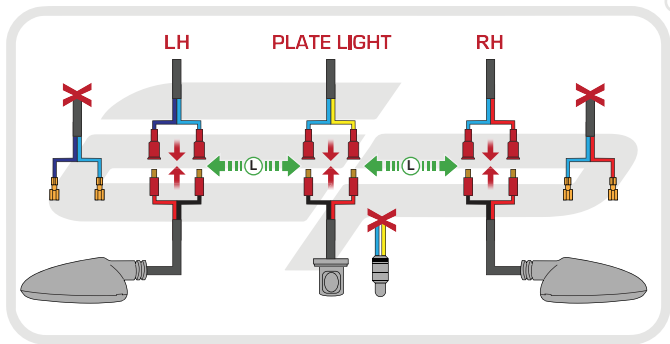



Reverse Stages

3, 2, 1

Reflector Bracket Installation

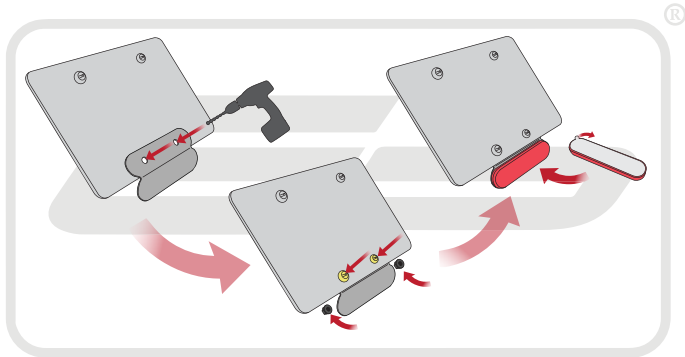

EVOTECH[®]
P E R F O R M A N C E



ESSENTIAL CHECKS



After installation of your tail tidy ensure that the licence plate does not contact the rear tyre when suspension is fully compressed.

Ensure all electrics including indicators, tail light, brake light and licence plate light lights are working correctly before riding the motorcycle.

It is recommended that periodic inspections are made to ensure that all fixings are fully tightend.