

REV	CON NO	DESCRIPTION	SKA	DATE
10		NEW RELEASE	JACKZENG	2018/11/22

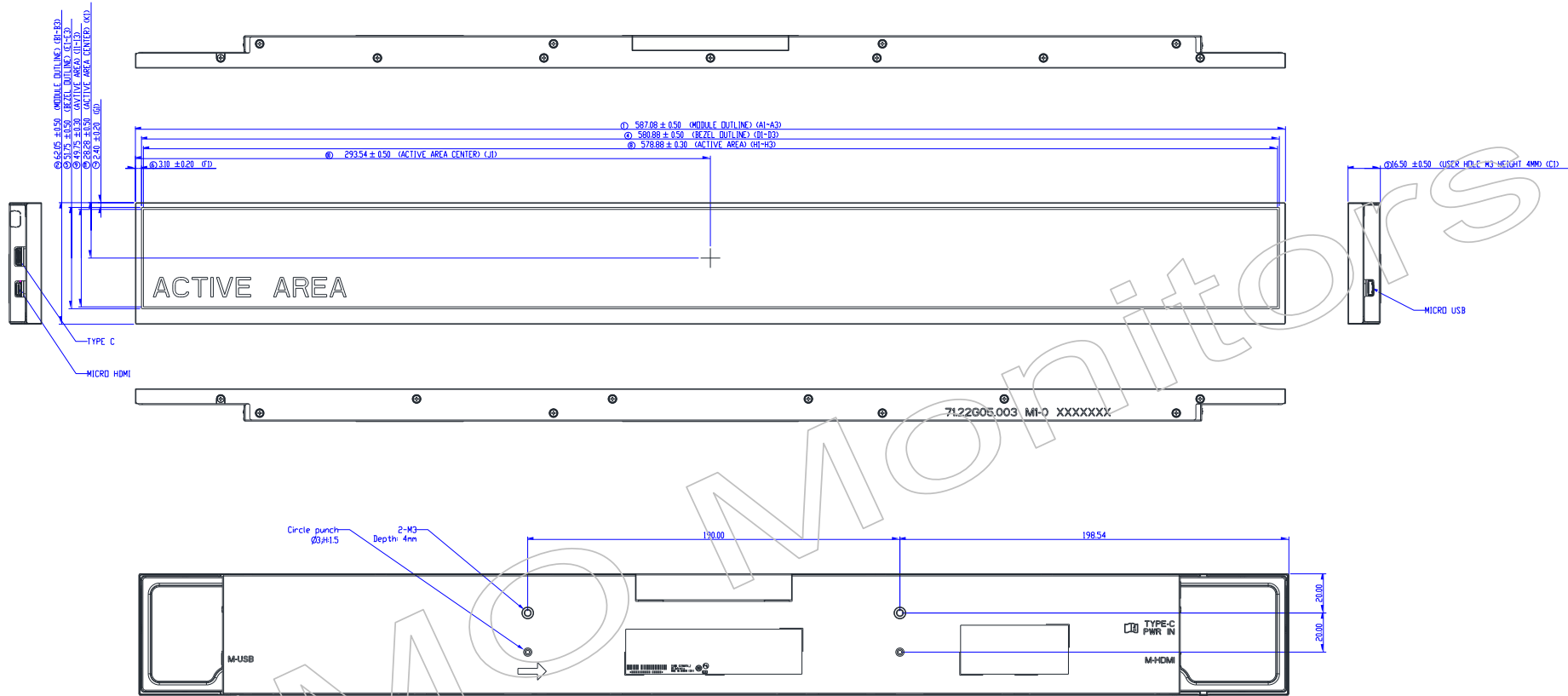

NOTES:

1. PRELIMINARY DRAWING FOR REFERENCE ONLY.
2. THE DIMENSION EXCLUDES DEFORMATION.
3. TOLERANCE WITHOUT SPECIFIED TO $\pm 1\text{mm}$.
4. TORQUE OF M3 USER HOLE SHOULD BE WITHIN 8 KGF-CM AND RE-SCREW 10 TIMES.
5. MODULE THICKNESS SHOULD BE 17.00mm MAX.
6. USER HOLE SCREW PENETRATION ARE 4.0mm MAX.
7. CHECK CODES ARE 1~11.

REV	SCALE	WEIGHT	FILE	GENERAL RELEASE	3rd Angle	ORIGINA	REVIS
10	1:100					MSE-23016	

LEVEL	GENERAL	DESCRIPTION	MATERIAL	AS NOTE	REVISION	DATE
1	1	LEVEL				
2	1	LEVEL				
3	1	LEVEL				
4	1	LEVEL				
5	1	LEVEL				
6	1	LEVEL				
7	1	LEVEL				
8	1	LEVEL				
9	1	LEVEL				
10	1	LEVEL				

