

THERMAL LINE PRINTER

TM-T60/T60P

TM-T80/T80P

Operator's Manual

All rights reserved. No part of this publication may be reproduced, stored in a retrieval system, or transmitted in any form or by any means, mechanical, photocopying, recording, or otherwise, without the prior written permission of Seiko Epson Corporation. No patent liability is assumed with respect to the use of the information contained herein. While every precaution has been taken in the preparation of this book, Seiko Epson Corporation assumes no responsibility for errors or omissions. Neither is any liability assumed for damages resulting from the use of the information contained herein.

Neither Seiko Epson Corporation nor its affiliates shall be liable to the purchaser of this product or third parties for damages, losses, costs, or expenses incurred by purchaser or third parties as a result of; accident, misuse, or abuse of this product or modifications, repairs, or alterations to this product, or (excluding the U . S .) failure to strictly comply with Seiko Epson Corporation's operating and maintenance instructions.

Seiko Epson Corporation shall not be liable, against any damages or problems arising from the use of any options or any consumable products other than those designated as Original Epson Products or Epson Approved Products by Seiko Epson Corporation.

Epson and ESC/POS™ are registered trademarks of Seiko Epson Corporation.

NOTICE:

The contents of this manual are subject to change without notice.

Copyright © 1993 by Seiko Epson Corporation, Nagano, Japan

FCC-CLASS A

FCC COMPLIANCE STATEMENT FOR AMERICAN USERS

This equipment has been tested and found to comply with the limits for a Class A digital device, pursuant to Part 15 of the FCC Rules. These limits are designed to provide reasonable protection against harmful interference when the equipment is operated in a commercial environment.

This equipment generates, uses, and can radiate radio frequency energy and, if not installed and used in accordance with the instruction manual, may cause harmful interference to radio communications. Operation of this equipment in a residential area is likely to cause harmful interference in which case the user will be required to correct the interference at his own expense.

WARNING

The connection of a non-shielded printer interface cable to this printer will invalidate the FCC Certification of this device and may cause interference levels which exceed the limits established by the FCC for this equipment. You are cautioned that changes or modifications not expressly approved by the party responsible for compliance could void your authority to operate the equipment.

FOR CANADIAN USERS

This digital apparatus does not exceed the Class A limits for radio noise emissions from digital apparatus as set out in the radio interference regulations of the Canadian Department of Communications.

Le présent appareil numérique n'émet pas de bruits radioélectriques dépassant les limites applicables aux appareils numériques de Classe A prescrites dans le règlement sur le brouillage radioélectriques édicte par le Ministère des Communications du Canada.

INTRODUCTION

The TM-T60/T60P and the TM-T80/T80P are a one-station printer for ECR and POS use which can be used for printing the results of scaling or measuring.

The main features are as follows:

- . Light and ultracompact
- . High-speed printing
- . low-noise thermal printing
- . High reliability due to a low number of moving parts
- . Maintenance such as head cleaning performed easily
- . Command protocol based on ESC/POS™, a widely used standard
- . Four-way routing of the interface cable, drawer control cable, and power cable on either side, underneath, or out the back of the case
- . Easy access to the power switch on the front of the printer body; access to both sides and the back not necessary
- . Bar code printing possible using a bar code command
- . 90° character rotation possible
- . Repeated operation and copy printing possible through macro definition
- . Drawer control possible using the drawer-kick interface

Interface		Paper Width
TM-T60	Serial	60mm
TM-T60P	Parallel	
TM-T80	Serial	80mm
TM-T80P	Parallel	

Please be sure to read the instructions in this manual carefully before using your new Epson printer.

The TM-T60 and the TM-T80 have a serial interface connector and the TM-T60P and TM-T80P have a parallel interface one.

Except for the **different** roll width accommodated by the two printers, the functions provided by the TM-T60/T60P and the TM-T80/T80P are the same. Most of the illustrations used in this operation manual show the TM-T60/T60P.

About this manual

I . SETTING UP

- * **Chapter 1** contains information on unpacking the printer, choosing the place for the printer, and names and functions of parts.
- * **Chapter 2** and **Chapter 3** contain information on connecting and setting up the printer.
- * **Chapter 4** contains information on testing the printer.

II . REFERENCE1

- * **Chapter 5** contains information on using the printer.
- * **Chapter 6** contains information on software control including printer command descriptions.

APPENDIX

Appendixes contain information on general specifications, character code tables and a list of commands.

CONTENTS

I . SETTING UP

Chapter 1 Unpacking the Printer	2
1 - 1 Checking the Contents of the Box	2
1 - 2 Choosing a Place for the Printer	3
I-3 Removing the Protective Material	3
1 - 4 Names and Functions of Parts	4
Chapter 2 Before Setting Up	6
2- 1 Connecting the Power Supply to the Printer	6
2 - 2 Connecting the Host Computer to the Printer	7
Chapter 3 Installing the Parts	9
3 - 1 Installing the Roll Paper	9
3-2 Adjusting the Paper-End Detector	12
3 -3 Setting the DIP Switches	14
Chapter 4 The Self Test	17
4 - 1 The Open-Cover Detector	17
4 - 2 Checking Operation with the Self Test	18

II. REFERENCE1

Chapter 5 Cautions while Using the Printer	20
5 - 1 Panel Switches and Commands	20
5 - 2 Printable Area	21
5 - 3 Miscellaneous Notes	22
5-4 Error Correction	25
5-5 Cleaning the Head	27
Chapter 6 Software Control	28
6 - 1 Printer Control	28
6 - 2 Command Descriptions	29
6-3 Commands	30
6 -4 Program Descriptions	52
APPENDIX	59
APPENDIX A General Specifications	59
APPENDIX B Connectors	63
APPENDIX C Interfaces	66
APPENDIX D Notes on Using the Drawer kick-out Connector -----	71
APPENDIX E Character Code Tables	74
APPENDIX F Command Summary	77

I. SETTING UP

Chapter 1 Unpacking the Printer

1 - 1 Checking the Contents of the Box

■ Checking the parts

Remove the printer and other parts from the box.

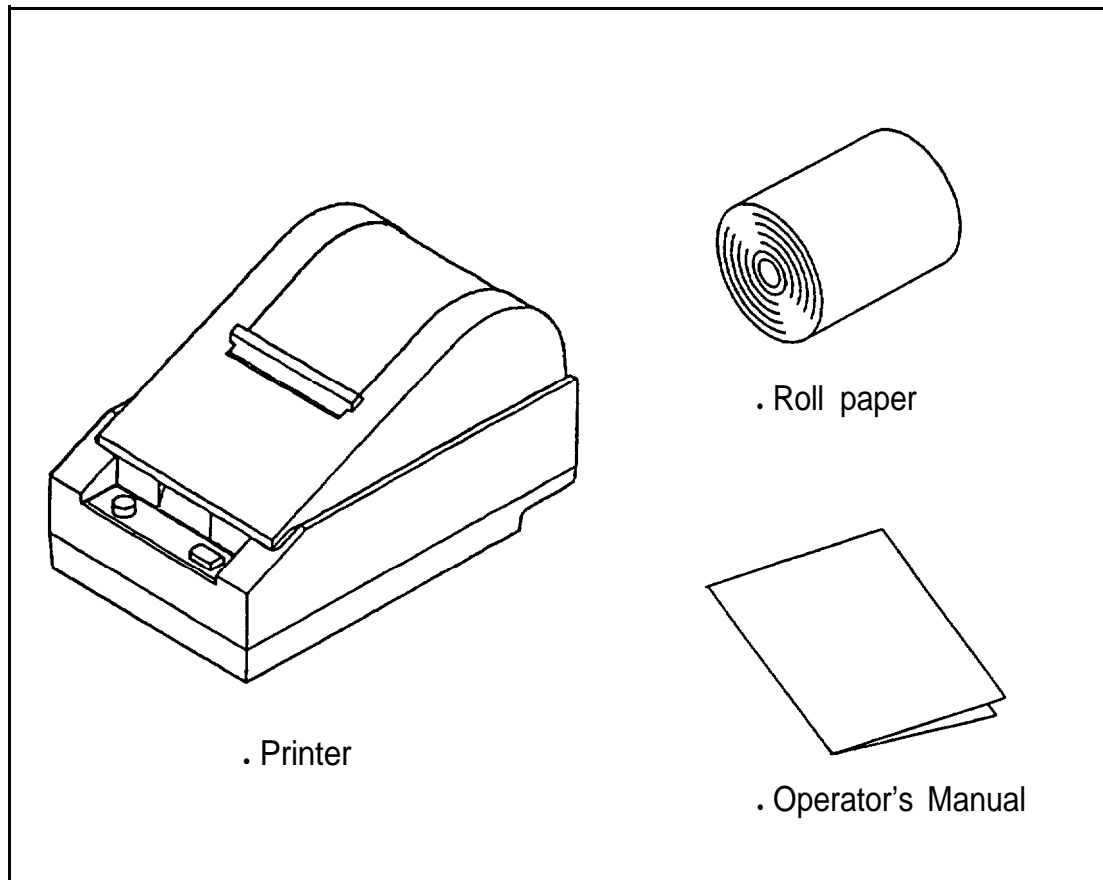

Make sure no parts are missing or damaged.

If you find any damaged or missing parts, please contact your dealer for assistance.

H Maintenance

Keep the packing case and packing materials in case you ever need to transport or store your printer.

■ Optional parts

Power supply (PS-130)) Power supply DC cable (1.5m)

1 - 2 Choosing a Place for the Printer

- Avoid locations that are subject to direct sunlight or excessive heat (near heaters).
- Avoid using or storing the printer in places subject to excessive temperatures or moisture.
- Do not use or store the printer in a dusty or dirty location.
- When setting up the printer, choose a stable, horizontal location. Intense vibration or shock may damage the printer.
- Ensure the printer has enough space to be used easily.

1-3 Removing the Protective Material

An orange plastic spacer is put into the printing mechanism section to protect the printer from damage during transportation. Before you turn on the printer, be sure to remove the spacer according to the following steps.

1. Open the printer cover.
2. Raise the head-open lever to remove the spacer.
3. Store it in the hollow space. Re-insert the spacer when transporting.
4. Lower the head-open lever.

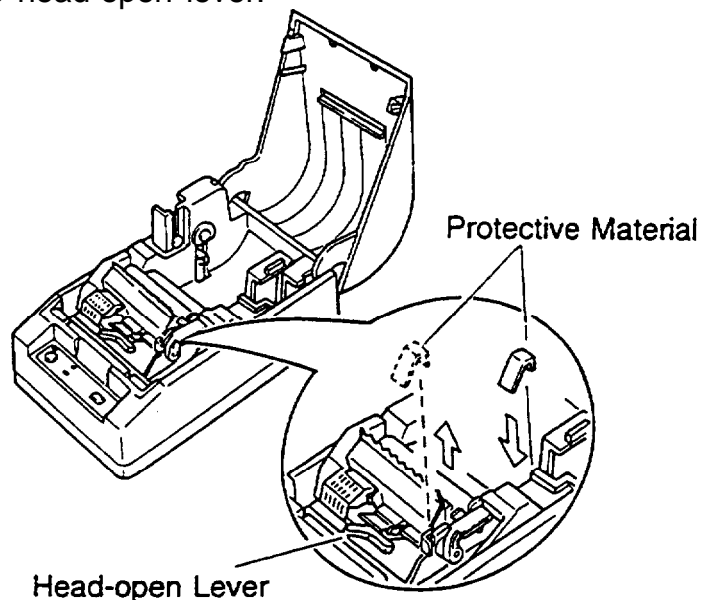

1 - 4 Names and Functions of Parts

■ Part names

- ① Printer cover
- ② Operation panel
- ③ Power connector
- ④ Interface connector
- ⑤ Drawer-kick connector
- ⑥ DIP switches (*1)

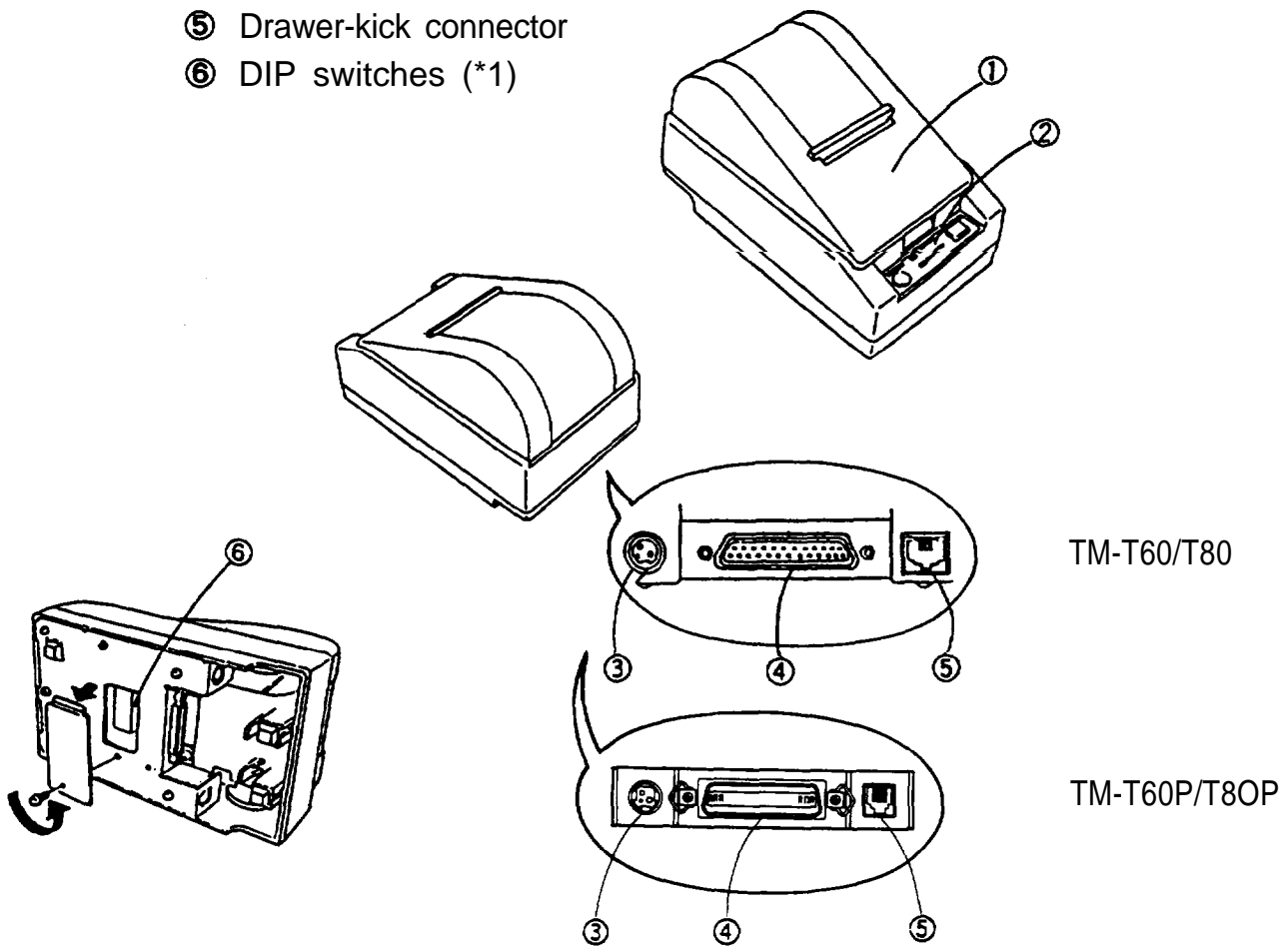

* 1: The DIP switches are located behind the small cover on the bottom of the printer.

■ Operation panel

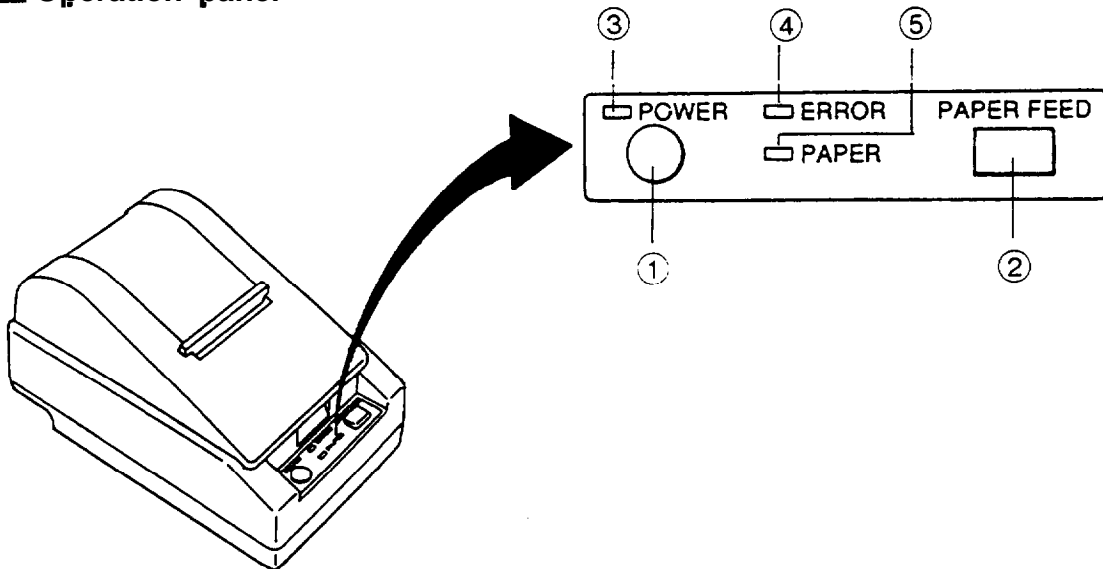

Panel switches

① P O W E R

Press the POWER button to turn the printer ON and OFF. When the button is pushed down, the power is on. When pressed again, the button returns to its original position, turning the power off.

- Do not turn the power off during printing.

② P A P E R F E E D

Press the PAPER FEED button to feed roll paper.

- You cannot feed paper when the printer cover is open.

Panel lights (LED)

③ P O W E R (green)

The POWER light is on when power is turned on.

④ E R R O R (red)

The ERROR light is on when the printer cover is not closed completely, or when the paper roll is near the end. The light blinks during an error condition, or when waiting for data during macro execution.

⑤ P A P E R (red)

The PAPER light is on when roll paper is not loaded, or when the paper roll is near the end.

Chapter 2 Before Setting Up

2- 1 Connecting the Power Supply to the Printer

■ Plugging in AC adapter

The printer must be connected to an external power supply.

Be sure to use a power cable that matches the specifications of both the printer and the power supply unit.

CAUTIONS:

- . Before connecting the printer to the power supply, make sure that the voltage (24 VDC) and power specifications match the printer's requirements.
- . Using an incorrect power supply can cause serious damage to the printer.

Connect the power unit according to the following procedure.

- ① Make sure the printer and the power unit are turned off.
- ② Plug the power cable's connector into the printer's power connector with the arrow mark facing downward.
- ③ Plug the power cord into the outlet, and turn on the power unit.

TM-T60/T80

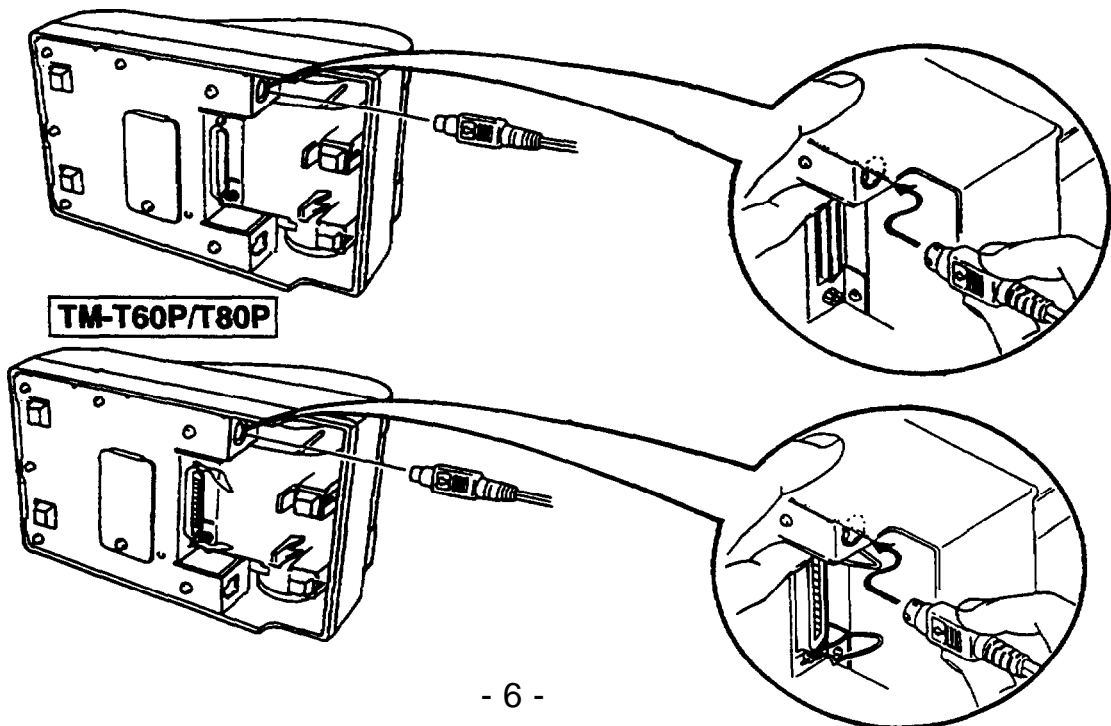

2-2 Connecting the Host Computer to the Printer

■ Connecting the interface cable

Connect the printer to a host ECR (host computer) using an interface cable matching the specifications of the printer and the host ECR (host computer).

TM-T60/T80

Connect the interface cable according to the following procedure.

- ① Turn off the printer, power unit, and host computer.
- ② Plug the interface cable connector into the interface connector on the printer; then insert a screwdriver between the rear rubber feet and fasten the screws on both sides of the connector.
- ③ Plug the drawer-kick cable connector into the drawer-kick connector on the printer (if this connector is covered, you cannot attach a drawer-kick cable to your printer).
 - Remove the drawer-kick cable by pressing in on the connector's clip and pulling out.

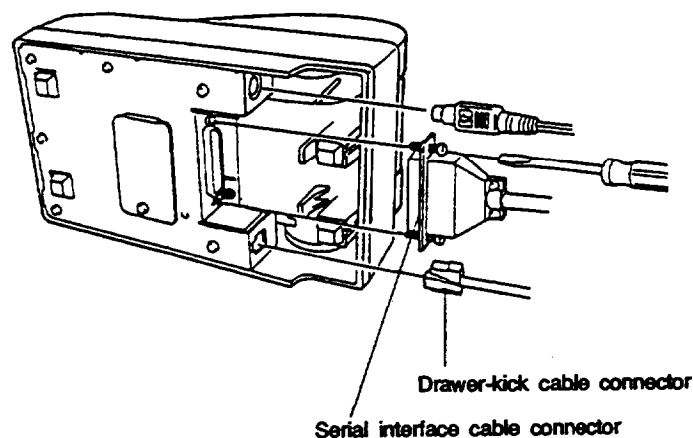

TM-T60P/T80P

Connect the interface cable according to the following **procedure**.

- ① Turn off the printer, power unit, and host computer.
- ② Plug the interface cable connector into the interface connector on the printer.
- ③ Squeeze the wire clips together until they lock in place on both sides of the connector.
- ④ Attach the ground wire to the ground connector on the right side of the interface connector.
- ⑤ Plug the drawer-kick cable connector into the drawer-kick connector on the printer (if this connector is covered, you cannot attach a drawer-kick cable to your printer).

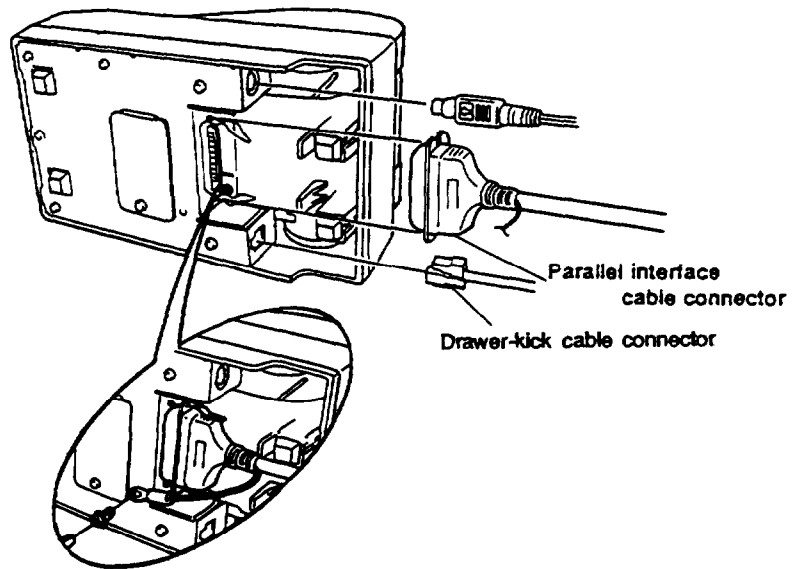

Chapter 3 Installing the Parts

3-1 Installing the Roll Paper

■ Installing the roll paper

Be sure to use roll paper that matches the printers specifications.

- ① Using scissors, cut the leading edge of the roll paper perpendicular to the paper feed direction.
- ② Open the printer cover and raise the release-lever toward you.

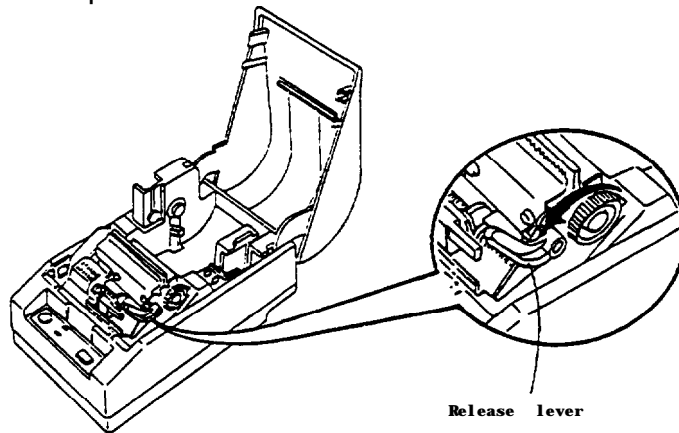

- ③ Load the roll paper while lightly pressing the right roll paper holder outward. Release the holder after fitting the paper core onto the holder. Make sure the roll paper turns freely. When loading roll paper, make sure to insert so that it rotates in the correct direction.

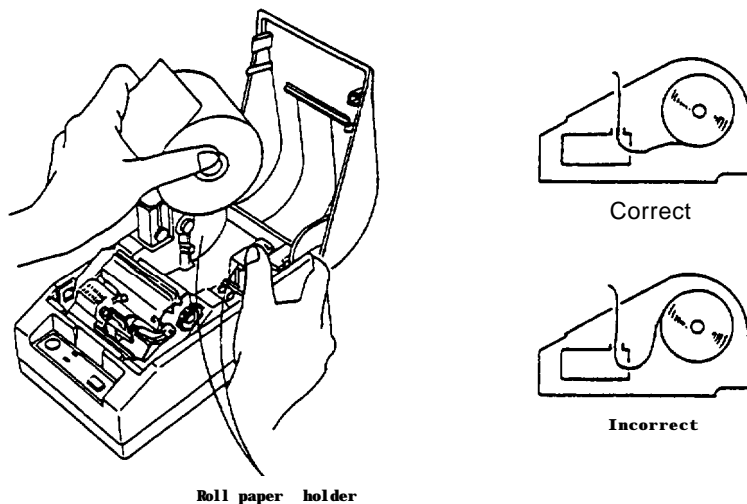

Chapter 3 Installing the Parts

3-1 Installing the Roll Paper

■ Installing the roll paper

Be sure to use roll paper that matches the printer's specifications.

- ① Using scissors, cut the leading edge of the roll paper perpendicular to the paper feed direction.
- ② Open the printer cover and raise the release-lever toward you.

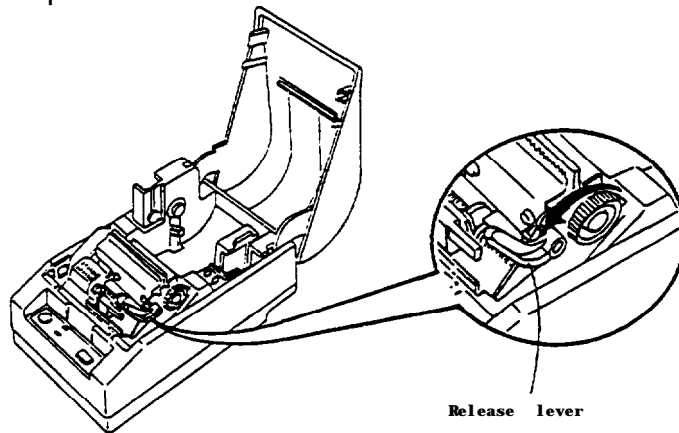

- ③ Load the roll paper while lightly pressing the right roll paper holder outward. Release the holder after fitting the paper core onto the holder. Make sure the roll paper turns freely.
- * When loading roll paper, make sure to insert so that it rotates in the correct direction.

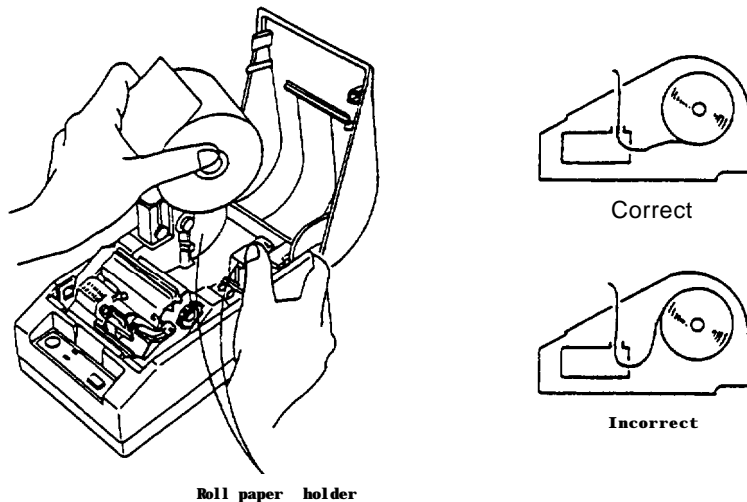

Insert the edge of the roll paper into the paper slot and turn the paper-feed knob in the direction of the arrow to feed the paper 5 cm beyond the tear-off edge.

- Don't turn the paper-feed knob when the release lever is down.

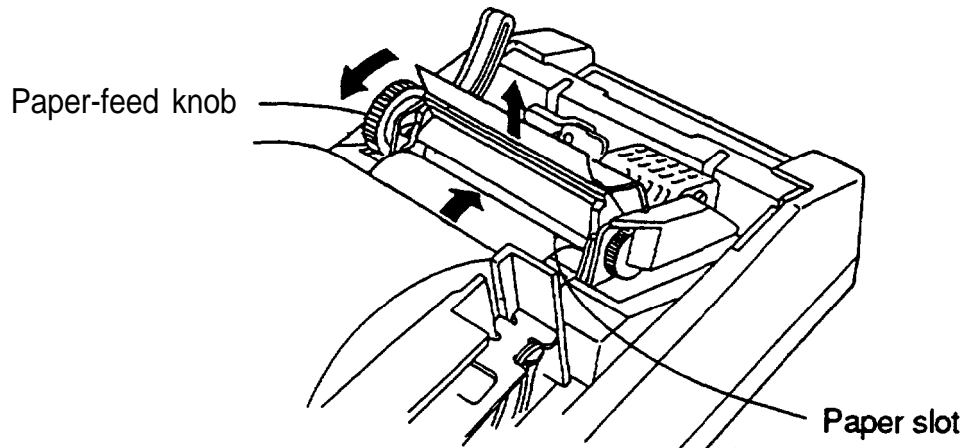

- ⑤ Raise the head-open lever, unroll the paper a little and pull lightly from the roll paper side to eliminate twist or misalignment. Retighten the roll paper to remove any slack. Both edges of the paper should be aligned parallel to the paper roll.
- ⑥ Push down the release lever and then the head-open lever. Tear off any extra paper at the tear-off edge by pulling the paper toward you.

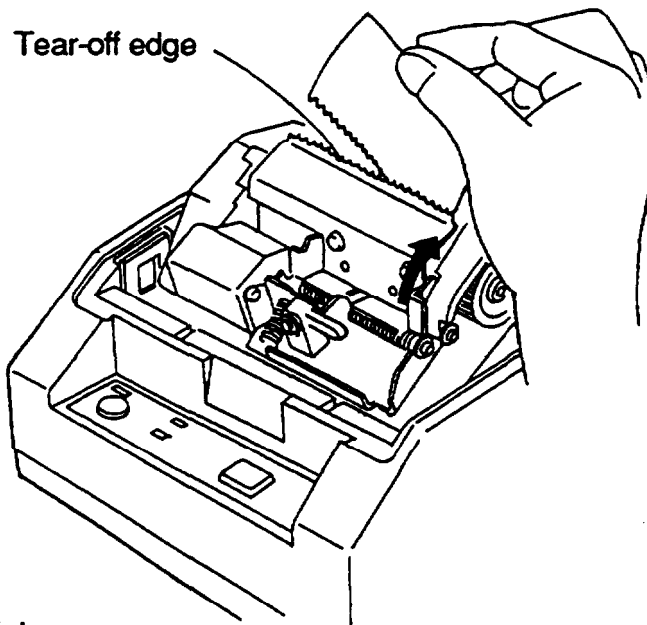

- ⑦ Close the **printer cover**.

■ Removing jammed paper

Removing jammed paper according to the following steps.

① Open the printer cover and raise the head-open lever.

CAUTION:

* The print head is very hot immediately after printing.

Always remove jammed paper after the print head has cooled.

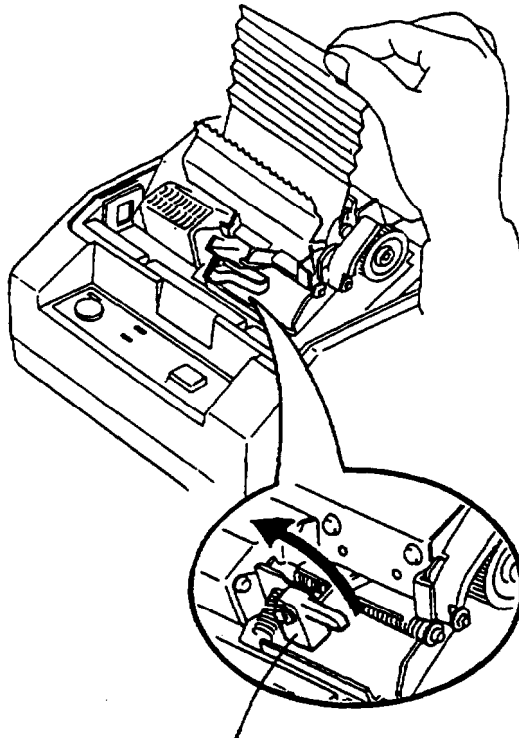

Head-open lever

② Remove any jammed paper.

CAUTION:

. Never touch the print head.

③ Push the head-open lever down. Reload roll paper and close the printer cover. See 3-1 ①~⑥.

3 -2 Adjusting the Paper-End Detector

■ The paper-end detector

The paper-end detector senses when the paper is nearing its end and turns on the PAPER lamp.

The paper-end detector can be adjusted according the thickness of the Paper.

■ How to adjust the paper-end detector

Roll paper may differ in spool size, so it may be necessary to adjust the paper-end detector.

- ① Use the specified paper roll with a **cure** inside diameter (d1) of 12mm and an outside diameter (d2) of 18 mm.
- ② The thickness of the spool can **vary**; use the table to determine the paper-end detector adjustment.

Table 3-I. Adjustment Values of the Paper-end Detector

Adjustment Value	Dimension of T (mm)
#1	Approx. 0
#2	Approx. 2
#3	Approx. 4
#4	Approx. 6
#5	Approx. 8
#6	Approx. 10

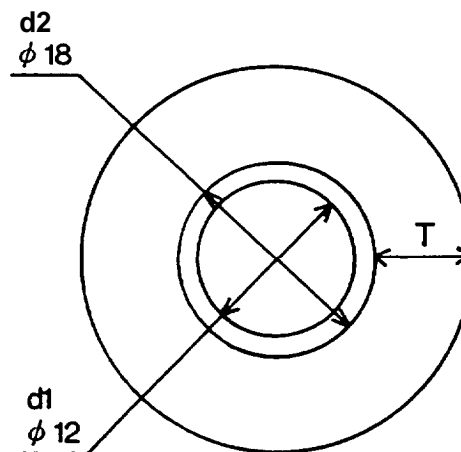

- ③ Loosen the adjusting screw that holds the paper-end detector. Then set the top of the positioning plate to the appropriate adjustment position, and tighten the adjusting screw.

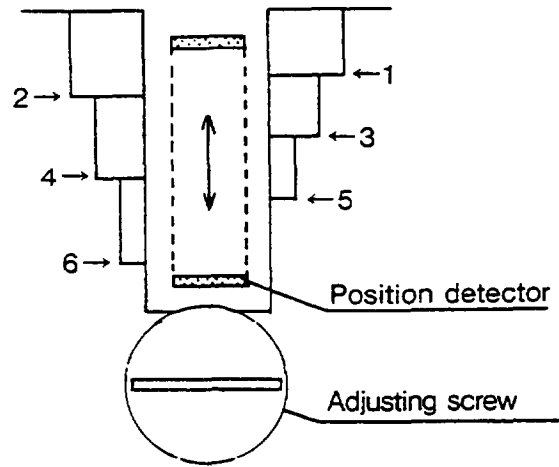

NOTES:

- 1 . The T dimensions corresponding to the adjustment values in the table are calculated from standard measurements; some variations in the actual mechanism.
2. After adjusting, ensure that the detector operates smoothly.

3 -3 Setting the DIP Switches

■ Locating the DIP switches

On the underside of your printer are a number of DIP switches that can be set to perform a number of different functions.

- You can change the function of your printer by turning DIP switches on or off.
- Current DIP-switch settings are printed out during the self test.
- The switches numbered from left to right are SW1-1 through SW1-10 (TM-T6O/T8O) or SW1-1 through SW1-5 (TM-T6O/T8OP).
- Each switch functions as described in the lists on the following page.

■ Setting the DIP switches

Follow these steps when changing DIP-switch settings.

Turn the printer power supply off.

Remove the small cover on the printer's bottom to expose the DIP switches.

Flip the DIP switches using tweezers or other narrow-ended tool.

Switches in the up position are ON; those in the down position are OFF.

TM-T6O/T8O

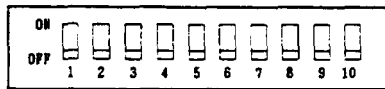

TM-T6()p/T8oP

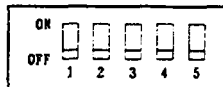

NOTE:

- Changes made with the power on have no effect until the power supply is turned off and then on again.

■ **TM-T60/T60 DIP-Switch Functions**

Table 3-2 DIP-Switch Functions (On the bottom of the case)

DIP SW1	ON	OFF
SW- 1	Ignores data reception errors	Prints “?” for data reception errors
SW-2	Data buffer 45 bytes	Data buffer 4 Kbytes
SW3	XON/XOFF control	DTR/DSR control
SW-4	Parity	No Parity
SW-5	Even parity	Odd parity
SW-6	Change baud rate (Refer to Table 3-3)	
SW-7		
SW-8	Change print density (Refer to Table 3-4)	
SW-9		
SW-10	Normally OFF	

Table 3-3. Baud Rate Selection

Baud Rate	SW1 - 6	SW1 - 7
1200 bps	ON	ON
4800	OFF	ON
9600	ON	OFF
19200	OFF	OFF

Table 3-4. Print Density Selection

Print Density	SW1 -8	SW1 -9	Level
LIGHT	ON	ON	1
	OFF	OFF	2
DARK	ON	OFF	3
	OFF	ON	4

■ **TM-T60P/T80P DIP-Switch Functions**

Table 3-5. DIP-Switch Functions (On the bottom of the case)

DIP SW1	ON	OFF
SW-1	Auto-feed function is always valid	Depends on $\overline{\text{AUTO FEED XT}}$ signal
SW-2	Data buffer 0 byte	Data buffer 4 Kbytes
SW-3	Character print density (Refer to Table 3-6)	
SW-4		
SW-5	Normally OFF	

Table 3-6. Print Density Selection

Print Density	SW1-3	SW1-4	Level
LIGHT	ON	ON	1
	OFF	OFF	2
DARK	ON	OFF	3
	OFF	ON	4

Chapter 4 The Self Test

4 - 1 The Open-Cover Detector

■ The open-cover detector

This unit has an open-cover detector located inside the printer cover.

- Data is not printed when the printer cover is open.
- Opening the cover sets the printer OFF LINE; data cannot be received when the printer is OFF LINE.
- Paper cannot be fed with the paper-feed switch when the printer cover is open.

■ Returning the printer ON LINE

- Closing the cover sets the printer ON LINE automatically.

CAUTION:

The printer cover cannot be closed unless the head-release lever and the head-open lever are down.

II. REFERENCE

Chapter 5 Cautions while Using the Printer

5 - I Panel Switches and Commands

■ switches

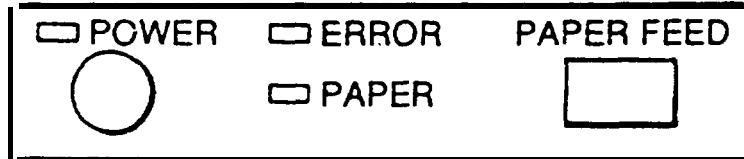

(1) Power switch

Function

Turns the power supply on/off.

Note

- The RAM is initialized after turning off the circuit power supply.
- Don't touch the power supply switch during printing.

(2) Paper-Feed switch

Function

If this switch is pressed, paper is fed one line based on the currently specified line spacing. If this switch is held for 200 ms or more, paper is fed as long as the switch is pressed, and stops when the switch is released. If line spacing is set to 0, paper is fed while the switch is pressed.

- The defined macro is executed when the switch is pressed during the macro executing command standby state.
- Paper is fed by operating this switch, except during printing, an error state, and the macro executing command standby state.
- Paper feeding is performed even during the paper near-end state.

Note

- Paper cannot be fed when the printer cover is open.
- * The paper-feed switch can be enabled or disabled with the ESC c5 command. When this switch is disabled, you cannot feed paper with the switch.

5-2 Printable Area

Printable Area

The print area must be within the range indicated below.

(1) TM-T60/T60P

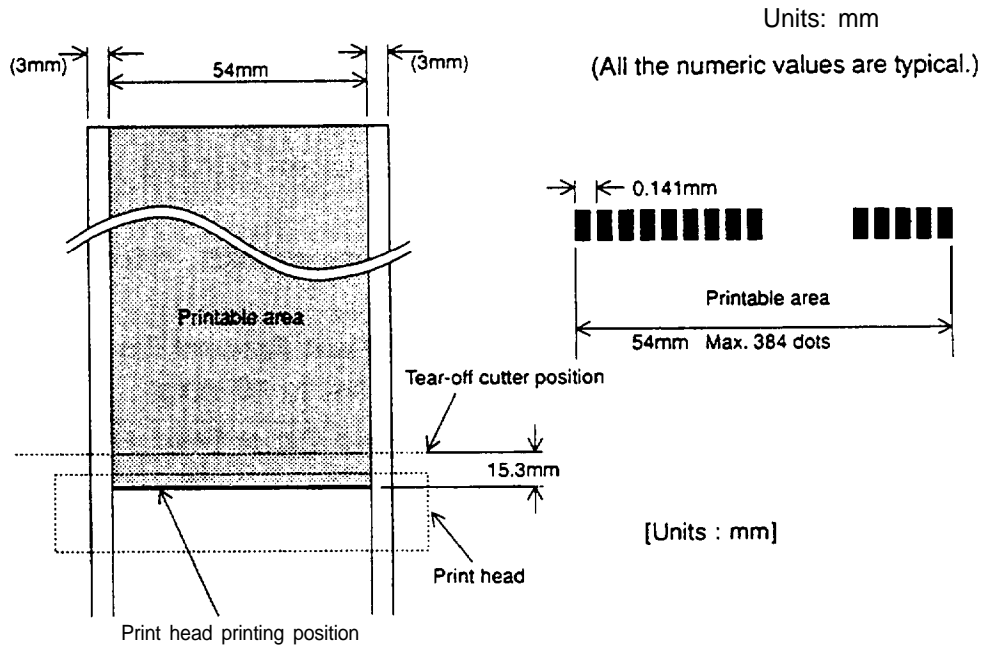

(2) TM-T80/T80P

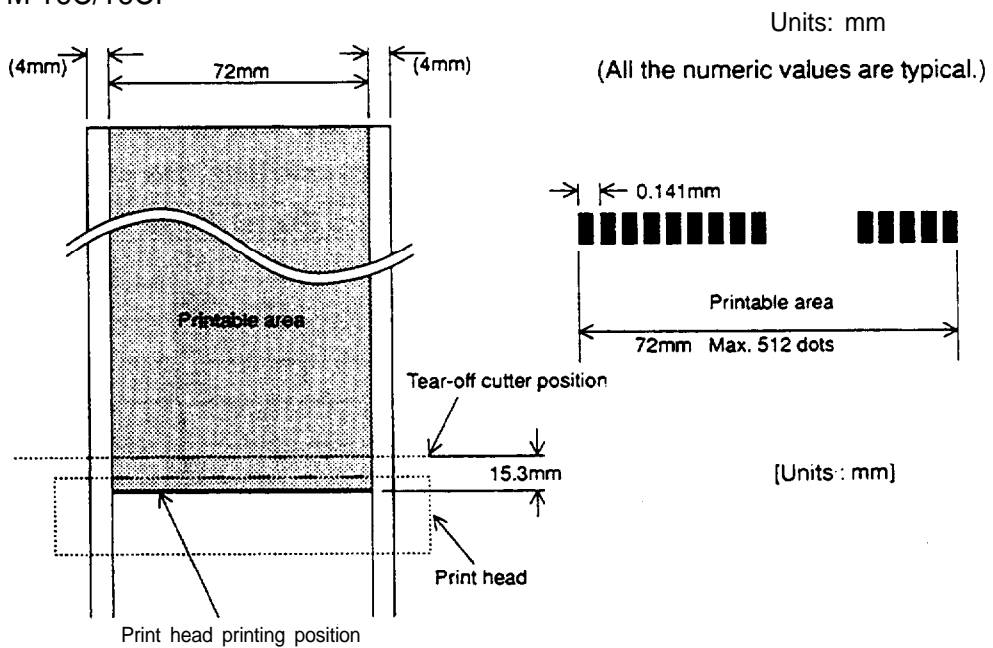

5 -3 Miscellaneous Notes

■ Notes on printing and paper feeding

(1) Because the TM-T60/T8OP and TM-T80/T8OP are a line printer, they automatically feed paper after printing the data.

When the line spacing is set to a small value, the paper may be fed more than the set amount to print all the data.

For example, when the line spacing is set to 10 dots (10/180 inch), the printer normally feeds just 10 dots for a carriage return; however, the printer feeds the paper 24 dots when printing normal Font A characters. (Refer to Table 5-1)

When all the characters on one line are rotated, refer to Table 5-2 for paper feeding.

Table 51. Required Paper Feed Amount Dots
(When the line spacing is set to 10 dots)

		Required Paper Feed Amount (dots)
Font A	Normal characters	24
	Doubleheight	48
	Double-width	24
	Quadruple	48
Font B	Normal characters	17
	Double-height	34
		17
		34
		24

Table 5-2. Required Paper Feed Amount Dots
(When all the characters on one line are rotated)

		Required Paper Feed Amount (dots)
Font A	Normal characters	12
	Double-height	24
	Double-width	12
	Quadruple	24
Font B	Normal characters	9
	Double-height	18
	Double-width	9
	Quadruple	18

- (2) When the printer goes to the standby (data-waiting) state during printing, the printer stops printing and feeding paper temporarily.
When the printer restarts, the paper may shift 1 to 3 dots at the start of printing. Graphics printing is particularly affected by this.

■ **Notes on the power supply**

- Turn the external power supply on after connecting it to the power supply connector.
- Be sure you don't connect the external power supply with the wrong polarity. If it is connected incorrectly, the internal circuit fuse may blow or the external power supply may be damaged.
- The power supply voltage should be 24 VDC $\pm 7\%$.
The voltage fluctuation between no-load and printing should be $\pm 2\%$ or less. If the power supply voltage fluctuates more than this, print quality will be poor.

■ **Notes on handling the printer mechanism**

- Don't turn the paper-feed knob while the print head is down.
- Don't pull paper out (forward/backward directions) while the print head is down.
- The thermal elements of the head and driver IC are easily damaged; avoid touching them with anything made of metal.
- The areas around the print head and motor surface are very hot during and just after printing; don't touch directly with your fingers.
- Operate the head-open lever only when necessary.
- Don't touch the surface of the head's thermal elements directly with your fingers. (Dust and dirt can stick to the surface and affect the thermal elements.)
- Thermal paper containing Na⁺, K⁺, and Cl⁻ ions will affect the head's thermal elements. Be sure to use only the paper specified.
- Label paper cannot be used.

■ **Notes on paper cutting**

Roll paper may be pulled out slightly when paper is manually cut. Dots may have a squeezed appearance in the vertical direction after cutting.

To prevent this, feed paper for 12 steps (6 dots) or more before printing.

■ Handling thermal paper

(1) Notes on using thermal paper

Chemicals and oil that come into contact with the thermal paper may cause paper discoloration, and can also cause the 'printing to fade.

Therefore, pay attention to the following:

- a) Use water-based paste, starch paste, polyvinyl paste, or MC paste when gluing thermal paper.
- b) Volatile organic solvents such as alcohol, ester, and ketone can cause discoloration.
- c) Some adhesive tapes may cause discoloration, and may also cause the printed image to fade.
- d) If thermal paper touches anything that contains phthalic acid ester plasticizer for a long period, it can reduce the image formation ability of the paper and can cause the printed image to fade. When storing thermal paper in a card case or sample notebook, be sure to use only products made from polyethylene, polypropylene, or polyester.
- e) If thermal paper touches copy paper immediately after copying, the printed surface may discolor.
- f) Thermal paper must not be stored with the printed surfaces touching each other because the printing may be transferred between the surfaces.
- g) If the surface of thermal paper is scratched with a nail or other hard metal object, it may discolor.

(2) Notes on thermal paper storage

Color development begins at 70°C, so the following precautions should be taken.

- a) Store paper away from high temperature and humidity. Don't store thermal paper near a heater or in direct sunlight.
- b) Avoid direct light.
If exposed to direct light for a prolonged period, paper color may change or printed images may fade.

5 - 4 Error Correction

■ ERROR LED (red)

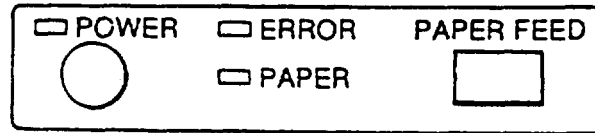

Lights: On when the printer cover is not closed completely, or when the paper roll is near the end.

Blinking: Blinks during the error states shown in Table 5-3.

Blinks during the print-waiting state (macro executing command) shown in Table 5-4.

Table 5-3. Error Display

Error	ON/OFF Timing Pattern	Recovery
RAM check error		Impossible to recover
Transistor error		Impossible to recover
Power supply voltage, high voltage error		Impossible to recover (Power supply should be inspected.)
Power supply voltage, low voltage error		Impossible to recover (Power supply should be inspected.)

Table 5-3. Error Display (Continued)

Error	ON/OFF Timing Pattern	Recovery
Print head thermistor error		Impossible to recover
Internal data processing error		Recovered by turning the power off and on
Print head paper out error		Recovered by closing the cover after inserting paper
Print head overheating error		Recovers automatically when the print head temperature drops back down

Table 54. Macro Executing Command Standby State Display

Error	ON/OFF Timing Pattern	Recovery
Waiting for macro execution		Recovered after executing the macro by pressing the paper-feed switch

The macro executing command can specify the number of executions of a specified definition range. At that time, continuous execution of the macro or execution of the macro with the paper-feed switch is selectable.

When executing the macro with the paper-feed switch, the error LED blinks to indicate the print-waiting state.

5-5 Cleaning the Head

■ Cleaning the head

Cleaning the head according to the following procedure.

CAUTION:

Do not clean the head immediately after printing; the head may be hot.

Open the printer cover and raise the head-open lever.

If roll paper is loaded, remove it from the head area.

Clean the heating element of the head with a cotton swab containing an alcohol solvent (ethanol, methanol, or IPA).

CAUTION:

Never touch the head; oils on your skin can damage the head.

Push the head-open lever down. Reload roll paper and close the printer cover. See 3-1.

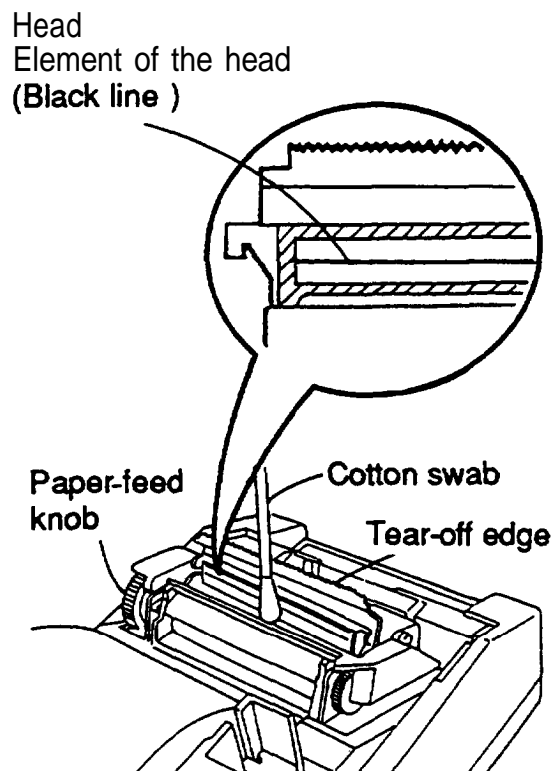

Chapter 6 Software Control

6 - 1 Printer Control

■ Controlling the printer with commands

The printer is controlled by “commands” that can change the size of the characters, and perform other functions.

See APPENDIX E Character Code Tables and APPENDIX F command Summary.

There are two types of commands.

One-byte commands

- **HT** Horizontal tab
- **LF** Print and line feed

Several-byte commands

- **ESC SP** Set character right-side spacing
- **ESC 3n** Set line spacing using minimum units

■ How to use this table

Horizontal by vertical hex

i.e. 4A = J

< >_H denotes hexadecimal

< > denotes decimal numbers

(Refer to APPENDIX E)

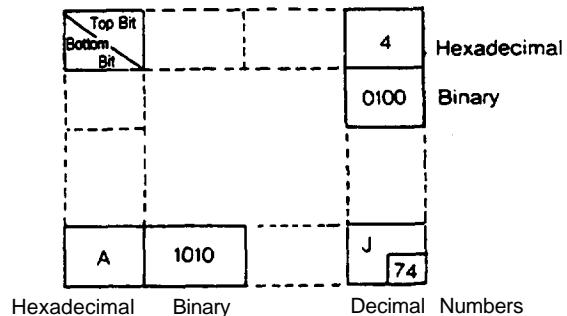

6 - 2 Command Descriptions

■ Command descriptions

- * XXX Command
- * Name The name of the command
- * Format The code sequence
In this description, < >_H denotes hexadecimal numbers, < > denotes decimal numbers and < >_B denotes binary numbers.
[]_k indicates the contents of the [] should be repeated _k times.
- * **Range** The allowable range for the arguments
- * **Description** Description of the command function
- * Notes (Included only when necessary)
- * Default The default values for the commands
- * Reference Related commands
- * **Example** Example of using the commands

6 - 3 Commands

HT

Name	Horizontal tab
Format	< 09 > _H
Description	Moves the print position to the next horizontal tab position. . This command is ignored unless the next horizontal tab position has been set.
Notes	- Horizontal tab positions are set using ESC D. - The default horizontal tab positions are at intervals of 8 characters (9th column, 17th, 25th. . .) for Font A.
Reference	ESC D

LF

Name	Print and line feed
Format	
Description	Prints the data in the print buffer and performs 1 line feed based on the current line spacing. - Sets the print starting position to the beginning of the line.
Reference	ESC 2, ESC 3, 5-3 Miscellaneous Notes

CR

Name	Print and carriage return
Format	
Description	This function is available only for the TM-T60P/T80P Performs the same function as LF when the auto feed function is enabled. If not, this command is ignored. - Sets the print starting position to the beginning of the line.

ESC SP *n*

Name	Set character right-side spacing
Format	< 1B > _H < 20 > _H < <i>n</i> >
Range	0 ≤ <i>n</i> ≤ 32
Description	Sets the character right-side spacing in dot units (1/180-inch units).
Notes	<ul style="list-style-type: none">• The character right-side spacing for double-width mode is twice the set value.
Default	<i>n</i> =0

ESC ! *n*

Name	Set print mode
Format	< 1B > _H < 21 > _H < <i>n</i> >
Range	0 ≤ <i>n</i> ≤ 255
Description	Sets a print mode. <ul style="list-style-type: none">• Each bit of <i>n</i> is used as follows:

Bit	Function	Value	
		0	1
0	Character font	Font A	Font B
1	Undefined		
2	Undefined		
3	Undefined		
4	Double-height	cancel	set
5	Double-width	cancel	set
6	Undefined		
7	Underline		

Notes	<ul style="list-style-type: none">• When both double-height mode and double-width mode are set, quadruple characters are printed.
Default	<i>n</i> = 0

ESC % *n*

Name	Set/cancel user-defined character set
Format	< 1B > _H < 25 > _H < <i>n</i> >

Range	$0 \leq n \leq 255$
Description	<p>Sets or cancels the user-defined character set.</p> <ul style="list-style-type: none"> • Only the lowest bit of n is valid. <p>When $n = \langle \text{*****}1 \rangle_{\text{B}}$, the userdefined character set is set.</p> <p>When $n = \langle \text{*****}0 \rangle_{\text{B}}$, the userdefined character set is canceled (and the internal character set is set).</p>
Default	$n = 0$
Reference	ESC &

ESC & s n m [a[p]sXa]m-n+1

Name	Define user-defined characters
Format	$\langle 1 \text{ B} \rangle_{\text{H}} \langle 2 \text{ 6} \rangle_{\text{H}} \langle s \rangle \langle n \rangle \langle m \rangle [\langle a \rangle \langle p1 \rangle$ $\langle p2 \rangle \dots \langle psXa \rangle] m-n+1$
Range	$s = 3$ $32 \leq n \leq m \leq 126$ $0 \leq a \leq 12$ (Font A) $0 \leq a \leq 9$ (Font B) $0 \leq p1 \dots psXa \leq 255$
Description	<p>Defines user-defined characters for ANK character codes.</p> <ul style="list-style-type: none"> - "s" specifies the number of bytes in the vertical direction. - "n" specifies the beginning ASCII code for the definition and "m" the final code. If only one character is defined, use $n = m$. - The allowable character code range is from ASCII code $\langle 20 \rangle_{\text{H}}$ to $\langle 7E \rangle_{\text{H}}$ and the maximum number of characters is 95. - "a" specifies the number of dots in the horizontal direction. - "p" Is the dot data for the characters. The dot pattern for a dots is in the horizontal direction from the left side. The remaining dot pattern on the right side is space. The amount of data to be defined is sXa. - After userdefined characters are defined once, they are available until another definition is made, until ESC @ is

executed, until GS * is executed, or until the printer is turned off.

Notes

. The user-defined characters and a down-loaded bit image cannot be defined at the same time. If this command is executed, the down-loaded bit image will be cleared.

Default

The same as the internal character set.

Reference

ESC %

Example

- Font A is selected:

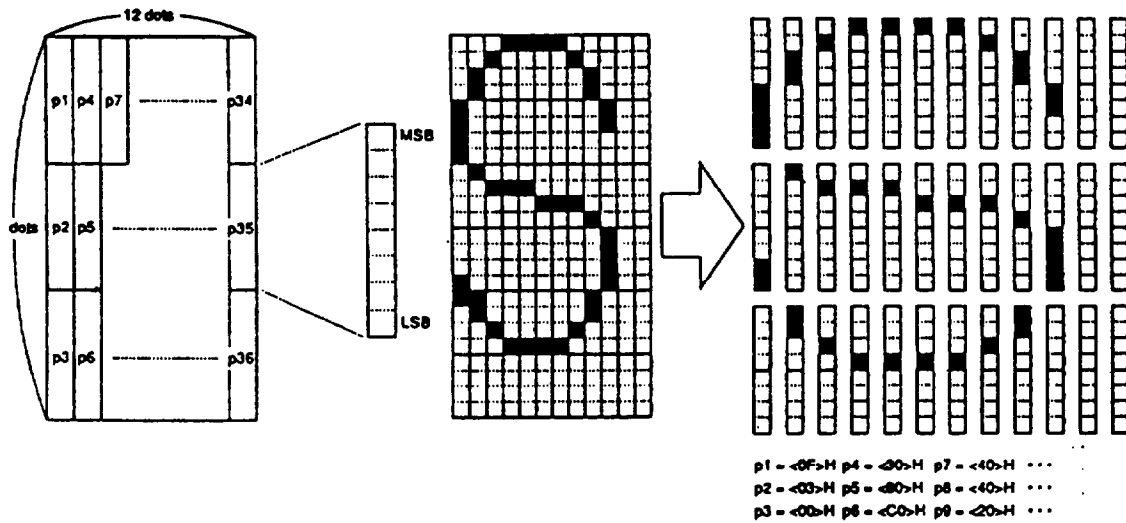

- Font B is selected:

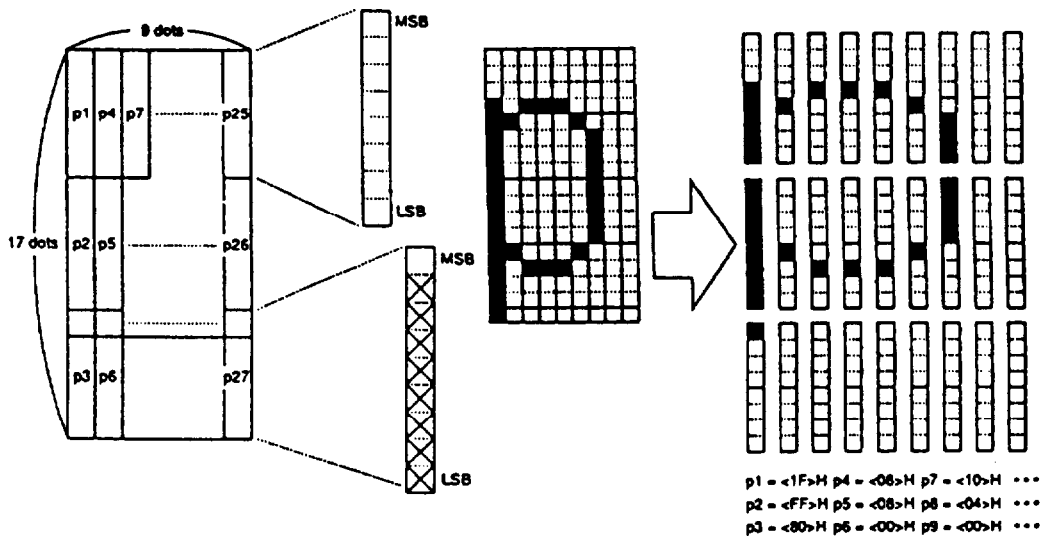

ESC * *m n1 n2 [d]k*

Name	Set bit image mode
Format	< 1B > _H < 2A > _H < <i>m</i> >< <i>n1</i> >< <i>n2</i> >[< <i>d</i> >]k
Range	<p><i>m</i> = 0, 1, 32, 33</p> <p>$0 \leq n1 \leq 255$</p> <p>$0 \leq n2 \leq 3$</p> <p>$0 \leq d \leq 255$</p> <p>$k = n1 + 256 \times n2$ (<i>m</i> = 0, 1)</p> <p>$k = (n1 + 256 \times n2) \times 3$ (<i>m</i> = 32, 33)</p>
Description	<p>Sets the bit image mode using <i>m</i> and the number of dots using <i>n1</i> and <i>n2</i>.</p> <ul style="list-style-type: none"> . Divide the number of dots to be printed by 256. The integer answer is <i>n2</i> and the remainder is <i>n1</i>. Therefore, the number of dots in the horizontal direction is: $n1+256 \times n2$. . If the bit image data input exceeds the number of dots to be printed on a line, the excess data is ignored. . “<i>d</i>” indicates the bit image data. Set a corresponding bit to 1 to print a dot, otherwise set it to 0. - The bit image modes selectable by <i>m</i> are as follows:

<i>m</i>	Mode	Vertical Direction		Horizontal Direction	
		Number of Dots	Dot Density	Dot Density	Maximum Number of Dots
0	8-dot single-density	8	60 DPI	90 DPI	192
1	8-dot double-density	8	60 DPI	180 DPI	384
32	24-dot single-density	24	180 DPI	90 DPI	192
33	24-dot double-density	24	180 DPI	180 DPI	384

Notes	<ul style="list-style-type: none"> . If <i>m</i> is out of range, <i>n1</i> and the data following will be processed as normal data. . After printing a bit image, the printer returns to the normal data processing mode.
--------------	--

- The relationship between the image data and dots to be printed is as follows:
- 8-dot bit image

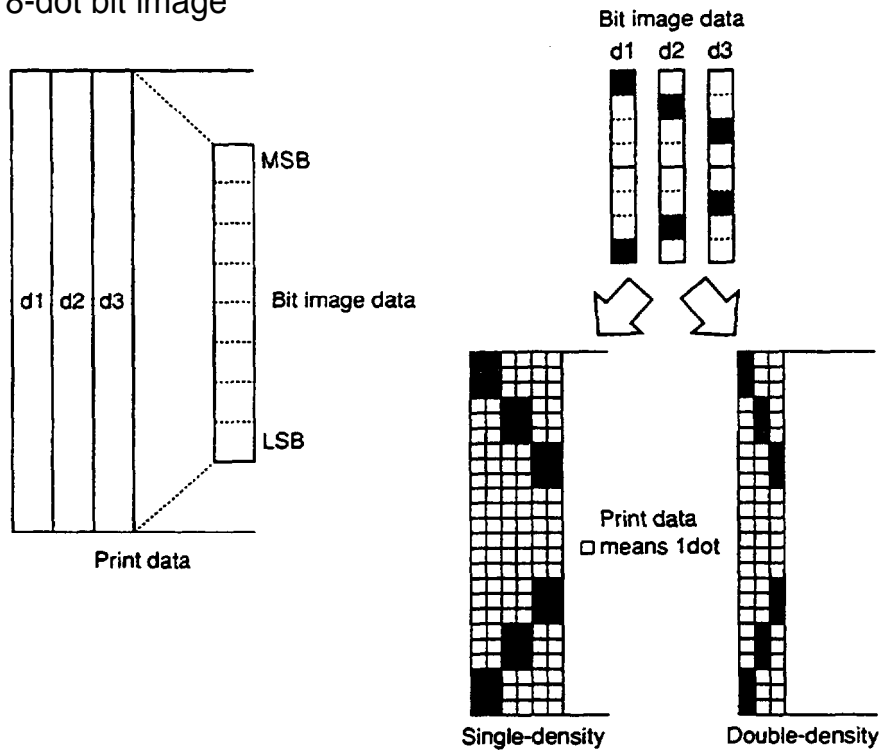

- 24-dot bit image

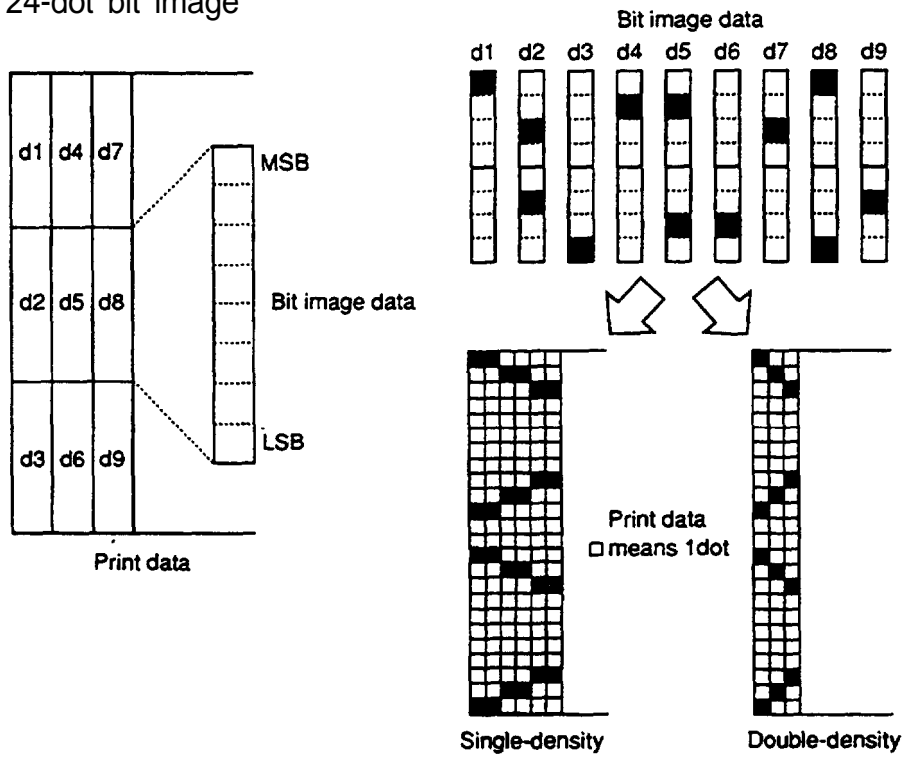

ESC 2

Name	Set 1/6 inch line spacing
Format	< 1B > _H < 32 > _H
Description	Sets the line spacing to 1/6 of an inch.

ESC 3

Name	Set line spacing using minimum units
Format	< 1B > _H < 33 > _H < n >
Range	$0 \leq n \leq 255$
Description	Sets the line spacing to $n/360$ of an inch.
Default	$n = 60$ (1/6 inch)
Reference	5-3 Miscellaneous Notes

ESC @

Name	Initialize printer
Format	< 1B > _H < 40 > _H
Description	Clears the data in the print buffer and resets the printer mode (to the same state as when the power is turned on).
Notes	- The DIP switches are not read again. . The data in the receive buffer is not cleared.

ESC D [n]k NUL

Name	Set horizontal tab positions
Format	< 1B > _H < 44 > _H [< n >]k < 00 > _H
Range	$1 \leq n \leq 255$ $0 \leq k \leq 32$
Description	Sets horizontal tab positions. - "n" specifies the column number from beginning of the line for setting a horizontal tab position. [$n = (\text{Column number}) - 1$]. For example, when a tab is set is to be set at column 9, $n = 8$. - "k" indicates the total number of horizontal tab positions to be set.

- A horizontal tab position is stored as the absolute value of (character width X *n*) measured from the beginning of the line. The character width includes the character right-side spacing, and double-width characters should be set with twice the width of normal characters.
- Up to 32 tab positions can be set. Data which exceeds 32 tab positions will be ignored.
- Set *<n>k* in ascending order and place a NUL code *<00>H* at the end.
- ESC D NUL clears all tabs. Any HT commands received after clearing will be ignored.
- When a data value *<n>k* is less than or equal to the preceding value *<n>k - 1*, the setting is considered to be finished. In this case, the following data is processed as normal data.
- When a data value *<n>k* exceeds the number of character printable on one line, set [(column number) = (the number of maximum printable columns) + 1].
- Horizontal tab positions remain unchanged if the character widths are changed after setting the horizontal tab positions.
- The default tab positions are at intervals of 8 characters (9th column, 17th, 25th,---) for Font A.

Notes

Default

Reference

HT

ESC J *n*

Name	Print and feed paper using minimum units
Format	<i>< 1B >_H< 4A >_H< n ></i>
Range	0 ≤ <i>n</i> ≤ 255
Description	Prints the data in the print buffer and feeds the paper <i>n/360</i> inches. <ul style="list-style-type: none"> - The predetermined line spacing remains unchanged. - Sets the print starting position to the beginning of the line. - Not defined.
Default	
Reference	5-3 Miscellaneous Notes

ESC R *n*

Name	Select international character set
Format	$\langle 1B \rangle_{\text{H}} \langle 52 \rangle_{\text{H}} \langle n \rangle$
Range	$0 \leq n \leq 10$
Description	<i>n</i> selects an international character set from the following table.

<i>n</i>	Country	<i>n</i>	Country
0	U.S.A.	6	Italy
1	France	7	Spain
2	Germany	8	Japan
3	U.K.	9	Norway
4	Denmark I	10	Denmark II
5	Sweden		

Default	$n = 0$
Reference	APPENDIX E Character Code Tables

ESC c3 *n*

Name	Select paper detectors to output signals
Format	$\langle 1B \rangle_{\text{H}} \langle 63 \rangle_{\text{H}} \langle 33 \rangle_{\text{H}} \langle n \rangle$
Range	$0 \leq n \leq 255$
Description	This function is available only for the TM-T60P/T80P. Select the paper detectors to output signals on the “paper-end status line”. - Each bit of <i>n</i> is used as follows.

Bit	Function	Value	
		0	1
0	Journal near-end	Invalid	Valid
1	Undefined		
2	Undefined		
3	Undefined		
4	Undefined		
5	Undefined		
6	Undefined		
7	Undefined		

Note

- In the TM-T60P/T80P, only the journal near-end detector can be detected and only the lowest of *n* is valid.

Default

n = 1

ESC c4 *n*

Name

Select paper detectors to stop printing

Format

< 1B >_H< 63 >_H< 34 >_H< *n*>

Range

0 ≤ *n* ≤ 255

Description

Selects the paper detectors used to stop printing.

- Each bit of *n* is used as follows:

Bit	Function	Value	
		0	1
0	Journal near-end	Invalid	Valid
1	Undefined		
2	Undefined		
3	Undefined		
4	Undefined		
5	Undefined		
6	Undefined		
7	Undefined		

- In the TM-T60P/T80P, only the journal near-end detector can be selected and only the lowest bit of *n* is valid.

Notes

- When a paper-end is detected by the journal detector, the printer goes OFF-LINE after printing stops.

Default

n = 0

Reference

ESC c5

ESC c5 *n*

Name

Enable/disable panel switches

Format

< 1B >_H< 63 >_H< 35 >_H< *n* >

Range

0 ≤ *n* ≤ 255

Description

Enables or disables all the paper feed switch.

- Only the lowest bit of *n* is valid.

When $n = \langle \text{* * * * * 0} \rangle_8$, the paper feed switch is enabled.

When $n = \langle \text{* * * * * 1} \rangle_8$, the paper feed switch is disabled.

Notes

- If the panel switches are disabled by this command, the paper feed switch is disabled. Therefore, paper cannot be fed with the paper feed switch.

Default

$n = 0$

ESC d n

Name

Print and feed paper n lines

Format

$\langle 1B \rangle_H \langle 64 \rangle_H \langle n \rangle$

Range

$0 \leq n \leq 255$

Description

Prints the data in the print buffer and performs n line feeds.
 - Sets the print starting position to the beginning of the line.
 - The predetermined line spacing remains unchanged.

Default

Not defined.

Reference

5-3 Miscellaneous Notes

ESC p m n1 n2

Name

Generate pulse

Format

$\langle 1B \rangle_H \langle 70 \rangle_H \langle m \rangle \langle n1 \rangle \langle n2 \rangle$

Range

$m = 0$
 $0 \leq n1 \leq n2 \leq 255$

Description

The pulse defined by $n1$ and $n2$ is output on connector pin m .

- m is specified as follows:

m	Connector Pin
0	Drawer kick out Pin 2
1	Drawer kick out Pin 5

- ON time is $n1 \times 2$ msec, and OFF time is $n2 \times 2$ msec.
- If m is out of range, the printer reads $n1$ and $n2$ but does not output a pulse.

Notes

Default

ESC t n

Name	Select character code table
Format	< 1B > _H < 74 > _H < n >
Range	$0 \leq n \leq 1$
Description	Selects page n from the character code table.
Default	$n = 0$
Reference	APPENDIX E Character Code Tables

ESC v

Name	Transmit printer status
Format	< 1B > _H < 76 > _H
Description	This function is available only for the TM-T60/T80. The current printer status is transmitted to the host computer.
Notes	<ul style="list-style-type: none">- The transmitted status is only one byte and the data is as shown in the following table.. When DTR/DSR control is selected, one byte is transmitted after confirming that the host computer is ready to receive data (DSR is SPACE). When XON/XOFF control is selected, one byte is transmitted without checking the DSR signal.- When DTR/DSR control is selected, if the host computer is not ready to receive data (DSR is MARK), the printer waits until it becomes ready.

Bit	Function	Value	
		0	1
0	Journal near-end	Paper is present	Paper is out
1	Undefined		
2	Journal end	Paper is present	Paper is out
3	Undefined		
4	Unused	Fixed to 0	
5	Undefined		
6	Undefined		
7	Undefined		

ESC u n

Name	Transmit peripheral device status
Format	< 1B > _H < 75 > _H < n >
Range	$n = 0$
Description	This function is available only for the TM-T60/T80. Transmits the status current of connector pin 3. - n is specified as follows:

n	Connector Pin
0	Drawer-kick connector Pin 3

Notes	<ul style="list-style-type: none">. The transmitted status is only one byte and the data is as shown in the following table.- If nothing is connected, bit 0 of n is always "1".. When DTR/DSR control is selected, one byte is transmitted after confirming that the host computer is ready to receive data (DSR signal is SPACE). When XON/XOFF control is selected, one byte is transmitted without checking the DSR signal.- When DTR/DSR control is selected, if the host computer is not ready to receive data (DSR is MARK), the printer waits until it becomes ready.
--------------	---

Bit	Function	Value	
		0	1
0	Pin 3 level	"LOW"	"HIGH"
1	Undefined		
2	Undefined		
3	Undefined		
4	Unused	Fixed to 0	—
5	Undefined		
6	Undefined		
7	Undefined		

Default	Not defined.
----------------	--------------

ESC { n

Name	Set/cancel upside-down character printing
Format	< 1B > _H < 7B > _H < n >

Range

$0 \leq n \leq 255$

Description

Sets or cancels upside-down character printing.

- Only the lowest bit of n is valid.

When $n = \langle \text{*****}1 \rangle_B$, upside-down character printing is set.

When $n = \langle \text{*****}0 \rangle_B$, upside-down character printing is canceled.

Notes

- The upside-down character specification rotates normal characters on the line by 180° and prints them.

- Valid only when input at the beginning of a line.

Default

$n = 0$

Example

When upside-down character printing is canceled.

When upsidedown character printing is set.

A	B	C	D	E	F	G
0	1	2	3	4	5	6



G	F	E	D	C	B	A
6	5	4	3	2	1	0

Paper feed direction

ESC V n

Name

Set/channel 90° cw(clockwise) rotated characters

Format

$\langle 1B \rangle_H \langle 56 \rangle_H \langle n \rangle$

Range

$0 \leq n \leq 1$

Description

Sets or cancels the 90° cw rotation of characters.

- When $n = 1$, 90° cw rotated characters are set.

- When $n = 0$, 90° cw rotated characters are canceled.

Default

ESC \$ $n1$ $n2$

Name

Set absolute position

Format

$\langle 1B \rangle_H \langle 24 \rangle_H \langle n1 \rangle \langle n2 \rangle$

Range

$0 \leq n1 \leq 255$

$0 \leq n2 \leq 1$

Description	Sets the print starting position to the specified number of dots (1/180 inch units) from the beginning of the line. - Divide the number of dots by 256. The integer answer is $n2$ and the remainder is $n1$. Therefore, the print starting position becomes $n1+n2 \times 256$ from the beginning of the line.
Note	- Any specification that exceeds the end of the line is ignored.
Default	Not defined.
Reference	ESC ¥

ESC ¥ $n1$ $n2$

Name	Set relative position
Format	< 1B > _H < 5C > _H < $n1$ >< $n2$ >
Range	$0 \leq n1 \leq 255$ $0 \leq n2 \leq 255$
Description	Moves the print starting position to the specified number of dots (1/180 inch units) from the current position. - A positive number specifies movement to the right, and a negative number specifies movement to the left. - Negative numbers are specified using the supplement of N; - $N = 65536 - N$ - Divide the number of dots by 256. The integer answer is $n2$ and the remainder is $n1$.
Notes	- Any specification exceeding the printable area will be ignored.
Default	Not defined.
Reference	ESC \$

GS k n [d] k NUL

Name	Print bar code
Format	< 1D > _H < 6B > _H < n >[< d >] k < 00 > _H
Range	$0 \leq n \leq 6$
Description	Selects a bar code system and prints the bar code. - Sets the print starting position to the beginning of the line. - n selects the bar code system from the following table.

- "d" indicates the characters to be printed and "k" indicates the number of characters to be printed.

n	Bar code system
0	UPC-A
1	IPC-E
2	JAN13(EAN)
3	JAN8(EAN)
4	CODE39
5	ITF
6	CODABAR

Notes

- . When data is present in the print buffer, this command is ignored.
- Performs the paper feeding required for printing the bar code, regardless of the current line spacing.
- . In each bar code system, if a character code "d" cannot be printed, the printer prints the processed data and the following data is treated as normal data.
- . When a bar code system with a fixed number of printing characters is selected, the number of characters "k" should be agreed with that number.
- . If the horizontal size exceeds one line, the excess data is not printed.

Default

$n = 0$

GS w n

Name	Select horizontal size (magnification) of bar code.
Format	< 1D > _H < 77 > _H < n >
Range	$2 \leq n \leq 4$
Description	Selects the horizontal size of the bar code.
Default	$n = 3$

GS h n

Name	Select height of bar code
Format	< 1D > _h < 68 > _h < n >
Range	$1 \leq n \leq 255$
Description	Selects the height of the bar code. - n specifies the number of dots in the vertical direction.
Default	$n = 162$

GS H n

Name	Select printing position of HRI characters
Format	< 1D > _h < 48 > _h < n >
Range	$0 \leq n \leq 3$
Description	Selects the printing position of HRI characters when printing a barcode. - n selects the printing position from the following table.

<i>n</i>	Printing position
0	Not printed
1	Above the bar code
2	Below the bar code
3	Both above and below the bar code

- HRI means Human Readable Interpretation.
 - HRI characters are printed using the font specified by GS f.
- Notes**
- Default** $n = 0$
- Reference** GS f

GS f n

Name	Select font for HRI characters.
Format	< 1D > _h < 66 > _h < n >
Range	$n = 0, 1$
Description	Selects a font for the HRI characters used when printing a bar code.

- *n* selects the font from the following table.

<i>n</i>	Font
0	Font A
1	Font B

. HRI means Human Readable Interpretation.

Notes

- HRI characters are printed at the position specified by GS H.

Default

n = 0

Reference

GS H

GS * *n1 n2 [d]n1Xn2X8*

Name

Define down-loaded bit image

Format

< 1D >_H< 2A >_H< *n1* >< *n2* >[< *d* >]*n1Xn2X8*

Range

$1 \leq n1 \leq 255$

$1 \leq n2 \leq 48$

$n1 \times n2 \leq 1311$

Description

Defines a down-loaded bit image with the number of dots specified by *n1* and *n2*.

- The number of dots in the horizontal direction is *n1X8*, and in the vertical direction is *n2X8*.
- "d" specifies the bit image data.
- After a down-loaded bit image is defined once, it is available until another definition is made, until ESC @ is executed, until ESC & is executed, or until the printer is turned off.

Notes

- The relationship between the bit image data and the transmitted dots is as follows:

. The user-defined characters and a down-loaded bit image cannot be defined at the same time. If this command is executed, the user-defined characters will be cleared.

Reference

GS /

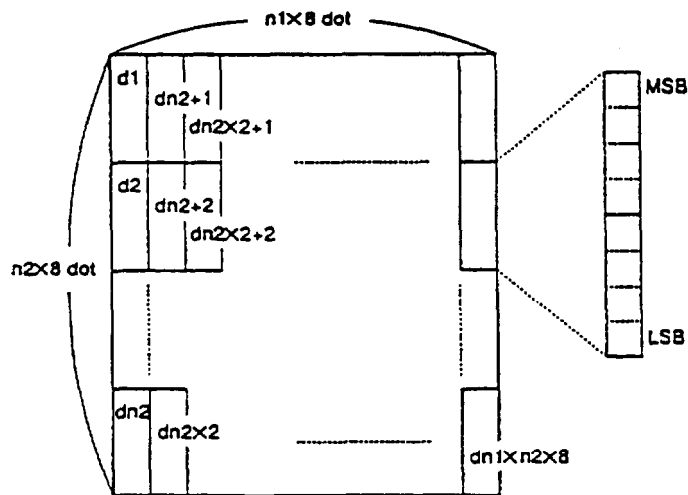

GS / m

Name	Print down-loaded bit image
Format	< 1D > _H < 2F > _H < m >
Range	$0 \leq m \leq 3$
Description	Prints a down-loaded bit image using the mode specified by <i>m</i> . - <i>m</i> selects the print mode from the following table.

<i>m</i>	Mode	Vertical Direction Dot Density	Horizontal Direction Dot Density
0	Normal mode	180 DPI	180 DPI
1	Double-width mode	180 DPI	90 DPI
2	Double-height mode	90 DPI	180 DPI
3	Quadruple mode	90 DPI	90 DPI

Notes	<ul style="list-style-type: none"> . If any data is present in the print buffer, this command is ignored. - If a down-loaded bit image has not been defined, this command is ignored. - If the down-loaded bit image data exceeds one line, the image will not be printed. - The user-defined characters and a down-loaded bit image cannot be defined at the same time.
--------------	--

Default Not defined.

Reference GS *

GS :

Name	Set starting/ending, position of macro definition
Format	< 1D > _H < 3A > _H
Description	Specifies the starting or ending position of the macro definition. - If this command is received while defining the macro, it ends the definition.
Notes	- If the macro range exceeds 2048 bytes, the excess data is not defined. - Even if the ESC @ command (initialize the printer) is performed, the macro definition is not cleared. Therefore, it possible to include ESC @ in the macro definition. - Normal printing operation is possible while defining the macro.
Default	Macro is not defined.
Reference	GS^

GS ^ n1 n2 n3

Name	Execute macro
Format	< 1D > _H < 5E > _H < n1 >< n2 >< n3 >
Range	$0 \leq n1 \leq 255$ $0 \leq n2 \leq 255$ $0 \leq n3 \leq 1$
Description	Executes a macro. <i>n1</i> : Specifies the number of times to execute the macro. <i>n2</i> : Specifies the waiting time for executing the macro. <i>n2</i> X 100 msec waiting time is required for one execution. <i>n3</i> : Specifies the macro executing mode. <ul style="list-style-type: none">• <i>n3</i> = 0 Continuous macro execution. Executes <i>n1</i> times continuously at the interval specified by <i>n2</i>.• <i>n3</i> = 1 Executes the macro with the paper feed switch. After waiting the period specified by <i>n2</i>, the error LED blinks and the printer

waits for the paper feed switch to be pressed.

After the paper feed switch is pressed, the printer executes the macro once.

The printer repeats this operation $n1$ times.

Notes

- If this command is received while defining the macro, the macro definition is aborted, and the definition is cleared.
- If the macro is not defined or if $n1$ is 0, nothing is executed.
- Paper cannot be fed with the paper feed switch while executing the macro when $n3$ is 1.

Default

Not defined.

Reference

GS :

ESC = n

Name

Select device

Format

$\langle 1B \rangle_{\text{H}} \langle 3D \rangle_{\text{H}} \langle n \rangle$

Range

$0 \leq n \leq 255$

Description

Selects a device to receive data from the host computer.

- If the printer is not selected, the TM-T60P ignores all received data until it is selected by this command.
- Each bit of n is used as follows:

Bit	Function	Value	
		0	1
0	Printetr	Invalid	Valid
1	Undefined		
2	Undefined		
3	Undefined		
4	Undefined		
5	Undefined		
6	Undefined		
7	Undefined		

Notes

- Even when the printer is not selected, it may enter the BUSY state due to printer operation.

Default

$n = 1$

ESC a n

Name Align positions
Format < **1B** > _n < **61** > _n < **n** >

Range $0 \leq n \leq 2$

Description Aligns all the data in one line to the specified position.
n specifies the alignment as follows:

<i>n</i>	Position
0	Align left
1	Align center
2	Align right

Notes • Valid only when input at the beginning of a line.

Default $n = 0$

Example

Align left	Align center	Align right
ABC	ABC	ABC
ABCD	ABCD	ABCD
ABCDE	ABCDE	ABCDE

6 - 4 Program Descriptions

■ TM-T60/T80

1. Introduction

The TM-T60/T80 is connected to the host computer by an RS-232C interface. The TM-T60/T80 is easily controlled by sending data and commands from the host computer.

The following examples use the main commands from MS-DOS BASIC.

2. Before Printing

- ① Connect TM-T60/T80m to the host computer, power supply, and the drawer while referring to Chapter 2.
- ② Check that the RS-232C cable is connected properly, and the host computer DIP-switches are set properly.
- ③ Check the TM-T60/T80 DIP-switches using the self test.
- ④ Connect the RS-232C cable to the host computer while referring to the computer's manual.

3. How to Write Program

Note: Omit step ① and ② if the drawer-kick connector is covered (the drawer-kick function is not available).

- ① For all programs, always first open device RS-232C.

```
100 OPEN "COM1:N81NN" AS #1
```

- ② Initialize the TM-T60/T80

```
110 PRINT #1,CHR$(27);"@' ;
```

"PRINT #1" is the order that sends data and commands through the device. This device is opened in step ①.

"CHR\$(27)" is the ESC code.

In order to execute ESC @ (Initialize the printer) send "@" following the ESC code.

Always write ";" at the end of the commands or BASIC will send a CR and LF code.

③ Sending Print Data

```
120 PRINT #1, "ABCDEF" ;CHR$(10);
```

Always send a LF code (CHR\$ (10)) after print data.

To execute printing, send a LF code or ensure the line is filled.

④ Selecting Character Font B

```
130 PRINT #1, CHR$(27); "!" ;CHR$(1);
```

```
140 PRINT #1, "ABCDEF" ;CHR$(10);
```

The number code that follows "!" alters the font, and also the mode for character size.

Therefore, the example above sets character Font B in lines 130 and 140; the style of "ABCDEF" is changed to the style of Font B.

Font	code	size	code	size	code	size	code	size
A	CHR\$(0)	Normal	CHR\$(16)	Double-height	CHR\$(32)	Double-width	CHR\$(48)	Quadruple
B	CHR\$(1)	Normal	CHR\$(17)	Double-height	CHR\$(33)	Double-width	CHR\$(49)	Quadruple

Font B and the size are selected until CHR\$ (27); "!" ; CHR\$ (x) ; is executed again or initialized.

⑤ Selecting character Font A and Double-width

```
150 PRINT #1, CHR$(27); "!" ;CHR$(48);  
160 PRINT #1, "ABCDEFGHJKLM" ;CHR$(10);
```

TM-T60

Font A (normal) : 32 characters per line.

Font A (double-width) : 16 characters per line.

⑥ Resetting the style to Normal.

```
170 PRINT #1, CHR$(27); "!" ;CHR$(0);  
180 PRINT #1, "ABCDEFGHJKLM" ;CHR$(10);
```

170 sets Font A to Normal. 180 sets the characters for printing.

⑦ Selecting the character code table

```
190 FOR I=240 TO 255  
200 PRINT #1, CHR$(I);  
210 NEXT I  
220 '  
230 PRINT #1, CHR$(27); "t" ;CHR$(1);  
240 '  
250 FOR I=240 TO 255  
260 PRINT #1, CHR$(I);  
270 NEXT I
```

Page 0 characters, 190~210.

Page 1 characters, 250~270.

Refer to ESC t n.

⑧ Selecting international character codes

```
280 PRINT #1, CHR$(91);CHR$(92);CHR$(93);CHR$(94);CHR$(10);
290 PRINT #1, CHR$(27); "R" ;CHR$(1);
300 PRINT #1, CHR$(91);CHR$(92);CHR$(93);CHR$(94);CHR$(10);
```

280 prints 4 U. S. A characters. (default)

300 prints 4 French characters.

Refer to ESC R n

⑨ Resetting Printer functions

```
310 PRINT #1, CHR$(27); "@";
```

Initialize printer again.

⑩ Printing bar codes

```
320 PRINT #1, CHR$(29); "H" ;CHR$(2);
330 PRINT #1, CHR$(27); "$";CHR$(40);CHR$(0);
340 PRINT #1, CHR$(29); "k";CHR$(2);"012345678901";CHR$(0);
```

In order to print the bar code, you must send the GS code.

(Refer to Appendix E, GS code.)

"CHR\$ (29)" is the GS code.

320 prints HRI (Human Readable Interpretation) as bar codes.

Refer to GS H n

330 sets the print starting position to the specified number of dots (40) . Refer to ESC \$ n1 n2.

340 prints the bar code ; "k" executes printing. (Refer to GS k n [d]k NUL.) "CHR\$ (2)" selects the JAN 13 Bar code system.

The 12 characters, "012345678901" are print data.

A check-digit is added by the printer because 12 characters are sent, and "012345678901" is printed.

"CHR\$ (0)" must always be used as the last command (representing end of data).

⑪ Using the drawer kick

```
350 PRINT #1, CHR$(27);"p";CHR$(0);CHR$(10);CHR$(100);
```

The "p" generates a specified pulse;

Refer to ESC p m n1 n2.

In line 350, the module terminal of the drawer kick outputs a **20-ms** pulse followed by a 200-ms wait.

⑫ How to read the status of the drawer kick

```
360 PRINT #1, CHR$(27);"u";CHR$(0);  
370 A$=INPUT$(1, #1)  
380 IF A$=CHR$(0) THEN PRINT "DRW:L"  
390 IF A$=CHR$(1) THEN PRINT "DRW:H"
```

The "u" command in line 360 transmits the status of the drawer kick to printer. Refer to ESC u n.

370 receives the data from the printer through RS-232C.

380 and 390 display the status of the drawer kick on the CRT.

⑬ Close RS-232C

```
400 CLOSE #1
```

RS-232C must be closed by the computer using this command.

* * * * *

Program List

* * * * *

in MS-DOS BASIC

HOST COMPUTER:EPSON PC-286

```
100 OPEN "COM1:N81NN" AS #1
110 PRINT #1,CHR$(27);"@";
120 PRINT #1,"ABCDEF";CHR$(10);
130 PRINT #1,CHR$(27);"!";CHR$(1);
140 PRINT #1,"ABCDEF";CHR$(10);
150 PRINT #1,CHR$(27);"!";CHR$(48);
160 PRINT #1,"ABCDEFGHIJK";CHR$(10);
170 PRINT #1,CHR$(27);"!";CHR$(0);
180 PRINT #1,"ABCDEFGHIJK";CHR$(10);
190 FOR I=240 TO 255
200     PRINT #1,CHR$(I);
210 NEXT I
220'
230 PRINT #1,CHR$(27);"t";CHR$(1);
240'
250 FOR I=240 TO 255
260     PRINT #1,CHR$(I);
270 NEXT I
280 PRINT #1,CHR$(91);CHR$(92);CHR$(93);CHR$(94);CHR$(10);
290 PRINT #1,CHR$(27);"R";CHR$(1);
300 PRINT X1,CHR$(91);CHR$(92);CHR$(93);CHR$(94);CHR$(10);
310 PRINT #1,CHR$(27);"@";
320 PRINT #1,CHR$(29);"H";CHR$(2);
330 PRINT #1,CHR$(27);"$";CHR$(40);CHR$(0);
340 PRINT #1,CHR$(29);"k";CHR$(2);"012345678901";CHR$(0);
350 PRINT #1,CHR$(27);"p";CHR$(0);CHR$(10);CHR$(100);
360 PRINT #1,CHR$(27);"u";CHR$(0);
370 A$=INPUT$(1,#1)
380 IF A$=CHR$(0) THEN PRINT "DRW:L"
390 IF A$=CHR$(1) THEN PRINT "DRW:H"
400 CLOSE #1
```

■ TM-T60P/T80P

Except for the different interface connectors accommodated by the two types of the printer TM-T60/T80 and TM-T60P/T80P, the description for the TM-T60P/T80P printer is same with the TM-T60/T80's which are mentioned before.

However, omit step 12, because the TM-T60P/T80P can know the status of the drawer-kick through pin 34 of the parallel interface connector.

```
* * * * * * * * * *          Program List          * * * * * * * * * *
                                                                in MS-DOS BASIC
                                                                HOST COMPUTER:EPSON PC-286

110 LPRINT CHR$(27);"@";
120 LPRINT "ABCDEF" ;CHR$(10);
130 LPRINT CHR$(27);"!";CHR$(1);
140 LPRINT "ABCDEF";CHR$(10);
150 LPRINT CHR$(27);"!";CHR$(48);
160 LPRINT "ABCDEFGHJK";CHR$(10);
170 LPRINT CHR$(27);"!";CHR$(0);
180 LPRINT "ABCDEFGHJK";CHR$(10);
190 FOR I=240 TO 255
200 LPRINT CHR$(I);
210 NEXT I
220 '
230 LPRINT CHR$(27);"t";CHR$(1);
240 '
250 FOR I=240 TO 255
260 LPRINT CHR$(I);
270 NEXT I
280 LPRINT CHR$(91);CHR$(92);CHR$(93);CHR$(94);CHR$(10);
290 LPRINT CHR$(27);"R";CHR$(1);
300 LPRINT CHR$(91);CHR$(92);CHR$(93);CHR$(94);CHR$(10);
310 LPRINT CHR$(27);"@";
320 LPRINT CHR$(29);"H";CHR$(2);
330 LPRINT CHR$(27);"S";CHR$(40);CHR$(0);
340 LPRINT CHR$(29);"k";CHR$(2);"012345678901"CHR$(0);
350 LPRINT CHR$(27);"p";CHR$(0);CHR$(10);CHR$(100);
```

APPENDIX

APPENDIX A General Specifications

1. Printing specifications

- (1) Print method: Thermal line printing
- (2) Dot density: 180 dpi
- (3) Printing direction: Unidirectional with friction feed
(Manual reverse feeding is impossible)
- (4) Print width (TM-T60/T60P): 54mm, 384 dot positions
(TM-T80/T80P): 72mm, 512 dot positions
- (5) Characters per line (TM-T60/T60P): 32 (Font A)
: 42 (Font B)
(TM-T80/T80P): 42 (Font A)
: 56 (Font B)
- (6) Character spacing: 0.28 mm (Font A)
0.28 mm (Font B)
Programmable by control command.
- (7) Printing speed (TM-T60/T60P): Approx. 12 lines/second (1/6 inch feed)
: Approx. 18 lines/second (1/9 inch feed)
: Approx . 2.0 inches/second
(TM-T80/T80P): Approx . 9 lines/second (1/6 inch feed)
: Approx . 13 lines/second (1/9 inch feed)
: Approx . 1.5 inches/second
: Printing speed may slow down depending on the data transmission speed and combination of control commands.

(8) Paper feeding speed

(TM-T60/T60P): Approx. 2.0 inches/second
(Approx. 50.0 mm/second)

(TM-T80/T80P): Approx. 1.5 inches/second
(Approx. 38.0 mm/second)

(9) Line spacing:

1/6 inch (4.23 mm) default
Programmable by control command.
(Minimum 1/360 inch)

2. Character specifications

(1) Character sets: Alphanumeric: 95
 Enlarged graphics: 128X2 pages
 International: 32

(2) Character structure: Font A: 12X24 (includes the horizontal
 2-dot space)
 Font B: 9X17 (includes the horizontal
 2-dot space)
 Default: Font A

(3) Character size: 1.41 mm (W)X3.39 mm (H) (Font A)
 0.99 mm (W)X2.40 mm (H) (Font B)

Table A.1 Character Sizes

	Standard		Double-height		Double-Width		Quadruple	
	WXH (mm)	CPL	WxH (mm)	CPL	WXH (mm)	CPL	WXH (mm)	CPL
Font A (12X24)	1.41 x3.39	32 *42	1.41 x6.77	32 *42	2.62X3.39	16 *21	2.62X6.77	16 *21
Font B (9X17)	0.99x2.40	42 *56	0.99x4.60	42 *56	1.96x2.40	21 *28	1.96x4.60	21 *28

Space between characters is not included.

CPL = Characters per line.

* : TM-T80/T80P

3. Near-end detector

- (1) Detection method: Microswitch
- (2) Roll paper core diameter: Inside diameter: 12 mm
Outside diameter: 18 mm
- (3) Adjustment mechanism: Adjusting screw
The near-end detection processing is programmable by control command.
- (4) Adjustment units: Approx. 2 mm/scale division

4. Paper

- (1) Paper types: Specified thermal paper
- (2) Paper thickness: $65 \pm 5 \mu\text{m}$
- (3) Form: Roll paper
- (4) Paper width (TM-T60/T60P): $60 \pm 0.1 \text{ mm}$
(TM-T80/T80P): $80 \pm 0.1 \text{ mm}$
- (5) Roll size: Roll diameter: Max. $\varnothing 83 \text{ mm}$
Taken up paper roll width: $60 \pm 0.1^{0.5} \text{ mm}$
- (6) Specified paper (TM-T60/T60P): Roll paper model No. : NTP060-80
(TM-T80/T80P): Roll paper model No. : NTP080-80
(NAKAGAWA SEISAKUJO)
[Original paper model No.: TF50KS-E
(JUJO PAPER CO., LTD)]
- (7) Roll paper core: Inside diameter: 12 mm
Outside diameter: 18 mm
Paper should never be pasted to the paper core.

5. Receive buffer

- Either 4 Kbytes or 45 bytes, selectable by DIP switch (TM-T60/T80)
- Either 4 Kbytes or 0 bytes, selectable by DIP switch (TM-T60P/T80P)

6. Electrical characteristics

- (1) Supply voltage: 24 VDC $\pm 7\%$
(Optional power supply: PS-130)
- (2) Current consumption: Operating: Mean: Approx . 1.3 A
(Print duty: 30%)

Peak: Approx. 6.0 A
(Print duty: 100%)

Standby: Approx . 100mA

7. EMI (by using Epson PS-130)

- (1) FCC: -Class A
- (2) FTZ: Class B

8. Reliability

MCBF: 3,500,000 lines (Printing Font A characters)

9. Environmental conditions

- (1) Temperature Operating: 5 to 40°C
Storage: -10 to 50°C (except for paper)
- (2) Humidity Operating : 30 to 85°C (non-condensing)
Storage: 30 to 90% (non-condensing, except for paper)

10. External dimensions and weight

(TM-T60/T60P) Height:	123 mm
Width:	124 mm
Depth:	201 mm
weight:	Approx. 0.8 Kg
(TM-T80/T80P) Height:	125 mm
Width:	145 mm
Depth:	216 mm
Weight:	Approx. 1 Kg

11. Case color

EPSON standard gray

APPENDIX B Connectors

1. Connectors

TM-T60/T80

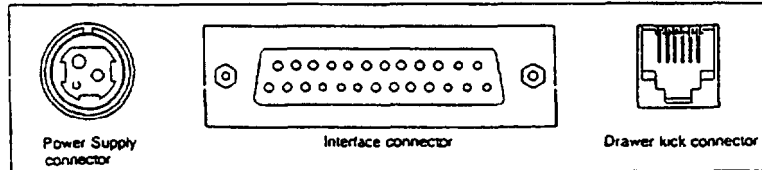

TM-T60P/T80P

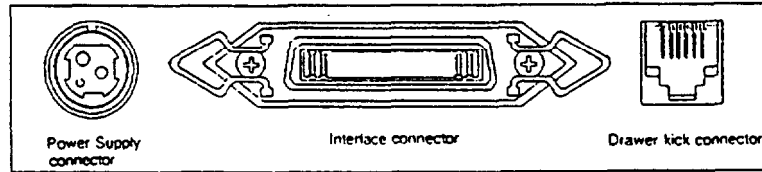

2. Interface connectors

Refer to APPENDIX C Interfaces

3. Power supply connector

This connector is used to connect an external power source.

(1) Pin assignment:

Pin 1: +24 VDC

Pin 2: GND

Pin 3: Unconnected

SHELL: Connected to the frame ground (FG) at the printer side.

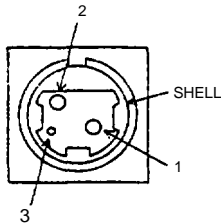

(2) Model

User side:

Connector: TCP8927-63-1110

(Hosiden or equivalent)

Cable: E-core shielded (AWG22X2)

Printer side: TCS7960-53-2010 (Hosiden or equivalent)

NOTE: Start the external power supply after connecting the external power supply -

4. Drawer-kick connector (Modular connector)

NOTE: If the drawer-kick connector is covered, the drawer-kick function is not available.

(1) Pin assignment: Printer side connector: TM5RJ3-66 (HIROSE) or equivalent

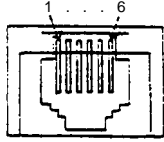

User-side plug: Standard 6-pin modular jack (RJ11 Telephone jack)

Table B-I. Drawer-kick out Connector Pin Assignment

Pin Number	Signal Name	Sender	Connected to:	Function
1	FG	-	Cash drawer	Frame ground.
2	L1(-)	Printer	cash drawer	Drawer-kick drive signal L1.
3	SW(+)	Cash drawer	cash drawer	connected to the (+)side of the open/close detection switch on the cash drawer. Pulled up through a 10 k Ω resistor on the printer side.
4	L(+)	Printer	Cash drawer	+24 VDC for drawer kick is supplied.
5	L2(-)	Printer	Cash drawer	Drawer-kick drive signal L2.
6	SW(-)		Cash drawer	Connected to the (-)side of the open/close detection switch on the cash drawer. Connected to the signal ground on the printer side.

(2) Drawer-kick drive signal

This signal outputs the pulses specified by the **ESC p** command.

The SW(+) state is checked by the host computer using the **ESC u** Command.

Electrical characteristics

- (a) Signal output current: Maximum -1 A (510 ms or less)
- (b) Power supply output voltage: 24 VDC (typical)
- (c) Power supply output current: Maximum 1A (510 ms or less)
- (d) Output waveform: Refer to Figure B-2.

NOTE 1: These are not output during printing.

2: Drawer-kick drive signals L1 and L2 cannot be output at the same time.

(3) Drawer open/close signal

SW(+) signal level: "LOW" = 0 to 0.5 V
 "HIGH" = 3 to 5 V

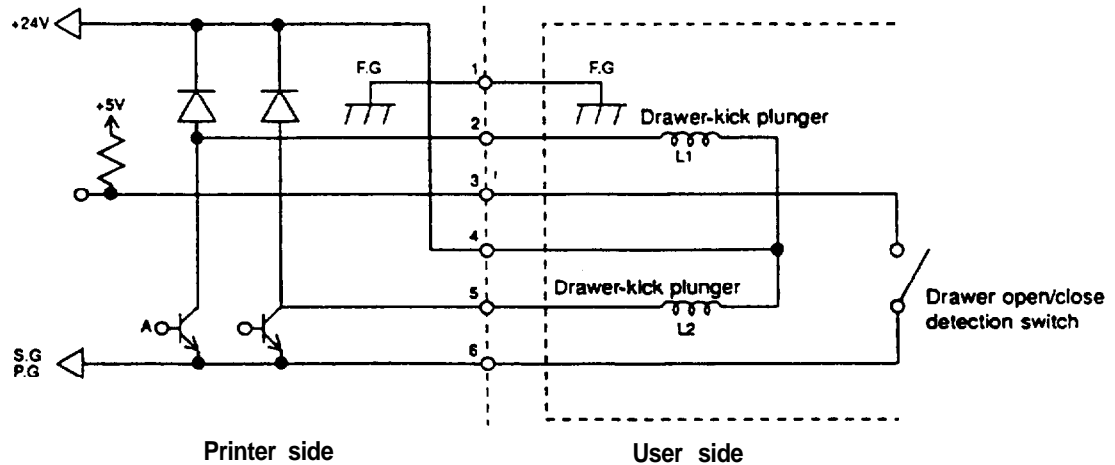

Figure E1. Drawer kick-out Signal Interface Circuit

NOTE: Only the solenoid can be connected to the terminal of the drawer-kick connector drive signal.

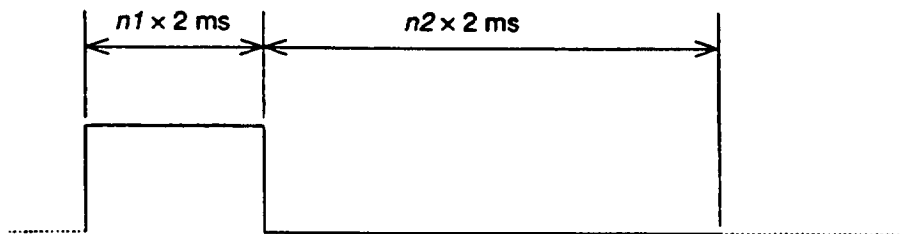

Figure B-2. Drawer kick-out Drive Signal

The waveform shown in Figure B-2. is output at Point A in Figure B-1 .
 ($n1$ (ON time) and $n2$ (OFF time) depend on the ESC p command.)
 See APPENDIX D Notes on Using the Drawer kick-out Connector.

APPENDIX C Interfaces

■ TM-T60/T80

1. Specifications (RS-232C compatible)

Data transmission:	Serial
Synchronization:	Asynchronous
Handshaking:	DTR/DSR or XON/XOFF control
Signal level:	MARK = -3 to -15 VDC: Logic "1" SPACE = +3 to +15 VDC: Logic "0"
Baud rates:	1200, 4800, 9600, 19200 bps
Bit length:	8 bits
Parity:	Invalid, even, odd
Stop bits:	1 bit or more
Connector:	D-SUB 25 pin connector

2. Interface connector terminal assignments and signal functions

Pin Number	Signal Name	Signal Direction	Function
1	FG (GND)	-	Frame ground
2	SD (TXD)	Output	Transmit data
3	RD (RXD)	Input	Receive data
4	RS (RTS)	Output	The same signal as DTR
6	DR (DSR)	Input	This signal indicates whether the host computer can or cannot receive data. "SPACE" indicates that the host computer can receive data and "MARK" indicates that the host computer cannot receive data. When DTR/DSR control is selected, the printer transmits data after checking this signal. When XON/XOFF control is selected, the printer does not check this signal.
7	SG (GND)		Signal ground
20	ER (DTR)	Output	This signal indicates whether the printer can or cannot receive data. when DTR/DSR control is selected. "SPACE" indicates that the printer can receive data and "MARK" indicates that the printer cannot receive data. The signal turns to "MARK" in the following cases: When the receive buffer becomes full. When the printer is OFF-LINE. When XON/XOFF control is selected, the signal is always "SPACE" except in the following cases: -During the period from when the power is turned on to when data reception becomes possible after the printer initialization is completed. When an error has occurred. During and after the self-test printing.

3. Serial interface

(a) Receive data

Either DTR/DSR or XON/XOFF control is selectable. Changes in DTR signal and XON/XOFF transmission are as follows:

[DTR MARK]	<ul style="list-style-type: none">* The period from when the power is turned on to when the printer is first ready to receive data.* In an error state.* When the remaining space in the receive buffer becomes 10 bytes.
[DTR SPACE]	<ul style="list-style-type: none">* When the printer is first ready to receive data after power-on.* When the remaining space in the receive buffer becomes 20 bytes.
[XON Transmission]	<ul style="list-style-type: none">* When the printer first becomes ready to receive data after turning the power-on.* When the remaining space in the receive buffer becomes 20 bytes.
[XOFF Transmission]	<ul style="list-style-type: none">* In an error state.* When the remaining space in the receive buffer becomes 10 bytes.

(b) Transmit data (Status information transmission)

When DTR/DSR control is selected, data is transmitted after confirming that DSR is SPACE. When DTR/DSR control isn't selected, data is transmitted regardless of the DSR state.

■ TM-T60P/T80P

1. Specifications (based on Centronics)

Data transmission:	8-bit parallel
Synchronization:	<u>STROBE</u> pulse supplied by host computer
Handshaking:	<u>ACKNLG</u> and BUSY
Logic level:	All of the interface control signals are TTL compatible
Connector:	ADS-B36BLFDRI76 (HONDA Correspondence Industry) or equivalent

2. Interface connector terminal assignments and signal functions

Pin Number	Signal Name	Signal Direction	Function
1	STROBE	Input	STROBE pulse for reading data. Normally, this signal is "HIGH". just after it goes "LOW", the printer reads the data. Pulse width must be 0.5 μ s or more at the receive terminal.
2	DATA 1	Input	These signals are the eight parallel data bits. "HIGH" indicates that the bit is "1" and "LOW" indicates that is "0".
3	DATA 2	Input	
4	DATA 3	Input	
5	DATA 4	Input	
6	DATA 5	Input	
7	DATA 6	Input	
8	DATA 7	Input	
9	DATA 8	Input	
10	ACKNLG	Output	This signal indicates that the printer is ready to receive data. Under normal conditions, it is "HIGH" and goes "LOW" for approx. 10 μ s.
11	BUSY	Output	This signal indicates whether the printer can or cannot receive data. When this signal is "HIGH", it indicates that the printer cannot receive data. When it is "LOW", it indicates that the printer is ready to receive data.
12	PE	Output	This indicates whether paper is present or not. "HIGH" indicates that the paper has run out. "LOW" indicates the paper is present.
13	SLCT	Output	This signal is pulled up to +5V through 3.3K Ω resistor.
14	<u>AUTO</u> <u>FEED XT</u>	Input	If this signal is "LOW", printing and line feed are performed automatically by CR command.
15	NC		
16	GND		Signal ground
17	CHASSIS GND		chassis ground
18	NC		
19 or 30	GND		Signal ground

Pin Number	Signal Name	Signal Direction	Function
31	$\overline{\text{INIT}}$	Input	Printer hardware reset signal. Normally, this signal is "HIGH". The printer is reinitialized, just as when power is turned on, by receiving a "LOW" pulse of 50 μs or more.
32	ERROR	Output	This signal indicates whether the printer is in an error state or not. It is "LOW" in the following cases. <ul style="list-style-type: none"> • During the period from when the power is turned on to when the printer initialization completes. • During the self test printing. • In the OFF-LINE state. • In a mechanical error state.
33	GND	—	Signal ground
34	DRAWER KICK STATUS	Output	Pulled up to +5 V through a 3.3 K Ω resistor, and the status signal of the drawer-kick connector is directly output.
35	+5 V	Output	This signal is pulled up to +5 V through a 3.3 K Ω resistor.
36	NC	—	

- NOTES: 1. For interface wiring, be sure to use a twisted-pair cable for each side and connect the return side to the signal GND level. To prevent noise, these cables should be shielded and connected to the chassis of the host computer.
2. All of the interface conditions are based on TTL levels. The rising time and falling time of any signal should be 0.2 μs or less.
3. Never transmit data without checking $\overline{\text{ACKNLG}}$ and BUSY. (Data should only be transmitted to this printer after confirming that $\overline{\text{ACKNLG}}$ is active, or when BUSY is "LOW".)
4. The interface cable should be as short as possible.

3. Parallel interface timing chart

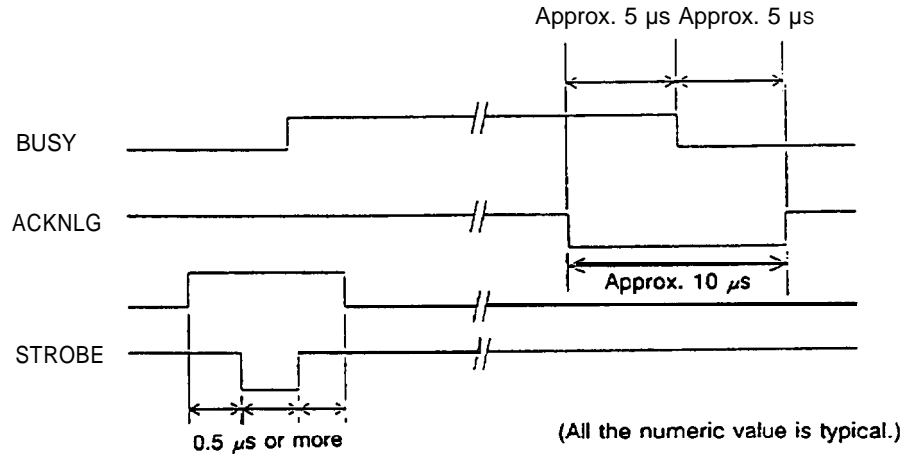

Reception of data is controlled by the $\overline{\text{ACKNLG}}$ or BUSY signal. The BUSY signal goes "HIGH" depending on whether the receive buffer is available or not as follows:

- During the period from when power is turned on to when the printer initialization completes.
- During the self test printing
- During data entry
- in the OFF-LINE state
- in the receive buffer full state.
- in a mechanical error state.

NOTE: • When the remaining space in the receive buffer is **10 bytes** or less, the printer becomes "receive buffer full".

- If the remaining space in the receive buffer is 0 byte, the received data will be ignored.

APPENDIX D Notes on Using the Drawer kick-out Connector

1) Usage conditions of drawer kick-out connector (Refer to APPENDIX B).

Because drawer specifications differ greatly depending on the manufacture and the part No., make sure that the specifications of the drawer to be used meet the following conditions before connecting it to the drawer kick-out connector of this printer. These conditions also apply to any devices that use the drawer kick-out connector.

Any devices that do not satisfy all the following conditions must not be used.

[Conditions]

- A load must be provided between the drawer kick-out connector pins 4 and 2 or between 4 and 5.(* 1)
 - When the drawer open/close signal is used, the drawer open/close switch must be provided between the drawer kick-out connector pins 3 and 6.(* 2)
 - The resistance of the drawer open/close solenoid load shall be 24 Ω or more, or the output current shall be 1 A or less.(* 3)
- . Be sure to use the drawer kick-out connector pin 4 (24 V power output) to drive the device. Never connect any other power supply to the drawer kick-out connector. (* 4)
- in this case the peak current is 1 A, and the energizing conditions described in 2) must be followed.

NOTES: * 1. Operation of this printer with incorrenctly installed devices voids the warranty.

* 2. Connecting devices other than the switch voids this printer's warranty.

* 3. if a device with the resistance of less than 24 Ω or the input current of over 1 A is used, the resulting overcurrent could damage the device.

* 4. Operation of this printer with devices other than those specified voids the warranty.

2) Notes on using the specified pulse generation command (ESC p)

When the drawer is connected to the drawer kick-out connector and driven using the specified pulse generation command (ESC P), specify the parameters $n1$ and $n2$ in this command so that they will meet the following conditions.

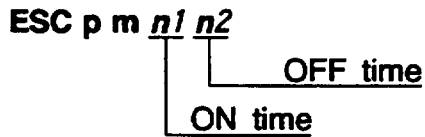

$$\frac{\text{ON time}}{\text{ON time} + \text{OFF time}} \leq 0.2 \quad (\text{Formula D-1})$$

or $\text{OFF time} \geq \text{ON time} \times 4$ (Formula D-2)

When the drawer is driven in accordance with the conditions above, the signal waveform of the drive signal is as shown in Figure D-1 .

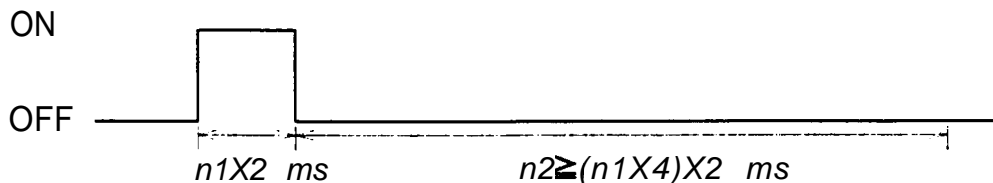

Figure D-1 . Drawer Drive Signal Waveform

Because ON time differs depending on the drawer used, set the ON time according to the drawer specifications. However, drawers which do not meet formulas D-1 and D-2 cannot be used.

- 3) Notes on using the drawers that do not satisfy the conditions described in 2). When the values of $n1$ and $n2$ are determined according to the conditions described in 2), the setting value range of $n1$ is 0 to 255 and the $n1$ value range inevitably becomes $n1 \leq 63$, and the maximum ON time is 126 ms. If the drawer needs more than 126 ms ON time, set the ON time and OFF time so that they can satisfy Formula D-3.

$$\frac{\text{ON time}}{\text{ON time} + (\text{OFF time} + \alpha)} \leq 0.2 \quad (\text{Formula D-3})$$

α : the sequence processing time

NOTE: α means the drawer driving prohibited period from the end of OFF time to the start of ON.

The following shows an example program used when the drawer connected to the drawer drive signal 1 is driven using an ON time of 200 ms.

```

PRINT #1, CHR$(&H1B);"P";CHR$(0);CHR$(100);CHR$(250);
GOSUB*WAIT3OOMS
*WAIT3OOMS
300[ms] wait routine ] (* NOTE)
RETURN

```

ON time 200ms OFF time 500ms

NOTE: *This part is indicated in Formula D-3. Set this value so that it can satisfy Formula D-3 (or provides an internal processing time at least as long as the wait routine time.)

When the drawer is driven according to the conditions above, the drive waveform is as shown in Figure D-2.

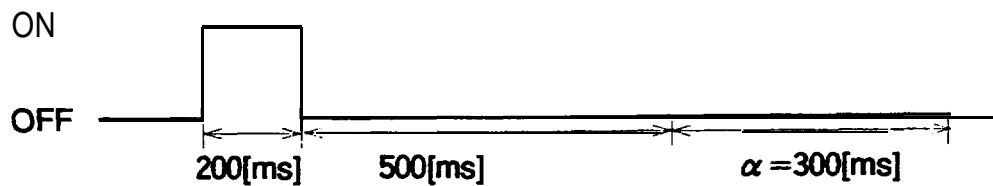

Figure D-2. Example Drawer Drive Signal Waveform

APPENDIX E Character Code Tables

■ Page 0 (Extended graphics)

	HEX	0	1	2	3	4	5	6	7	8	9	A	B	C	D	E	F
HEX	BIN	0000	0001	0010	0011	0100	0101	0110	0111	1000	1001	1010	1011	1100	1101	1110	1111
0	0000	NUL	SP	0	@	P		p	Ç	É	á		Ł	ł	α	≡	
1	0001	XON	!	1	A	Q	a	q	ü	æ	í	⌘	⊥	⌘	β	±	
2	0010		"	2	B	R	b	r	é	Æ	ó	■	⌘	π	Γ	≥	
3	0011	XOFF	#	3	C	S	c	s	â	ô	ú		†	Ł	π	≤	
4	0100		\$	4	D	T	d	t	ä	ö	ñ	†	-	Ł	Σ	∫	
5	0101		%	5	E	U	e	u	à	ò	ñ	†	+	Ł	σ	∫	
6	0110		&	6	F	V	f	v	â	û	æ	†	†	Ł	μ	÷	
7	0111		'	7	G	W	g	w	ç	ù	ó	†	†	Ł	τ	≈	
8	1000		(8	H	X	h	x	ê	ÿ	¿	†	Ł	†	φ	°	
9	1001	HT)	9	I	Y	i	y	ë	ö	-	†	†	Ł	θ	•	
A	1010	LF	*	:	J	Z	j	z	è	Ü	-	†	Ł	Ł	Ω	•	
B	1011	ESC	+	;	K	[k	{	ÿ	φ	½	†	†	Ł	δ	√	
C	1100		,	<	L	\	l		î	£	¼	†	†	Ł	∞	∞	
D	1101	CR	GS	=	M]	m	}	ï	¥	¾	†	†	Ł	∅	²	
E	1110		.	>	N	^	n	~	Ä	Ŕ	«	†	†	Ł	€	■	
F	1111		/	?	O	_	o	SP	Å	f	»	†	†	Ł	∅	SP	

HEX	BIN	0	1	2	3	4	5	6	7	8	9	A	B	C	D	E	F	
0	0000	NUL		SP	0	@	P		p	-	┌	SP	-	夕	ミ	ニ	×	
1	0001		XON	!	1	A	Q	a	q	-	└	。	ア	チ	ム	フ	円	
2	0010			"	2	B	R	b	r	-	┌	「	イ	ツ	メ	キ	年	
3	0011		XOFF	#	3	C	S	c	s	-	└	」	ウ	テ	モ	コ	月	
4	0100			\$	4	D	T	d	t	-	┌	、	エ	ト	ヤ	▲	日	
5	0101			%	5	E	U	e	u	-	└	。	オ	ナ	ユ	▲	時	
6	0110			&	6	F	V	f	v	-	┌	ヲ	カ	ニ	ヨ	▲	分	
7	0111			'	7	G	W	g	w	-	└	」	ア	キ	ヌ	ラ	▲	秒
8	1000			(8	H	X	h	x	-	┌	「	イ	ク	ネ	リ	♠	〒
9	1001	HT)	9	I	Y	i	y	-	└	」	ウ	ケ	ノ	ル	♥	市
A	1010	LF		*	:	J	Z	j	z	-	┌	」	エ	コ	ハ	レ	♦	区
B	1011		ESC	+	;	K	[k	{	-	└	」	オ	サ	ヒ	ロ	♣	町
C	1100			,	<	L	\	l		-	┌	「	ヤ	シ	フ	ワ	●	村
D	1101	CR	GS	-	=	M]	m	}	-	└	」	ユ	ス	ヘ	ン	○	人
E	1110			.	>	N	^	n	~	-	┌	」	ヨ	セ	ホ	、	/	■
F	1111			/	?	O	_	o	SP	+	└	」	ツ	ソ	マ	。	\	SP

■ International character set

Country	hex dec	ASCII Code											
		23 35	24 36	40 64	5B 91	5C 92	5D 93	5E 94	60 96	7B 123	7C 124	7D 125	7E 126
0 USA		#	\$	@	[\]	^	_	{		}	~
1 France		#	\$	à	•	ç	š	ˆ	˜	é	ù	è	ˆ
2 Germany		#	\$	š	Ä	Ö	Ü	ˆ	˜	ä	ö	ü	ß
3 United Kingdom		£	\$	@	[\]	^	_	{		}	~
4 Denmark I		#	\$	@	Æ	Ø	Å	ˆ	˜	æ	ø	å	ˆ
5 Sweden		#	□	É	Ä	Ö	Å	Û	é	ä	ö	å	ü
6 Italy		#	\$	@	•	\	é	ˆ	˜	ù	à	ò	è
7 Spain		℥	\$	@	ı	Ñ	¿	ˆ	˜	ˆ	ñ	}	~
8 Japan		#	\$	@	[¥]	ˆ	˜	{		}	~
9 Norway		#	□	É	Æ	Ø	Å	Û	é	æ	ø	å	ü
10 Denmark II		#	\$	É	Æ	Ø	Å	Û	é	æ	ø	å	ü

APPENDIX F Command Summary

T60/T80	T60P/T80P	Command	Command Name
O	O	HT	Horizontal tab
O	O	LF	Print and line feed
N.A.	O	CR	Print and carriage return
O	O	ESC SP	Set character right-side spacing
O	O	ESC !	Select print mode
O	O	ESC %	Set/cancel user-defined character set
O	O	ESC &	Define userdefined characters
O	O	ESC *	Set bit image mode
O	O	ESC 2	Set 1/6 inch line spacing
O	O	ESC 3	Set line spacing using minimum units
O	O	ESC @	Initialize printer
O	O	ESC D	Set horizontal tab positions
O	O	ESC J	Print and feed paper using minimum units
O	O	ESC R	Select international character set
N.A.	O	ESC c3	Select paper detectors to output signals
O	O	ESC c4	Select paper-end detectors to stop printing
O	O	ESC c5	Enable/disable panel switches
O	O	ESC d	Print and feed <i>n</i> lines
O	O	ESC p	Generate pulse
O	O	ESC t	Select character code table
O	N.A.	ESC v	Transmit printer status
O	N.A.	ESC u	Transmit peripheral device status
O	O	ESC {	Set/cancel upside-down character printing
O	O	ESC V	Set/cancel 90° cw (clockwise) rotated characters
O	O	ESC \$	Set absolute position
O	O	ESC ¥	Set relative position

T60/T80	T60P/T80P	Command	Command Name
<input type="radio"/>	<input type="radio"/>	GS k	Print bar code
<input type="radio"/>	<input type="radio"/>	GS W	Select horizontal size(magnification) of bar code
<input type="radio"/>	<input type="radio"/>	GS h	Select height of bar code
<input type="radio"/>	<input type="radio"/>	GS H	Select printing position of HRI characters
<input type="radio"/>	<input type="radio"/>	GS f	Select font for HRI characters
<input type="radio"/>	<input type="radio"/>	G S *	Define downloaded bit image
<input type="radio"/>	<input type="radio"/>	GS /	Print downloaded bit image
<input type="radio"/>	<input type="radio"/>	GS :	Set starting/ending position of macro definition
<input type="radio"/>	<input type="radio"/>	GS ^	Execute macro
<input type="radio"/>	<input type="radio"/>	E S C =	Select device
<input type="radio"/>	<input type="radio"/>	E S C a	Align positions