

OPERATION & MAINTENANCE MANUAL

Hydraulic Wrap Around Bender

MODEL # WTB-HRA 0/23

Revision History

Revision Status	Page	Summary of Changes	Date	Approved
0/23	All	Issued		

Manufactured by:

Triangle Engineering Inc.
Hanover, MA U.S.A.
U.S. Patent 3,906,784
Tel# 781-878-1500
www.trieng.com

Rev. 0
WTB-001

Table of Contents

Section 1

Operating and Parts Manual

Section 2

Assemblies and Descriptions

Section 3

Electrical and Hydraulic

Rev. 0
WTB-001

Section 1

Operating & Parts Manual

Page 4	Specifications
Page 5	Safety and Maintenance
Page 6	General Setup and Operating
Page 7	General Setup and Operating Continued
Page 8	Die Post and Jaw Installation
Page 10	Setup for A.P.I. 1104 / Locating Weld in Center of Bend
Page 11	Serial Number / Design Change History
Page 12	Condition of Sale and Warranty

Hydraulic Wrap Around Bender

This machine was designed and developed at Triangle Engineering, Hanover, MA USA. The primary function of the equipment is to bend a welded metal specimen into a 180 degree "U" shaped configuration, thereby subjecting the weld deposit to extreme tension, commonly referred to as a bend test.

After removal from a weld test coupon these straps or face, root, and side bend specimens are bent in the aforementioned shape very rapidly, with constant uniformity and consistent high quality. The full range of ferrous and nonferrous bend test requirements of A.S.M.E. Section IX and A.W.S. can be met with the adjustability of this device. The bend time cycle for a completed specimen, twenty to thirty seconds, is many times faster than known methods in use today. The unit is freestanding and does not require fastening at the floor line.

Specifications:

Electrical Motor:	1 H.P., 115V, 1PH, 60HZ, 13A, 1725 RPM
Hydraulic Pump:	1500 P.S.I. 1-1/2 G.P.M.
System Pressure:	Factory set at 1050 P.S.I.
Hydraulic Oil Reservoir:	Capacity 5 gallons
Vise Jaw:	Heat treated AISI S7
Die Post:	Heat treated AISI 4140
Spur Gear: (24 Teeth)	Heat treaded AISI 4140
Floor Space:	36" X 36"X 34" height
Weight:	380#

Rev. 0
WTB-001

Safety

Safety glasses must be worn at all times when operating this equipment. Keep your hands, tools or any foreign objects off the table and away from all moving parts during operation.

Maintenance

The WTB-HRA requires a minimum amount of maintenance, however, good housekeeping and a few routine checks will ensure years of uninterrupted service.

1. Wipe or brush clean the plate gear (#29) to remove any foreign material prior to activating the four-way valve (#31). Scratches and small grooves may occur but will not affect the operation of the bender. Proper cleaning will reduce the scoring.
2. Weekly: Check the reservoir oil level and add DTE 25 non-foaming hydraulic fluid (or equal) if necessary. A rapid or consistent loss of fluid would indicate a possible hydraulic system leak.
3. Weekly: Add grease to pivot post fitting (#28) and pressure roll (fitting not shown). See drawing TB13A (Page 12), generally 1 to 2 pumps of a grease gun is sufficient.
4. The two limit stops (#36) are to prevent accidental over travel of the lever arm, stopping the arm prior to hitting these stops will prevent unnecessary jarring and scoring.
5. Periodically, check the die post to ensure it is seated properly and tight.
6. Switch pump motor OFF when not in use. Prolonged operation in neutral position can cause heat build-up in the hydraulic system.

Danger!! Disconnect from the electrical power source and lockout prior to servicing unit.

General Setup

This tool should be connected to 120V-1PH 60HZ with circuit breaker capacity of 15 amperes. It is not necessary to bolt the machine to the floor. Depending on the location and proximity to other personnel in the immediate area, **safety guards may be required** by the purchaser, at their option.

The weld test bender is equipped with an adjustable vise providing greater flexibility and ease of operation. With simple vise adjustment and proper die post, this unit is capable of bending specimens around die post diameters from 3/8" to 3-3/8" without the need of changing jaws and/or adding shims.

Your machine is factory set for bending around a 1-1/2" diameter die post.

General Operating Instructions

1. Energize pumping system with on/off switch (41). Press valve handle (31) forward, position lever arm against limit stop (36). Turn off pumping system using on/off switch (41).
2. Install proper die post [Page 8 (API Page 9)].
3. Install proper jaw [Page 8 (API Page 9)].
4. Loosen the two vise clamp nuts (32L) located under the plate gear (29).
5. Carefully, slide the vise assembly (32) outbound to allow room for the die post.
6. Loosen the four bolts on the pressure roll assembly (5) and slide outbound.

General Operating Instructions Continued

7. Place the thicker end of the specimen into the vise using the 1-3/8" leveling cube to support outermost end of specimen while adjusting the opposite end in proximity to reference mark on fixed jaw. Hand tightened vise.
8. Slide the vise toward the die post. The **specimen should be within .03" of the die post.**
9. Tighten the two-vise clamp nut (32L).
10. Using a 1" open end wrench #35H tighten vise with moderate pressure to secure specimen.
11. Adjust pressure roll assembly(s) inboard to make contact with the specimen, **back off to allow 1/32" clearance** then tighten four Allen cap screws in holes closest to the die post to secure pressure roll assembly (5) to the lever arm.
12. Run adjustment screw (25) up to contact rear surface of pressure roll assembly (5).
13. Energize pumping system with on/off switch (41).
14. Unit is ready to commence 180-degree root bend. Pull on energy valve handle (31), lever arm assembly (13) will rotate clockwise wrapping specimen around the die post (4). Continue wrap around to complete 180-degree. Return lever arm assembly (13) to starting point, turn off pumping system using on/off switch (41), release vise pressure, open vise then remove the specimen.

Note 1: Open vise jaw only enough to remove specimen. Excessive opening will collide vise jaw (33,34) with pressure roll slide plate (8).

Note 2: Careful attention to the lever arm assembly (13) travel must be maintained by using small diameter die posts to prevent a collision with the vise. Some thin material bends may require additional bending by hand or vise to complete its 180-degree.

Die Post and Jaw Installation

Die Post Installation

1. Remove the overarm assembly (TB03).
2. Remove the die post by reaching under and to the center of the plate gear and loosen the clamp nut (26E) until it disengages from the die post. Lift the die post out from the top of the pivot post flange assembly (TB26).
3. Aligning the split pins (26B) at top of pivot post flange with corresponding holes on die post, place die post into the pivot post flange assembly (TB26). Reach under plate gear and thread the clamp assembly into the die post; tighten using 1" open ended wrench.

Note: The clamp knob is attached to the pivot post to prevent misplacement.

Vise Jaw Installation

Die post diameters less than 3/8" require a 1/2" stationary jaw TB33-500. Die post diameters 3/8" to 3-3/8" require a 3/4" stationary jaw TB33-750.

1. Remove the two socket head cap screws securing the stationary jaw B33-xxx. Install the required jaw giving special attention to the length of the jaw bolts. They should be flush with the clamping surface of the jaw to prevent marking of the specimen. Fasten the jaw securely.

Die Posts Less Than 1/4" (Segmented)

1. Remove the overarm (3) and existing die post (4).
2. Install segmented die post with flat face of segment parallel to stationary vise jaw (33).
3. Install the overarm; proceed with general operating instructions.

Die Posts 1/4" to less than 2" Diameter

1. Remove the overarm (3) and exiting die post (4).
2. Install the required die post.
3. Install the overarm; proceed with general operating instructions.

Die Posts 2" to 3-3/8" Diameter (Slip On)

1. Remove the overarm (3) and existing die post (4).
2. Install the 1-1/2" diameter die post.
3. Place the required die post sleeve over the 1-1/2" diameter die post.
4. Install the overarm; proceed with general operating instructions.

Die Post Part NO.TB04 XXX

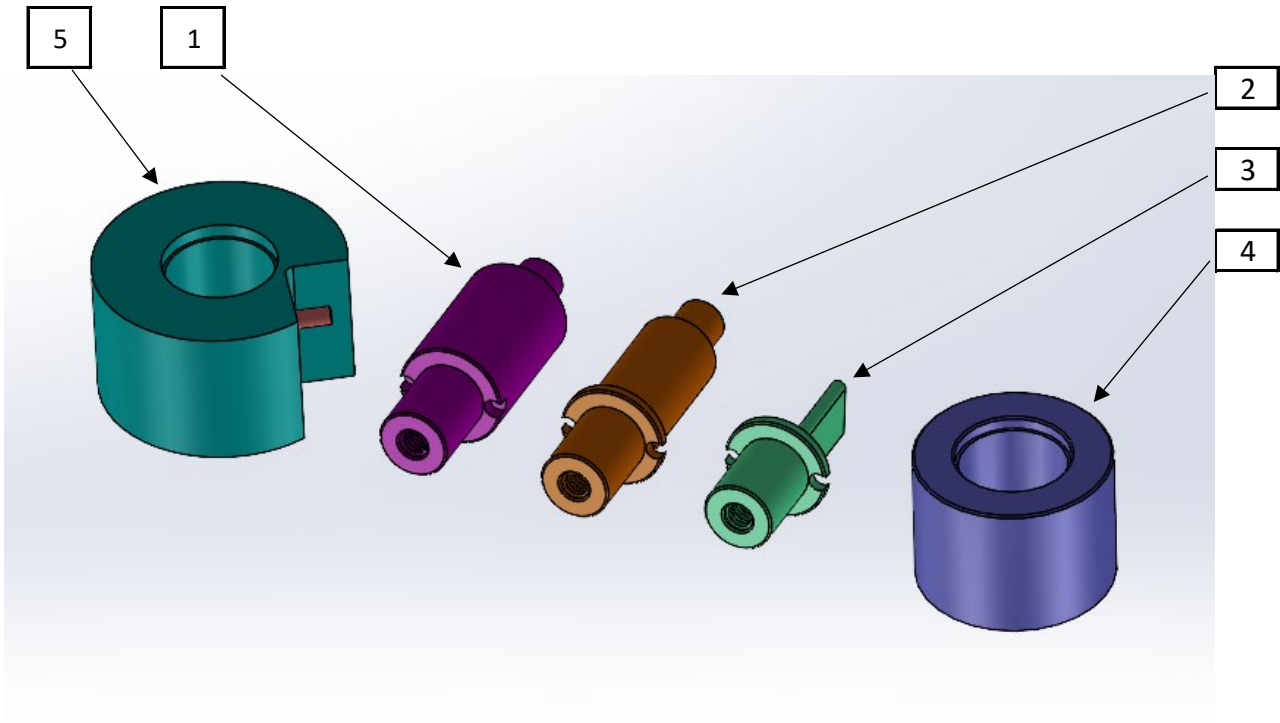

	<u>Part NO.</u>	<u>Description</u>	<u>QTY.</u>
1	TB-04-1.5	1-1/2" Die Post	1
2	TB04-	Less than 1 1/2" - 1/4"	1
3	TB04-	Segmented (Less than 1/4" - 1/8")	1
4	TB04-	Drop On (2"-3 3/8")	1
5	TB04-API	Drop On (3 1/2")	1

Set Up for A.P.I. 1104 Code

1. Remove stationary jaw (33), movable jaw (34) and overarm (3).
2. Install the 1-1/2" diameter die post (4).
3. Position the 3-1/2" drop on die post over the 1-1/2" die post (4) with the auxiliary support pin down. The cut away section should be oriented to provide nesting with the A.P.I. stationary jaw (33-API).
4. Install the overarm (3).
5. Install the A.P.I. movable jaw (34-API).
6. Install the A.P.I. stationary jaw (33-API).
7. Position the vise jaw equalizing screw (located on the stationary jaw (33-API) to compensate for the bend thickness.
8. Proceed with the general operating instructions.

Locating the Weld in the Center of the Bend

With a 3/8" thick bend using 1-1/2" diameter die post, measuring from the centerline of the weld back 4" and place a reference mark. Align this mark with the witness mark on the stationary jaw.

To locate the weld in the centerline of a bend specimen using die posts other than a 1-1/2" use the following to establish your reference mark.

$$\frac{(\text{Die post diameter} + \text{specimen thickness}) \times 3.14}{4}$$

Then add 2.5"

Understanding Your Serial Number

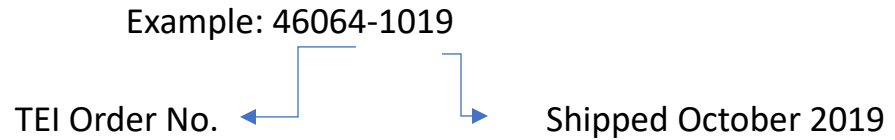

Design Change History

Over time we've updated equipment design for improved operation in the following areas;

- Pivot Post Flange & Die Post
- Pressure Roller Assembly
- Lever Arm & Overarm
- Vise Table Keys
- Cam Follower

If your machine was manufactured prior to 2000, ask about conversion assemblies available to upgrade your machine to current design!

Model WTB-HRA

Hydraulic Wrap Around Bender

Condition of Sale and Warranty

Triangle Engineering, Inc. will guarantee the original equipment as advertised and purchased under terms of the initial contract, for a period of ninety days (90) following delivery at your location, notwithstanding and provided that:

- A. The equipment has been operated and maintained without abuse and according to instructions and recommendations of Triangle Engineering, Inc.

This warranty covers the replacement of the defective parts and/or components, if after pre-approval and final examination by Triangle Engineering, Inc. they are returned prepaid. In no event shall this warranty exceed the original purchase price for said defective parts.

This equipment is new and unique to the field of Destructive Testing and is protected under U.S. Patent No. 3,906,784.

Section 2

Hydraulic Wrap Around Bender

Assemblies and Descriptions

Model# WTB-HRA

Page 13	Main Assembly	WTB-HRA
Page 14	"A" Tank & Leg Assembly	TB 44
Page 15	"B" Hydraulic Pump Assembly	TB 37
Page 16	"C" Table Gear Assembly	13A

Main Assembly Part NO. WTB-HRA

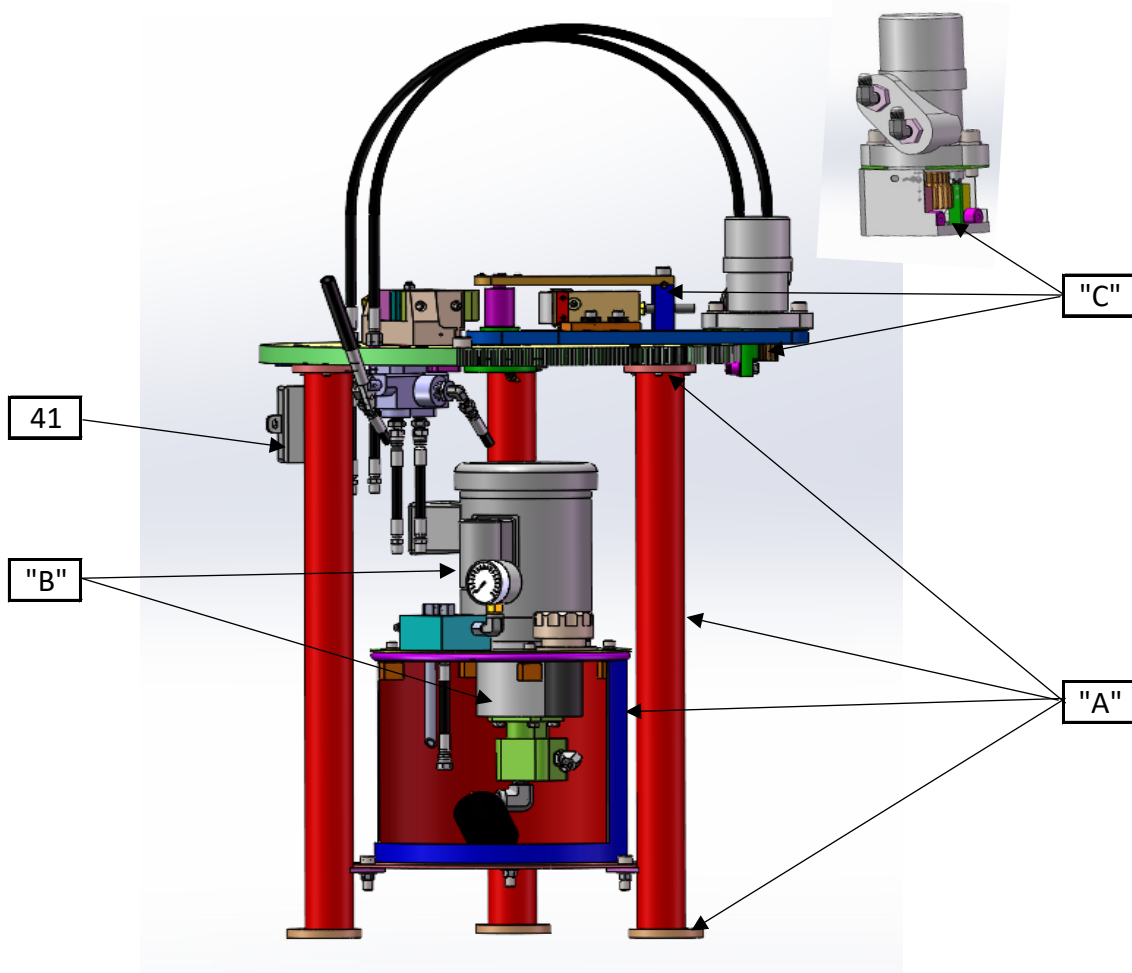

	<u>Part NO.</u>	<u>Description</u>
"A"	TB44	Tank and Leg Assembly (Reference Detail "A")
"B"	TB37	Hydraulic Pump Assembly (Reference Detail "B")
"C"	TB13A	Table Gear Assembly (Reference Detail "C")
41	TB41	On Off Switch

Detail "A" Tank & Leg Assembly Part No.TB 44

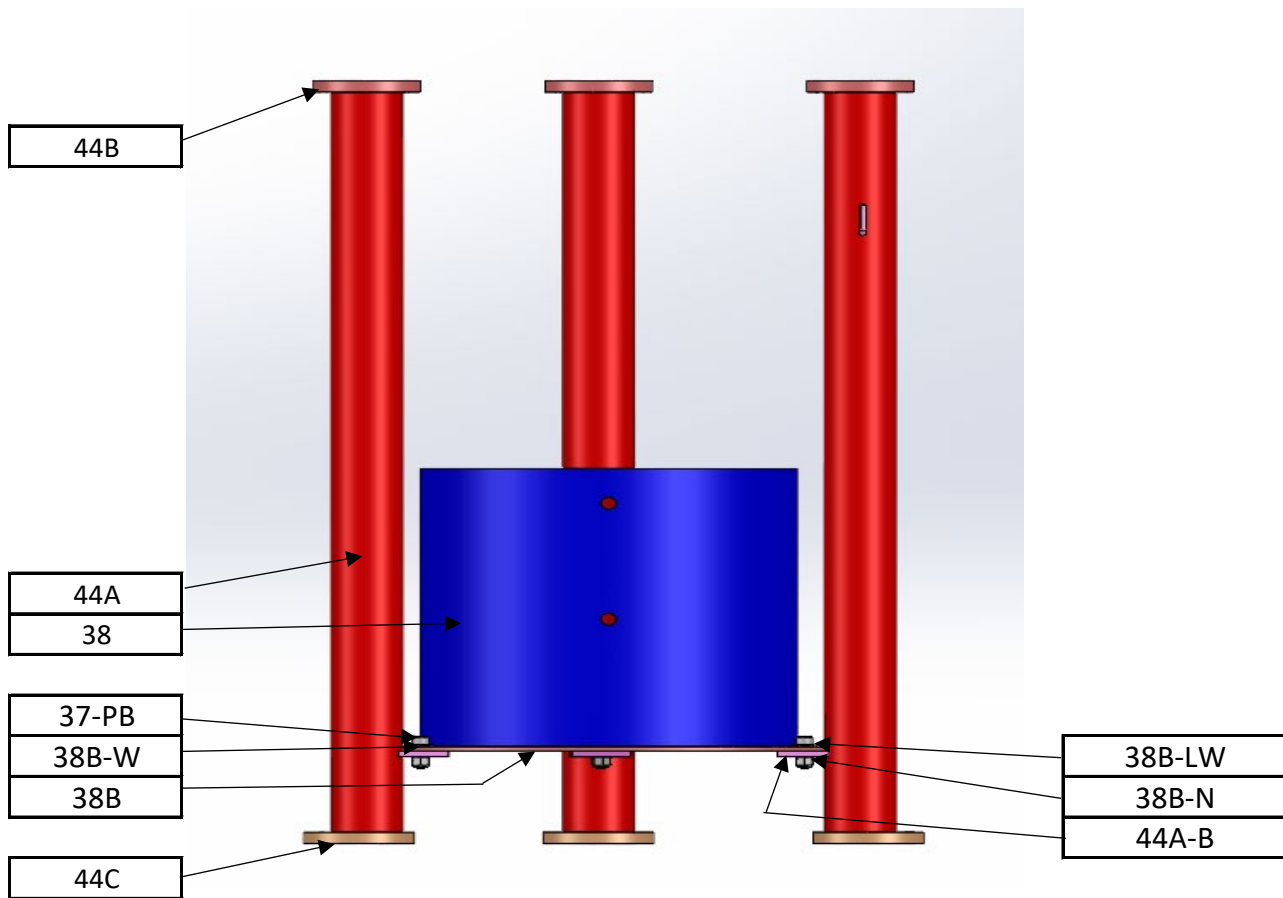

Part NO.

Description

44A	TB44A	Leg 2" sch 40 Pipe	3
44A-B	TB44A-B	Leg Bracket	3
38	TB38	Hydraulic Reservoir	1
37-PB	TB37-P-Bolt	3/8-16 SHCS	4
38B-W	TB38B-W	7/16 Washer	4
38B	TB38B	Reservoir Base	1
38B-LW	38B-LW	3/8-16 Base Nut	4
38B-N	38B-N	3/8 Lock Washer	4
44C	TB44C	Foot Disk	3
44B	TB44B	Top Disk	3

Rev.0
WTB-001

Detail "B" Hydraulic Pump Assembly Part No.TB 37

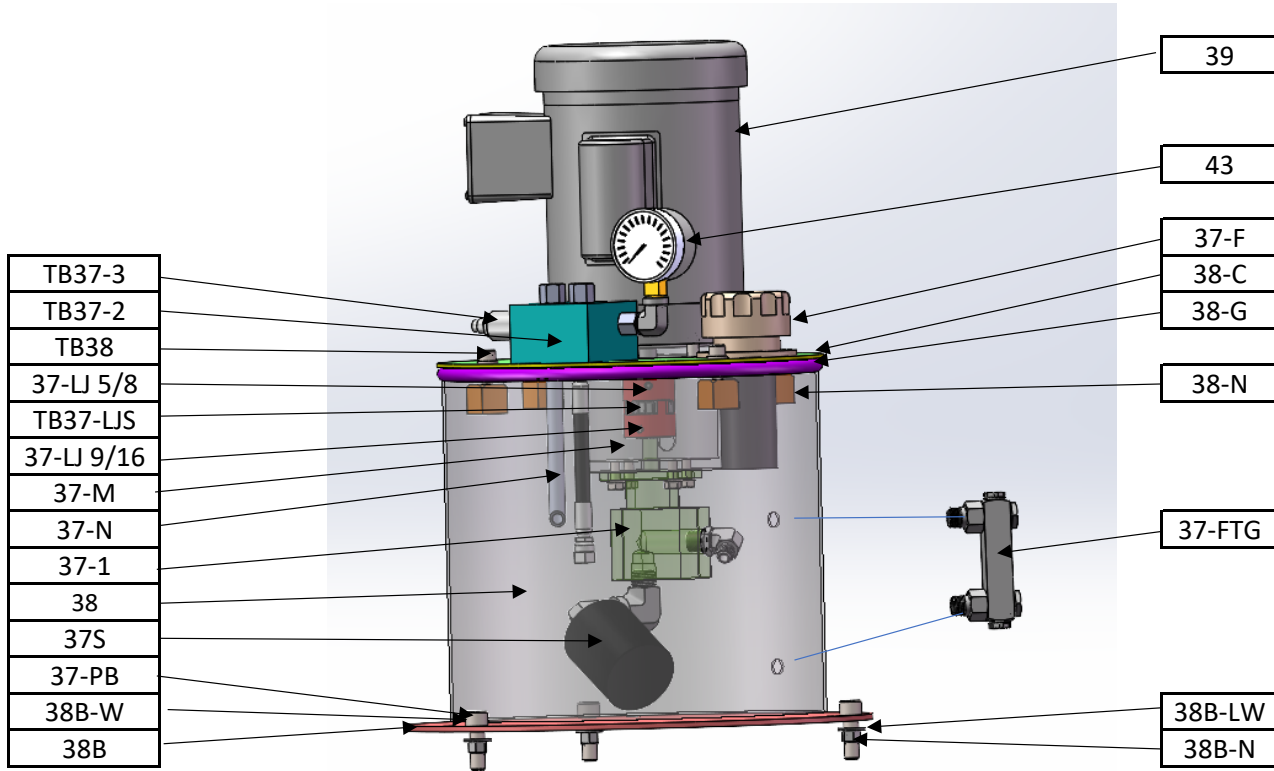

TB37-3
TB37-2
TB38
37-LJ 5/8
TB37-LJS
37-LJ 9/16
37-M
37-N
37-1
38
37S
37-PB
38B-W
38B

39
43
37-F
38-C
38-G
38-N
37-FTG
38B-LW
38B-N

Part NO.	Description	QTY.
39	TB39-60HZ Electric Motor	1
43	TB43-PG Pressure Gauge	1
37-F	TB37-FB Filter Breather	1
38-N	38-N Tank Nut	4
38-C	38-C Reservoir Tank Cover	1
38-G	38-G Tank Gasket	1
37-M	TB-37MPA Motor Pump Adapter	1
37-1	TB37-1 Hydraulic Pump Kit	1
37-FTG	TB37-FTG Fluid/ Temp Gauge	1
37-LJ-5/8	TB37-LJ5/8 Love Joy 5/8	1
37-LJ-9/16	TB37-LJ-9/16 Love Joy 6/16	1
TB37-LJS	L075OX/LO75 Coupling Insert	1
TB37-2	TB37-2 Valve Interface	1
TB37-3	TB37-3 Relief Valve	1
TB38	TB38-Bolt Tank Cover Bolt SHCS	4
37S	TB37-S Strainer	1
38	TB38 Hydraulic Reservoir	1
37-PB	TB37-P-Bolt 3/8-16 SHCS	4
38B	TB38B Reservoir Base	1
38B-W	TB38B-W 7/16 Washer	4
38B-LW	38B-LW 3/8-16 Base Nut	4
38B-N	38B-N 3/8 Lock Washer	4
37-N	37-N 1/4" SCH 40 Tank Return	1

Detail "C" Table Gear Assembly Part No. 13A

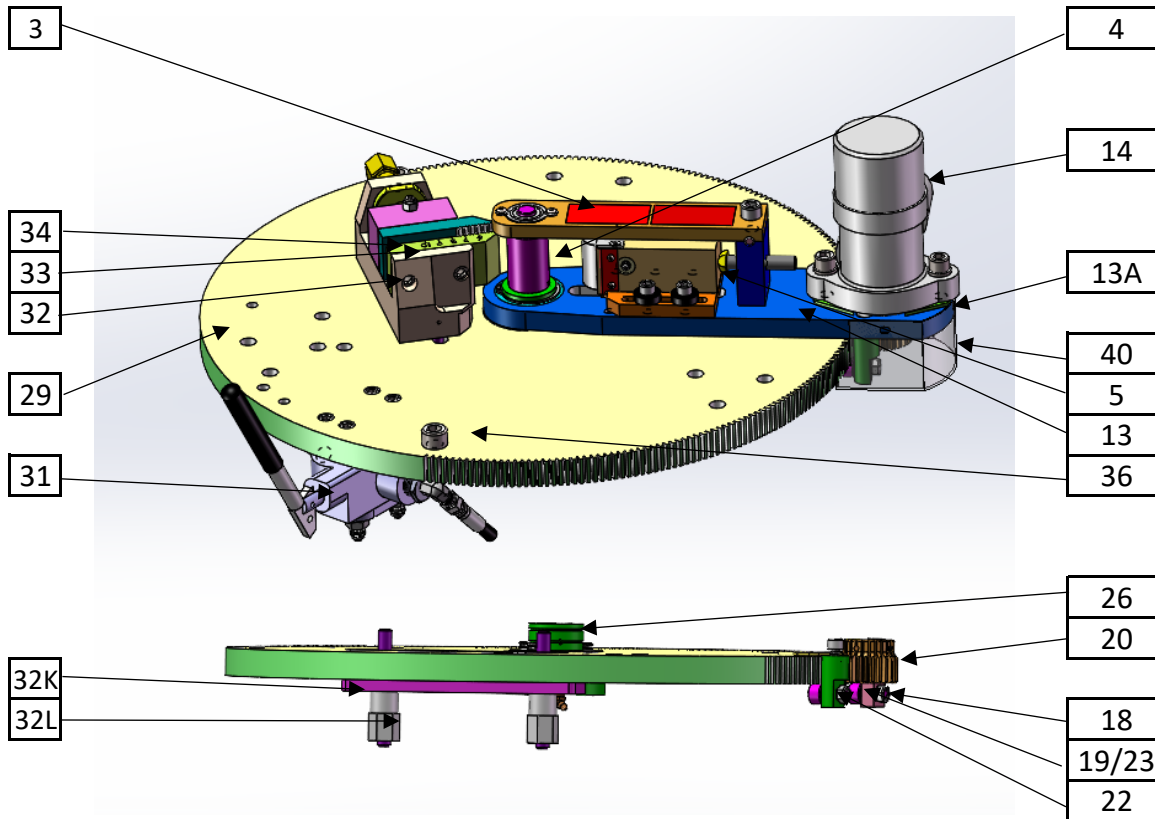

	<u>Part NO.</u>	<u>Description</u>	<u>QTY.</u>
4	TB04 XXX	Die Post	As Req.
5	TB05	Pressure Roller Assembly	1
13	TB13	Lever Arm Assembly	1
3	TB03	Over Arm Assembly	1
40	TB40	Gear Guard	1
14	TB14	Hydraulic Motor	1
32	TB32	Vise Assembly	1
34	TB34	Movable Jaw	1
33	TB33	Stationary Jaw	1
36	TB36	Limit Stops	2
31	TB31	Energy Valve	1
29	TB29	Plate gear	1
26	TB26	Pivot Post Flange	1
32K	TB-32-4	Vise Clamp Bar	1
32L	TB04K	Bender Vise Clamp Nut	2
20	TB20-CT	Drive Gear	1
18	TB18	3/8-24 Hex Nut	2
19/23	TB19/TB23	Cam Follower Post RH & LH	2
22	TB22	Cam Follower	2
13A	2B-13-SH	Torque Motor Shims	2

Rev.0
WTB-001

Section 3

Hydraulic Wrap Around Bender

Electrical and Hydraulic

Model# WTB-HTB/23

Page 18

Electrical and Hydraulic

Rev. 0
WTB-001

Electrical and Hydraulic

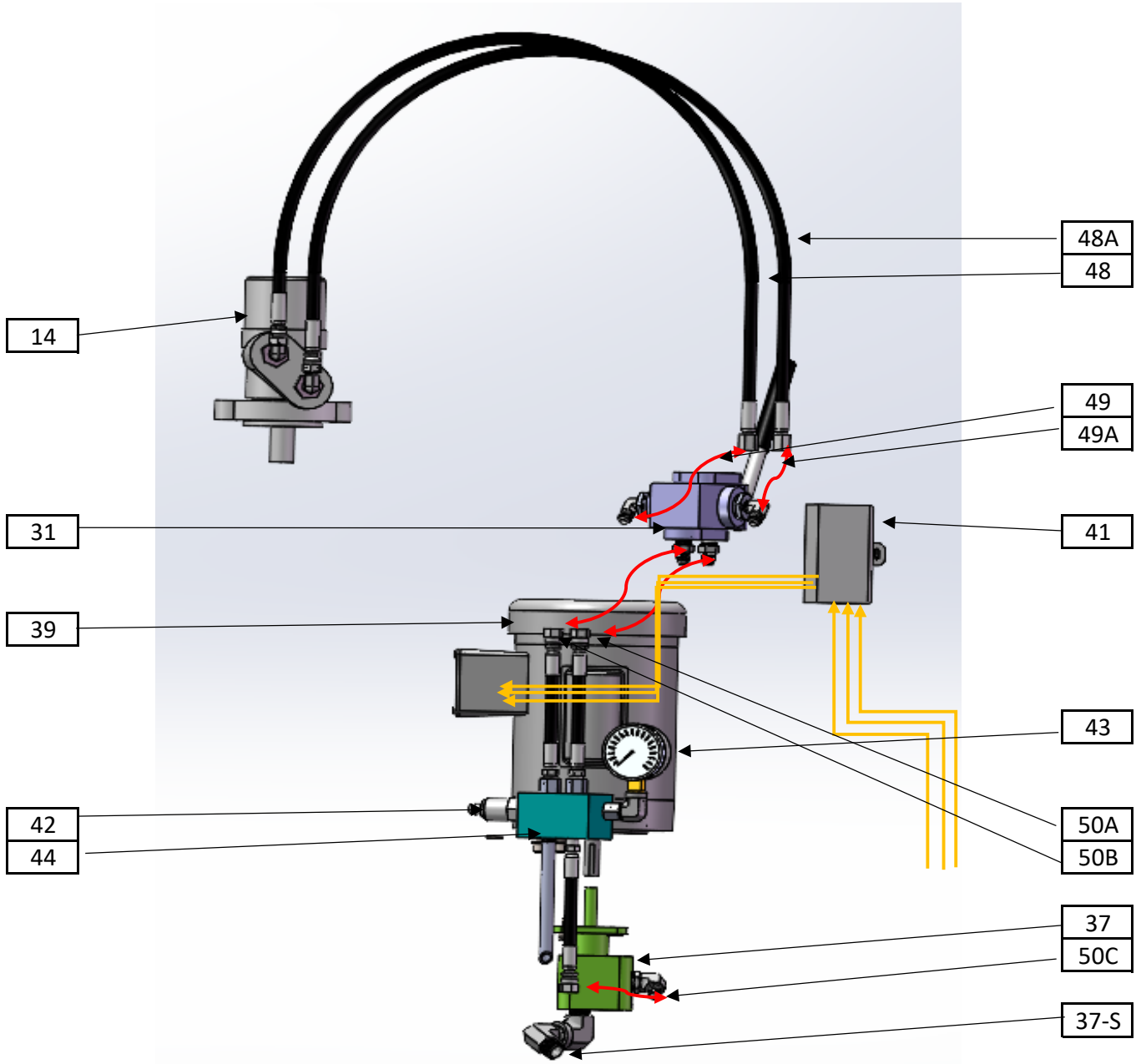

Part NO.	Description	QTY.
14	TB14 Hydraulic Motor	1
39	TB31 60HZ/HZ50 Electric Motor 1Hp 115 V	1
37	TB37 Hydraulic Pump	1
31	TB31 Energy Valve	1
42	TB42 Pressure Relief Valve	1
43	TB43 Pressure Gauge	1
44	TB37-2 Interface Valve	1
41	TB41 On-Off Switch	1
37-S	TB37-S Strainer (not shown)	1
48 & 48A	TB48 39" Hydraulic Hose	2
49 & 49A	TB49 21" Hydraulic Hose	1
50 A,B,C	TB50 16" Hydraulic Hose	3