

DS-LEDZRD-4X4, 5X5, 8X8



C-series



B-series

CLED-B12A/B15A  
CLED-C12A/C15A

# SEAMLESS **KITTED** Flat dvLED Mounting System

FOR SONY CRYSTAL B AND C SERIES DIRECT VIEW LED DISPLAYS

Peerless-AV's SEAMLESS Kitted Series Flat dvLED Mounting System is designed exclusively for the Sony Crystal B and C Series Direct View LED Displays, offering slim, space-saving, and aesthetically appealing designs for multiple configurations. With integrated cable management, easy-hang hardware, and a lightweight aluminum frame, integrators can quickly and easily build the perfect video wall. Peerless-AV® also offers start to finish support through the SEAMLESS dvLED Video Wall Integration Program. The Peerless-AV dvLED Solutions Team is there every step of the way to ensure every customer receives SEAMLESS product support and service.

# SONY

DS-LEDZRD-8X8 shown

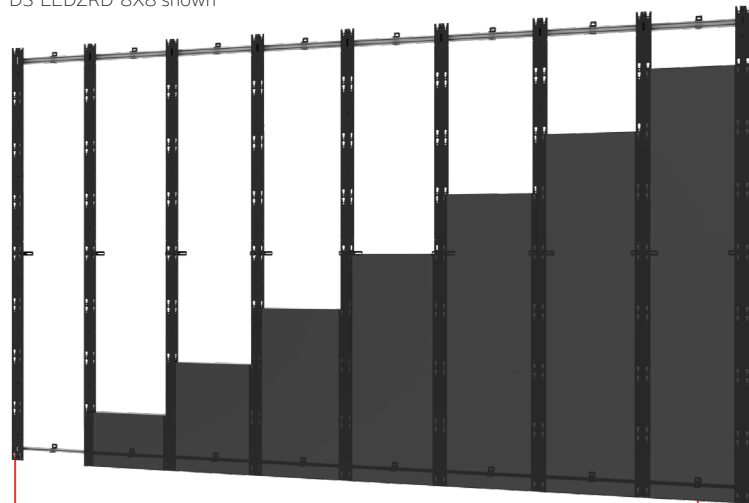

**HEIGHT ADJUSTMENT**  
Overcome installation irregularities to assure the dvLED pixels are aligned

**QUICK ASSEMBLY**  
Predetermined adaptor rail locations speed up assembly

**DEPTH ADJUSTMENT**  
The entire mount creates one flat plane, regardless of wall imperfections

- Lightweight aluminum frame is easy to install and minimizes the wall load
- Modular design offers unlimited video wall display configurations
- Tight tolerances and wall plate spacers ensure the cabinets are properly positioned



SEAMLESS by Peerless-AV® - dvLED Video Wall Integration Program offers:



**EXPERT  
ENGINEERING & DESIGN**



**CUSTOM  
PROJECT MANAGERS**

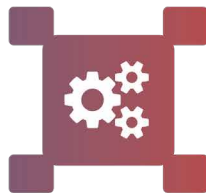

**FULL INSTALLATION  
SERVICES**

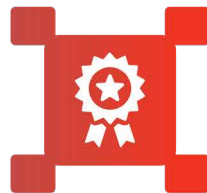

**SEAMLESS dvLED  
MOUNTING SYSTEMS**



**Visit Peerless-AV.com/SEAMLESS  
to get your project started!**

✉ info@peerless-av.com  
🌐 peerless-av.com

**peerless-AV®**  
Driving Technology Through Innovation

<b>DS-LEDZRD-4X4</b>	SEAMLESS Kitted Series Flat dvLED Mounting System for 4x4 Sony Crystal B and C Series Direct View LED Displays
<b>DS-LEDZRD-5X5</b>	SEAMLESS Kitted Series Flat dvLED Mounting System for 5x5 Sony Crystal B and C Series Direct View LED Displays
<b>DS-LEDZRD-8X8</b>	SEAMLESS Kitted Series Flat dvLED Mounting System for 8x8 Sony Crystal B and C Series Direct View LED Displays

**Product Specifications**

	DIMENSIONS (W x H x D)	PRODUCT WEIGHT	LOAD CAPACITY	FINISH	AVAILABLE COLORS
<b>DS-LEDZRD-4X4</b>	95.75" x 53.82" x 2.12"-2.87" (2,432 x 1,367 x 54-73mm)	57lb (26kg)	352lb (160kg)	Powder Coat & Clear Anodized Finish	Black & Silver
<b>DS-LEDZRD-5X5</b>	119.69" x 67.28" x 2.12"-2.87" (3,040 x 1,709 x 54-73mm)	73lb (33kg)	550lb (250kg)		
<b>DS-LEDZRD-8X8</b>	191.50" x 107.56" x 2.12"-2.87" (4,864 x 2,732 x 54-73mm)	138lb (63kg)	1,408lb (640kg)		

**Package Specifications**

	PACKAGE SIZE (W x H x D)	PACKAGE SHIP WEIGHT	PACKAGE UPC CODE	PACKAGE CONTENTS	UNITS IN PACKAGE
<b>DS-LEDZRD-4X4</b>	66.50" x 29.00" x 8.00" (1,689 x 737 x 203mm)	122lb (54kg)	735029345145	Wall Plate, Mounting Bracket, Spacer & Hardware	1
<b>DS-LEDZRD-5X5</b>	116.50" x 29.00" x 8.00" (2,959 x 737 x 203mm)	191lb (87kg)	735029345152		
<b>DS-LEDZRD-8X8</b>	116.50" x 29.00" x 8.00" (2,959 x 737 x 203mm)	252lb (115kg)	735029345169		

**Accessories**

**DS-LEDTK Models:** Universal Trim Kit for dvLED Video Walls 3.5" to 5.9" Deep

MODEL NO.	DIMENSION "A"	DIMENSION "B"
<b>DS-LEDZRD-4x4</b>	53.82" (1367mm)	95.75" (2432mm)
<b>DS-LEDZRD-5x5</b>	67.28" (1709mm)	119.69" (3040mm)
<b>DS-LEDZRD-8x8</b>	107.56" (2732mm)	191.50" (4864mm)

All dimensions = **inch** (mm)

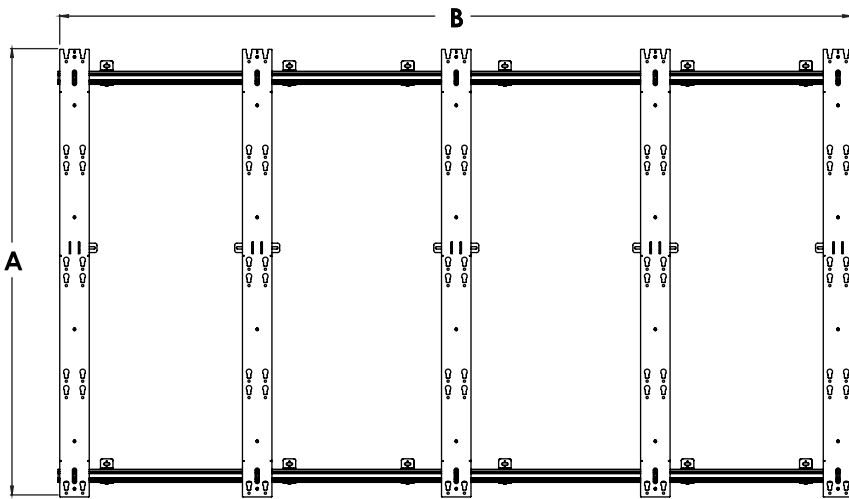

**FRONT VIEW**

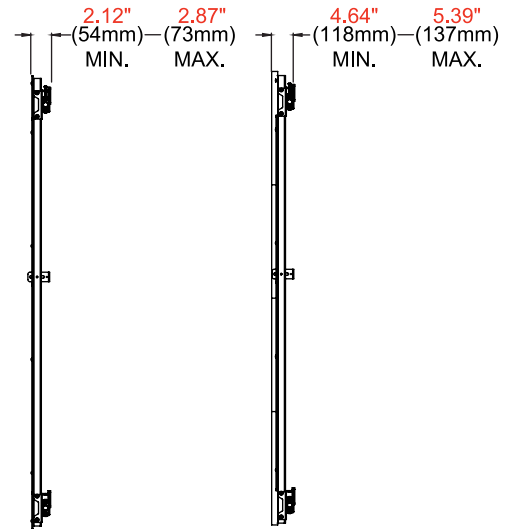

**SIDE VIEW**

**SIDE VIEW WITH DISPLAY**

**Architect Specifications**

The SEAMLESS Kitted Series Flat dvLED Mounting System shall be a Peerless-AV model DS-LEDZRD-4X4, 5X5, 8X8 and shall be located where indicated on the plans. Assembly and installation shall be done according to instructions provided by the manufacturer.

Visit [peerless-av.com](http://peerless-av.com) to see the complete line of AV solutions from Peerless-AV, including outdoor displays, kiosks, display mounts, projector mounts, carts/stands, and a full assortment of accessories.

**Peerless-AV**  
2300 White Oak Circle  
Aurora, IL 60502 USA  
  
**(800) 865-2112**  
**(630) 375-5100**  
**Fax: (800) 359-6500**

**Peerless-AV EMEA**  
Unit 3 Watford Interchange  
Colonial Way, Watford  
Herts, WD24 4WP  
United Kingdom  
**+44 (0) 1923 200100**  
**Fax: +44 (0) 1923 200101**

**Peerless-AV Latin America**  
Av. de las Industrias 413  
Parque Industrial Escobedo  
General Escobedo, N.L.,  
México, 66062  
**+52 (81) 8384-8300**  
**Fax: +52 (81) 8384-8360**

