

DS-LEDFAFE-4X4, 5X5, 6X6

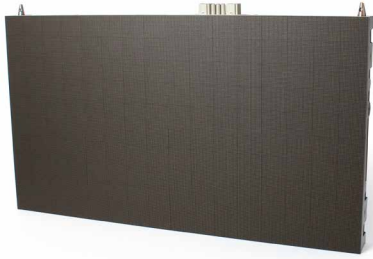

SEAMLESS **KITTED** Flat dvLED Mounting System

FOR SHARP/NEC FA AND FE SERIES DIRECT VIEW LED DISPLAYS

Peerless-AV's SEAMLESS Kitted Series Flat dvLED Mounting System is designed exclusively for the Sharp/NEC FA and FE Series Direct View LED Displays, offering slim, space-saving, and aesthetically appealing designs for multiple configurations. With integrated cable management, easy-hang hardware, and a lightweight aluminum frame, integrators can quickly and easily build the perfect video wall. Peerless-AV® also offers start to finish support through the SEAMLESS dvLED Video Wall Integration Program. The Peerless-AV dvLED Solutions Team is there every step of the way to ensure every customer receives SEAMLESS product support and service.

SHARP / NEC

DS-LEDFAFE-5X5 shown

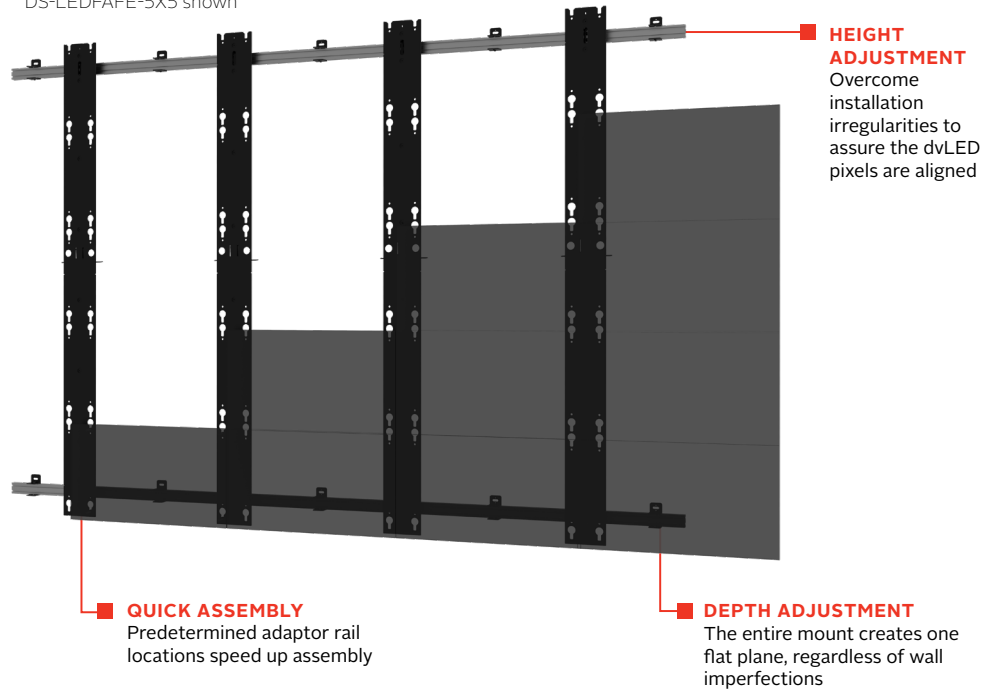

- Lightweight aluminum frame is easy to install and minimizes the wall load
- Modular design offers unlimited video wall display configurations
- Tight tolerances and wall plate spacers ensure the cabinets are properly positioned

TAA
COMPLIANT



SEAMLESS by Peerless-AV® - dvLED Video Wall Integration Program offers:



**EXPERT
ENGINEERING & DESIGN**



**CUSTOM
PROJECT MANAGERS**



**FULL INSTALLATION
SERVICES**

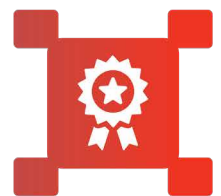

**SEAMLESS dvLED
MOUNTING SYSTEMS**

✉ info@peerless-av.com
🌐 peerless-av.com/SEAMLESS

peerless-AV®
Driving Technology Through Innovation

DS-LEDFAFE-4X4	SEAMLESS Kitted Series Flat dvLED Mounting System for 4x4 Sharp/NEC FA and FE Series Direct View LED Displays
DS-LEDFAFE-5X5	SEAMLESS Kitted Series Flat dvLED Mounting System for 5x5 Sharp/NEC FA and FE Series Direct View LED Displays
DS-LEDFAFE-6X6	SEAMLESS Kitted Series Flat dvLED Mounting System for 6x6 Sharp/NEC FA and FE Series Direct View LED Displays

Product Specifications

	DIMENSIONS (W x H x D)	PRODUCT WEIGHT	LOAD CAPACITY	FINISH	AVAILABLE COLORS
DS-LEDFAFE-4X4	71.81" x 53.46" x 2.19"-2.91" (1824 x 1358 x 56-74mm)	29lb (13kg)	310lb (141kg)	Powder Coat & Clear Anodized Finish	Black & Silver
DS-LEDFAFE-5X5	95.74" x 66.92" x 2.19"-2.91" (2432 x 1700 x 56-74mm)	46lb (22kg)	484lb (220kg)		
DS-LEDFAFE-6X6	119.68" x 80.39" x 2.19"-2.91" (3040 x 2040 x 56-74mm)	67lb (30kg)	697kg (317kg)		

Package Specifications

	PACKAGE SIZE (W x H x D)	PACKAGE SHIP WEIGHT	PACKAGE UPC CODE	PACKAGE CONTENTS	UNITS IN PACKAGE
DS-LEDFAFE-4X4	TBD	TBD	735029348177	Wall Plate, Mounting Brackets, Spacer & Hardware	1
DS-LEDFAFE-5X5			735029348184		
DS-LEDFAFE-6X6			735029348191		

Accessories **DS-LEDTK Models:** Universal Trim Kit for dvLED Video Walls 3.5" to 5.9" Deep

All dimensions = **inch** (mm)

MODEL NO.	DIMENSION "A"	DIMENSION "B"
DS-LEDFAFE-4X4	53.46" (1358mm)	71.81" (1824mm)
DS-LEDFAFE-5X5	66.92" (1700mm)	95.74" (2432mm)
DS-LEDFAFE-6X6	80.39" (2042mm)	119.68" (3040mm)

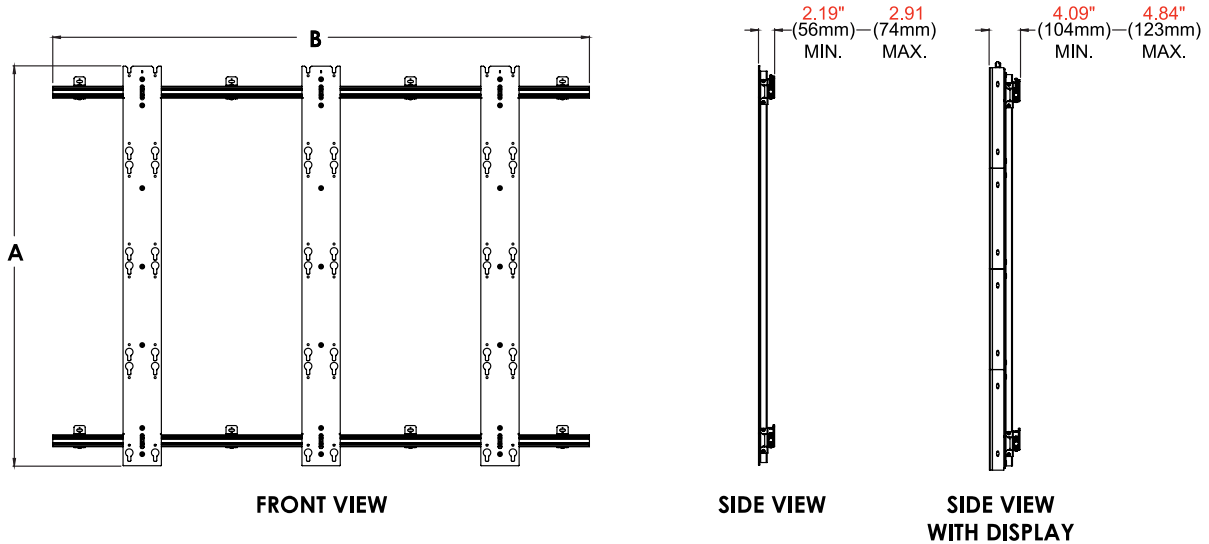

Architect Specifications

The SEAMLESS Kitted Series Flat dvLED Mounting System shall be a Peerless-AV model DS-LEDFAFE-4X4, 5X5, 6X6 and shall be located where indicated on the plans. Assembly and installation shall be done according to instructions provided by the manufacturer.

Visit peerless-av.com to see the complete line of AV solutions from Peerless-AV, including outdoor displays, kiosks, display mounts, projector mounts, carts/stands, and a full assortment of accessories.

Peerless-AV
 2300 White Oak Circle
 Aurora, IL 60502 USA
(800) 865-2112
(630) 375-5100
Fax: (800) 359-6500

Peerless-AV EMEA
 Unit 3 Watford Interchange
 Colonial Way, Watford
 Herts, WD24 4WP
 United Kingdom
+44 (0) 1923 200100
Fax: +44 (0) 1923 200101

Peerless-AV Latin America
 Av. de las Industrias 413
 Parque Industrial Escobedo
 General Escobedo, N.L.,
 México, 66062
+52 (81) 8384-8300
Fax: +52 (81) 8384-8360

