



# NOMAD 1300 RTT

**2**  
YEAR  
WARRANTY



Part Number: IRTT0023

[www.ironman4x4.com](http://www.ironman4x4.com)





# NOMAD 1300 RTT

## THE ROOFTOP ADVANTAGE

Rooftop tents are a great solution for both touring and extended camping trips. Rooftop camping comes with a range of benefits including an elevated abode away from animals, away from running surface water in heavy rain, and away from uneven ground and rocks in your hip or back. They also offer a simplified set-up and pack-up to ensure you spend more time doing the things you love.



## THE HARD SHELL ADVANTAGE

The benefits of a hard-shell rooftop tent really come into their own when looking at the convenience of set-up and pack-up as the hard shell cover itself forms a functional part of the tent's construction. Set up becomes a breeze with little to no structural poles to place; simply pop it open, roll out the ladder and you're literally a few steps away from a good night's sleep.



# NOMAD 1300 RTT

The **Nomad 1300** is the first of the new offerings from Ironman 4x4. The first thing to note of the **Nomad 1300** is its compact 'in-transit' profile. With a footprint of just 1600 x 1300mm and a net weight of just 68kg the **Nomad 1300** is perfectly coupled, in both size and weight, with dual cab ute canopies and many dual cab ute cabins as well as all size of 4x4 wagon and SUV.

While compact and light in transit, the **Nomad 1300** unfolds to reveal an impressive mattress space of 2050 x 1600mm. That's larger than your standard queen size bed!

SLEEPING QUARTERS	
<b>MATTRESS</b>	High density, non-deforming 40mm sponge mattress. 2050 x 1600mm: larger than a standard queen mattress.
<b>TENT FABRIC</b>	The main 280gsm ripstop poly-cotton tent provides great levels of breathability and improved temperature management, while the 420D Oxford polyester fly ensures a completely dry bed space.
<b>WINDOWS AND DOORS</b>	Integrated within the main tent is a generously sized entry as well as two side windows, each complemented with weather-shield awnings, ripstop solid covers and zipped insect-proof mesh.  On those perfect nights, a skylight window in the roof section is accessible for hours of stargazing from the comfort of your abode.

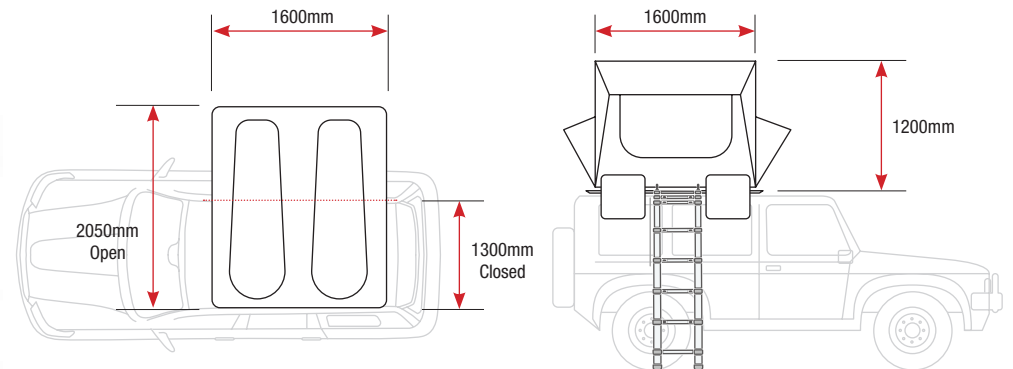

\* The ABS lid is formed with a tapered shape to assist with Aero dynamics and reduced drag. When installed the tent will open to the right hand side of the vehicle.





# NOMAD 1300 RTT

## LOCATING THE TENT ON YOUR VEHICLE



### Step 1:

Locate the tent on the roof rails, a minimum of 2 people are required.

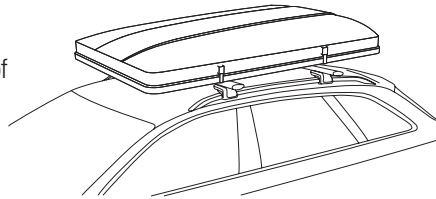

### Step 2:

Locate the bolts into the slide plates and insert into the mounting channel and position one either side of the roof rail.

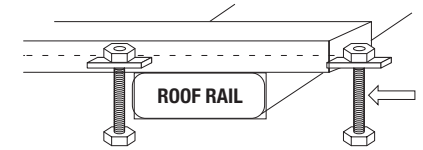

### Step 3:

Locate the mounting plate onto the bolts and secure with the Nylock nuts. Once all are assembled and the tent is in the correct position tighten all bolts.

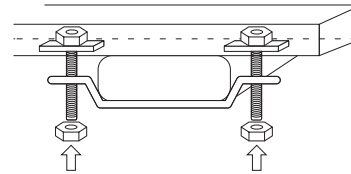

### Step 4:

Position the plastic end caps to the mounting channel.

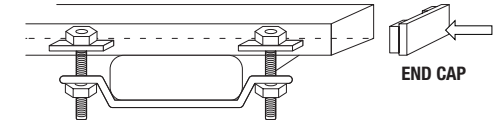

## THE SET-UP

Set-up is as simple as removing three nylon straps and pushing up the lightweight ABS cover which is assisted into position by two gas struts.

The integrated collapsible aluminium ladder is then used to lever forward the extending floor, which torsions the tent frame and tent into its final position.

Finally, 6 flexi-rods are installed into the surrounding window and door awnings.

A pair of weatherproof PVC boot pockets are included to hang on the exterior of the tent to keep your shoes close-by and your mattress clean.

## THE PACK DOWN

Pack-up is as simple and set-up. Simply remove the awning flexi-rods, attach the bungee strap (which conveniently pulls in the tent sides) fold away the floor extension and before pulling the clamshell top closed. A quick tuck-in, tighten the two straps and you're away.

As a bonus, light bedding can be pushed towards the back of the tent and stored inside the tent during transit.

### Step 1:

Extend the telescopic ladder and rotate the floor section to the horizontal position – Position and secure the ladder, ensuring it is stable and on an angle of approx 60 degrees.

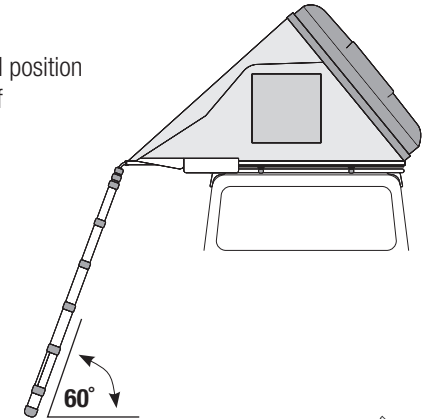
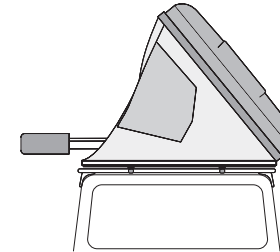
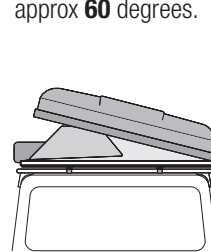

### Step 2:

Locate the Flexible Awning Stays for the Front and Side Window awnings and position in the allocated mounting holes in the base section and through the eyelets in the fabric.

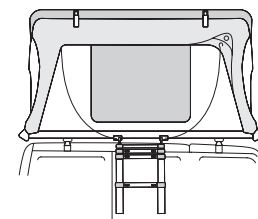

### Step 4:

In the event of rain, it is recommended that the flexible roof rail is inserted into the roof to form a peak in the fabric to stop the potential for water pooling on the roof.

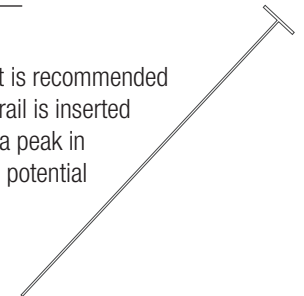



# NOMAD 1300 RTT

SPECIFICATIONS	NOMAD 1300 RTT
Gas Strut Assisted Hard Lid	Yes
Transit Dimensions (L x W x H mm)	1600 x 1300 x 320
Operational Dimensions (L x W x H mm)	1600 x 2050 x 1200
Lid Construction	ABS
Base Construction	ABS
Frame	Stainless steel with aluminium slats (base only)
Mattress Size (L x W x H mm)	2050 x 1600 x 60 (queen)
Mattress Construction	40mm non-deforming high density foam
Body Fabric	280gsm ripstop poly-cotton
Fly Fabric	420D Oxford polyester
Waterproof Testing (mm)	2000 water column
Window & Door Awnings	Yes
Weight	68kg
Max Capacity	300kg
Ladder Construction & Rating	Collapsible aluminium   150kg



## Features not to forget

If you're looking at the purchase of a rooftop tent, here are some features not to forget about the **Nomad 1300**

- Compact transit size and weight makes it perfect for installation on ute canopies and small wagons
- A mattress larger than your standard queen size bed means room to move
- The generous 1200mm internal height allows for plenty of room to sit up and allows a sensible use of the tent for rainy day refuge
- The skylight roof window allows for the ultimate stargazing experience



# COMPLEMENTARY ITEMS



## DELTAWING 270° XT-71

- 71 square feet (6.6m<sup>2</sup>) coverage
- 25/22mm aluminium tubular frame and support poles
- 280gsm Ripstop poly-cotton shelter with a PU2000 water rating



## DELTAWING 270° XTR-71

- 71 square feet (6.6m<sup>2</sup>) coverage
- 40 x 40mm C-Channel aluminium frame, 25/22mm tubular support poles
- 280gsm Ripstop poly-cotton shelter with a PU2000 water rating
- Can be operated unsupported in calm conditions



## DELTAWING 270° XTR-143

- Up to 143 square feet (13.3m<sup>2</sup>) coverage\*
- 40 x 40mm C-Channel aluminium frame, 25/22mm tubular support poles
- 280gsm Ripstop poly-cotton shelter with a PU2000 water rating
- Can be operated unsupported in calm conditions

\*Additional support poles and guy ropes are required and sold separately.



## KING HARD ARM CAMP CHAIR\*

- Comfortable quilted padded seat
- Lumbar support
- Can holder
- Storage pocket and mobile phone holder
- Dust and water resistant carry bag
- 200kg weight capacity

\*Available Jan 2022



## ALUMINIUM CAMP TABLE

- Height adjustable
- Full aluminium construction
- Compact and lightweight design
- Roll top design
- 600D Oxford carry bag
- Assembled - 835 x 482 x 415 / 600mm
- Packed - 585 x 205 x 125mm
- 25kg weight rating
- Weight: 3.6kg



## SOLAR MAT PANEL KIT

- A-Grade Monocrystalline Cell
- Shingle cell construction
- Charge regulator with 8 battery type function
- Plug-and-play with 50A Anderson plugs
- Built-in stands for setup flexibility
- Heavy duty carry bag included
- 3 year warranty

**120W**

1430 x 475 x 4mm (Open)

**200W**

2150 x 575 x 4mm (Open)



## CLUB LOUNGE QUAD FOLD CAMP CHAIR\*

- Comfortable quilted padded seat
- Storage pocket and mobile phone holder
- Dust and water resistant carry bag
- 150kg weight capacity

\*Available Jan 2022



## -5° SWAG BAG

- Large sizing: 235cm (L) x 1000mm (W)
- 300gsm cotton canvas
- - 5°C temperature comfort rating
- Dual layer 360gsm lofty hollow fibre with baffles
- Zip 2 bags together to make double sized sleeping bag
- Includes duffle carry bag





#### VICTORIA

2-8 Bessemer Drive,  
Dandenong Sth, VIC 3175

#### NEW SOUTH WALES

22 Yilen Close  
Beresfield, NSW 2322

#### QUEENSLAND

160 Robinson Road East,  
Geebung, QLD 4034

#### TOWNSVILLE

127 Crocodile Crescent  
Townsville, QLD 4818

#### WESTERN AUSTRALIA

Cnr Baile Rd and Craft St,  
Canning Vale, WA 6155

#### SOUTH AUSTRALIA

24 Cheltenham Parade,  
Woodville, SA 5011

#### INTERNATIONAL

##### IRONMAN 4X4 AMERICA

12905 SW Tualatin-Sherwood Rd, Ste 200.  
Sherwood, Oregon, 97140

##### IRONMAN 4X4 THAILAND

576 Soi Srinakarin 60, Srinakarin Road,  
Nongbon, Prawet, Bangkok,  
Thailand, 10250

##### IRONMAN 4X4 DUBAI

Plot No. 6131566, Street No. 7  
Ras Al Khor, Dubai, United Arab Emirates

##### IRONMAN 4X4 AFRICA PTY LTD

Ironman 4x4 Center  
1 Voortrekker Road Alberante ARC  
Alberton South Africa 1451

