

# INNOPLAST™

Innovative Polymer Products

INNOPLAST  
10120 GOTTSCHALK PKWY  
CHAGRIN FALLS, OH 44023  
TOLL FREE: 1-800-516-9287  
PHONE: (440) 543-8660  
FAX: (440) 543-8661  
www.innoplast.com

SELECT DESIRED HEIGHT:

36"

42"

48"

SELECT DESIRED POST COLOR:

ORANGE

YELLOW

SELECT DESIRED 3M REFLECTIVE TAPE:

WHITE

YELLOW

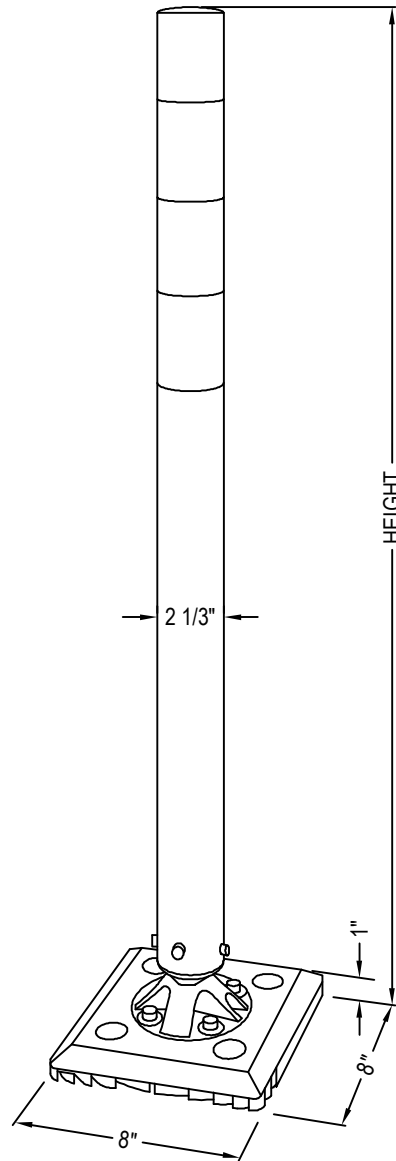

PERSPECTIVE

**SPECIFICATIONS:**

**MATERIAL:** PLASTIC/STEEL.

**ACCESSORIES:** SOLD SEPARATELY.

**CAP COLOR:** BLACK.

**WARRANTY:** 1 YEAR AGAINST MANUFACTURER DEFECTS.

**NOTES:**

1. INSTALLATION TO BE COMPLETED IN ACCORDANCE WITH MANUFACTURER'S SPECIFICATIONS.
2. DO NOT SCALE DRAWING.
3. THIS DRAWING IS INTENDED FOR USE BY ARCHITECTS, ENGINEERS, CONTRACTORS, CONSULTANTS AND DESIGN PROFESSIONALS FOR PLANNING PURPOSES ONLY. THIS DRAWING MAY NOT BE USED FOR CONSTRUCTION.
4. ALL INFORMATION CONTAINED HEREIN WAS CURRENT AT THE TIME OF DEVELOPMENT BUT MUST BE REVIEWED AND APPROVED BY THE PRODUCT MANUFACTURER TO BE CONSIDERED ACCURATE.
5. CONTRACTOR'S NOTE: FOR PRODUCT AND COMPANY INFORMATION VISIT [www.CADdetails.com/info](http://www.CADdetails.com/info) AND ENTER REFERENCE NUMBER 5132-028

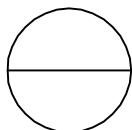

## FLEXIBLE BOLLARDS

MULTIPURPOSE POST