

INNOPLAST™

Innovative Polymer Products

INNOPLAST
 10120 GOTTSCHALK PKWY
 CHAGRIN FALLS, OH 44023
 TOLL FREE: 1-800-516-9287
 PHONE: (440) 543-8660
 FAX: (440) 543-8661
 www.innoplast.com

SELECT DESIRED SPEED BUMP:

- STANDARD - 4'
- STANDARD - 6'
- STANDARD - 9'
- DELUXE - 4'
- DELUXE - 6'

SELECT DESIRED SPEED BUMP OPTIONS:

- 8'
- 10'
- 12'

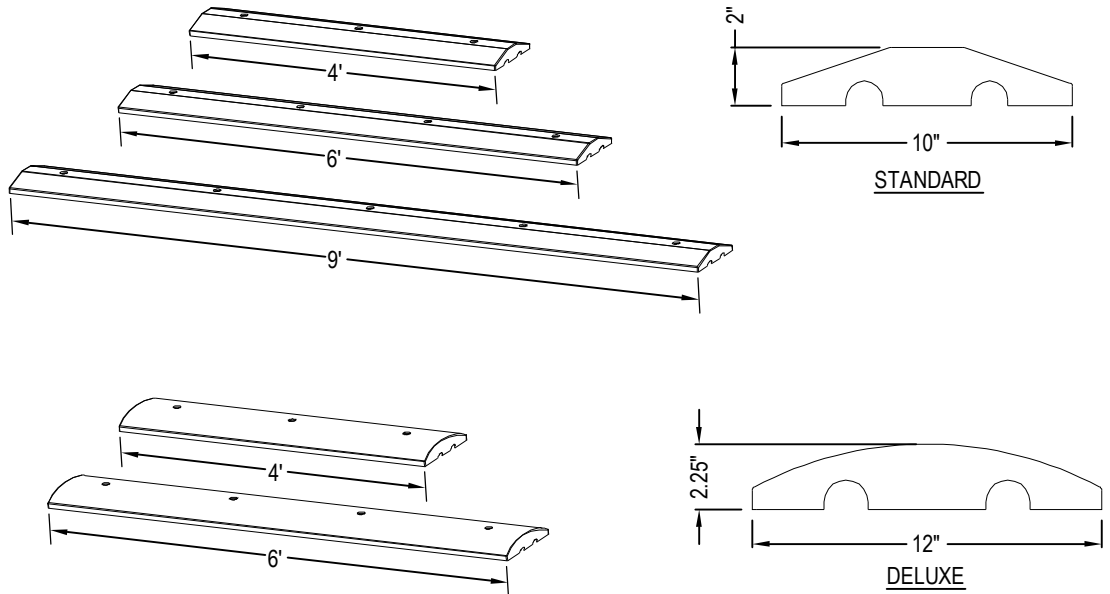

FEATURES:

LDPE-100% RECYCLED PLASTIC
 5 YEAR WARRANTY AGAINST MANUFACTURER DEFECTS
 MADE IN U.S.A.
 (2) 1" CHANNELS ON EACH

STANDARD COLORS:

YELLOW

PRODUCT	STYLE	LENGTH	HOLES	WEIGHT
SBC4	STANDARD	4'	3	14 lbs
SBC6	STANDARD	6'	4	23 lbs
SBC8	STANDARD	8'	4	31 lbs
SBC9	STANDARD	9'	5	36 lbs
SBC10	STANDARD	10'	5	43 lbs
SBC12	STANDARD	12'	6	52 lbs
SBCD4	DELUXE	4'	3	17 lbs
SBCD6	DELUXE	6'	4	36 lbs

ACCESSORIES:

LAG BOLTS (CONCRETE APPLICATION) OR SPIKES (ASPHALT APPLICATION) ARE INCLUDED
 END CAPS SOLD SEPARATELY.

NOTES:

1. INSTALLATION TO BE COMPLETED IN ACCORDANCE WITH MANUFACTURER'S SPECIFICATIONS.
2. DO NOT SCALE DRAWING.
3. THIS DRAWING IS INTENDED FOR USE BY ARCHITECTS, ENGINEERS, CONTRACTORS, CONSULTANTS AND DESIGN PROFESSIONALS FOR PLANNING PURPOSES ONLY. THIS DRAWING MAY NOT BE USED FOR CONSTRUCTION.
4. ALL INFORMATION CONTAINED HEREIN WAS CURRENT AT THE TIME OF DEVELOPMENT BUT MUST BE REVIEWED AND APPROVED BY THE PRODUCT MANUFACTURER TO BE CONSIDERED ACCURATE.
5. CONTRACTOR'S NOTE: FOR PRODUCT AND COMPANY INFORMATION VISIT www.CADdetails.com/info AND ENTER REFERENCE NUMBER 5132-014

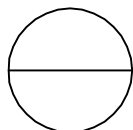

SPEED BUMPS

PLASTIC SPEED BUMPS