

# ROCKWELL®

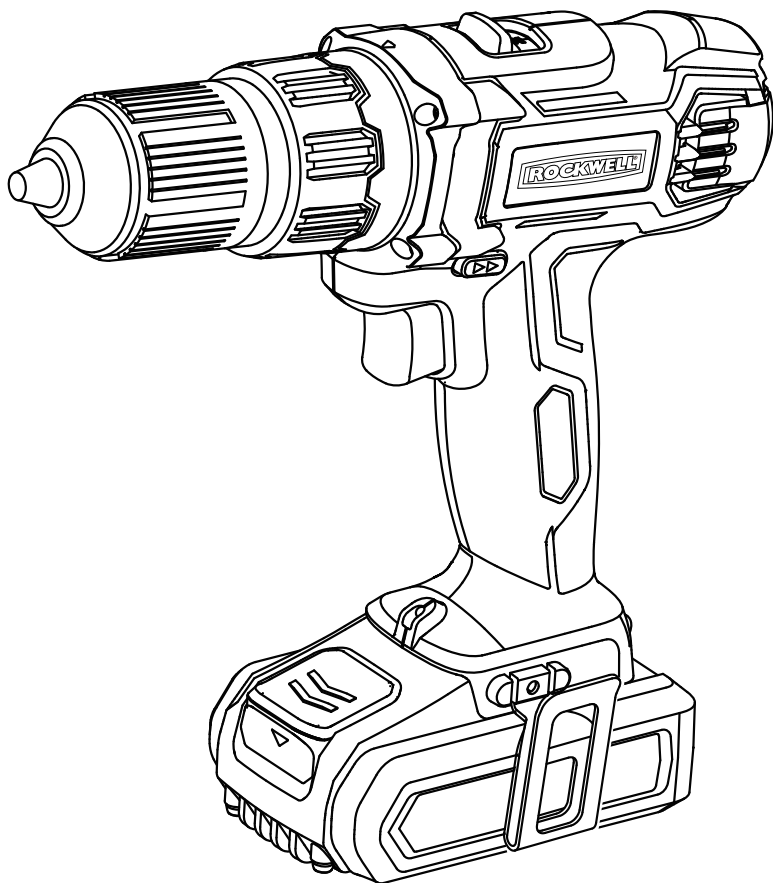

**RD2966**

**18V IMPACT DRILL**

**EN**



# RD2966

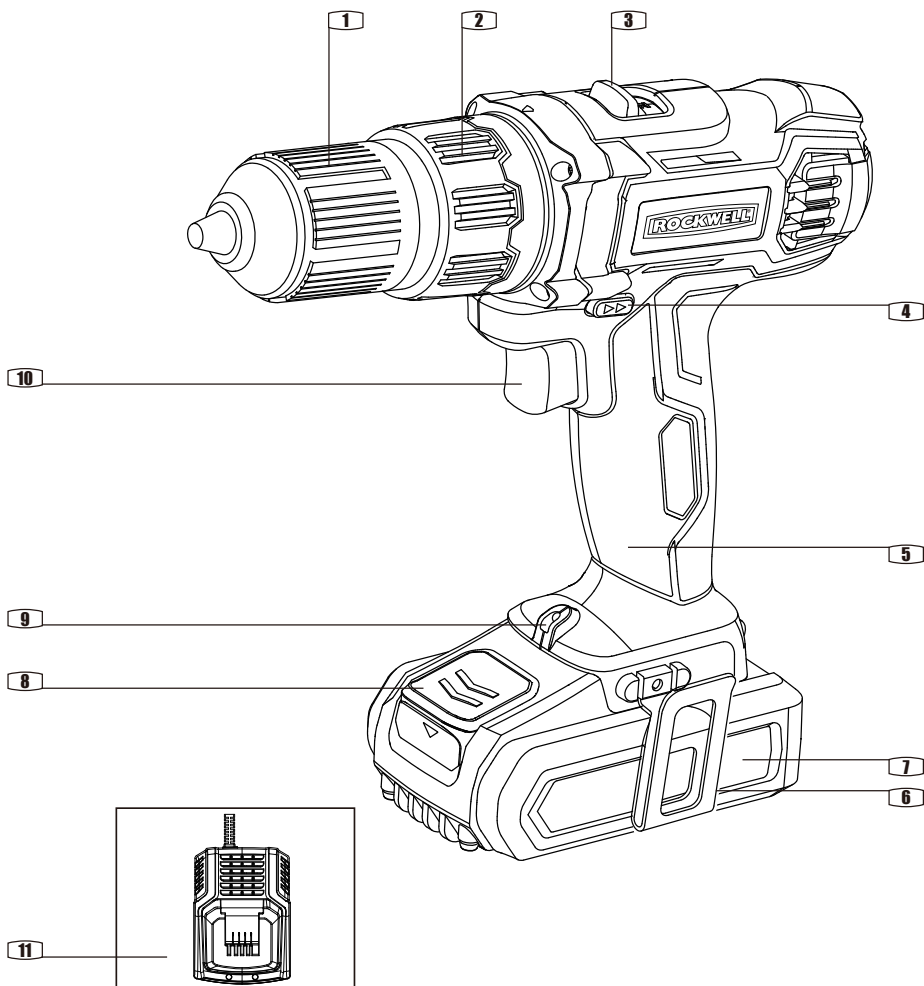

# RD2966

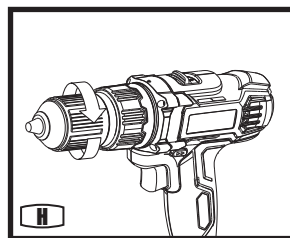
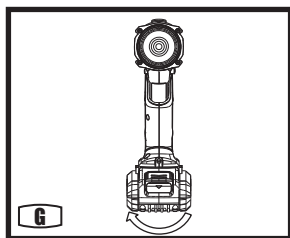
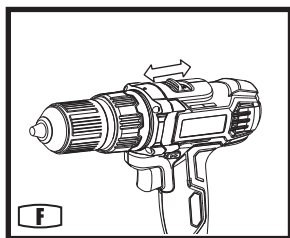
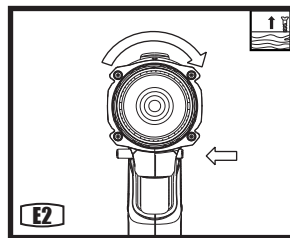
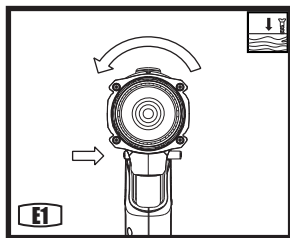
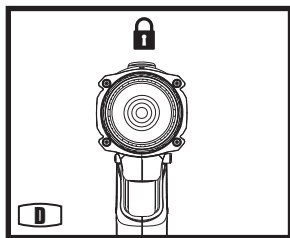
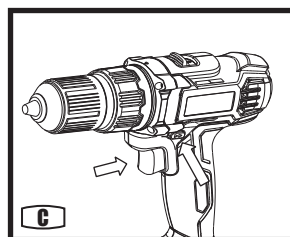
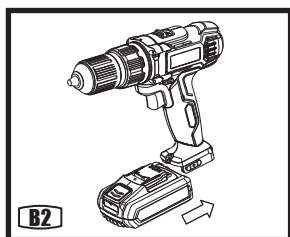
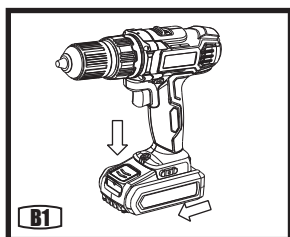
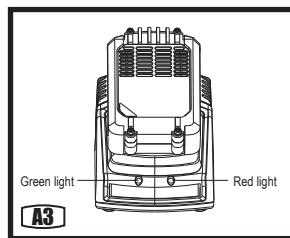
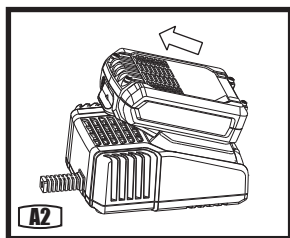
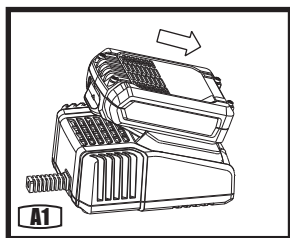

# RD2966

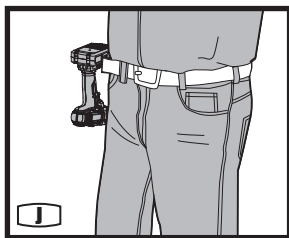
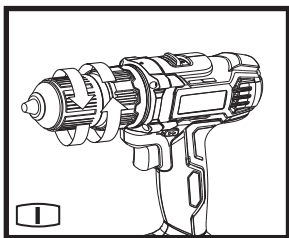

## COMPONENT LIST

- |    |                                  |
|----|----------------------------------|
| 1  | Keyless chuck                    |
| 2  | Torque adjustment ring           |
| 3  | Two-speed gear control           |
| 4  | Forward/Reverse rotation control |
| 5  | Soft grip handle                 |
| 6  | Belt clip                        |
| 7  | Battery pack                     |
| 8  | Battery pack release button      |
| 9  | Sight light                      |
| 10 | On/Off switch                    |
| 11 | Battery charger                  |

\* Not all the accessories illustrated or described are included in standard delivery.

## ACCESSORIES

Battery pack (RW9894) 1  
 Charger (RW9897) 1  
 Belt clip 1

We recommend that you purchase your accessories listed in the above list from the same store that sold you the tool. Refer to the accessory packaging for further details. Store personnel can assist you and offer advice.

## PRODUCT SAFETY GENERAL SAFETY WARNINGS

 **WARNING! Read all safety warnings and all instructions.** Failure to follow the warnings and instructions may result in electric shock, fire and/or serious injury.

**Save all warnings and instructions for future reference.**

The term “power tool” in the warnings refers to your mains-operated (corded) power tool or battery-operated (cordless) power tool.

### 1) WORK AREA SAFETY

- Keep work area clean and well lit.** Cluttered or dark areas invite accidents.
- Do not operate power tools in explosive atmospheres, such as in the presence of flammable liquids, gases or dust.** Power tools create sparks which may ignite the dust or fumes.
- Keep children and bystanders away while operating a power tool.** Distractions can cause

you to lose control.

## 2) ELECTRICAL SAFETY

- a) **Power tool plugs must match the outlet. Never modify the plug in any way. Do not use any adapter plugs with earthed (grounded) power tools.** Unmodified plugs and matching outlets will reduce risk of electric shock.
- b) **Avoid body contact with earthed or grounded surfaces, such as pipes, radiators, ranges and refrigerators.** There is an increased risk of electric shock if your body is earthed or grounded.
- c) **Do not expose power tools to rain or wet conditions.** Water entering a power tool will increase the risk of electric shock.
- d) **Do not abuse the cord. Never use the cord for carrying, pulling or unplugging the power tool. Keep cord away from heat, oil, sharp edges or moving parts.** Damaged or entangled cords increase the risk of electric shock.
- e) **When operating a power tool outdoors, use an extension cord suitable for outdoor use.** Use of a cord suitable for outdoor use reduces the risk of electric shock.
- f) **If operating a power tool in a damp location is unavoidable, use a residual current device (RCD) protected supply.** Use of an RCD reduces the risk of electric shock.

## 3) PERSONAL SAFETY

- a) **Stay alert, watch what you are doing and use common sense when operating a power tool. Do not use a power tool while you are tired or under the influence of drugs, alcohol or medication.** A moment of inattention while operating power tools may result in serious personal injury.
- b) **Use personal protective equipment. Always wear eye protection.** Protective equipment such as dust mask, non-skid safety shoes, hard hat, or hearing protection used for appropriate conditions will reduce personal injuries.
- c) **Prevent unintentional starting. Ensure the switch is in the off-position before connecting to power source and/or battery pack, picking up or carrying the tool.** Carrying power tools with your finger on the switch or energising power tools that have the switch on invites accidents.
- d) **Remove any adjusting key or wrench before turning the power tool on.** A wrench or a key left attached to a rotating part of the power tool may

result in personal injury.

- e) **Do not overreach. Keep proper footing and balance at all times.** This enables better control of the power tool in unexpected situations.
- f) **Dress properly. Do not wear loose clothing or jewellery. Keep your hair, clothing and gloves away from moving parts.** Loose clothes, jewellery or long hair can be caught in moving parts.
- g) **If devices are provided for the connection of dust extraction and collection facilities, ensure these are connected and properly used.** Use of these devices can reduce dust-related hazards.

## 4) POWER TOOL USE AND CARE

- a) **Do not force the power tool. Use the correct power tool for your application.** The correct power tool will do the job better and safer at the rate for which it was designed.
- b) **Do not use the power tool if the switch does not turn it on and off.** Any power tool that cannot be controlled with the switch is dangerous and must be repaired.
- c) **Disconnect the plug from the power source and/or the battery pack from the power tool before making any adjustments, changing accessories, or storing power tools.** Such preventive safety measures reduce the risk of starting the power tool accidentally.
- d) **Store idle power tools out of the reach of children and do not allow persons unfamiliar with the power tool or these instructions to operate the power tool.** Power tools are dangerous in the hands of untrained users.
- e) **Maintain power tools. Check for misalignment or binding of moving parts, breakage of parts and any other condition that may affect the power tool's operation. If damaged, have the power tool repaired before use.** Many accidents are caused by poorly maintained power tools.
- f) **Keep cutting tools sharp and clean.** Properly maintained cutting tools with sharp cutting edges are less likely to bind and are easier to control.
- g) **Use the power tool, accessories and tool bits etc. in accordance with these instructions, taking into account the working conditions and the work to be performed.** Use of the power tool for operations different from those intended could result in a hazardous situation.

**5) BATTERY TOOL USE AND CARE**

- a) **Recharge only with the charger specified by the manufacturer.** A charger that is suitable for one type of battery pack may create a risk of fire when used with another battery pack.
- b) **Use power tools only with specifically designated battery packs.** Use of any other battery packs may create a risk of injury and fire.
- c) **When battery pack is not in use, keep it away from other metal objects, like paper clips, coins, keys, nails, screws or other small metal objects, that can make a connection from one terminal to another. Shorting the battery terminals together may cause burns or a fire.**
- d) **Under abusive conditions, liquid may be ejected from the battery; avoid contact. If contact accidentally occurs, flush with water. If liquid contacts eyes, additionally seek medical help.** Liquid ejected from the battery may cause irritation or burns.

**6) SERVICE**

- a) **Have your power tool serviced by a qualified repair person using only identical replacement parts.** This will ensure that the safety of the power tool is maintained.

## ADDITIONAL SAFETY POINTS FOR YOUR BATTERY OPERATED DRILLS & IMPACT DRILL

- Wear ear protectors when impact drilling.** Exposure to noise can cause hearing loss.
- Use auxiliary handle(s), if supplied with the tool.** Loss of control can cause personal injury.
- Hold power tool by insulated gripping surfaces, when performing an operation where the cutting accessory may contact hidden wiring.** Cutting accessory contacting a "live" wire may make exposed metal parts of the power tool "live" and could give the operator an electric shock.

## GENERAL SAFETY WARNINGS FOR BATTERY CHARGER

**⚠ WARNING** Read all safety warnings and all instructions. Failure to follow the warnings and instructions may result in electric shock, fire and/or serious injury.

**Save all warnings and instructions for future reference.**

- This appliance is not intended for use by persons (including children) with reduced physical, sensory or mental capabilities, or lack of experience and knowledge, unless they have been given supervision or instruction concerning use of the appliance by a person responsible for their safety.
- Children should be supervised to ensure that they do not play with the appliance. If the supply cord is damaged, it must be replaced by the manufacturer, its service agent or similarly qualified persons in order to avoid a hazard.

## ADDITIONAL SAFETY INSTRUCTIONS FOR YOUR BATTERY CHARGER

- Before charging, read the instructions.
- For charge Li-ion battery pack only.
- Do not charge a leaking battery.
- Do not use chargers for works other than those for which they are designed.
- Before charging, ensure your charger is matching the local AC supply.
- The charging device must be protected from moisture.
- Do not use the charging device in the open.
- Do not short out the contacts of battery or charger.
- Respect the polarity "+/-" when charging.
- Do not open the unit and keep out of the reach of children.
- Do not charge the batteries of other manufactures or ill-suited models.
- Ensure that the connection between the battery charger and battery is correctly positioned and is not obstructed by foreign bodies.
- Keep battery charger's slots are free of foreign objects and protect against dirt and humidity. Store in a dry and frost-free place.



14. When charging batteries, ensure that the battery charger is in a well-ventilated area and away from inflammable materials. Batteries can get hot during charging. Do not overcharge any batteries. Ensure that batteries and chargers are not left unsupervised during charging.
15. Do not recharge non-rechargeable batteries, as they can overheat and break.
16. Longer life and better performance can be obtained if the battery pack is charged when the air temperature is between 18°C and 24°C. Do not charge the battery pack in air temperatures below 4.5 °C, or above 40.5°C. This is important as it can prevent serious damage to the battery pack.
17. Charge only battery pack of the same model provided by manufacturer and of models recommended by manufacturer.

## SAFETY WARNINGS FOR BATTERY PACK

- a) **Do not dismantle, open or shred cells or battery pack.**
- b) **Do not short-circuit a battery pack. Do not store battery packs haphazardly in a box or drawer where they may short-circuit each other or be short-circuited by conductive materials.** When battery pack is not in use, keep it away from other metal objects, like paper clips, coins, keys, nails, screws or other small metal objects, that can make a connection from one terminal to another. Shorting the battery terminals together may cause burns or a fire.
- c) **Do not expose battery pack to heat or fire. Avoid storage in direct sunlight.**
- d) **Do not subject battery pack to mechanical shock.**
- e) **In the event of battery leaking, do not allow the liquid to come into contact with the skin or eyes. If contact has been made, wash the affected area with copious amounts of water and seek medical advice.**
- f) **Seek medical advice immediately if a cell or battery pack has been swallowed.**
- g) **Keep battery pack clean and dry.**
- h) **Wipe the battery pack terminals with a clean dry cloth if they become dirty.**
- i) **Battery pack needs to be charged before use.**

**Always refer to this instruction and use the correct charging procedure.**

- j) **Do not maintain battery pack on charge when not in use.**
- k) **After extended periods of storage, it may be necessary to charge and discharge the battery pack several times to obtain maximum performance.**
- l) **Battery pack gives its best performance when it is operated at normal room temperature (20 °C ± 5 °C).**
- m) **When disposing of battery packs, keep battery packs of different electrochemical systems separate from each other.**
- n) **Recharge only with the charger specified by manufacturer. Do not use any charger other than that specifically provided for use with the equipment.** A charger that is suitable for one type of battery pack may create a risk of fire when used with another battery pack.
- o) **Do not use any battery pack which is not designed for use with the equipment.**
- p) **Keep battery pack out of the reach of children.**
- q) **Retain the original product literature for future reference.**
- r) **Remove the battery from the equipment when not in use.**
- s) **Dispose of properly.**

## SYMBOLS



To reduce the risk of injury, user must read instruction manual



Warning



Wear ear protection



Wear eye protection



Wear dust mask



RCM marking



Do not dispose of batteries, Return exhausted batteries to your local collection or recycling point.



Do not burn



Do not expose to rain or water



For indoor use only



Fuse



Positive terminal



Negative terminal

ABN: Australian Business Number. By this number, business information such as entity type, status, business location etc. can be found at website <http://abr.business.gov.au>.  
ABN of Positec Australia Pty Ltd is 14 101 682 357

## TECHNICAL DATA

Voltage	18V ---	
No load speed	0-400/0-1500/min	
Impact rate	0-6400/0-24000bpm	
Number of clutch positions	21+1+1	
Max torque	40N.m	
Chuck	13mm	
Charger protection class	□/II	
Charging time	1 hr	
Charger Input	100-240V~ 50/60Hz, 70W	
Charger Output	20V ---, 2.5A	
Battery capacity	2.0Ah Li-ion battery	
Max. drilling capacity	Steel	13mm
	Wood	35mm
Machine weight	1.4kg	

## OPERATION INSTRUCTIONS



**NOTE:** Before using the tool, read the instruction book carefully.

### Intended Use

The machine is intended for driving in and loosening screws as well as for drilling in wood, metal and plastic.

### CHARGING PROCEDURE

#### CHARGING YOUR BATTERY PACK (SEE FIG. A1, A2, A3)

Do not use any charger other than that specifically provided for use with the equipment.

If the battery pack is very hot you must remove your battery pack from the charger and allow time for the battery to cool down before recharging.

Please charge the battery to reach full before storage. If the tool will not be used for long periods of time, charge the battery every 3 months.

### CHARGING PROCEDURE

- 1) Plug the charger into an appropriate outlet. The light will be green.
- 2) Slide the battery pack into the charger, make sure the battery is in the correct charge position firmly.

the red light will turn on to indicate the charging process has started.

- 3) When charging is completed, the red light will turn off and the green light will turn on.
- 4) After fully charged, unplug the charger and remove the battery pack.



**NOTE:**

If the battery pack is locked in the charger, press the battery pack release button and remove it.

**WARNING:** When battery charge runs out after continuously use or exposure to direct sunlight or heat, allow time for the tool to cool down before re-charging to achieve the full charge.

**Charging indicator**

This charger is designed to detect some problems that can arise with battery packs. Indicator lights indicate problems (see table below). If this occurs, insert a new battery pack to determine if the charger is OK. If the new battery charges correctly, then the original pack is defective and should be returned to a service center or recycling service center. If the new battery pack displays the same problem as the original battery pack, have the charger tested at an authorized service center.

Light	Status	Status
Red on ● 	—————	Charging
Green on ● 	—————	Fully Charged

## OPERATION

**1. INSTALLING AND REMOVING THE BATTERY PACK**

**a) TO REMOVE THE BATTERY PACK (SEE FIG. B1)**

Depress the Battery Pack Release Button firmly first and then slide the Battery Pack out from your tool.

**b) TO INSTALL THE BATTERY PACK (SEE FIG. B2)**

Slide the fully charged Battery Pack onto the tool with sufficient force until it clicks into position.

**2. ON / OFF SWITCH (SEE FIG. C)**

Depress the On/Off switch to start and release it to stop your drill.

The on/off switch is fitted with a brake function which stops your chuck immediately when you quickly release the switch.

It is also a variable speed switch that delivers higher

speed and torque with increased trigger pressure. Speed is controlled by the amount of switch trigger depression.



**Warning: Do not operate for long periods at low speed because excess heat will be produced internally. When overload occurs, release the On/Off switch immediately to avoid the motor overheating.**

**3. SWITCH LOCK (SEE FIG. D)**

The switch trigger can be locked in the OFF position. This helps to reduce the possibility of accidental starting when not in use. To lock the switch trigger, place the rotation control in the center position.

**4. REVERSIBLE (SEE FIG. E1, E2)**

For drilling and screw driving use forward rotation marked “ << ” (lever is moved to the left). Only use reverse rotation marked “ >> ” (lever is moved to the right) to remove screws or release a jammed drill bit.



**Warning: Never change the direction of rotation when the chuck is rotating, wait until it has stopped!**

**5. TWO-SPEED GEAR CONTROL (SEE FIG. F)**

The drill has a two-speed gear control designed for drilling or driving at LO (mark is 1) or HI (mark is 2) speeds. A slide switch is located on top of the drill to select either LO or HI speed. When using the drill in the LO speed range, the speed will decrease and the drill will have greater power and torque. When using the drill in the HI speed range, the speed will increase and the drill will have less power and torque.

**Gear I**

Low speed range: for screwdriving or working with large drilling diameter

**Gear II**

High speed range: for working with small drilling diameter



**Warning: To prevent gear damage, always allow the chuck to come to a complete stop before changing the direction of rotation or the two-speed gear control. When overload occurs frequently on the high speed gear, switch to the low speed gear to avoid the motor overheating.**

**6. AUTOMATIC SPINDLE LOCK (SEE FIG. G)**

The automatic spindle lock allows you to use it as a regular screwdriver. You can give an extra twist to

firmly tighten a screw, loosen a very tight screw or continue working when the battery energy has expired. For manual screwdriver purposes, the chuck is automatically locked when the tool is off.

### 7. CHUCK ADJUSTMENT (SEE FIG. H)

To open the chuck jaws rotate the front section of the chuck. Insert the drill bit between the chuck jaws and rotate chuck in anticlockwise direction. Ensure the drill bit is in the center of the chuck jaws. Finally, firmly rotate the chuck in anticlockwise direction. Your drill bit is now clamped in the chuck.

### 8. TORQUE ADJUSTMENT (SEE FIG. I)



(Screw driving force of your drill driver)

The torque is adjusted by rotating the torque adjustment ring. The torque is greater when the torque adjustment ring is set on a higher setting. The torque is less when the torque adjustment ring is set on a lower setting.

When drilling in masonry and concrete choose the hammer position .

When drilling in wood, metal, plastic and screwdriver choose the drill position .

Make the setting as follows:

1 - 4	for driving small screws
5 - 9	for driving screws into soft material
10 - 14	for driving screws into soft and hard material
15 - 20	for driving screws into hard wood
21	for driving larger screws
	for heavy drilling
	for drilling in masonry and concrete

### 9. USING THE SIGHT LIGHT

To turn on the light, press the on/off switch and make sure the forward/reverse rotation control is on right/left position. When you release the on/off switch, the light will be off.

LED lighting increases visibility-great for dark or enclosed area.

### 10. BELT HOOK (SEE FIG. J)

Screw the Belt Hook on the tool with the screw provided in the plastic bag. The Belt Hook can be hooked on your belt or pocket, etc.

### 11. DRILLING

When drilling into a hard smooth surface, use a center punch to mark the desired hole location. This will prevent the drill bit from slipping off center as the hole is started.

Hold the tool firmly and place the tip of the bit at the point to be drilled.

Depress the switch trigger to start the tool.

Move the drill bit into the workpiece, applying only enough pressure to keep the bit cutting. Do not force or apply side pressure to elongate a hole.

If you want to activate the drill function (For drilling metal wood or plastic), turn the torque adjustment ring on the drill position.

If you want to activate the impact function(For masonry or concrete), turn the torque adjustment ring on the hammer position.

 **Tungsten carbide drill bits should always be used for concrete and masonry. When drilling in metal, only use HSS drill bits in good condition. Always use a magnetic bit holder (not included) when using short screwdriver bits. When screw-driving, apply a small quantity of liquid soap or similar to the screw threads to ease insertion.**

### 12. OVERLOAD PROTECTION

When overloaded, the motor comes to a stop. Relieve the load on the machine immediately and release the on/off switch. Then you can restart the tool soon.

### 13. TEMPERATURE DEPENDENT OVERLOAD PROTECTION

When using as intended for the power tool cannot be subject to overload. When the load is too high or the allowable battery temperature is too hot, the electronic control switches off the power tool until the temperature is in the optimum temperature range again.

### 14. PROTECTION AGAINST DEEP DISCHARGING

The Li-ion battery is protected against deep discharging by the "Discharging Protection System". When the battery is empty, the machine is switched off by means of a protective circuit: The inserted tool no longer rotates.

**15. DISPOSAL OF AN EXHAUSTED BATTERY PACK**



To preserve natural resources, please recycle or dispose of the battery pack properly. This battery pack contains Lithium batteries.

Consult your local waste authority for information regarding available recycling and/or disposal options. Discharge your battery pack by operating your drill, then remove the battery pack from the drill housing and cover the battery pack connections with heavy-duty adhesive tape to prevent short circuit and energy discharge. Do not attempt to open or remove any of the components.

**PROBLEM SOLUTION****1. WHY DOES THE DRILL NOT TURN ON WHEN YOU PRESS THE SWITCH?**

The forward/reverse rotation control, which is on top of the trigger, is positioned in the lock function. Unlock the forward/reverse rotation control by putting it into the required rotation position. Push the trigger and the drill will start to rotate.

**2. THE DRILL STOPS BEFORE THE SCREW IS COMPLETELY TIGHTENED. WHY?**

Verify the torque position of the torque adjusting ring, you can find the torque-adjusting ring between the chuck and the drill body. Position 1 is the lowest torque (screw driving force) and position 21 is the highest torque (screw driving force). Position  is for drill operation. Position  is for hammer drill operation. Regulate the torque adjusting ring to a higher position to reach the best result.

**3. I CANNOT FIT THE BATTERY INTO THE BATTERY CHARGER. WHY?**

The battery can be inserted into the charger only in one direction. Turn the battery around until it can be inserted into the slot.

**4. REASONS FOR DIFFERENT BATTERY PACK WORKING TIMES**

Charging time problems, as above, and having not used a battery pack for a prolonged time will reduce the battery pack working time. This can be corrected after several charge and discharge operations by charging & working with your drill. Heavy working conditions such as large screws into hard wood will use up the battery pack energy faster than lighter

working conditions. Do not re-charge your battery pack below 0 °C and above 45 °C as this will affect performance.

**MAINTENANCE**

**Remove the battery pack from the tool before carrying out any adjustment, servicing or maintenance.**

Your tool requires no additional lubrication or maintenance.

There are no user serviceable parts in your power tool. Never use water or chemical cleaners to clean your power tool. Wipe clean with a dry cloth. Always store your power tool in a dry place. Keep the motor ventilation slots clean. Keep all working controls free of dust. Occasionally you may see sparks through the ventilation slots. This is normal and will not damage your power tool.







**POSITEC AUSTRALIA PTY LTD**  
**ABN 14 101 682 357**

**MADE IN PRC**