

ROCKWELL®

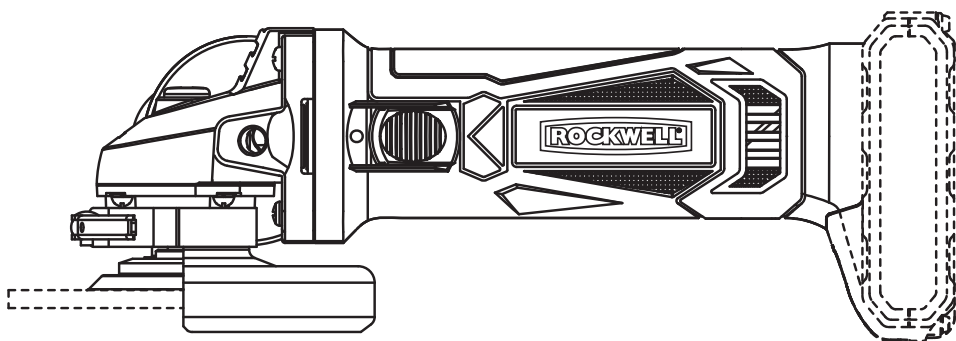

RD2923.9

CORDLESS ANGLE GRINDER

EN

RD2923.9

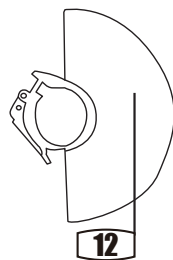
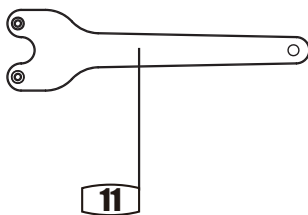
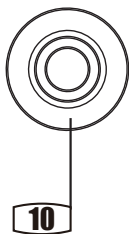
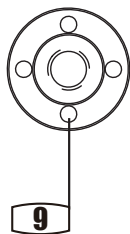
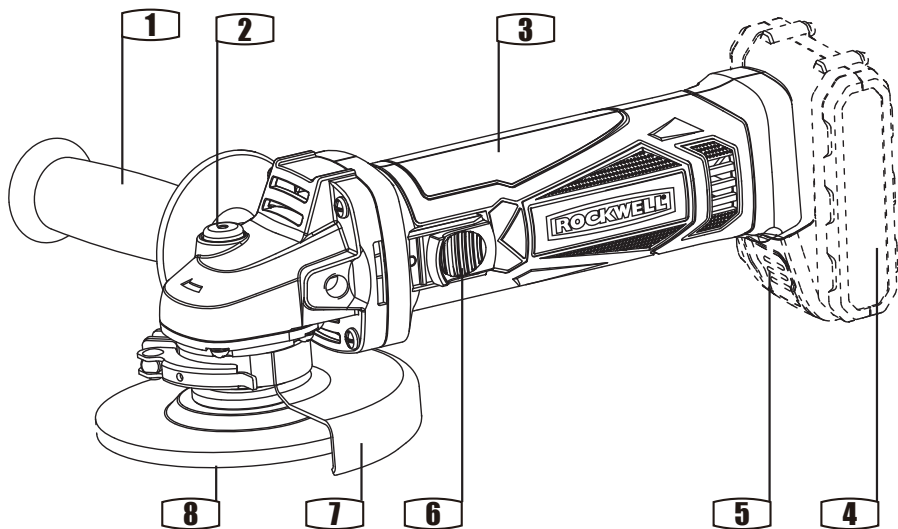

RD2923.9

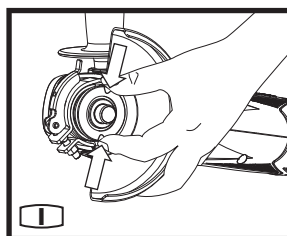
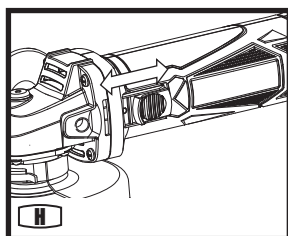
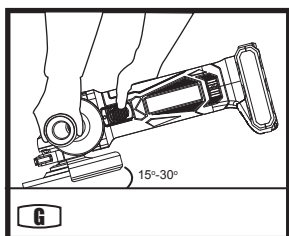
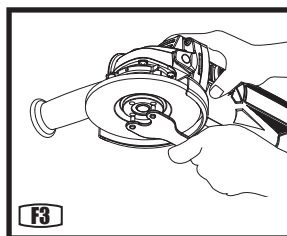
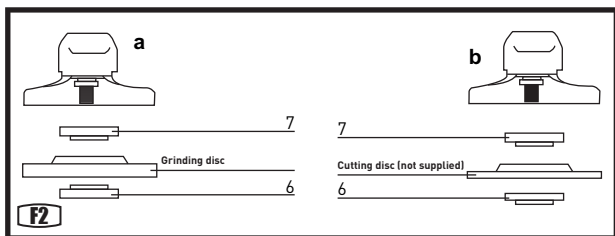
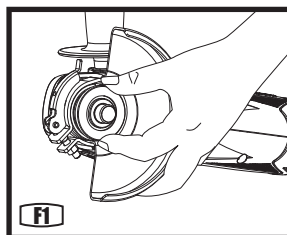
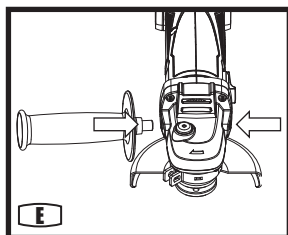
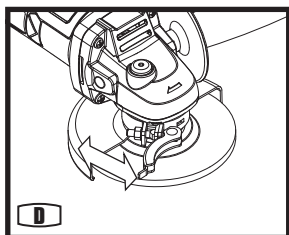
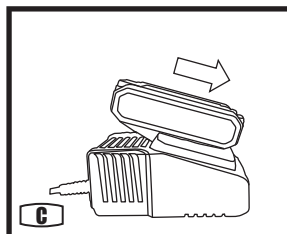
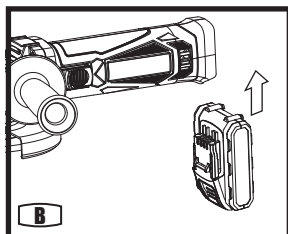
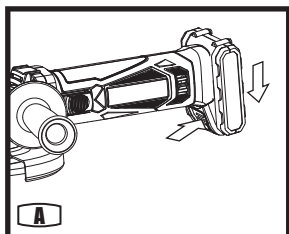

RD2923.9

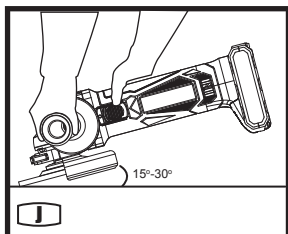

COMPONENT LIST

- 1 Auxiliary handle

- 2 Spindle lock button

- 3 Soft grip handle

- 4 Battery pack *(not included)

- 5 Battery release button *(not included)

- 6 On/Off switch

- 7 Wheel guard for grinding

- 8 Grinding wheel* (not included)

- 9 Outer flange

- 10 Inner flange

- 11 Spanner

- 12 Wheel guard for cutting *(not included)

* Not all the accessories illustrated or described are included in standard delivery.

ACCESSORIES

Auxiliary handle	1
Spanner	1
Quick guard for grinding	1

We recommend that you purchase your accessories listed in the above list from the same store that sold you the tool. Refer to the accessory packaging for further details. Store personnel can assist you and offer advice.

PRODUCT SAFETY GENERAL SAFETY WARNINGS

 **WARNING! Read all safety warnings and all instructions.** Failure to follow the warnings and instructions may result in electric shock, fire and/or serious injury.

Save all warnings and instructions for future reference.

The term “power tool” in the warnings refers to your mains-operated (corded) power tool or battery-operated (cordless) power tool.

1) WORK AREA SAFETY

- a) **Keep work area clean and well lit.** Cluttered or dark areas invite accidents.
- b) **Do not operate power tools in explosive atmospheres, such as in the presence of flammable liquids, gases or dust.** Power tools create sparks which may ignite the dust or fumes.
- c) **Keep children and bystanders away while operating a power tool.** Distractions can cause you to lose control.

2) ELECTRICAL SAFETY

- a) **Power tool plugs must match the outlet. Never modify the plug in any way. Do not use any adapter plugs with earthed (grounded) power tools.** Unmodified plugs and matching outlets will reduce risk of electric shock.
- b) **Avoid body contact with earthed or grounded surfaces, such as pipes, radiators, ranges and refrigerators.** There is an increased risk of electric shock if your body is earthed or grounded.
- c) **Do not expose power tools to rain or wet conditions.** Water entering a power tool will increase the risk of electric shock.
- d) **Do not abuse the cord. Never use the cord for carrying, pulling or unplugging the power tool. Keep cord away from heat, oil, sharp edges or moving parts.** Damaged or entangled cords increase the risk of electric shock.
- e) **When operating a power tool outdoors, use an extension cord suitable for outdoor use.** Use of a cord suitable for outdoor use reduces the risk of electric shock.
- f) **If operating a power tool in a damp location is unavoidable, use a residual current device (RCD) protected supply.** Use of an RCD reduces the risk of electric shock.

3) PERSONAL SAFETY

- a) **Stay alert, watch what you are doing and use common sense when operating a power tool. Do not use a power tool while you are tired or under the influence of drugs, alcohol or medication.** A moment of inattention while operating power tools may result in serious personal injury.
- b) **Use personal protective equipment. Always wear eye protection.** Protective equipment such as dust mask, non-skid safety shoes, hard hat, or hearing protection used for appropriate conditions will reduce personal injuries.
- c) **Prevent unintentional starting. Ensure the switch is in the off-position before connecting to power source and/or battery pack, picking up or carrying the tool.** Carrying power tools with your finger on the switch or energising power tools that have the switch on invites accidents.
- d) **Remove any adjusting key or wrench before turning the power tool on.** A wrench or a key left attached to a rotating part of the power tool may result in personal injury.
- e) **Do not overreach. Keep proper footing and**

balance at all times. This enables better control of the power tool in unexpected situations.

- f) **Dress properly. Do not wear loose clothing or jewellery. Keep your hair, clothing and gloves away from moving parts.** Loose clothes, jewellery or long hair can be caught in moving parts.
- g) **If devices are provided for the connection of dust extraction and collection facilities, ensure these are connected and properly used.** Use of these devices can reduce dust-related hazards.

4) POWER TOOL USE AND CARE

- a) **Do not force the power tool. Use the correct power tool for your application.** The correct power tool will do the job better and safer at the rate for which it was designed.
- b) **Do not use the power tool if the switch does not turn it on and off.** Any power tool that cannot be controlled with the switch is dangerous and must be repaired.
- c) **Disconnect the plug from the power source and/or the battery pack from the power tool before making any adjustments, changing accessories, or storing power tools.** Such preventive safety measures reduce the risk of starting the power tool accidentally.
- d) **Store idle power tools out of the reach of children and do not allow persons unfamiliar with the power tool or these instructions to operate the power tool.** Power tools are dangerous in the hands of untrained users.
- e) **Maintain power tools. Check for misalignment or binding of moving parts, breakage of parts and any other condition that may affect the power tool's operation. If damaged, have the power tool repaired before use.** Many accidents are caused by poorly maintained power tools.
- f) **Keep cutting tools sharp and clean.** Properly maintained cutting tools with sharp cutting edges are less likely to bind and are easier to control.
- g) **Use the power tool, accessories and tool bits etc. in accordance with these instructions, taking into account the working conditions and the work to be performed.** Use of the power tool for operations different from those intended could result in a hazardous situation.

5) BATTERY TOOL USE AND CARE

- a) **Recharge only with the charger specified by the manufacturer.** A charger that is suitable for one

type of battery pack may create a risk of fire when used with another battery pack.

- b) **Use power tools only with specifically designated battery packs.** Use of any other battery packs may create a risk of injury and fire.
- c) **When battery pack is not in use, keep it away from other metal objects, like paper clips, coins, keys, nails, screws or other small metal objects, that can make a connection from one terminal to another. Shorting the battery terminals together may cause burns or a fire.**
- d) **Under abusive conditions, liquid may be ejected from the battery; avoid contact. If contact accidentally occurs, flush with water. If liquid contacts eyes, additionally seek medical help.** Liquid ejected from the battery may cause irritation or burns.

6) SERVICE

- a) **Have your power tool serviced by a qualified repair person using only identical replacement parts.** This will ensure that the safety of the power tool is maintained.

SAFETY INSTRUCTIONS FOR ALL OPERATIONS

SAFETY WARNINGS COMMON FOR GRINDING OR ABRASIVE CUTTING-OFF OPERATIONS:

- a) **This power tool is intended to function as a grinder or cut-off tool.** Read all safety warnings, instructions, illustrations and specifications provided with this power tool. Failure to follow all instructions listed below may result in electric shock, fire and/or serious injury.
- b) **Operations such as sanding, wire brushing, polishing are not recommended to be performed with this power tool.** Operations for which the power tool was not designed may create a hazard and cause personal injury.
- c) **Do not use accessories which are not specifically designed and recommended by the tool manufacturer.** Just because the accessory can be attached to your power tool, it does not assure safe operation.
- d) **The rated speed of the accessory must be at**

least equal to the maximum speed marked on the power tool. Accessories running faster than their rated speed can break and fly apart.

- e) **The outside diameter and the thickness of your accessory must be within the capacity rating of your power tool.** Incorrectly sized accessories cannot be adequately guarded or controlled.
- f) **Threaded mounting of accessories must match the grinder spindle thread. For accessories mounted by flanges, the arbour hole of the accessory must fit the locating diameter of the flange.** Accessories that do not match the mounting hardware of the power tool will run out of balance, vibrate excessively and may cause loss of control.
- g) **Do not use a damaged accessory. Before each use inspect the accessory such as abrasive wheels for chips and cracks, backing pad for cracks, tear or excess wear, wire brush for loose or cracked wires. If power tool or accessory is dropped, inspect for damage or install an undamaged accessory.** After inspecting and installing an accessory, position yourself and bystanders away from the plane of the rotating accessory and run the power tool at maximum no-load speed for one minute.

Damaged accessories will normally break apart during this test time.

- h) **Wear personal protective equipment. Depending on application, use face shield, safety goggles or safety glasses. As appropriate, wear dust mask, hearing protectors, gloves and workshop apron capable of stopping small abrasive or workpiece fragments.** The eye protection must be capable of stopping flying debris generated by various operations. The dust mask or respirator must be capable of filtering particles generated by your operation. Prolonged exposure to high intensity noise may cause hearing loss.
- i) **Keep bystanders a safe distance away from work area.** Anyone entering the work area must wear personal protective equipment. Fragments of workpiece or of a broken accessory may fly away and cause injury beyond immediate area of operation.
- j) **Hold the power tool by insulated gripping surfaces only, when performing an operation where the cutting tool may contact hidden wiring.** Contact with a "live" wire will also make

exposed metal parts of the power tool “live” and could give the operator an electric shock.

- k) **Never lay the power tool down until the accessory has come to a complete stop.** The spinning accessory may grab the surface and pull the power tool out of your control.
 - l) **Do not run the power tool while carrying it at your side.** Accidental contact with the spinning accessory could snag your clothing, pulling the accessory into your body.
 - m) **Regularly clean the power tool's air vents.** The motor's fan will draw the dust inside the housing and excessive accumulation of powdered metal may cause electrical hazards.
 - n) **Do not operate the power tool near flammable materials.** Sparks could ignite these materials.
 - o) **Do not use accessories that require liquid**
- b) Never place your hand near the rotating accessory. Accessory may kickback over your hand.
 - c) Do not position your body in the area where power tool will move if kickback occurs. Kickback will propel the tool in direction opposite to the wheel's movement at the point of snagging.
 - d) Use special care when working corners, sharp edges etc. Avoid bouncing and snagging the accessory. Corners, sharp edges or bouncing have a tendency to snag the rotating accessory and cause loss of control or kickback.
 - e) Do not attach a saw chain woodcarving blade or toothed saw blade. Such blades create frequent kickback and loss of control.

FURTHER SAFETY INSTRUCTIONS FOR ALL OPERATIONS KICKBACK AND RELATED WARNINGS

Kickback is a sudden reaction to a pinched or snagged rotating wheel, backing pad, brush or any other accessory. Pinching or snagging causes rapid stalling of the rotating accessory which in turn causes the uncontrolled power tool to be forced in the direction opposite of the accessory's rotation at the point of the binding.

For example, if an abrasive wheel is snagged or pinched by the workpiece, the edge of the wheel that is entering into the pinch point can dig into the surface of the material causing the wheel to climb out or kick out. The wheel may either jump toward or away from the operator, depending on direction of the wheel's movement at the point of pinching. Abrasive wheels may also break under these conditions. Kickback is the result of power tool misuse and/or incorrect operating procedures or conditions and can be avoided by taking proper precautions as given below.

- a) Maintain a firm grip on the power tool and position your body and arm to allow you to resist kickback forces. Always use auxiliary handle, if provided, for maximum control over kickback or torque reaction during start-up. The operator can control torque reactions or kickback forces, if proper precautions are taken.
- b) Never place your hand near the rotating accessory. Accessory may kickback over your hand.
- c) Do not position your body in the area where power tool will move if kickback occurs. Kickback will propel the tool in direction opposite to the wheel's movement at the point of snagging.
- d) Use special care when working corners, sharp edges etc. Avoid bouncing and snagging the accessory. Corners, sharp edges or bouncing have a tendency to snag the rotating accessory and cause loss of control or kickback.
- e) Do not attach a saw chain woodcarving blade or toothed saw blade. Such blades create frequent kickback and loss of control.

SAFETY WARNINGS SPECIFIC FOR GRINDING AND ABRASIVE CUTTING-OFF OPERATIONS:

- a) Use only wheel types that are recommended for your power tool and the specific guard designed for the selected wheel. Wheels for which the power tool was not designed cannot be adequately guarded and are unsafe
- b) The grinding surface of centre depressed wheels must be mounted below the plane of the guard lip. An improperly mounted wheel that projects through the plane of the guard lip cannot be adequately protected.
- c) The guard must be securely attached to the power tool and positioned for maximum safety, so the least amount of wheel is exposed towards the operator. The guard helps to protect the operator from broken wheel fragments, accidental contact with wheel and sparks that could ignite clothing.
- d) Wheels must be used only for recommended applications. For example: do not grind with the side of cut-off wheel. Abrasive cut-off wheels are intended for peripheral grinding, side forces applied to these wheels may cause them to shatter.
- e) Always use undamaged wheel flanges that are of correct size and shape for your selected wheel. Proper wheel flanges support the wheel thus reducing the possibility of wheel breakage. Flanges for cut-off wheels may be different from grinding wheel flanges.

- f) Do not use worn down wheels from larger power tools. Wheel intended for larger power tool is not suitable for the higher speed of a smaller tool and may burst.

ADDITIONAL SAFETY WARNINGS SPECIFIC FOR ABRASIVE CUTTING-OFF OPERATIONS:

- a) **Do not “jam” the cut-off wheel or apply excessive pressure. Do not attempt to make an excessive depth of cut.** Overstressing the wheel increases the loading and susceptibility to twisting or binding of the wheel in the cut and the possibility of kickback or wheel breakage.
- b) **Do not position your body in line with and behind the rotating wheel.** When the wheel, at the point of operation, is moving away from your body, the possible kickback may propel the spinning wheel and the power tool directly at you.
- c) **When wheel is binding or when interrupting a cut for any reason, switch off the power tool and hold the power tool motionless until the wheel comes to a complete stop.** Never attempt to remove the cut-off wheel from the cut while the wheel is in motion otherwise kickback may occur. Investigate and take corrective action to eliminate the cause of wheel binding.
- d) **Do not restart the cutting operation in the workpiece. Let the wheel reach full speed and carefully re-enter the cut.** The wheel may bind, walk up or kickback if the power tool is restarted in the workpiece.
- e) **Support panels or any oversized workpiece to minimize the risk of wheel pinching and kickback. Large workpieces tend to sag under their own weight.** Supports must be placed under the workpiece near the line of cut and near the edge of the workpiece on both sides of the wheel.
- f) **Use extra caution when making a “pocket cut” into existing walls or other blind areas.** The protruding wheel may cut gas or water pipes, electrical wiring or objects that can cause kickback.

GENERAL SAFETY WARNINGS



WARNING Read all safety warnings and all instructions. Failure to follow the warnings and instructions may result in electric shock, fire and/or serious injury.

Save all warnings and instructions for future reference.

- This appliance is not intended for use by persons (including children) with reduced physical, sensory or mental capabilities, or lack of experience and knowledge, unless they have been given supervision or instruction concerning use of the appliance by a person responsible for their safety.
- Children should be supervised to ensure that they do not play with the appliance.
If the supply cord is damaged, it must be replaced by the manufacturer, its service agent or similarly qualified persons in order to avoid a hazard.

ADDITIONAL SAFETY INSTRUCTIONS FOR YOUR BATTERY CHARGER

1. Before charging, read the instructions.
2. For charge Li-ion battery pack only.
3. Do not charge a leaking battery.
4. Do not use chargers for works other than those for which they are designed.
5. Before charging, ensure your charger is matching the local AC supply.
6. The charging device must be protected from moisture.
7. Do not use the charging device in the open.
8. Do not short out the contacts of battery or charger.
9. Respect the polarity “+/-“ when charging.
10. Do not open the unit and keep out of the reach of children.
11. Do not charge the batteries of other manufactures or ill-suited models.
12. Ensure that the connection between the battery charger and battery is correctly positioned and is not obstructed by foreign bodies.
13. Keep battery charger’s slots are free of foreign objects and protect against dirt and humidity. Store in a dry and frost-free place.
14. When charging batteries, ensure that the battery charger is in a well-ventilated area and away

from inflammable materials. Batteries can get hot during charging. Do not overcharge any batteries. Ensure that batteries and chargers are not left unsupervised during charging.

15. Do not recharge non-rechargeable batteries, as they can overheat and break.
16. Longer life and better performance can be obtained if the battery pack is charged when the air temperature is between 18 °C and 24 °C. Do not charge the battery pack in air temperatures below 4.5 °C, or above 40.5 °C. This is important as it can prevent serious damage to the battery pack.
17. Charge only battery pack of the same model provided by manufacturer and of models recommended by manufacturer.

SAFETY WARNINGS FOR BATTERY PACK

- a) Do not dismantle, open or shred cells or battery pack.
- b) Do not short-circuit a battery pack. Do not store battery packs haphazardly in a box or drawer where they may short-circuit each other or be short-circuited by conductive materials. When battery pack is not in use, keep it away from other metal objects, like paper clips, coins, keys, nails, screws or other small metal objects, that can make a connection from one terminal to another. Shorting the battery terminals together may cause burns or a fire.
- c) Do not expose battery pack to heat or fire. Avoid storage in direct sunlight.
- d) Do not subject battery pack to mechanical shock.
- e) In the event of battery leaking, do not allow the liquid to come into contact with the skin or eyes. If contact has been made, wash the affected area with copious amounts of water and seek medical advice.
- f) Seek medical advice immediately if a cell or battery pack has been swallowed.
- g) Keep battery pack clean and dry.
- h) Wipe the battery pack terminals with a clean dry cloth if they become dirty.
- i) Battery pack needs to be charged before use. Always refer to this instruction and use the correct charging procedure.
- j) Do not maintain battery pack on charge when not in use.
- k) After extended periods of storage, it may be necessary to charge and discharge the battery pack several times to obtain maximum performance.
- l) Battery pack gives its best performance when it is operated at normal room temperature (20 °C ± 5 °C).
- m) When disposing of battery packs, keep battery packs of different electrochemical systems separate from each other.
- n) Recharge only with the charger specified by manufacturer. Do not use any charger other than that specifically provided for use with the equipment. A charger that is suitable for one type of battery pack may create a risk of fire when used with another battery pack.
- o) Do not use any battery pack which is not designed for use with the equipment.
- p) Keep battery pack out of the reach of children.
- q) Retain the original product literature for future reference.
- r) Remove the battery from the equipment when not in use.
- s) Dispose of properly.

SYMBOL



To reduce the risk of injury, user must read instruction manual



Warning



Wear ear protection



Wear eye protection



Wear dust mask



RCM marking



Li-Ion Li-Ion

This product has been marked with a symbol relating to 'separate collection' for all battery packs and battery pack. It will then be recycled or dismantled in order to reduce the impact on the environment. Battery packs can be hazardous for the environment and for human health since they contain hazardous substances.



Do not burn

Batteries may enter water cycle if disposed improperly, which can be hazardous for ecosystem. Do not dispose of waste batteries as unsorted municipal waste.



For indoor use only

T 3.15A



Fuse



Positive terminal



Negative terminal



Not permitted for face grinding with abrasive cutting off wheels

TECHNICAL DATA

Type **RD2923.9 (RD-designation of machinery, representative of Angle Grinder)**

Rated voltage	18V $\overline{\text{---}}$
Rated speed	8800/min
Disc diameter	115mm
Disc bore	22.2mm
Spindle thread	M14
Machine weight	1.83Kg

The accessories of battery charger and battery pack illustrated or described are not included in RD2923.9 delivery.

CHARGING PROCEDURE



NOTE: Before using the tool, read the instruction book carefully.

1. CHARGING YOUR BATTERY PACK A) CHARGING THE BATTERY

The battery charger supplied is matched to the Li-Ion battery installed in the machine. Do not use another battery charger.

The Li-ion battery is protected against deep discharging. When the battery is empty, the machine is switched off by means of a protective circuit: The tool holder no longer rotates.

In a warm environment or after heavy use, the battery pack may become too hot to permit charging. Allow time for the battery to cool down before recharging. When the battery pack is charged for the first time and after prolonged storage, the battery pack will accept a 100% charge after several charge and discharge cycles.

B) TO REMOVE THE BATTERY PACK (SEE FIG. B)

Depress the Battery Pack Release Button (5) firmly first and then slide the Battery Pack out from your tool.

C) TO INSTALL THE BATTERY PACK (SEE FIG. B)

Slide the fully charged Battery Pack onto the tool with sufficient force until it clicks into position.

ABN: Australian Business Number. By this number, business information such as entity type, status, business location etc. can be found at website <http://abr.business.gov.au>.

ABN of Positac Australia Pty Ltd is 14 101 682 357

D) HOW TO CHARGE YOUR BATTERY PACK (SEE FIG. C) BEFORE PUTTING INTO OPERATION

Charging the battery

NOTE:

- Do not use any charger other than that specifically provided for use with the equipment.
- If the battery pack is very hot you must remove your battery pack from the charger and allow time for the battery to cool down before recharging.
- The battery in your new tool is not charged when it leaves the plant. Therefore it must be full charged before using the first time.
- Please charge the battery to reach full or no less than half charge before storage. If the tool will not be used for long periods of time, charge the battery every 3-6 months.

Charging procedure

- Plug the charger into an appropriate outlet. The light will be green.
- Slide the battery pack into the charger, the light will turn to red to indicate the charging process has started.
- When charging is completed, the light will turn to green. The pack is now fully charged, unplug the charger and remove the battery pack.

WARNING: When battery charge runs out after continuously use or exposure to direct sunlight or heat, allow time for the tool to cool down before re-charging to achieve the full charge.

Charging indicator

This charger is designed to detect some problems that can arise with battery packs. Indicator lights indicate problems (see table below). If this occurs, insert a new battery pack to determine if the charger is OK. If the new battery charges correctly, then the original pack is defective and should be returned to a service center or recycling service center. If the new battery pack displays the same problem as the original Battery Pack, have the charger tested at an authorized service center.

Battery charger and battery pack illustrated or described are not included in RD2923.9 delivery.

OPERATING INSTRUCTIONS

Intended Use

The machine is intended for cutting, roughing and

brushing metal and stone materials without using water. For cutting metal, a special safety guard for cutting(not included)must be used.

1. Guard Adjustment (SEE FIG. D)

Before any work on the machine itself, remove the battery pack from your tool.

For work with grinding or cutting discs, the wheel guard must be mounted.

Wheel Guard for Grinding

The coded projection on the wheel guard ensures that only a guard that fits the machine type can be mounted.

Open the clamping lever. Place the wheel guard with coded projection into the coded groove on the spindle of the machine head and rotate to the required position (working position).

To fasten the wheel guard, close the clamping lever. The closed side of the wheel guard must always point to the operator.

Note: with the clamping lever open the clamp adjusting nut can be adjusted to ensure the guard is securely clamped after the clamping lever is finally closed.

Wheel Guard for Cutting

Warning! For cutting metal, always work with the guard for cutting (not supplied).

The wheel guard for cutting is mounted in the same manner as the wheel guard for grinding.

2. INSTALLING AND ADJUSTING AUXILIARY HANDLE (SEE FIG. E)

You have the option of two working positions to provide the safest and most comfortable control of your angle grinder. The handle can be screwed clockwise into either hole on the sides of the gear case.

NOTE: this handle should be used at all times to maintain complete control of the tool.

3. FITTING THE DISCS (SEE FIG. F1-F3)

Put the inner flange onto the tool spindle. Ensure it is located on the two flats of spindle (see F1).

Place the disc on the tool spindle and inner flange. Ensure it is correctly located. Fit the threaded outer flange making sure it is facing in the correct direction for the type of disc fitted. For grinding discs, the flange is fitted with the raised portion facing towards the disc. For cutting discs, the flange is fitted with the raised portion facing away from the disc (see F2).

Press in the spindle lock button (2) and rotate the spindle by hand until it is locked. Keeping the lock

button pressed in, tighten the outer flange with the spanner provided. (See F3)

Note:

After mounting the grinder tool and before switch on, check that the grinding tool is correctly mounted and that it can be turned freely, make sure that the grinding tool does not graze against the protecting guard or other parts.

4. SPINDLE LOCK BUTTON

Clean the grinder spindle and all parts to be mounted. For clamping and loosening the grinding tools, lock the grinder spindle with the spindle lock button.

Warning: Actuate the spindle lock button only when the grinder spindle is at a stand still!

5. HAND GRIP AREAS (SEE FIG. G)

Always hold your angle grinder firmly with both hands when operating.

6. SLIDE ON/OFF SWITCH (SEE FIG. H)

To start the power tool, first press the back of on/off switch, then push the on/off switch (6) forward.

To lock the on/off switch, press the on/off switch down at the front until it engages.

To switch off the power tool, briefly press down the back of the on/off switch and then release it.

Note: The angle grinder is equipped with "accidental start protection" and will not start if the battery is inserted while the switch is in the "on" position.

WARNING! All ensure that the wheel guard is securely attached to the grinder at all times when operating this tool.

7. TO USE THE GRINDER (SEE FIG. J)

Attention: Do not switch the grinder on while the disc is in contact with the workpiece. Allow the disc to reach full speed before starting grinding.

Hold your angle grinder with one hand on the main handle and other hand firmly around the auxiliary handle.

Always position the guard so that as much of the exposed disc as possible is pointing away from you. Be prepared for a stream of sparks when the disc touches the metal.

For best tool control, material removal and minimum overloading, keep an angle between the disc and the workpiece surface at approximately 15° to 30° when

grinding.

Use cautiously when working into corners as contacting with the intersecting surface may cause the grinder to jump or twist.

When grinding is complete, allow the workpiece to cool. Do not touch the hot surface.

8. Overload

Overloading will cause damage to the motor of your angle grinder. This can happen if your angle grinder is subjected to heavy use for prolonged periods of time. Never attempt to exert too much pressure on your angle grinder to speed up your work.

The abrasive discs operate more efficiently when light pressure is exerted, thus avoiding a drop in the speed of your angle grinder.

If your angle grinder becomes too hot, run it no load for 2-3 minutes until it has cooled to normal operation temperature.

9. Disposal of an exhausted battery pack

To preserve natural resources, please recycle or dispose of the battery pack properly. This battery pack contains Lithium batteries. Consult your local waste authority for information regarding available recycling and/or disposal options. Discharge your battery pack by operating your angle grinder, then remove the battery pack from the angle grinder housing and cover the battery pack connections with heavy duty adhesive tape to prevent short circuit and energy discharge. Do not attempt to open or remove any of the components.

WORKING HINTS FOR YOUR ANGLE GRINDER

1. WHY DOES THE DRILL NOT TURN ON WHEN YOU PRESS THE SWITCH?

1. Always start at no load to achieve maximum speed then start working.
2. Do not force the disc to work faster, reducing the Disc's moving speed means longer working time.
3. Always work with a 15-30 angle between disc and workpiece. Larger angles will cut ridges into the workpiece and affect the surface finish. Move the angle grinder across and back and forth over the workpiece.
4. When using a cutting disc never change the cutting

- angle otherwise you will stall the disc and angle grinder motor or break the disc. When cutting, only cut in the opposite direction to the disc rotation. If you cut in the same direction as the disc rotation the disc may push itself out of the cut slot.
- When cutting very hard material best results can be achieved with a diamond disc.
 - When using a diamond disc it will become very hot. If this happens you will see a full ring of sparks around the rotating disc. Stop cutting and allow to cool at no load speed for 2-3 minutes.
 - Always ensure the workpiece is firmly held or clamped to prevent movement.
- Immediately wash any leakage from hands, skin or clothes with soap and water.
- The power-draw from the battery generates heat. This is increased as the energy draw increases. You will not damage the battery pack and the generated heated heat is normal. Should you desire to cool it down, simply allow the angle grinder to cool off prior to continuing work.
 - The battery pack may get warm when charging. This is normal. It is a result from the stepping down of the chemical reactions inside the batteries during the charging process.
 - The charger will get warm during charging. This is normal. It is a result of the stepping down of the main supply.

MAINTENANCE

Remove the battery before carrying out any adjustment, servicing or maintenance.

There are no user serviceable parts in your power tool. Never use water or chemical cleaners to clean your power tool. Wipe clean with a dry cloth. Always store your power tool in a dry place. Keep the motor ventilation slots clean. Keep all working controls free of dust. Occasionally you may see sparks through the ventilation slots. This is normal and will not damage your power tool.

If the supply cord is damaged, it must be replaced by the manufacturer, its service agent or similarly qualified persons in order to avoid a hazard.

TROUBLESHOOTING

Although your new angle grinder is really very simple to operate, if you do experience problems, please check the following:

- If your grinder disc wobbles or vibrates, check if the outer flange is tightened or if the disc is correctly located on the flange plate.
- Do not use the damaged disc as it may disintegrate. Remove it and replace with a new disc. Dispose of old disc sensibly.
- If working on aluminum or a similar soft alloy, the disc will soon become clogged and will not grind effectively.
- A small amount of battery pack leakage may occur under extreme temperatures or after heavy use.

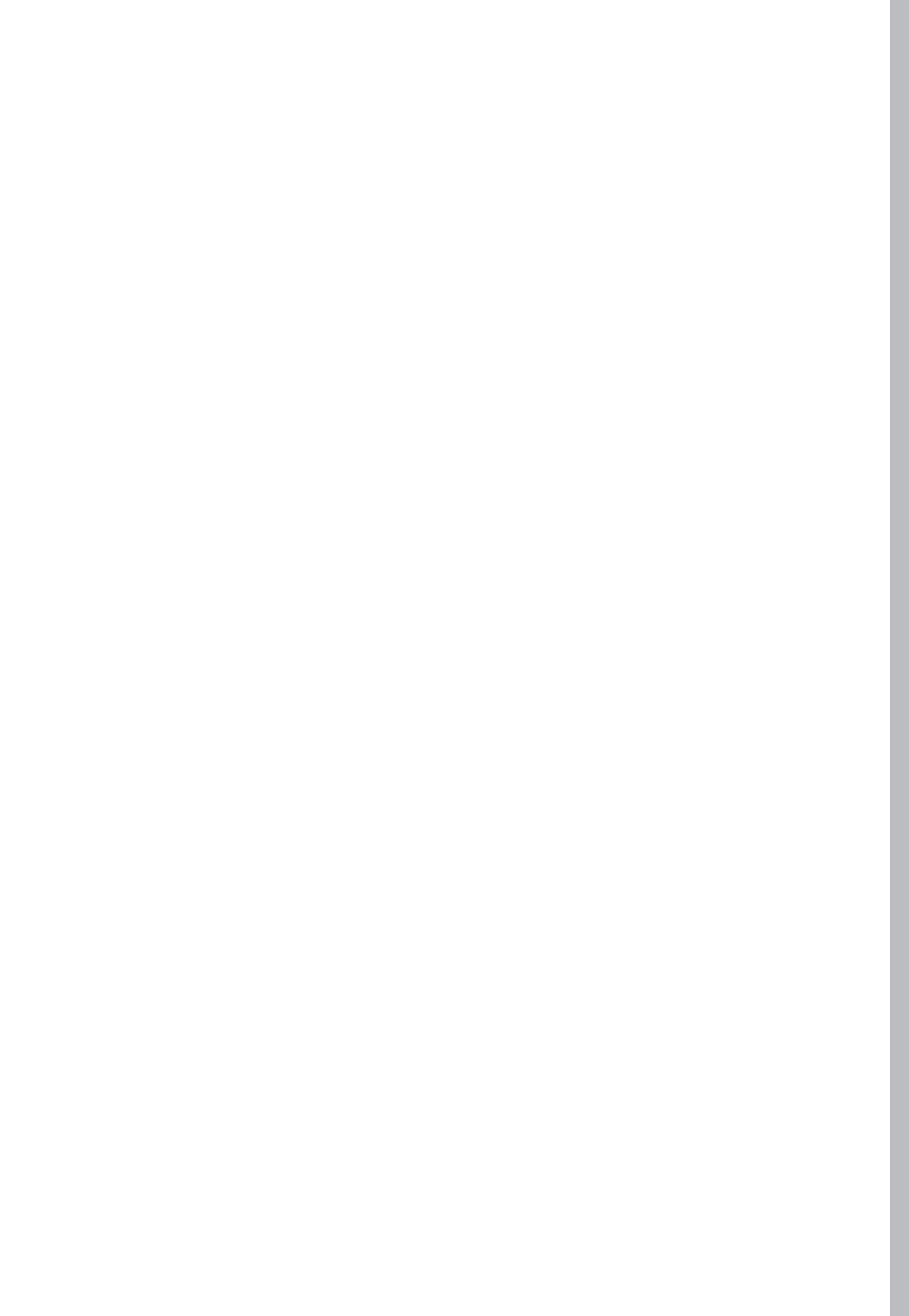



POSITEC AUSTRALIA PTY LTD
ABN 14 101 682 357

MADE IN PRC