

LOCKLY Enjoy the freedom™

ACCESS TOUCH PRO

INSTALLATION GUIDE

**WI-FI CONNECTED
FINGERPRINT DEADBOLT**

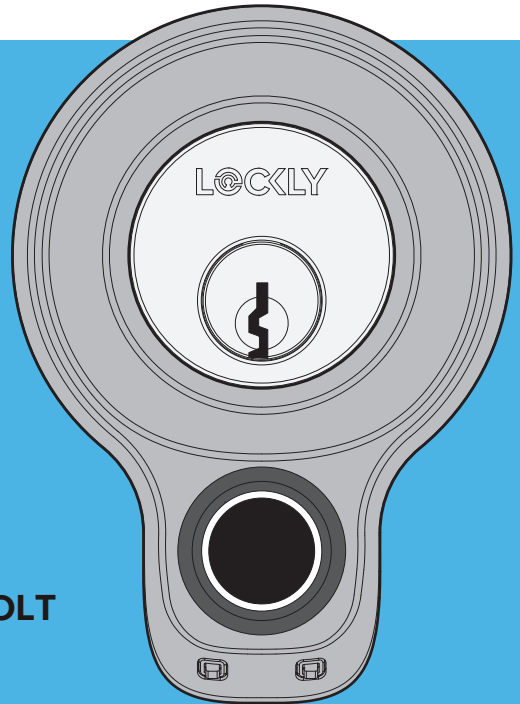

Welcome!

This guide will walk you through step-by-step how to install and get your Lockly Access Touch Pro up and running. Installation generally takes less than 30 minutes. If you have any questions please reference our online support at: [Lockly.com/support](https://lockly.com/support) or call (669) 500-8835 for help.



Reference installation parts overview foldout on back page

Preparation

To complete installation, you would need the following:

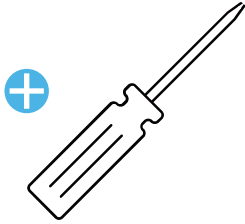

Phillips Screwdriver

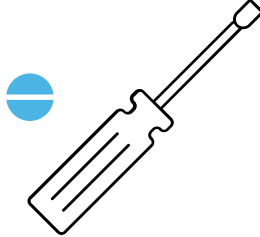

Flathead Screwdriver

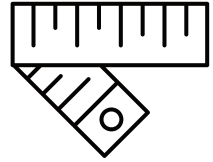

Tape measure or ruler

Prepare door and remove existing lock. If necessary, use provided Installation Template to prepare door.

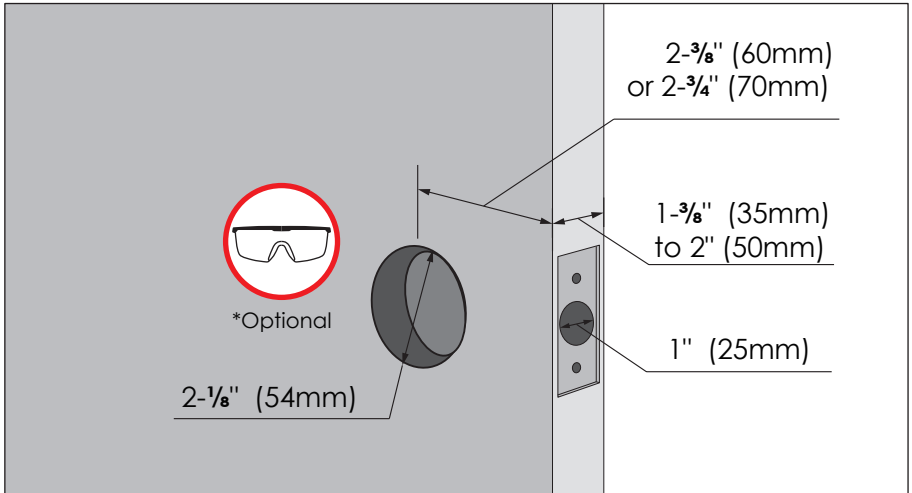

* Use goggles to protect eyes if you need to drill door holes.

Step 1

ADJUST DEADBOLT AND INSTALL

Deadbolt slot must align to the center of the door hole. Adjust as shown if needed.

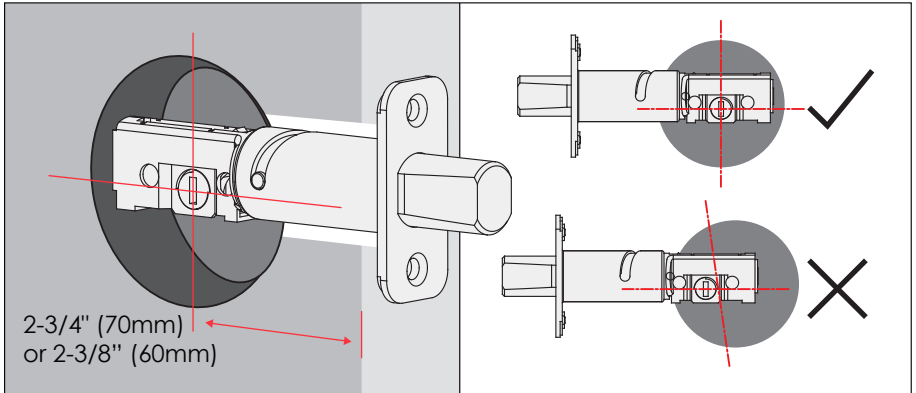

The deadbolt comes set to 2-3/4" (70mm). Adjust length to 2-3/8" (60mm) if necessary (wear gloves to protect from possible pinching).

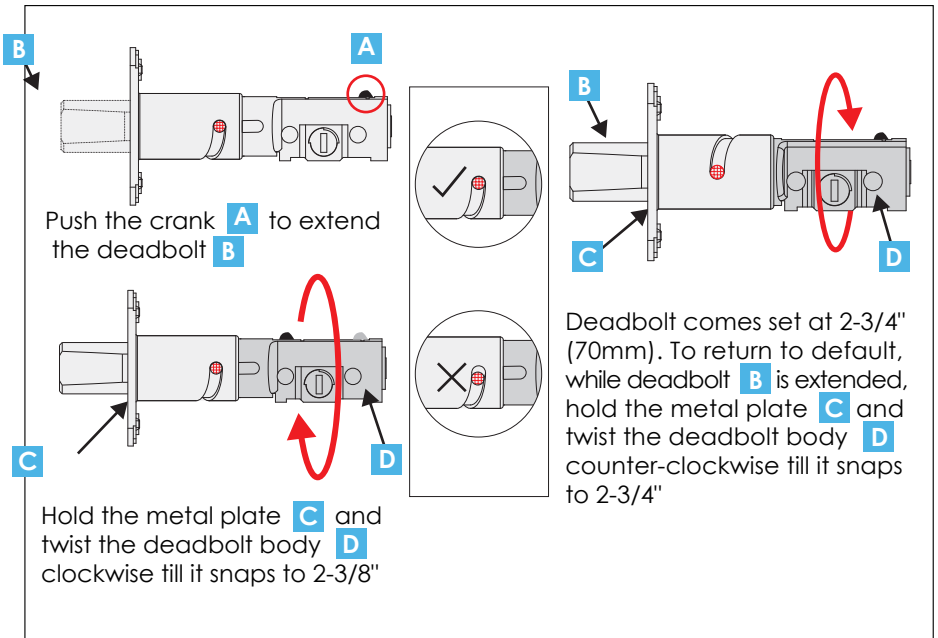

Extend the deadbolt by inserting a flat-head screwdriver into the slot and turning clockwise.

Insert deadbolt to the door edge, make sure that the right side is up and the slot is in the vertical position. Secure with 2 **K** screws.

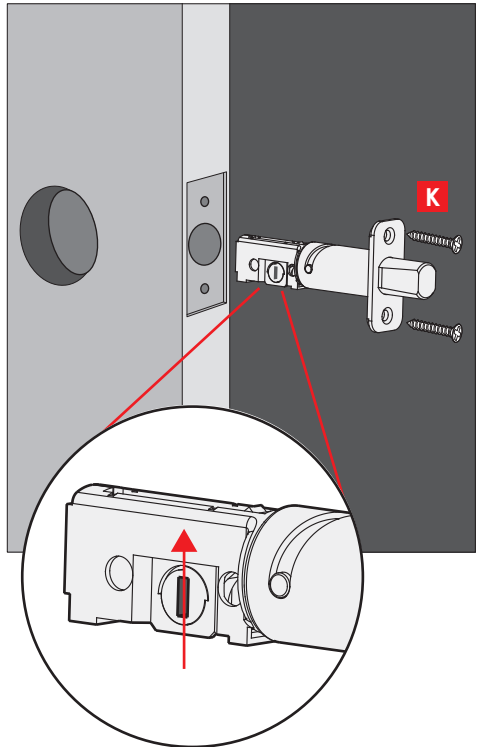
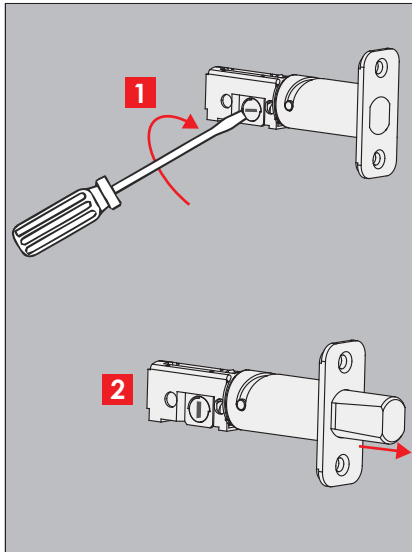

Step 2

INSTALLING EXTERIOR ASSEMBLY (B)

Before mounting exterior lock assembly (B) make sure torque blade is in the vertical position while deadbolt is extended [1].

Place assembly and torque blade through the deadbolt slot and guide connection cables through the cross-bore hole under the deadbolt as shown. Align and secure until flush to exterior door surface.

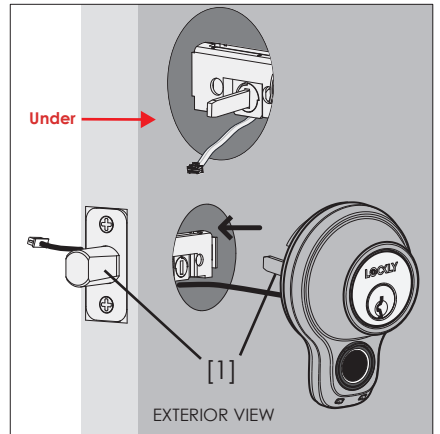
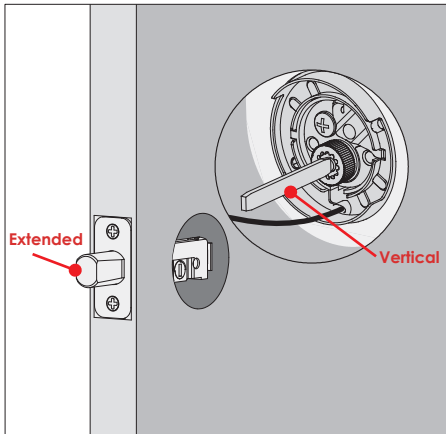
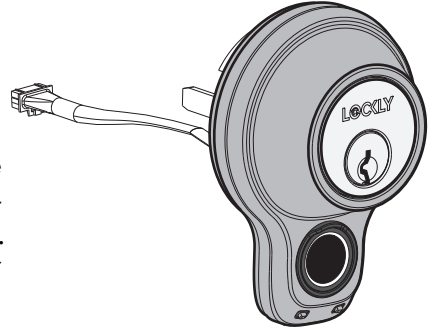

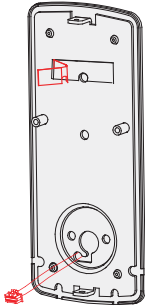

1: Check mounting plate **D** alignment to door hole before securing with adhesive strips.

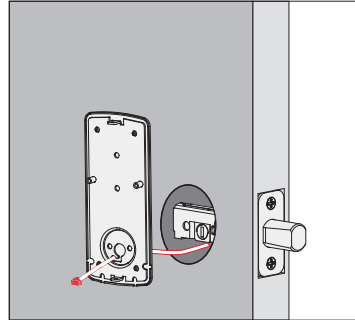

2: Align and secure mounting plate with adhesive strips. Guide connection cable through and secure to the lower left notched hole.

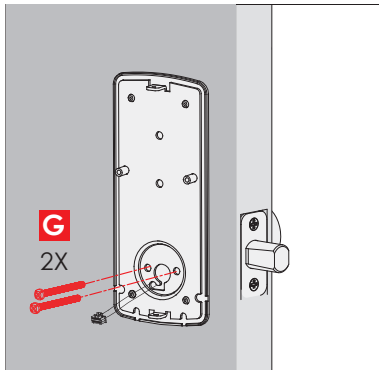

3: Insert, tighten by hand 2 **G** screws located on the left and right of the blade. Check alignment and tighten with screwdriver until mounting plate is securely placed on door.

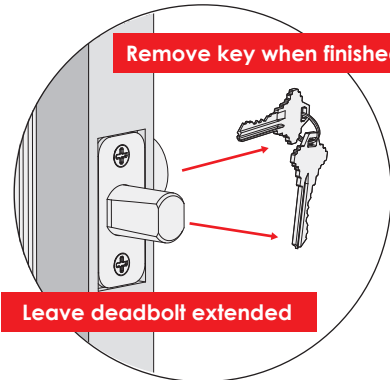

4: Use the key to ensure deadbolt locks and unlocks smoothly (no binding or rubbing). **IMPORTANT: when finished, leave the deadbolt extended and remove the key before proceeding to the next step.**

TIP: when installing screws by hand, turn screws clockwise several turns then counterclockwise one turn to ensure smooth threading and no cross threading.

Do not install the wired door sensor yet. You will install in Step 6.

About door sensors

Door sensors provide real-time door condition status, such as the ability to verify if the door is securely closed. It also sends push notifications to your phone whenever your door opens and enables voice control with Amazon Alexa or Hey Google.

Lockly Access Touch Pro comes with a pre-wired door sensors consisting of two parts:

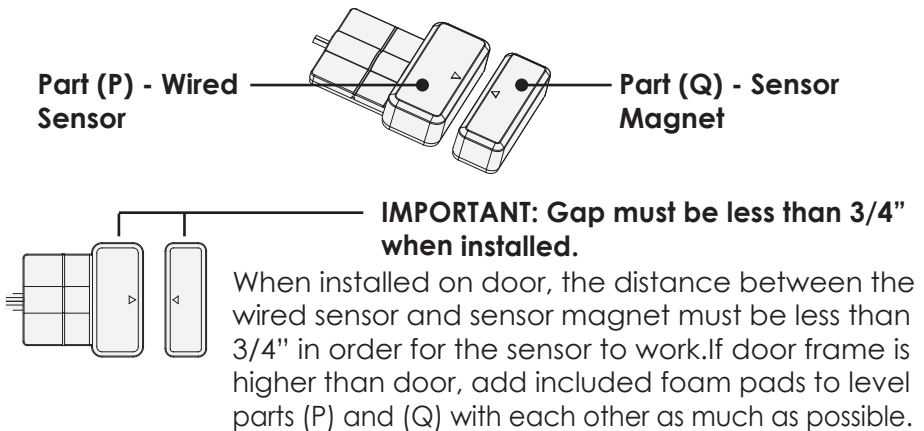

TIP: Lockly door sensors comes in Grey (PGA715) and Matte Black (PGA716) that can be ordered through our customer hotline: (669) 500-8835 or by email: help@Lockly.com.

Removal of Sensor (optional)

There may be circumstances where the sensor cannot be installed because of molding/door limitations or is not aesthetically desirable. The sensor wired to the lock is removable by carefully pulling its connector from the circuit board. **If removed, some features and functionality will not be available, such as real-time condition status.**

When installing the wired door sensors, make sure the arrow on the wired sensor **P** aligns to the arrow of the sensor magnet **Q** as close as possible.

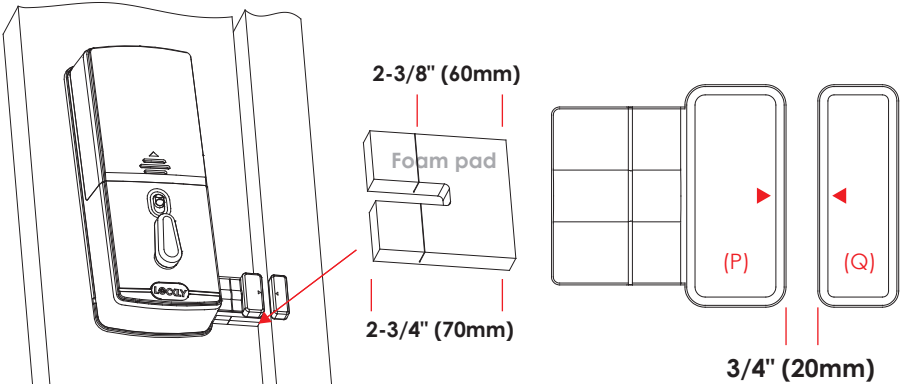

The sensors need to be as close to level as possible. If needed, use the adhesive foam pad(s) to adjust the height of the wired sensor.

Sensors can be positioned on either left or right side (see next page).

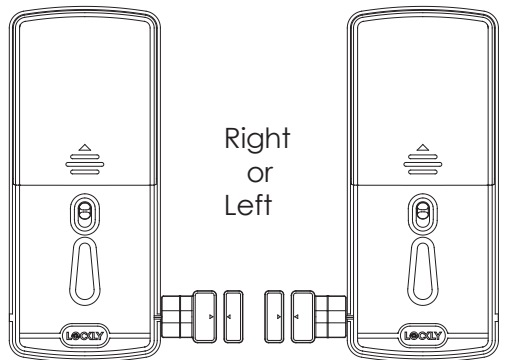

The interior assembly comes with the pre-installed wired door sensor setup for a right swing doors with 2 3/4" (70mm) backset*.

Trim excess part (P) for doors with 2 3/8" (60mm) backset as shown below.

For left swing doors, re-route the door sensor wire through the side channel. Pull the foam pad then re-insert to secure the wire. Discard the excess part (e) for doors with 2 3/8" (60mm) backset as shown below:

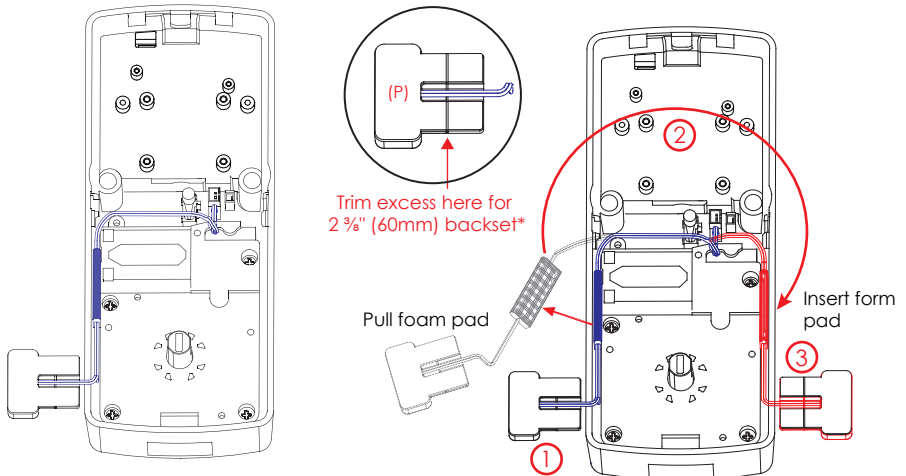

***Backset = distance of the door edge to the center of the cross-bore door hole.**

DO NOT INSTALL THE SENSORS YET

Step 4

INSTALLING INTERIOR ASSEMBLY (F)

Plug the cable coming through mounting plate **D** into the interior assembly **F** as shown. Tuck cable under eyelet hooks and route to the right on interior assembly **F**.

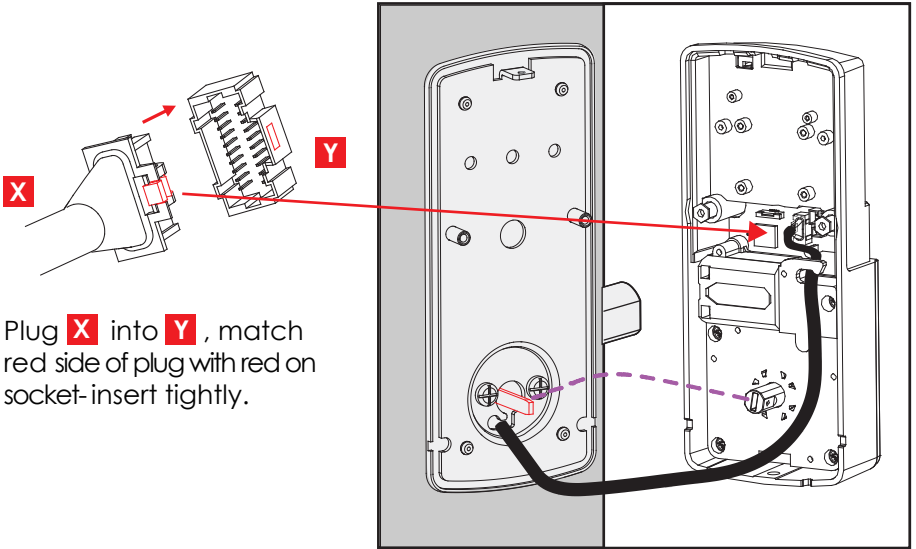

Plug **X** into **Y**, match red side of plug with red on socket-insert tightly.

Install Cable

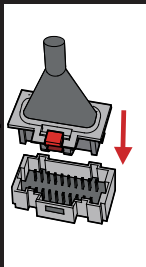

Remove Cable

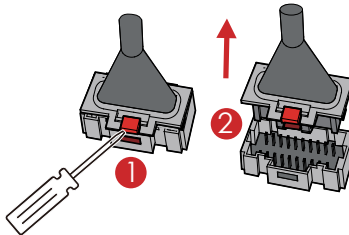

IMPORTANT:

If you need to disconnect this cable, use a screwdriver to hold down the tab (marked red) before carefully unplugging. **DO NOT FORCE** as this may result in damaging the lock.

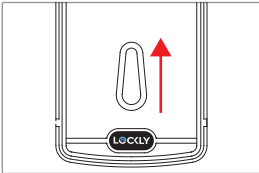
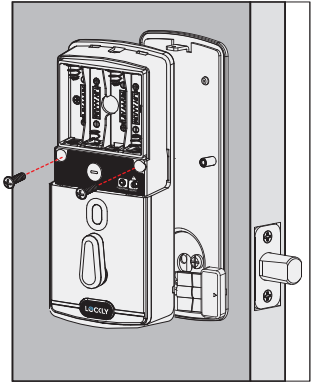
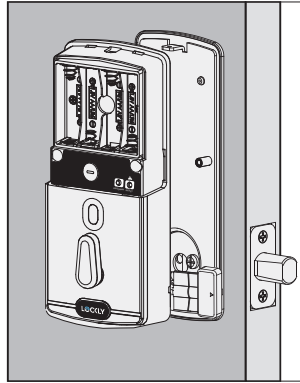
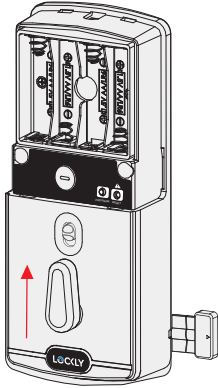

Torque Blade Thumb turn shaft

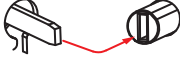

Align torque blade with thumb turn shaft, **make sure both are in the vertical position.**

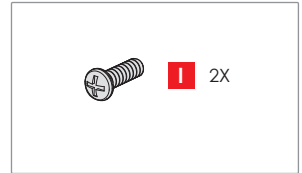

Before placing the interior **F** assembly onto the mounting plate, ensure the thumb turn is **vertical**.

Place the interior assembly against the mounting plate and make sure the torque blade is inserted to the thumb turn shaft.

Secure the interior assembly to mounting plate with 2 **F** screws.

Step 5

INSTALLING BATTERIES

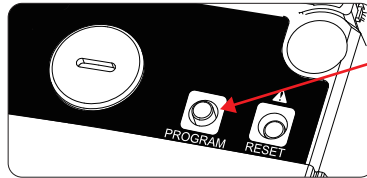
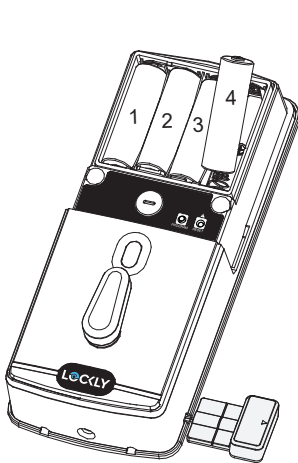

1: With door open and deadbolt **fully extended**, place ribbon inside compartment and **insert 4 batteries** (note correct -/+ polarity).

2: After all batteries are installed, **PRESS and HOLD the program button for 10S**. The lock will automatically start self-check (release program button once check starts). The self-check process determines right or left swinging door and is very important to ensure correct installation. **IMPORTANT: if lock is not properly installed it will open and close repeatedly.**

3: Once self-check completes ensure the lock operates smoothly by manually locking and unlocking the door using the deadbolt should operate smoothly without any interference or binding. If necessary, repeat step 2 and ensure that (a) the deadbolt was extended and (b) the torque blade was inserted vertically while the deadbolt was extended.

4: Once self-check is complete, install the battery cover **H** and secure with screw on top (do not over tighten).

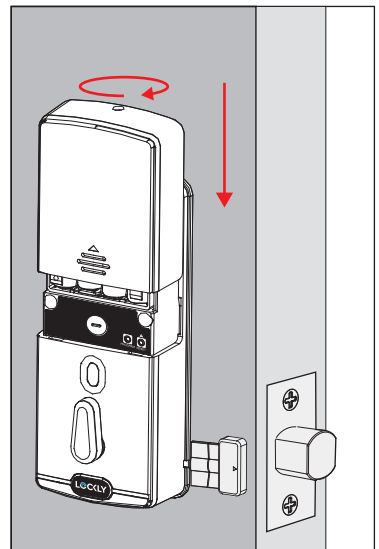

Make sure you have prepared the door sensors for installation, see step 3.

LOCK SENSOR (P)

Install on the interior side only. If necessary, trim tab from sensor **P** for doors with 2-3/8" (60mm) backset. Clean surface of door and doorframe, remove film from adhesive, attach and secure close to door edge as shown.

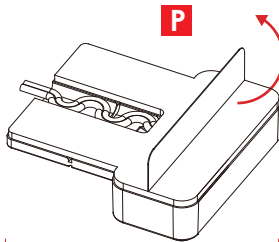

2-3/4" (70mm)

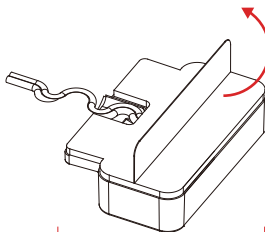

2-3/8" (60mm)

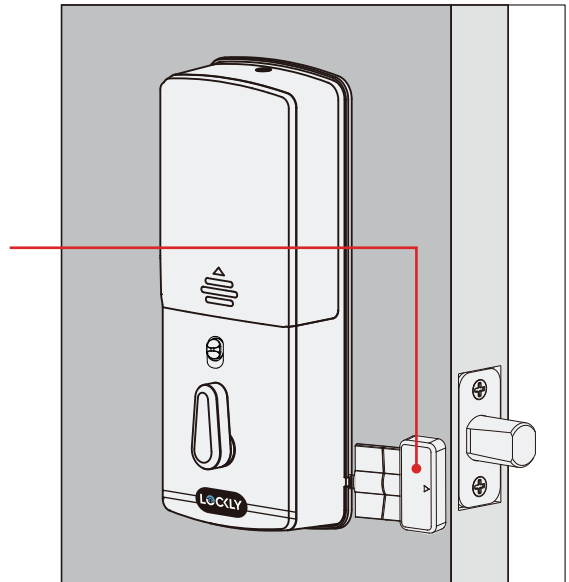

DOOR FRAME SENSOR (Q)

Manually retract deadbolt and close door. Dry fit sensor **Q** to door frame and check for alignment. If needed, raise the height of the sensor to be more level with sensor **P** by adding 1 or 2 of the included adhesive foam pads. Once satisfied both sensors are as level as possible, remove film from adhesive and install with arrows aligned to each other with less than a 3/4" gap between each sensor.

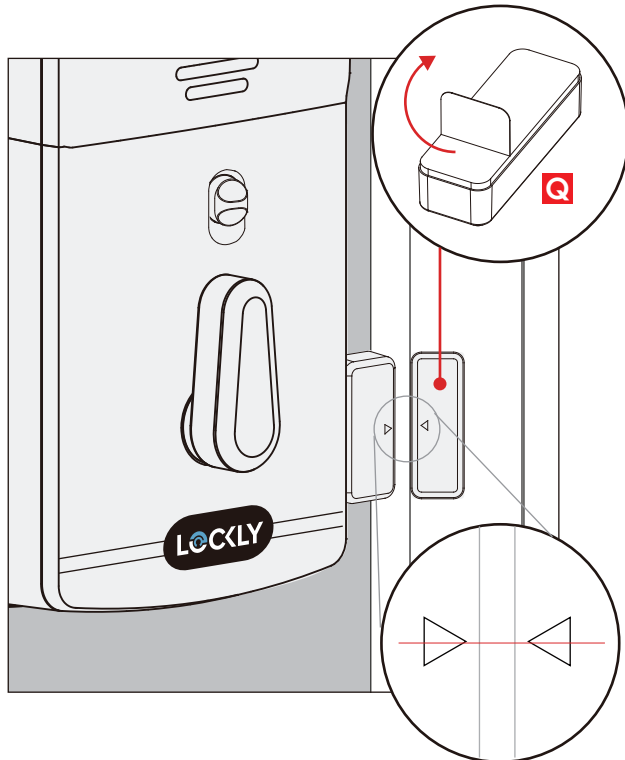

When properly installed, the Lockly logo blinks red when door opens and closes.

Step 7

INSTALLING DOOR STRIKE

Use the supplied door strike or use your existing as long as deadbolt operates smoothly without binding or catching.

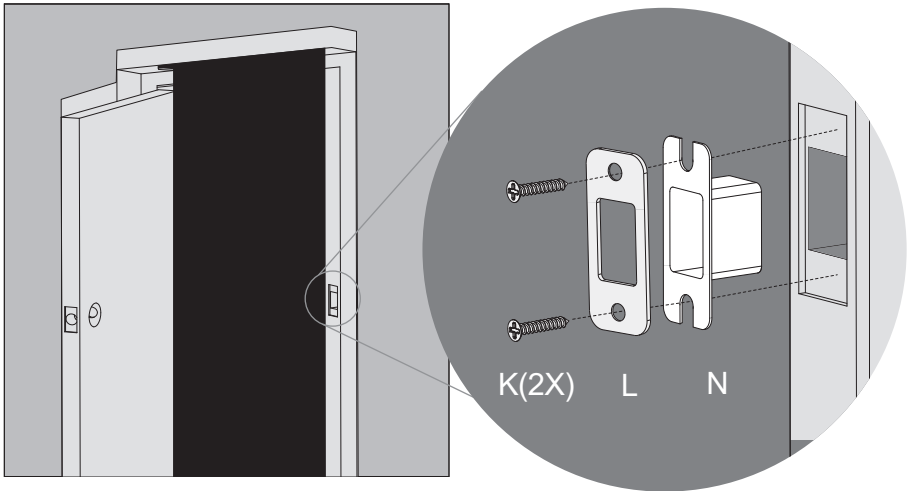

IMPORTANT: Because doors and frames vary in design, it may be necessary to make slight adjustments to your strike plate and/or dust box in order to ensure smooth deadbolt operation. **This is very important.** If the deadbolt is binding or catching in any way the lock will sound an alarm (rapid beeping) indicating it cannot close due to misalignment and/or excessive rubbing or binding.

You have completed the Lockly physical lock installation. To enable live monitoring and voice control with Hey Google or Amazon Alexa, you will need to setup the included Secure Link Wi-Fi hub and pair it with the Lockly Access Touch Pro fingerprint deadbolt smart lock and door sensor.

Before connecting Secure Link Wi-Fi hub, download the Lockly app on your smartphone. It is required to finish setup and to pair the connection between hub and lock.

**Scan or visit
Lockly.com/app**

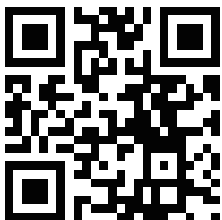

**or
Search & Download
directly on...**



To set up your Lockly Access Touch Pro, choose an appropriate location for the Secure Link Wi-fi Hub for optimum performance (see below). For optimum connectivity, it is recommended that the hub be no further away from the lock than 30 feet (9 meters).

During the setup process position yourself between the lock and the Secure Link Wi-Fi Hub—ideally no more than 30 feet (9 meters) apart. Ensure your iOS or Android device has both Bluetooth and Wi-Fi enabled.

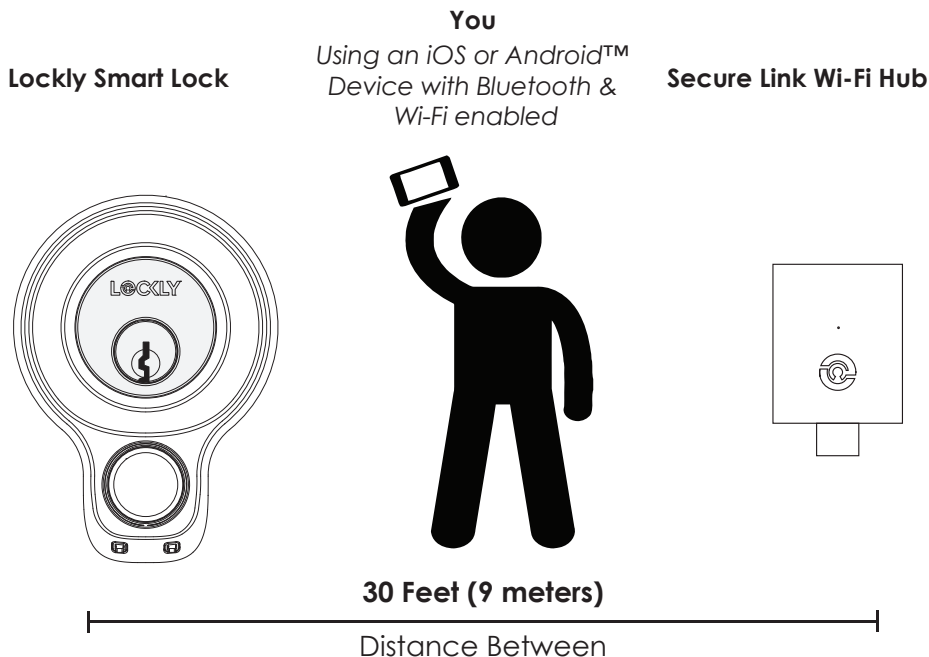

TIP: The Secure Link requires a strong wireless signal for optimal performance. Make sure the Secure Link will be installed in a location with a strong 2.4 Ghz wireless signal. Sometimes distances between Wi-Fi hub and lock can vary due to circumstances. If you are having difficulty setting up optimal range of 30/ft or less, we're here to help. Call our customer care team: (669) 500 8835, or visit [Lockly.com/help](https://www.lockly.com/help) for suggestions and troubleshooting tips.

Plug the Secure Link Wi-Fi Hub into the 5V 1A USB AC adapter and plug the AC adapter to your wall socket.



USA Outlet Shown

A **GREEN** LED indicator light will flash slowly to indicate that the Wi-Fi Hub is ready to connect.



LED Indicator is located next to the Setup Button

Once you have confirmed that your Secure Link Wi-Fi Hub is ready to connect to your lock, open the Lockly App from your smartphone. **Make sure you are standing between the Wi-Fi hub and Lockly smart lock**, then **Add New Device** and follow the on screen instructions.

The App will take you through the following steps, make sure the smart lock has been properly installed. You will need your activation card that is included in the box to proceed.

ADD NEW DEVICE

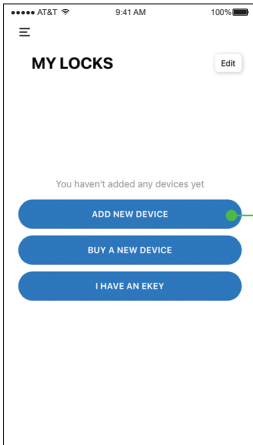

Select A Device

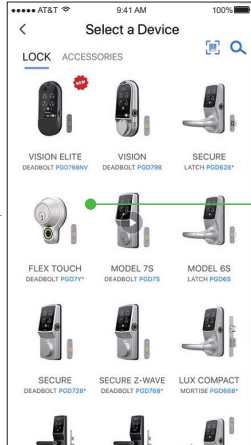

Scanning LOCK SERIAL

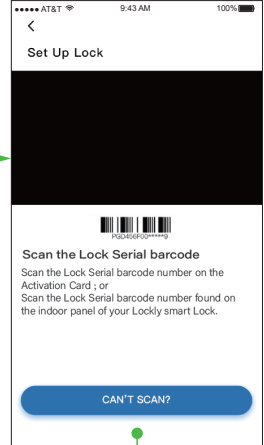

Input Activation Code

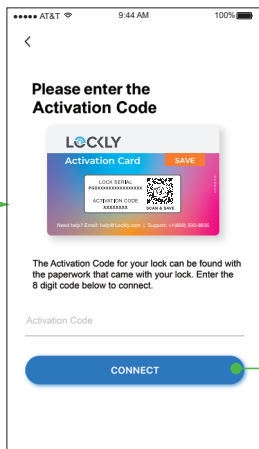

Plug in your Secure Link and Click "YES"

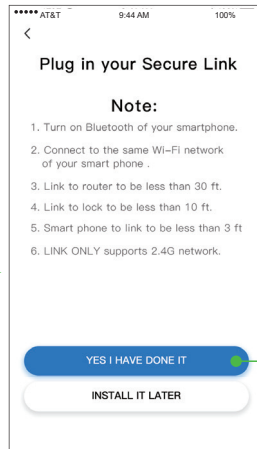

Turn to the next page

Set Wi-Fi

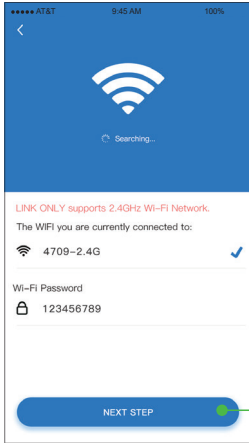

Green light is on Click "Yes" when the

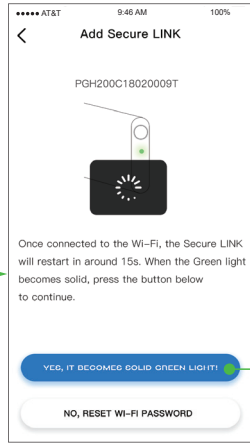

Select lock Bluetooth

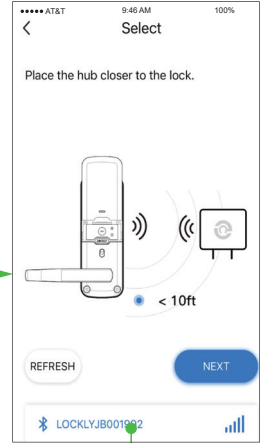

Successfully Added

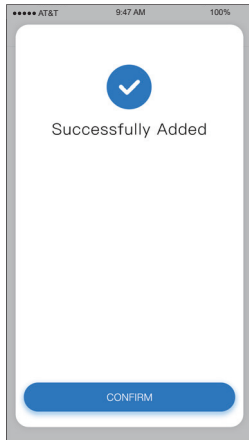

Congratulations!
Your Lockly Access
Touch Pro is now set
up.

You may proceed to
Add the Door Sensors.

Hands-free voice control

Control and check your status using only your voice with Amazon Alexa or Google Assistant-enabled devices.



"Alexa, is my Front Door locked?"



"Your Front Door is locked"

To setup your lock to work with either voice assistant, download the Amazon Alexa or Google Home App and add a new Amazon Alexa Skill or Lockly Action on Google.



TIP: In Google Home or Amazon Alexa app, add Lockly skill for Alexa or Lockly Action on Google, then follow on screen instructions. See full list of commands, help videos, or troubleshooting your Lockly at <https://Lockly.com/help>

Google, Android, Google Play and Google Home are trademarks of Google LLC.

Adding wireless door/window sensor is optional. For extra peace of mind we have included a wireless sensor you can use to replace the pre-wired sensor or use it for another door or even for a window. We recommend installing this sensor as it provides the ability to verify that your door or window is securely closed and it also sends push notifications to your phone on the status of your door or window when someone opens and closes the it.

It is simple and very easy to install anywhere and it only uses AAA battery for long and optimal operation.

This sensor comes in two parts. Depending on your door or window orientation, the sensor can be mounted in different ways.

Part 1 - Door Frame Sensor

Part 2 - Door Sensor Magnet

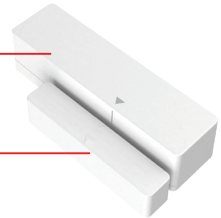

Preparation

Make sure you install the Sensor indoors on a clean and dry surface. Gently wipe the surface of your door or window and door or window frame where you wish to install the Sensor and make sure it's dry before installing. **DO NOT INSTALL YET.**

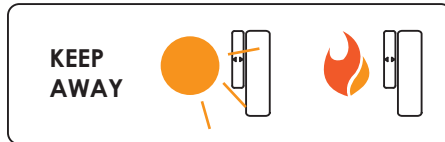

Keep the Sensor away from direct sunlight, high heat locations and large metal objects that may interfere with wireless signals.

The optimal location to install the Sensor is on the upper corners of your door or window, away from the reach of children and pets.

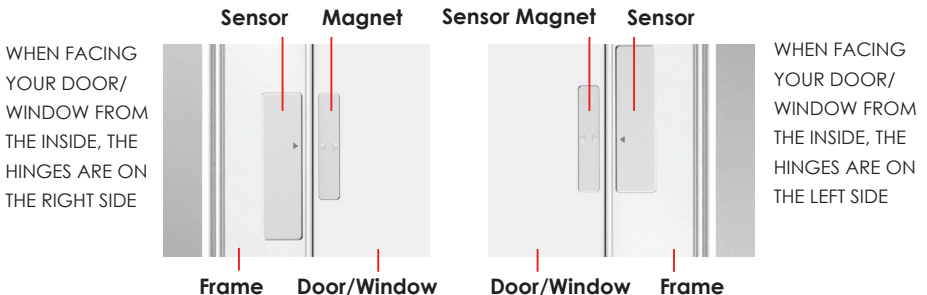

When you are installing the Sensor, make sure the arrows on the Sensor is placed next to the arrow of the Sensormagnet.

Gap - less than 3/4" when installed.

When installed on your door or window, the distance between the Sensor and the Sensor magnet must be less than 3/4" in order for the sensor to work.

Install the battery

Open the sensor as shown, put in 1 AAA battery, please pay attention to the positive and negative poles of the battery.

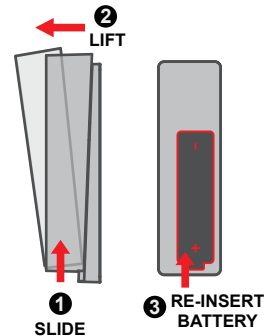
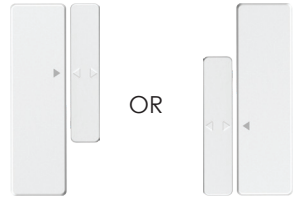

Pairing Security Sensor

The wireless Security Sensor is pre-paired with the smart lock and you do not need to manually pair it. If you have replaced or deleted the sensor, you will need to pair it again following these steps:

In the Lockly App, go to Settings>Secure Link/ Sensor, then select "Add new sensor", then "Add Wireless Sensor". Lockly continuously optimizes user experience, please follow the actual screen instructions on the app.

After pairing, you can customize the name of the sensor. To test if the sensor is working, align the arrows of the sensor and magnet sensor. The sensor will blink blue. Then separate the magnet away from the sensor, you will receive an App notification that door/window (or your customized name for the sensor) is unlocked. The security sensor can be used even for cabinets, drawers, refrigerators, sliding doors/windows and other areas of your home that requires monitoring of opening and closing.

IMPORTANT: (1) Do not allow the battery to corrode or leak as this may cause permanent damage to the product. (2) Make sure to insert battery on correct polarity as shown inside the battery compartments. (3) Do not use rechargeable batteries. (4) When battery is drained, do not dispose with normal household waste. Dispose via suitable recycling center. DO NOT BURN.

FCC Warning :

This device complies with Part 15 of the FCC Rules. Operation is subject to the following two conditions: (1) This device may not cause harmful interference, and (2) this device must accept any interference received, including interference that may cause undesired operation.

NOTE 1: This equipment has been tested and found to comply with the limits for a Class B digital device, pursuant to part 15 of the FCC Rules. These limits are designed to provide reasonable protection against harmful interference in a residential installation. This equipment generates, uses and can radiate radio frequency energy and, if not installed and used in accordance with the instructions, may cause harmful interference to radio communications. However, there is no guarantee that interference will not occur in a particular installation. If this equipment does cause harmful interference to radio or television reception, which can be determined by turning the equipment off and on, the user is encouraged to try to correct the interference by one or more of the following measures:

- Reorient or relocate the receiving antenna.
- Increase the separation between the equipment and receiver.
- Connect the equipment into an outlet on a circuit different from that to which the receiver is connected.
- Consult the dealer or an experienced radio/TV technician for help.

NOTE 2: Any changes or modifications to this unit not expressly approved by the party responsible for compliance could void the user's authority to operate the equipment.

FCC Radiation Exposure Statement

This equipment complies with FCC radiation exposure limits set forth for an uncontrolled environment. It should be installed and operated with minimum distance 20cm between the radiator & your body.

IC WARNING

This device contains license-exempt transmitter(s) that comply with Innovation, Science and Economic Development Canada's licence-exempt RSS(s). Operation is subject to the following two conditions:

- (1) This device may not cause interference.
- (2) This device must accept any interference, including interference that may cause undesired operation of the device.

L'émetteur/récepteur exempt de licence contenu dans le présent appareil est conforme aux CNR d'Innovation, Sciences et Développement économique Canada applicables aux appareils radio exempts de licence. L'exploitation est autorisée aux deux conditions suivantes:

1. L'appareil ne doit pas produire de brouillage;
2. L'appareil doit accepter tout brouillage radioélectrique subi, même si le brouillage est susceptible d'en compromettre le fonctionnement.

IC Radiation Exposure Statement

This equipment meets the exemption from the routine evaluation limits in section 2.5 of RSS-102. It should be installed and operated with a minimum distance of 20cm between the radiator and any part of your body.

Cet équipement est conforme à l'exemption des limites d'évaluation habituelle de la section 2.5 de la norme RSS-102. Il doit être installé et utilisé à une distance minimale de 20 cm entre le radiateur et toute partie de votre corps.



WARNING: This product can expose you to chemicals including Lead, which is known to the State of California to cause cancer. For more information go to www.P65Warnings.ca.gov.

For the latest version of this manual, please visit the following link: **[Lockly.com/help](https://www.lockly.com/help)**

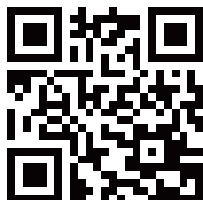

We're here to help!
help@lockly.com

To ensure you have access to the most updated and newly added features of your Lockly smart lock, please visit:
[www.Lockly.com/newfeatures](https://www.lockly.com/newfeatures)

INSTALLATION OVERVIEW AND PARTS LIST

Parts List

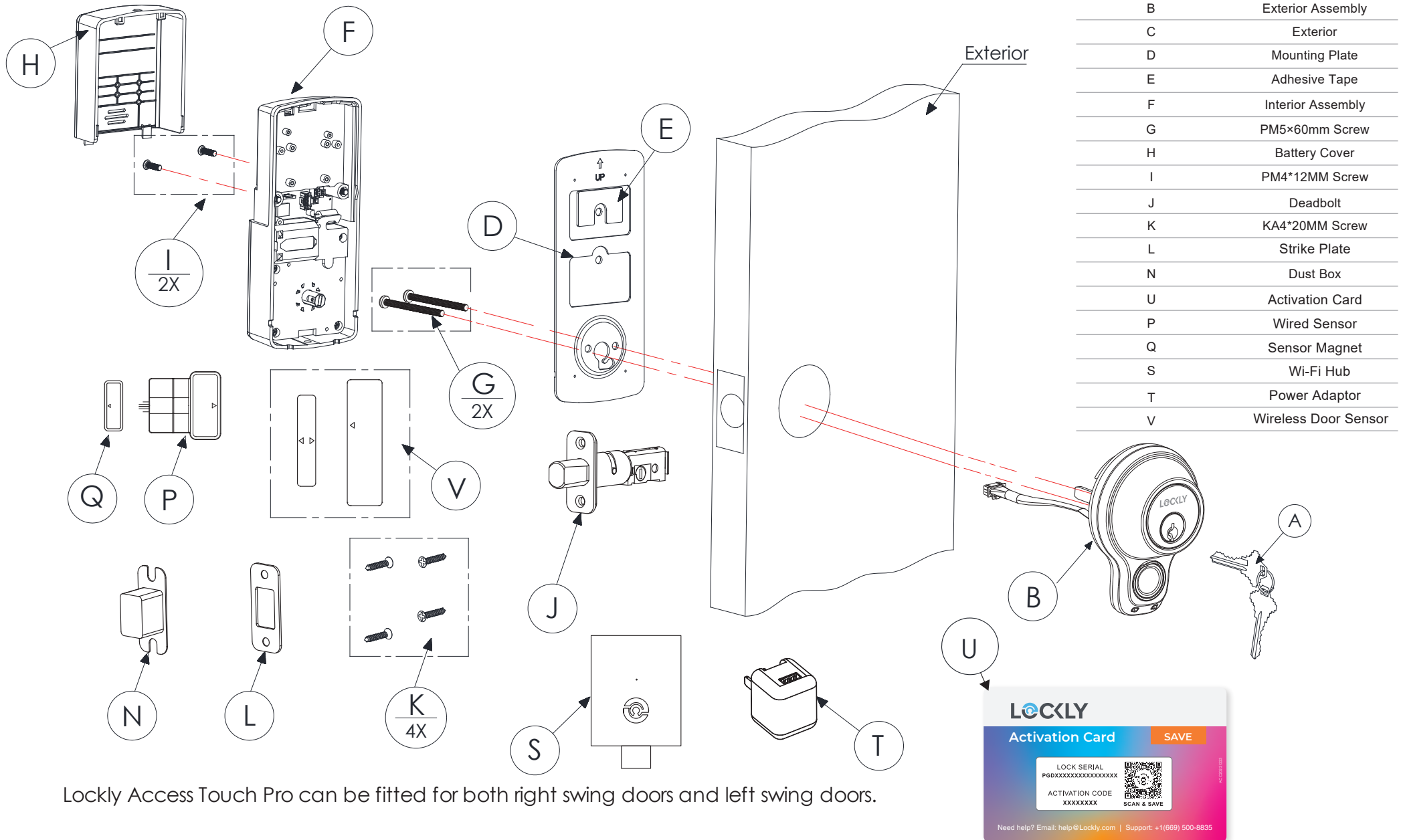

Lockly Access Touch Pro can be fitted for both right swing doors and left swing doors.

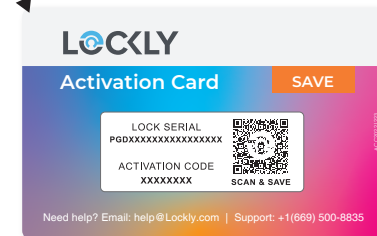

LOCKLY ACCESS TOUCH PRO

To download the latest digital copy of installation guide, user manual and/or watch instructional videos, go to [Lockly.com/installation](https://lockly.com/installation).



LOCKLY ACCESS TOUCH PRO

For the latest version of this manual, please visit the following link:

[Lockly.com/help](https://lockly.com/help)

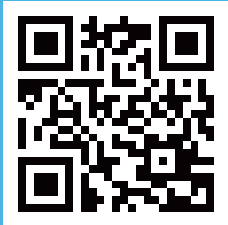

We're here to help!
help@lockly.com

© Copyright 2023 Lockly All rights reserved

USA Patent No. US 9,881,146 B2 | USA Patent No. US 9,853,815 B2 | USA Patent No. US 9,875,350 B2 | USA Patent No. US 9,665,706 B2 | USA Patent No. US 11,010,463 B2 | AUS Patent No. 2013403169 | AUS Patent No. 2014391959 | AUS Patent No. 2016412123 | UK Patent No. EP3059689B1 | UK Patent No. EP3176722B1 | AUS Patent NO.202114326 | USA Patent Application No.29/802,162

The Bluetooth® word mark and logos are registered trademarks owned by the Bluetooth SIG, Inc. , and any use of such marks by Lockly is under license. Other trademarks and trade names are those of their respective owners. Google, Android, Google Play and Google Home are trademarks of Google LLC. , Amazon, Alexa and all related logos are trademarks of Amazon.com, Inc., or its affiliates.

IMPGD7YW20230209