

HARMSCO®

Filtration Products

An American Business Success...



HARMSCO® Filtration Products

Providing Liquid Filtration Solutions

The Harmsco® Story

Inventor John Harms and his wife Laura founded Harmsco, Inc. in 1958. Their mission was to design and manufacture high quality filtration equipment and market their product line worldwide. Over 50 years later, Harmsco® brand



West Palm Beach corporate headquarters and plant



Lake Wales plant

filtration products are recognized around the globe and respected by the leading experts in the filtration industry. With over 180,000 square feet of manufacturing space in West Palm Beach and Lake Wales, Florida, Harmsco® is prepared to meet the ever increasing global demands for liquid filtration.



Why Harmsco®

- ▶ **UP-FLOW DESIGN** - Harmsco HIF, BC, WB, HP and SB filter housings utilize Up-Flow design which eliminates air entrapment in the filter housing as well as potential for by-pass of contaminate downstream.
- ▶ **HURRICANE® FILTER HOUSINGS** - Hurricane® filters provide unsurpassed performance. They separate dense solids prior to cartridge filtration for extended filter life, increased dirt holding capacity and reduced maintenance costs.
- ▶ **PLEATED CARTRIDGES** - Pleated cartridges offer more surface area for longer life, increased solids removal and reduced operation costs. Harmsco offers more cartridge lengths and micron sizes than any other supplier.
- ▶ **ELECTROPOLISHED FINISH** - Harmsco offers an electropolished finish as STANDARD on HIF, BC, WB, HP, SB, FSSS and BCB filter housings. All stainless steel components are electropolished for a superior finish and increased durability.
- ▶ **NSF LISTED PRODUCTS** - Harmsco offers a complete line of filter cartridges and housings which are manufactured with FDA listed materials and are NSF-61 Listed for public drinking water use.
- ▶ **QUALITY ASSURANCE** - All Harmsco products are tested and validated to assure the highest quality standards.

Key Markets

Chemical Processing
Desalination
Environmental Compliance
Food & Beverage
Heat Transfer
Irrigation Water
Metal Working Fluids

Mining
Municipal Drinking Water
Paints & Dyes
Petrochemical
Petroleum
Pharmaceutical
Pulp & Paper

Residential Water
Surface Water
Utilities
Waste Water Treatment
Water Conditioning
Water Treatment
Well Water



Liquid Filtration Solutions



Patented Up-Flow Filtration Process

CONVENTIONAL CARTRIDGE FILTER DESIGN

Potential For Air Entrapment

With outlets located **below** inlets, air travels upward so vents are needed to expel air that can accumulate within the filter vessel during operation.

Potential For By-Pass

With outlets located **below** inlets, by-pass can occur as unfiltered liquid drains downward to the sump while the cartridges are removed. This may result in by-pass when the filter is put back into service.

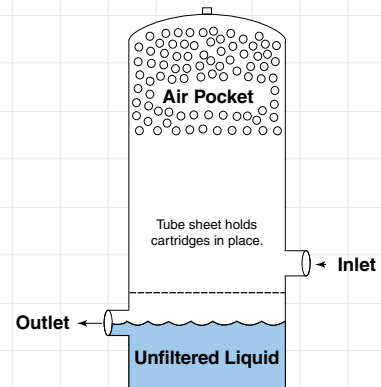

HARMSCO® UP-FLOW CARTRIDGE FILTER

No Air Entrapment

Air is self purged from Harmsco® Up-Flow filters because outlets (top of standpipes) are at the high point of the filters.

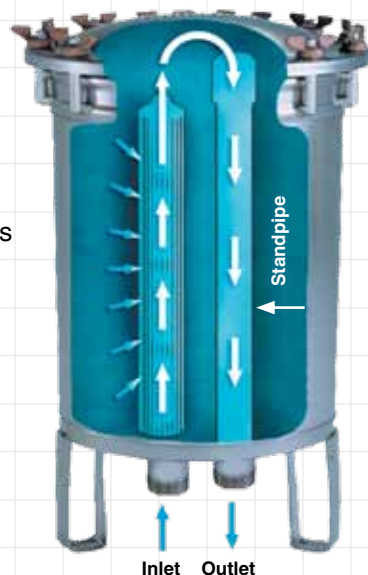

No By-Pass During Service

No liquid can by-pass Harmsco® filters during servicing because standpipes are the "clean side" of the filter.

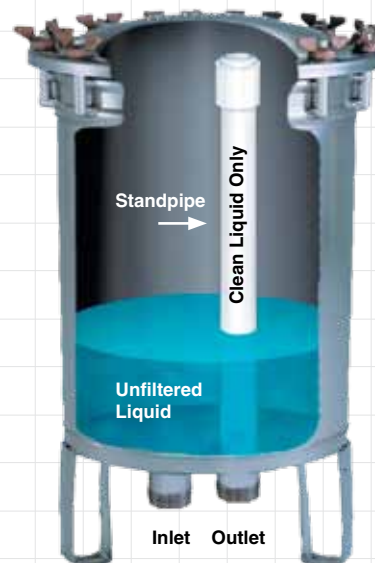

HARMSCO® Hurricane®

The Revolutionary Filter!



Single Hurricane® Cartridge

Easy to install, remove, clean and replace!

Tangential Entry

Liquid enters the filter tangentially to provide rotational flow and centrifugal force for particle separation.

Outer Chamber for Particle Separation

Centrifugal separation occurs in the filter's outer chamber by rotational flow and centrifugal force. Heavy solids accumulate at the bottom of the filter's outer chamber which may be purged manually or automatically.

Inner Chamber for Cartridge Filtration

Liquid flows from the outer chamber into an inner chamber where the single cartridge is located. Here, the liquid is filtered and subsequently flows out of the filter through the standpipe and outlet fitting.

Rotational Flow Pattern

Continuously "fluffs" filter cake to increase dirt and debris holding capacity to extend filter life and time between cleaning.

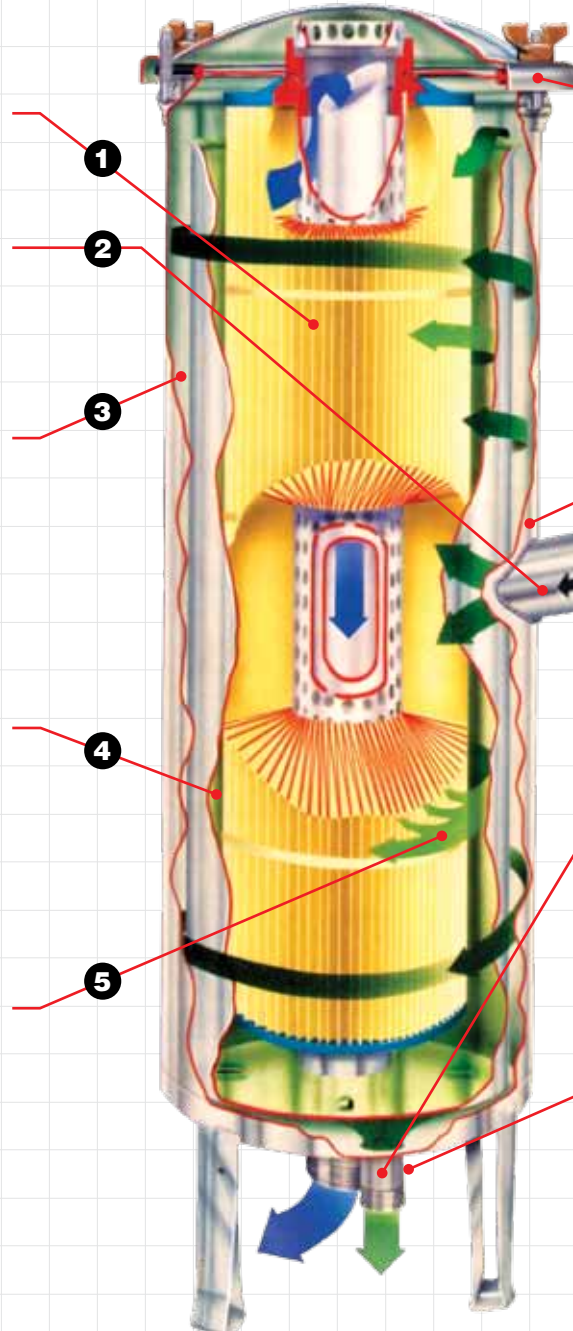

Fail-safe Lid with Wing Nuts for Easy Closure

Lids come standard with wing nuts for easy operation without tools. Individual studs provide added security. No single-bolt v-clamp closures are used.

Note: hex nuts are recommended above 100 psi pressures, tightened to 75 inch lbs. of torque for best results.

304 Electropolished Stainless Steel

Solid, stainless steel construction and electropolishing are standard for added resistance to corrosion. *Note: special coatings available for chemical resistance.*

Drain for Manual or Automatic Purge

In heavy solids applications, manual or automatic valves may be used to purge solids from the outer chamber to extend filter life (valves not provided by Harmsco). Tests demonstrate approximately half of the heavy solids, such as sand, separate prior to the filtration chamber at 50 GPM.

Couplers for Pressure Gauges Provided

1/4" FPT couplers are installed in inlet and outlet fittings for pressure gauges.



Hurricane® SB Series

(L to R) HUR 1x170FL, HUR 5x170FL, HUR 3x170FL, HUR 8x170FL



Certified to ANSI-NSF 61



Hurricane® HP Series

(L to R) HUR 40 HP, HUR 170 HP, HUR 90 HP

Note: This publication is to be used as a guide. The data within has been obtained from many sources and is considered to be accurate. Harmsco does not assume liability for the accuracy and/or completeness of this data. Changes to the data can be made without notification. Temperature, Pressure, Flow Rates, Differential Pressures, Chemical Combinations and other unknown factors can affect performance in unknown ways. **Limited Warranty:** Harmsco warrants their products to be free of material and workmanship defects. Determination of suitability of Harmsco products for uses and applications contemplated by Buyer shall be the sole responsibility of Buyer. The end user/installer/buyer shall be liable for the product's performance and suitability regarding their specific intended applications. End users should perform their own tests to determine suitability for each application.

Here's Proof!

HARMSCO® Filters Save Money

Laboratory test using AC Coarse Test Dust shows HARMSCO® pleated filter cartridges save money because they:

- ▶ Remove more solids
- ▶ Filter longer
- ▶ Can be cleaned and reused in most applications

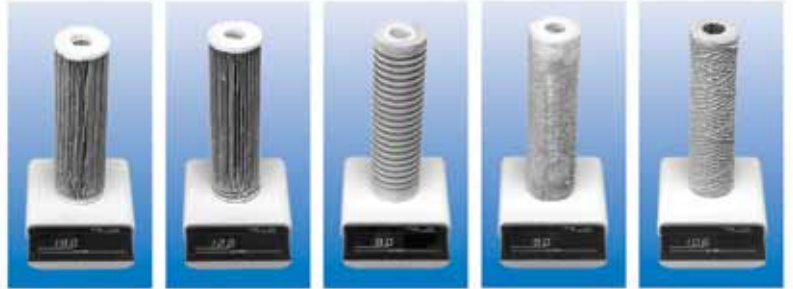

Test Summary:

	Harmsco® 801	Harmsco® WaterBetter®	Resin Bonded Cellulose	Spun Polypropylene	String Wound
Solids Removed (oz.)	12.0	7.0	3.3	2.5	2.1
Elapsed Time (minutes to achieve 30 psiΔp)	16.8	11.08	2.8	1.97	1.33
Cleanable & Reusable	Yes	Yes	No	No	No

Tests conducted with coarse test dust and 3% solids using 5 micron cartridges. Filtration was terminated when each cartridge reached its capacity and experienced a 30 psi pressure differential. Cartridges were weighed prior to and after filtration tests to determine solids removed.

More Filter Media For Longer Life

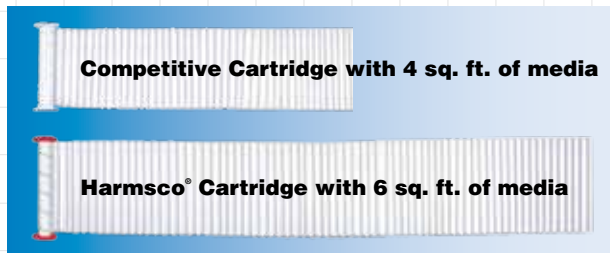

More media provides longer filter life and reduced costs because fewer replacement cartridges are required.

Superior Construction



Competitive Cartridge **Harmsco® Cartridge 801 Series**

Our center tubes and ends are thermally bonded for added strength to provide superior end sealing and improved performance.

Cleanable and Reusable



Harmsco® cartridges cost less to use, regardless of what they cost to buy.

Color Coded End Caps



Standard cartridges have color coded end caps to identify the micron rating.

Note: This publication is to be used as a guide. The data within has been obtained from many sources and is considered to be accurate. Harmsco does not assume liability for the accuracy and/or completeness of this data. Changes to the data can be made without notification. Temperature, Pressure, Flow Rates, Differential Pressures, Chemical Combinations and other unknown factors can affect performance in unknown ways. **Limited Warranty:** Harmsco warrants their products to be free of material and workmanship defects. Determination of suitability of Harmsco products for uses and applications contemplated by Buyer shall be the sole responsibility of Buyer. The end user/installer/buyer shall be liable for the product's performance and suitability regarding their specific intended applications. End users should perform their own tests to determine suitability for each application.

NSF Listed Products

FILTER HOUSINGS

Tab 1

Hurricane® SB and HP
Filter Housings

Tab 2

WaterBetter® WB
Filter Housings

Tab 4

HIF
Filter Housings



The Public Health and Safety Company™

FILTER CARTRIDGES

Tab 21

Hurricane® Polyester and
Hurricane® Harmsco-Free Cartridges

Tab 22

Premium and WaterBetter®
Cartridges

Tab 23

701 Series Cartridges

Tab 24

Calypso Blue™ Cartridges

Tab 26

Poly-Pleat™ Cartridges

Tab 27

HAC and WaterBetter®
Carbon Cartridges

Filter Housing Selection Guide

Tab 1

SB and HP Hurricane® Housings Industrial/Municipal (SB) Commercial (HP)

- ▶ Combination cyclone separator and cartridge filter in a single design
- ▶ Patented Up-flow design
- ▶ Flow rates to 1,200 GPM (SB) and to 150 GPM (HP)

NSF NSF-61 Listed

[View Hurricane® Animation](http://www.youtube.com/watch?v=tOXGsUnhmW4)
www.youtube.com/watch?v=tOXGsUnhmW4



Tab 2

WB and WB 5x170FL WaterBetter® Housings Commercial

- ▶ Single cartridge design
- ▶ Patented Up-flow design
- ▶ Coated option available
- ▶ Flow rates to 150 GPM (WB) and to 600 GPM (WB 5x170FL)
- ▶ Offered in 304/316 stainless steel

NSF NSF-61 Listed (excluding WB 5x170FL)



Tab 3

HMC Filter Housings Industrial/Municipal

- ▶ Built to ASME design standards
- ▶ U-Stamp option available
- ▶ Standard hold down plates to accept DOE, 222/Flat and 222/Fin style cartridges
- ▶ Flow rates to 1,400 GPM
- ▶ Offered in 304/316 stainless steel



Tab 4

HIF Filter Housings Commercial

- ▶ Patented Up-flow design
- ▶ Coated option available
- ▶ Flow rates to 800 GPM
- ▶ Offered in 304/316 stainless steel

NSF NSF-61 Listed



Tab 5

BC and HBC Band Clamp Housings Commercial

- ▶ FNPT, BSTP, Flange and Victaulic connections available (BC series only)
- ▶ Patented Up-flow design (BC series only)
- ▶ Flow rates to 600 GPM
- ▶ Offered in 304/316 stainless steel



Tab 6

FSSS Single Cartridge Housings Commercial/Industrial

- ▶ Designed for 300 PSI
- ▶ DOE or 222/Flat configurations available
- ▶ Offered in 304/316 stainless steel



Tab 7

HMB, HSB and BCB Bag Housings Industrial/Municipal

- ▶ U-Stamp option available (HMB, HSB)
- ▶ Standard #1, #2 and Extended bag options
- ▶ Flow rates to 2,400 GPM
- ▶ Offered in 304/316 stainless steel



Tab 8

Filtration Systems



Tab 9

Specialty Housings



Tab 10

NSF Listed Filter Housings



Note: This publication is to be used as a guide. The data within has been obtained from many sources and is considered to be accurate. Harmsco does not assume liability for the accuracy and/or completeness of this data. Changes to the data can be made without notification. Temperature, Pressure, Flow Rates, Differential Pressures, Chemical Combinations and other unknown factors can affect performance in unknown ways. **Limited Warranty:** Harmsco warrants their products to be free of material and workmanship defects. Determination of suitability of Harmsco products for uses and applications contemplated by Buyer shall be the sole responsibility of Buyer. The end user/installer/buyer shall be liable for the product's performance and suitability regarding their specific intended applications. End users should perform their own tests to determine suitability for each application.

Filter Housings – Tab 1

SB and HP Hurricane® Housings

SB Hurricane® Housings

- ▶ Combination cyclone separator and cartridge filter in a single design
- ▶ Patented Up-flow design
- ▶ Coated option available
- ▶ Flow rates up to 1,200 GPM
- ▶ Offered in 304 and 316 stainless steel



HP Hurricane® Housings

- ▶ Combination cyclone separator and cartridge filter in a single design
- ▶ Patented Up-flow design
- ▶ Coated option available
- ▶ Flow rates up to 150 GPM
- ▶ Offered in 304 and 316 stainless steel



Sizing Info:

SB Hurricane® and HP Hurricane® housings accept 7-3/4" O.D. cartridges.

Cartridge Options

Hurricane® Cartridges

(Tab 21)

- ▶ High flow, high surface area
- ▶ Low initial pressure drop provides longer filter life
- ▶ NSF-61 Listed cartridges available
- ▶ High Temperature cartridges available
- ▶ Lowest cost per filtered gallon based on surface area

SureSafe™ Cartridges

(Tab 25)

- ▶ Antimicrobial cartridge media prohibits growth of bacteria and mold on filter cartridge
- ▶ Offered in 20 and 50 micron ratings and a wide range of cartridge sizes
- ▶ Agion Silver Zeolite is FDA tested and registered with the EPA

Premium Poly-Pleat™ Cartridges

(Tab 26)

- ▶ Pleated one micron absolute cartridges for safe, cyst-free drinking water
- ▶ NSF-61 Listed
- ▶ Available in a wide range of cartridge sizes

Carbon Cartridges

(Tab 27)

- ▶ For high chlorine, taste, odor, lead, THM and organic chemical removal
- ▶ Available in a wide range of cartridge sizes, including Hurricane® 170 Series
- ▶ NSF-42 Listed

All-Poly/High Purity Cartridges

(Tab 28)

- ▶ Available in Hurricane® sizes 40, 90 and 170, and in micron ratings 0.2, 0.45, 1, 5, 10, 20 and 50

High-Temp Cartridges

(Tab 29)

- ▶ Pleated design; high flow capacity
- ▶ Two temperature ratings (200°F/93°C and 250°F/121°C)
- ▶ Available in Hurricane® only

Note: This publication is to be used as a guide. The data within has been obtained from many sources and is considered to be accurate. Harmsco does not assume liability for the accuracy and/or completeness of this data. Changes to the data can be made without notification. Temperature, Pressure, Flow Rates, Differential Pressures, Chemical Combinations and other unknown factors can affect performance in unknown ways. **Limited Warranty:** Harmsco warrants their products to be free of material and workmanship defects. Determination of suitability of Harmsco products for uses and applications contemplated by Buyer shall be the sole responsibility of Buyer. The end user/installer/buyer shall be liable for the product's performance and suitability regarding their specific intended applications. End users should perform their own tests to determine suitability for each application.

Hurricane® Swing Bolt Housings

Two Technologies in One

Lower Operation Cost

- Harmsco® Hurricane® Swing Bolt filter housings provide unsurpassed performance. Their unique design separates dense solids prior to cartridge filtration for extended filter life, increased dirt holding capacity and reduced maintenance costs.



Certified to
ANSI-NSF 61

Features

- ▶ Patented Up-flow Design
- ▶ NSF 61 listed
- ▶ Electro-polished finish - standard
- ▶ "Swing Bolt" closure system
- ▶ Combination cyclone separator and cartridge filter in a single compact design
- ▶ Four sizes for greater utility - one, three, five and eight cartridges
- ▶ 304 stainless steel housing and internal components - standard
- ▶ The industry's largest selection of cartridge options
- ▶ Built to ASME design standards
- ▶ Coated option available
- ▶ Flow rates up to 1,200 GPM



Applications

- ▶ Municipal Drinking Water
- ▶ Cooling Tower Filtration
- ▶ Desalination Pre-filtration (coated option)
- ▶ Surface Water Treatment Rule (SWTR) LT2
- ▶ Industrial Waste Water Treatment
- ▶ Reverse Osmosis Pre-filtration
- ▶ Ground Water Remediation
- ▶ Ground Water Under Direct Influence (GUDI)



Cartridge Sizing Guide

For Harmsco® Hurricane® Swing Bolt Single and Multiple Cartridge Filter Housings

Harmsco® recommends operation at 70% of maximum flow rate for optimum performance.

Polyester-Plus™, High Temp, Harmsco-Free, SureSafe™, EZ Clean, Poly-Mesh

Filter Model	NO. of Cartridges	Pleated Media Area (sq.ft.)	Length (in.)	O.D. (in.)	Recommended Flow Rate* (GPM)	Max Flow Rate (GPM)	Max Flow Rate (LPM)	Max Flow Rate (M³/HR)	Carton Size
HUR 1x170FL	1	170	30-3/4	7-3/4	105	150	568	34	9x9x32
HUR 3x170FL	3	510	30-3/4	7-3/4	315	450	1,703	102	9x9x32
HUR 5x170FL	5	850	30-3/4	7-3/4	525	750	2,839	170	9x9x32
HUR 8x170FL	8	1360	30-3/4	7-3/4	840	1200	4,542	272	9x9x32

Poly-Pleat™

HUR 1x170FL	1	100	30-3/4	7-3/4	50	–	–	–	9x9x32
HUR 3x170FL	3	300	30-3/4	7-3/4	150	–	–	–	9x9x32
HUR 5x170FL	5	500	30-3/4	7-3/4	250	–	–	–	9x9x32
HUR 8x170FL	8	800	30-3/4	7-3/4	400	–	–	–	9x9x32

All-Poly

HUR 1x170FL	1	75	30-3/4	7-3/4	60*	100	76	36	9x9x32
HUR 3x170FL	3	225	30-3/4	7-3/4	180*	300	228	108	9x9x32
HUR 5x170FL	5	375	30-3/4	7-3/4	300*	500	380	180	9x9x32
HUR 8x170FL	8	600	30-3/4	7-3/4	480*	800	608	288	9x9x32

Carbon Block

*based on 1, 5, 10, 20 and 50 micron ratings

HUR 1x170FL	1	90	30-3/4	7-3/4	15**	–	–	–	9x9x32
HUR 3x170FL	3	270	30-3/4	7-3/4	45**	–	–	–	9x9x32
HUR 5x170FL	5	450	30-3/4	7-3/4	75**	–	–	–	9x9x32
HUR 8x170FL	8	720	30-3/4	7-3/4	120**	–	–	–	9x9x32

**recommended flow for maximum chlorine removal



Hurricane® Cartridge
Length and O.D.

Cleanable/Reusable

Hurricane® cartridges are cleanable and reusable in most applications and micron ratings (5 micron and up).

SureSafe™

(antimicrobial)

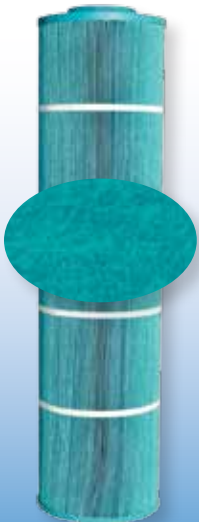

Carbon Block

(5 Micron Pleated Pre-filter)

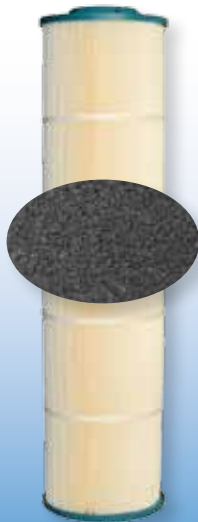

EZ Clean



Poly-Mesh

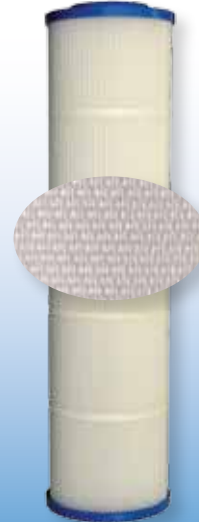

cartridges in the industry for all your filtration needs.

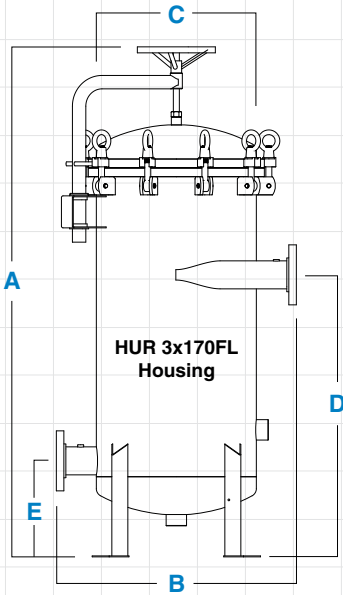

Ordering Information

Filter Model	A Filter Height	B Width	C Diameter	D Inlet	E Outlet	Pipe Size I/O NPS	Drain Size NPT	Floor Space	Service Height	Shipping Wt. (lbs.)
HUR 1x170FL	48"	15-1/2"	11"	23-5/8"	9-3/4"	2" Flange	3/4"	1.8 ft ²	77"	150
HUR 3x170FL	64"	30"	20"	35-1/4"	12"	3" Flange	1-1/2"	3.7 ft ²	98-1/2"	420
HUR 5x170FL	74"	37-1/2"	30"	38"	14-1/8"	4" Flange	1-1/2"	7.6 ft ²	98-1/2"	1,100
HUR 8x170FL	84"	44-1/4"	35-3/8"	44-1/4"	20-1/2"	6" Flange	1-1/2"	13 ft ²	98-1/2"	1,600

Filter Specifications

- ▶ Electropolished finish
- ▶ Built to ASME design standards
- ▶ Standpipes - stainless steel
- ▶ Inlet/Outlet - flanged connections
- ▶ O-ring housing seal, swing-bolt closure
- ▶ Pressure - Up to 150 psi (10 bar) max.
- ▶ Temperature - Up to 140°F (60°C)* with standard cartridges. *Up to 200°F (93°C) with HT, and 250°F (121°C) with HTM high temperature cartridges.

Pressure Drop

Pressure Drop vs. Flow Rate

The total head loss data shown indicates pressure drop with Hurricane® Swing Bolt filter housings and 20-micron filter cartridges in clean water.

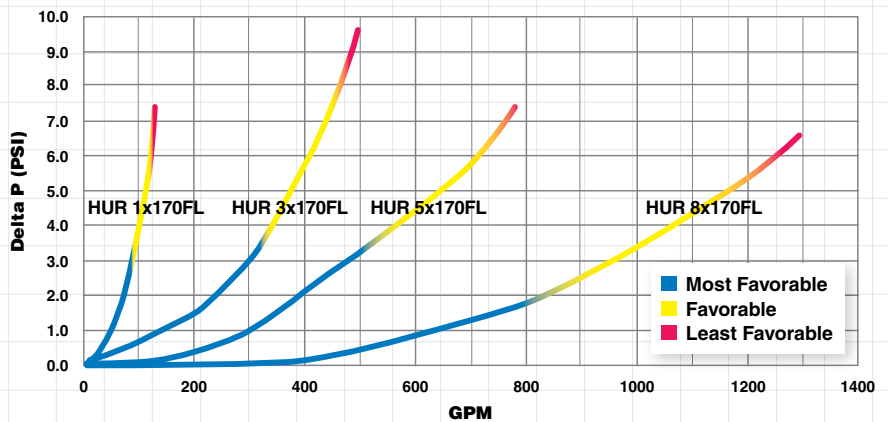

For additional information, please refer to the "Installation & Operation Manual" for Hurricane® Swing Bolt Filters.

Note: This publication is to be used as a guide. The data within has been obtained from many sources and is considered to be accurate. Harmsco does not assume liability for the accuracy and/or completeness of this data. Changes to the data can be made without notification. Temperature, Pressure, Flow Rates, Differential Pressures, Chemical Combinations and other unknown factors can affect performance in unknown ways. **Limited Warranty:** Harmsco warrants their products to be free of material and workmanship defects. Determination of suitability of Harmsco products for uses and applications contemplated by Buyer shall be the sole responsibility of Buyer. The end user/installer/buyer shall be liable for the product's performance and suitability regarding their specific intended applications. End users should perform their own tests to determine suitability for each application.



HARMSCO® Filtration Products

P.O. Box 14066, North Palm Beach, FL 33408

(561) 848-9628 • Toll-free: (800) 327-3248 • Fax: (561) 845-2474 • E-mail: sales@harmsco.com

www.harmsco.com



Hurricane® Filter Housings

Two Technologies in One

Lower Operation Cost

- Harmsco® HP Hurricane® filters provide unsurpassed performance. Our unique design separates dense solids prior to cartridge filtration for extended filter life, increased dirt holding capacity and reduced maintenance costs.



Certified to
ANSI-NSF 61

Features

- ▶ Combination cyclone separator and cartridge filter in a single compact design
- ▶ Patented Up-flow design with tangential entry - prevents air entrapment
- ▶ Rotational flow “flutters” media pleats - improving loading performance
- ▶ Electropolished 304 stainless steel housing
- ▶ Fail-Safe lid closure, rated for 150 psi
- ▶ Three sizes for greater media surface area
- ▶ CPVC standpipe (standard) - stainless steel optional
- ▶ Extensive choice of cartridge micron ratings and media, including carbon block
- ▶ NSF 61 listed



Applications

- ▶ Commercial/Residential Drinking Water
- ▶ Cooling Tower Filtration
- ▶ Desalination Pre-filtration (316 and coated options)
- ▶ Surface Water Treatment Rule (SWTR) LT2
- ▶ Process Water
- ▶ Whole House Filtration
- ▶ Industrial Waste Water Treatment
- ▶ Reverse Osmosis Pre-filtration
- ▶ Small Community Compliance LT2
- ▶ Well Water
- ▶ Ground Water Remediation
- ▶ Ground Water Under Direct Influence (GUDI)



Cartridge Selection

Sediment Removal, Turbidity Reduction, Chlorine Removal, Taste & Odor Reduction, Cyst Removal, Pre-Filtration, Post-Filtration, Antimicrobial, Absolute Rated, Nominal Rated, 100% Synthetic, Non Potable Use Only, Course Filtration, High Temperature, All Polypropylene, NSF Listed, Cleanable/ Reusable

Polyester-Plus™ - engineered for high efficiency, low pressure drops; NSF 61 Listed

Part Number	Description	Sediment Removal	Turbidity Reduction	Chlorine Removal	Taste & Odor Reduction	Cyst Removal	Pre-Filtration	Post-Filtration	Antimicrobial	Absolute Rated	Nominal Rated	100% Synthetic	Non Potable Use Only	Course Filtration	High Temperature	All Polypropylene	NSF Listed	Cleanable/ Reusable
HC/40-0.35	Hur 40 Cartridge - 0.35 Micron	•	•				•			•						•		
HC/40-1	Hur 40 Cartridge - 1 Micron	•	•				•			•						•		
HC/40-5	Hur 40 Cartridge - 5 Micron	•	•				•	•		•						•	•	
HC/40-10	Hur 40 Cartridge - 10 Micron	•	•				•	•		•						•	•	
HC/40-20	Hur 40 Cartridge - 20 Micron	•	•				•	•		•			•			•	•	
HC/40-50	Hur 40 Cartridge - 50 Micron	•	•				•	•		•			•			•	•	
HC/40-100	Hur 40 Cartridge - 100 Micron	•	•				•	•		•			•			•	•	
HC/40-150	Hur 40 Cartridge - 150 Micron	•	•				•	•		•			•			•	•	
HC/90-0.35	Hur 90 Cartridge - 0.35 Micron	•	•				•	•		•						•		
HC/90-1	Hur 90 Cartridge - 1 Micron	•	•				•	•		•						•		
HC/90-5	Hur 90 Cartridge - 5 Micron	•	•				•	•		•						•	•	
HC/90-10	Hur 90 Cartridge - 10 Micron	•	•				•	•		•						•	•	
HC/90-20	Hur 90 Cartridge - 20 Micron	•	•				•	•		•			•			•	•	
HC/90-50	Hur 90 Cartridge - 50 Micron	•	•				•	•		•			•			•	•	
HC/90-100	Hur 90 Cartridge - 100 Micron	•	•				•	•		•			•			•	•	
HC/90-150	Hur 90 Cartridge - 150 Micron	•	•				•	•		•			•			•	•	
HC/170-0.35	Hur 170 Cartridge - 0.35 Micron	•	•				•	•		•						•		
HC/170-1	Hur 170 Cartridge - 1 Micron	•	•				•	•		•						•		
HC/170-5	Hur 170 Cartridge - 5 Micron	•	•				•	•		•						•	•	
HC/170-10	Hur 170 Cartridge - 10 Micron	•	•				•	•		•						•	•	
HC/170-20	Hur 170 Cartridge - 20 Micron	•	•				•	•		•			•			•	•	
HC/170-50	Hur 170 Cartridge - 50 Micron	•	•				•	•		•			•			•	•	
HC/170-100	Hur 170 Cartridge - 100 Micron	•	•				•	•		•			•			•	•	
HC/170-150	Hur 170 Cartridge - 150 Micron	•	•				•	•		•			•			•	•	

High Temperature - up to 200°F (93°C)* *250°F (121°C) with metal end caps, using suffix "HTM"

Part Number	Description	Sediment Removal	Turbidity Reduction	Chlorine Removal	Taste & Odor Reduction	Cyst Removal	Pre-Filtration	Post-Filtration	Antimicrobial	Absolute Rated	Nominal Rated	100% Synthetic	Non Potable Use Only	Course Filtration	High Temperature	All Polypropylene	NSF Listed	Cleanable/ Reusable
HC/40-20HT	Hur 40 Cartridge - 20 Micron High Temp	•	•				•			•				•	•			•
HC/40-50HT	Hur 40 Cartridge - 50 Micron High Temp	•	•				•			•				•	•			•
HC/90-5CPHT	Hur 90 Cartridge - 5 Micron High Temp	•	•				•	•		•		•		•	•			•
HC/90-5HT	Hur 90 Cartridge - 5 Micron High Temp	•	•				•	•		•				•	•			•
HC/90-10HT	Hur 90 Cartridge - 10 Micron High Temp	•	•				•	•		•				•	•			•
HC/90-20HT	Hur 90 Cartridge - 20 Micron High Temp	•	•				•	•		•				•	•			•
HC/90-50HT	Hur 90 Cartridge - 50 Micron High Temp	•	•				•	•		•				•	•			•
HC/170-5CPHT	Hur 170 Cartridge - 5 Micron High Temp	•	•				•	•		•		•		•	•			•
HC/170-5HT	Hur 170 Cartridge - 5 Micron High Temp	•	•				•	•		•				•	•			•
HC/170-10HT	Hur 170 Cartridge - 10 Micron High Temp	•	•				•	•		•				•	•			•
HC/170-20HT	Hur 170 Cartridge - 20 Micron High Temp	•	•				•	•		•				•	•			•
HC/170-50HT	Hur 170 Cartridge - 50 Micron High Temp	•	•				•	•		•				•	•			•

Harmsco-Free - 100% synthetic composite media; NSF 61 Listed

Part Number	Description	Sediment Removal	Turbidity Reduction	Chlorine Removal	Taste & Odor Reduction	Cyst Removal	Pre-Filtration	Post-Filtration	Antimicrobial	Absolute Rated	Nominal Rated	100% Synthetic	Non Potable Use Only	Course Filtration	High Temperature	All Polypropylene	NSF Listed	Cleanable/ Reusable
HC/40-1W-HF	Hur 40 Cartridge - 1 Micron	•	•				•			•	•						•	
HC/40-5W-HF	Hur 40 Cartridge - 5 Micron	•	•				•			•	•						•	•
HC/40-20W-HF	Hur 40 Cartridge - 20 Micron	•	•				•			•	•		•				•	•
HC/90-1W-HF	Hur 90 Cartridge - 1 Micron	•	•				•			•	•						•	
HC/90-5W-HF	Hur 90 Cartridge - 5 Micron	•	•				•			•	•						•	•
HC/90-20W-HF	Hur 90 Cartridge - 20 Micron	•	•				•			•	•		•				•	•
HC/170-1W-HF	Hur 170 Cartridge - 1 Micron	•	•				•			•	•						•	
HC/170-5W-HF	Hur 170 Cartridge - 5 Micron	•	•				•			•	•						•	•
HC/170-20W-HF	Hur 170 Cartridge - 20 Micron	•	•				•			•	•		•				•	•

Poly-Pleat™ - 1 micron absolute, multi-layered media; NSF 61 Listed

Part Number	Description	Sediment Removal	Turbidity Reduction	Chlorine Removal	Taste & Odor Reduction	Cyst Removal	Pre-Filtration	Post-Filtration	Antimicrobial	Absolute Rated	Nominal Rated	100% Synthetic	Non Potable Use Only	Course Filtration	High Temperature	All Polypropylene	NSF Listed	Cleanable/ Reusable
PP-HC-40-1	Poly Pleat Hur 40 Cartridge - 1 Micron	•	•			•	•			•	•						•	
PPFS-HC-40-1	PP-Fail Safe Hur 40 Cartridge - 1 Micron	•	•			•	•			•	•						•	
PP-HC-90-1	Poly Pleat Hur 90 Cartridge - 1 Micron	•	•			•	•			•	•						•	
PPFS-HC-90-1	PP-Fail Safe Hur 90 Cartridge - 1 Micron	•	•			•	•			•	•						•	
PP-HC-170-1	Poly Pleat Hur 170 Cartridge - 1 Micron	•	•			•	•			•	•						•	
PPFS-HC-170-1	PP-Fail Safe Hur 170 Cartridge - 1 Micron	•	•			•	•			•	•						•	

All-Poly - 100% polypropylene media with polypropylene end caps and components; also available in 10, 20 and 50 micron ratings

Part Number	Description	Sediment Removal	Turbidity Reduction	Chlorine Removal	Taste & Odor Reduction	Cyst Removal	Pre-Filtration	Post-Filtration	Antimicrobial	Absolute Rated	Nominal Rated	100% Synthetic	Non Potable Use Only	Course Filtration	High Temperature	All Polypropylene	NSF Listed	Cleanable/ Reusable
HC-PP-40-0.2	Hur 40 High Purity Pleated PP - 0.2 Mic	•	•			•	•			•						•		
HC-PP-40-0.45	Hur 40 High Purity Pleated PP - 0.45 Mic	•	•			•	•			•						•		
HC-PP-40-1	Hur 40 High Purity Pleated PP - 1 Mic	•	•			•	•			•						•		
HC-PP-40-5	Hur 40 High Purity Pleated PP - 5 Mic	•	•			•	•			•						•		
HC-PP-90-0.2	Hur 90 High Purity Pleated PP - 0.2 Mic	•	•			•	•			•						•		
HC-PP-90-0.45	Hur 90 High Purity Pleated PP - 0.45 Mic	•	•			•	•			•						•		
HC-PP-90-1	Hur 90 High Purity Pleated PP - 1 Mic	•	•			•	•			•						•		
HC-PP-90-5	Hur 90 High Purity Pleated PP - 5 Mic	•	•			•	•			•						•		
HC-PP-170-0.2	Hur 170 High Purity Pleated PP - 0.2 Mic	•	•			•	•			•						•		
HC-PP-170-0.45	Hur 170 High Purity Pleated PP - 0.45 Mic	•	•			•	•			•						•		
HC-PP-170-1	Hur 170 High Purity Pleated PP - 1 Mic	•	•			•	•			•						•		
HC-PP-170-5	Hur 170 High Purity Pleated PP - 5 Mic	•	•			•	•			•						•		

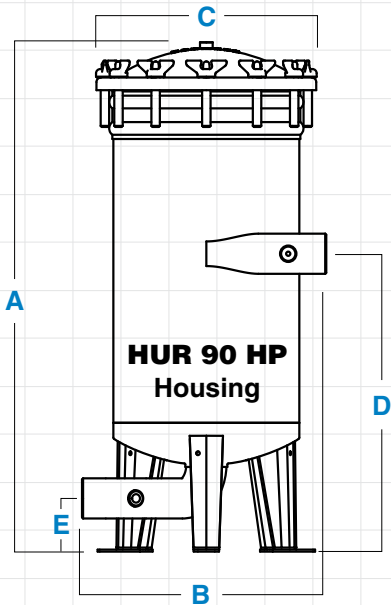

HUR 40 HP



HUR 90 HP



HUR 170 HP

Ordering Information

Filter Model	A Filter Height	B Width	C Diameter	D Inlet	E Outlet	Pipe Size NPT	Drain Size NPT	Floor Space	Service Ht.	Shipping Wt. Lbs.	Carton Size In.
HUR 40 HP	19-1/2"	14-3/8"	13"	12-3/4"	3-7/16"	2"	1"	15"x15"	35"	40	14x16x21
HUR 90 HP	29-7/8"	14-3/8"	13"	17-3/4"	3-7/16"	2"	1"	15"x15"	51"	52	14x16x38
HUR 170 HP	40-1/2"	14-3/8"	13"	23-5/8"	3-7/16"	2"	1"	15"x15"	72"	64	14x16x42

Filter Specifications

- ▶ Electropolished 304 stainless steel
- ▶ Standpipe - CPVC
- ▶ Temperature - 140°F (60°C) max. Up to 250°F (121°C) with optional stainless steel standpipe and high temperature cartridges installed
- ▶ Wing nuts - brass
- ▶ Rim gaskets - EPDM (Buna-N, Viton available)
- ▶ BSTP optional
- ▶ Gauge sample ports (1/4"), inlet and outlet
- ▶ Pressure - 150 psi (10 bar) max.

All stainless steel housings are 304; 316 available upon request. Stainless steel standpipe for high temperature also available.

Pressure Drop

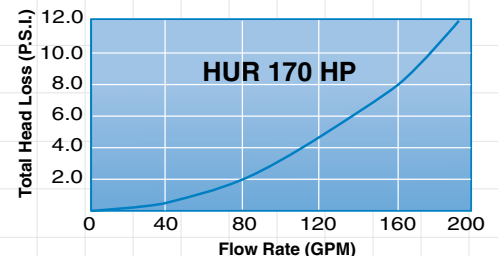
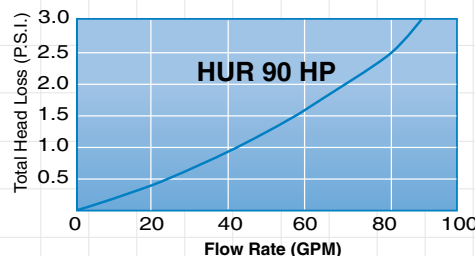
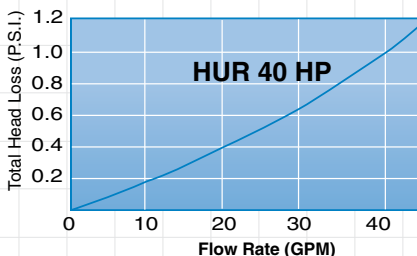

The total head loss data shown above was developed by NSF International and indicates pressure drop with Hurricane® filter housings and 20 micron filter cartridges in clean water.

For additional information, please refer to the "Installation & Operation Manual" for Hurricane® Filters.

Note: This publication is to be used as a guide. The data within has been obtained from many sources and is considered to be accurate. Harmsco does not assume liability for the accuracy and/or completeness of this data. Changes to the data can be made without notification. Temperature, Pressure, Flow Rates, Differential Pressures, Chemical Combinations and other unknown factors can affect performance in unknown ways. **Limited Warranty:** Harmsco warrants their products to be free of material and workmanship defects. Determination of suitability of Harmsco products for uses and applications contemplated by Buyer shall be the sole responsibility of Buyer. The end user/installer/buyer shall be liable for the product's performance and suitability regarding their specific intended applications. End users should perform their own tests to determine suitability for each application.



HARMSCO® Filtration Products

P.O. Box 14066, North Palm Beach, FL 33408

(561) 848-9628 • Toll-free: (800) 327-3248 • Fax: (561) 845-2474 • E-mail: sales@harmsco.com

www.harmsco.com



Made in USA

© Harmsco, Inc. 07D 45 7/11

Filter Housings – Tab 2

WB and WB 5x170FL WaterBetter® Housings

WB WaterBetter® Housings

- ▶ Single cartridge design
- ▶ Patented Up-flow design
- ▶ Offered in 304 and 316 stainless steel
- ▶ Coated option available
- ▶ Flow rates up to 150 GPM



WB 5x170FL WaterBetter® Housings

- ▶ Patented Up-flow design
- ▶ Electropolished
- ▶ Flow rates up to 600 GPM



Sizing Info:

WaterBetter® housings accept 7-3/4" O.D. Hurricane® cartridges.

Cartridge Options

Hurricane® Cartridges (Tab 21)

- ▶ High flow, high surface area
- ▶ Low initial pressure drop provides longer filter life
- ▶ NSF-61 Listed cartridges available
- ▶ High Temperature cartridges available
- ▶ Lowest cost per filtered gallon based on surface area

SureSafe™ Cartridges (Tab 25)

- ▶ Antimicrobial cartridge media prohibits growth of bacteria and mold on filter cartridge
- ▶ Offered in 20 and 50 micron ratings and a wide range of cartridge sizes
- ▶ Agion Silver Zeolite is FDA tested and registered with the EPA

Premium Poly-Pleat™ Cartridges (Tab 26)

- ▶ Pleated one micron absolute cartridges for safe, cyst-free drinking water
- ▶ NSF-61 Listed
- ▶ Available in a wide range of cartridge sizes

Carbon Cartridges (Tab 27)

- ▶ For high chlorine, taste, odor, lead, THM and organic chemical removal
- ▶ Available in a wide range of cartridge sizes, including Hurricane® 170 Series
- ▶ NSF-42 Listed

All-Poly/High Purity Cartridges (Tab 28)

- ▶ Available in Hurricane® sizes 40, 90 and 170, and in micron ratings 0.2, 0.45, 1, 5, 10, 20 and 50

High-Temp Cartridges (Tab 29)

- ▶ Pleated design; high flow capacity
- ▶ Two temperature ratings (200°F/93°C and 250°F/121°C)
- ▶ Not available for WB 5x170FL WaterBetter® housing

Note: This publication is to be used as a guide. The data within has been obtained from many sources and is considered to be accurate. Harmsco does not assume liability for the accuracy and/or completeness of this data. Changes to the data can be made without notification. Temperature, Pressure, Flow Rates, Differential Pressures, Chemical Combinations and other unknown factors can affect performance in unknown ways. **Limited Warranty:** Harmsco warrants their products to be free of material and workmanship defects. Determination of suitability of Harmsco products for uses and applications contemplated by Buyer shall be the sole responsibility of Buyer. The end user/installer/buyer shall be liable for the product's performance and suitability regarding their specific intended applications. End users should perform their own tests to determine suitability for each application.

WaterBetter® Filter Housings

Single Cartridge Design

Lower Operation Cost

- Harmsco® WB WaterBetter® single-cartridge filters deliver high flow, extended filter life, increased dirt holding capacity and ease of operation.



Certified to
ANSI-NSF 61

Features

- ▶ Patented Up-flow design
- ▶ Electropolished 304 stainless steel housing
- ▶ Fail Safe closure system
- ▶ Three sizes for greater media surface area
- ▶ CPVC standpipe (standard) - stainless steel optional
- ▶ Simple alternative to complex multiple cartridge housings
- ▶ Extensive choice of cartridge micron ratings and media, including carbon block
- ▶ Reduced installation cost



Applications

- ▶ Commercial/Residential Drinking Water
- ▶ Cooling Tower Filtration
- ▶ Desalination Pre-filtration (coated option)
- ▶ Surface Water Treatment Rule (SWTR) LT2
- ▶ P.O.E. for household
- ▶ Industrial Waste Water Treatment
- ▶ Reverse Osmosis Pre-filtration
- ▶ Ground Water Remediation
- ▶ Utility Water
- ▶ Ground Water Under Direct Influence (GUDI)



Cartridge Selection

Sediment Removal
 Turbidity Reduction
 Chlorine Removal
 Taste & Odor Reduction
 Cyst Removal
 Pre-Filtration
 Post-Filtration
 Antimicrobial
 Absolute Rated
 Nominal Rated
 100% Synthetic
 Non Potable Use Only
 Course Filtration
 High Temperature
 All Polypropylene
 NSF Listed
 Cleanable/ Reusable

Polyester-Plus™ - engineered for high efficiency, low pressure drops; **NSF 61 Listed**

Model	Description	Sediment Removal	Turbidity Reduction	Chlorine Removal	Taste & Odor Reduction	Cyst Removal	Pre-Filtration	Post-Filtration	Antimicrobial	Absolute Rated	Nominal Rated	100% Synthetic	Non Potable Use Only	Course Filtration	High Temperature	All Polypropylene	NSF Listed	Cleanable/ Reusable
HC/40-0.35	Hur 40 Cartridge - 0.35 Micron	•	•				•			•							•	
HC/40-1	Hur 40 Cartridge - 1 Micron	•	•				•			•							•	
HC/40-5	Hur 40 Cartridge - 5 Micron	•	•				•	•		•							•	•
HC/40-10	Hur 40 Cartridge - 10 Micron	•	•				•	•		•							•	•
HC/40-20	Hur 40 Cartridge - 20 Micron	•	•				•	•		•			•				•	•
HC/40-50	Hur 40 Cartridge - 50 Micron	•	•				•	•		•			•				•	•
HC/40-100	Hur 40 Cartridge - 100 Micron	•	•				•	•		•			•				•	•
HC/40-150	Hur 40 Cartridge - 150 Micron	•	•				•	•		•			•				•	•
HC/90-0.35	Hur 90 Cartridge - 0.35 Micron	•	•				•	•		•							•	
HC/90-1	Hur 90 Cartridge - 1 Micron	•	•				•	•		•							•	
HC/90-5	Hur 90 Cartridge - 5 Micron	•	•				•	•		•							•	•
HC/90-10	Hur 90 Cartridge - 10 Micron	•	•				•	•		•							•	•
HC/90-20	Hur 90 Cartridge - 20 Micron	•	•				•	•		•			•				•	•
HC/90-50	Hur 90 Cartridge - 50 Micron	•	•				•	•		•			•				•	•
HC/90-100	Hur 90 Cartridge - 100 Micron	•	•				•	•		•			•				•	•
HC/90-150	Hur 90 Cartridge - 150 Micron	•	•				•	•		•			•				•	•
HC/170-0.35	Hur 170 Cartridge - 0.35 Micron	•	•				•	•		•							•	
HC/170-1	Hur 170 Cartridge - 1 Micron	•	•				•	•		•							•	
HC/170-5	Hur 170 Cartridge - 5 Micron	•	•				•	•		•							•	•
HC/170-10	Hur 170 Cartridge - 10 Micron	•	•				•	•		•							•	•
HC/170-20	Hur 170 Cartridge - 20 Micron	•	•				•	•		•			•				•	•
HC/170-50	Hur 170 Cartridge - 50 Micron	•	•				•	•		•			•				•	•
HC/170-100	Hur 170 Cartridge - 100 Micron	•	•				•	•		•			•				•	•
HC/170-150	Hur 170 Cartridge - 150 Micron	•	•				•	•		•			•				•	•

High Temperature - up to 200°F (93°C)* *250°F (121°C) with metal end caps, using suffix "HTM"

Model	Description	Sediment Removal	Turbidity Reduction	Chlorine Removal	Taste & Odor Reduction	Cyst Removal	Pre-Filtration	Post-Filtration	Antimicrobial	Absolute Rated	Nominal Rated	100% Synthetic	Non Potable Use Only	Course Filtration	High Temperature	All Polypropylene	NSF Listed	Cleanable/ Reusable
HC/40-20HT	Hur 40 Cartridge - 20 Micron High Temp	•	•				•			•				•	•			•
HC/40-50HT	Hur 40 Cartridge - 50 Micron High Temp	•	•				•			•				•	•			•
HC/90-5CPHT	Hur 90 Cartridge - 5 Micron High Temp	•	•				•	•		•			•		•			•
HC/90-5HT	Hur 90 Cartridge - 5 Micron High Temp	•	•				•	•		•			•		•			•
HC/90-10HT	Hur 90 Cartridge - 10 Micron High Temp	•	•				•	•		•			•		•			•
HC/90-20HT	Hur 90 Cartridge - 20 Micron High Temp	•	•				•	•		•			•		•			•
HC/90-50HT	Hur 90 Cartridge - 50 Micron High Temp	•	•				•	•		•			•		•			•
HC/170-5CPHT	Hur 170 Cartridge - 5 Micron High Temp	•	•				•	•		•			•		•			•
HC/170-5HT	Hur 170 Cartridge - 5 Micron High Temp	•	•				•	•		•			•		•			•
HC/170-10HT	Hur 170 Cartridge - 10 Micron High Temp	•	•				•	•		•			•		•			•
HC/170-20HT	Hur 170 Cartridge - 20 Micron High Temp	•	•				•	•		•			•		•			•
HC/170-50HT	Hur 170 Cartridge - 50 Micron High Temp	•	•				•	•		•			•		•			•

Harmsco-Free - 100% synthetic composite media; **NSF 61 Listed**

Model	Description	Sediment Removal	Turbidity Reduction	Chlorine Removal	Taste & Odor Reduction	Cyst Removal	Pre-Filtration	Post-Filtration	Antimicrobial	Absolute Rated	Nominal Rated	100% Synthetic	Non Potable Use Only	Course Filtration	High Temperature	All Polypropylene	NSF Listed	Cleanable/ Reusable
HC/40-1W-HF	Hur 40 Cartridge - 1 Micron	•	•				•			•	•						•	
HC/40-5W-HF	Hur 40 Cartridge - 5 Micron	•	•				•			•	•						•	•
HC/40-20W-HF	Hur 40 Cartridge - 20 Micron	•	•				•			•	•		•				•	•
HC/90-1W-HF	Hur 90 Cartridge - 1 Micron	•	•				•			•	•						•	
HC/90-5W-HF	Hur 90 Cartridge - 5 Micron	•	•				•			•	•						•	•
HC/90-20W-HF	Hur 90 Cartridge - 20 Micron	•	•				•			•	•		•				•	•
HC/170-1W-HF	Hur 170 Cartridge - 1 Micron	•	•				•			•	•						•	•
HC/170-5W-HF	Hur 170 Cartridge - 5 Micron	•	•				•			•	•						•	•
HC/170-20W-HF	Hur 170 Cartridge - 20 Micron	•	•				•			•	•		•				•	•

Poly-Pleat™ - 1 micron absolute, multi-layered media; **NSF 61 Listed**

Model	Description	Sediment Removal	Turbidity Reduction	Chlorine Removal	Taste & Odor Reduction	Cyst Removal	Pre-Filtration	Post-Filtration	Antimicrobial	Absolute Rated	Nominal Rated	100% Synthetic	Non Potable Use Only	Course Filtration	High Temperature	All Polypropylene	NSF Listed	Cleanable/ Reusable
PP-HC-40-1	Poly Pleat Hur 40 Cartridge - 1 Micron	•	•			•	•			•	•						•	
PPFS-HC-40-1	PP-Fail Safe Hur 40 Cartridge - 1 Micron	•	•			•	•			•	•						•	
PP-HC-90-1	Poly Pleat Hur 90 Cartridge - 1 Micron	•	•			•	•			•	•						•	
PPFS-HC-90-1	PP-Fail Safe Hur 90 Cartridge - 1 Micron	•	•			•	•			•	•						•	
PP-HC-170-1	Poly Pleat Hur 170 Cartridge - 1 Micron	•	•			•	•			•	•						•	
PPFS-HC-170-1	PP-Fail Safe Hur 170 Cartridge - 1 Micron	•	•			•	•			•	•						•	

All-Poly - 100% polypropylene media with polypropylene end caps and components; also available in 10, 20 and 50 micron ratings

Model	Description	Sediment Removal	Turbidity Reduction	Chlorine Removal	Taste & Odor Reduction	Cyst Removal	Pre-Filtration	Post-Filtration	Antimicrobial	Absolute Rated	Nominal Rated	100% Synthetic	Non Potable Use Only	Course Filtration	High Temperature	All Polypropylene	NSF Listed	Cleanable/ Reusable
HC-PP-40-0.2	Hur 40 High Purity Pleated PP - 0.2 Mic	•	•			•	•			•							•	
HC-PP-40-0.45	Hur 40 High Purity Pleated PP - 0.45 Mic	•	•			•	•			•							•	
HC-PP-40-1	Hur 40 High Purity Pleated PP - 1 Mic	•	•			•	•			•							•	
HC-PP-40-5	Hur 40 High Purity Pleated PP - 5 Mic	•	•			•	•			•							•	
HC-PP-90-0.2	Hur 90 High Purity Pleated PP - 0.2 Mic	•	•			•	•			•							•	
HC-PP-90-0.45	Hur 90 High Purity Pleated PP - 0.45 Mic	•	•			•	•			•							•	
HC-PP-90-1	Hur 90 High Purity Pleated PP - 1 Mic	•	•			•	•			•							•	
HC-PP-90-5	Hur 90 High Purity Pleated PP - 5 Mic	•	•			•	•			•							•	
HC-PP-170-0.2	Hur 170 High Purity Pleated PP - 0.2 Mic	•	•			•	•			•							•	
HC-PP-170-0.45	Hur 170 High Purity Pleated PP - 0.45 Mic	•	•			•	•			•							•	
HC-PP-170-1	Hur 170 High Purity Pleated PP - 1 Mic	•	•			•	•			•							•	
HC-PP-170-5	Hur 170 High Purity Pleated PP - 5 Mic	•	•			•	•			•							•	

40

90

170

Sediment Removal
 Turbidity Reduction
 Chlorine Removal
 Taste & Odor Reduction
 Cyst Removal
 Pre-Filtration
 Post-Filtration
 Antimicrobial Absolute Rated
 Nominal Rated
 100% Synthetic
 Non Potable Use Only
 Course Filtration
 High Temperature
 All Polypropylene
 NSF Listed
 Cleanable/ Reusable

SureSafe™ Antimicrobial - reduces growth of bacteria and mold on media

HC/40-20-AM	Hur 40 Cartridge - 20 Micron	●	●			●			●	●		●		●
HC/40-50-AM	Hur 40 Cartridge - 50 Micron	●	●			●			●	●		●		●
HC/90-20-AM	Hur 90 Cartridge - 20 Micron	●	●			●			●	●		●		●
HC/90-50-AM	Hur 90 Cartridge - 50 Micron	●	●			●			●	●		●		●
HC/170-20-AM	Hur 170 Cartridge - 20 Micron	●	●			●			●	●		●		●
HC/170-50-AM	Hur 170 Cartridge - 50 Micron	●	●			●			●	●		●		●

Carbon Block - includes pleated 5 micron nominal pre-filtration

HC/40-AC-5	Hur 40 Cart. Carbon + 5 Mic Pre-filt	●	●	●	●				●					●
HC/90-AC-5	Hur 90 Cart. Carbon + 5 Mic Pre-filt	●	●	●	●				●					●
HC/170-AC-5	Hur 170 Cart. Carbon + 5 Mic Pre-filt	●	●	●	●				●					●

EZ Clean - 100% synthetic composite 50 micron media

HC/40-EZ-CLEAN	Hur Cartridge - EZ CLEAN - 50 Micron	●	●						●	●				●
HC/90-EZ-CLEAN	Hur Cartridge - EZ CLEAN - 50 Micron	●	●						●	●				●
HC/170-EZ-CLEAN	Hur Cartridge - EZ CLEAN - 50 Micron	●	●						●	●				●

Poly-Mesh - 100% synthetic composite 250 micron media

HC/170-PM	Hur 170 Cartridge Poly Mesh - 250 Micron	●	●						●	●			●	●
-----------	--	---	---	--	--	--	--	--	---	---	--	--	---	---

Note: WaterBetter® Single Cartridge Filters Use Hurricane® Cartridges

Cartridge Sizing Guide

Cleanable/ Reusable Hurricane® cartridges are cleanable and reusable in most applications and micron ratings (5 micron and up).

For Harmsco® Hurricane® and WaterBetter® Single-cartridge Filter Houings

Harmsco® recommends operation at 70% of maximum flow rate for optimum performance.

Polyester-Plus™, High Temp, Harmsco-Free, SureSafe™, EZ Clean, Poly-Mesh

Filter Model	Pleated Media Area (sq.ft.)	Length (in.)	O.D. (in.)	Max Flow Rate (GPM)	Recommended Flow Rate (GPM)	Max Flow Rate (LPM)	Max Flow Rate (M ³ /HR)	No./ Case	Carton Size
WB 40SC-2*	40	9-5/8	7-3/4	Up to 50	35	Up to 189	Up to 12	1	9x9x11
WB 90SC-2*	90	19-1/2	7-3/4	Up to 100	70	Up to 378	Up to 24	1	9x9x21
WB 170SC-2*	170	30-3/4	7-3/4	Up to 150	105	Up to 568	Up to 36	1	9x9x32

Poly-Pleat™

WB 40SC-2*	25	9-5/8	7-3/4	-	15	-	-	1	9x9x11
WB 90SC-2*	50	19-1/2	7-3/4	-	25	-	-	1	9x9x21
WB 170SC-2*	100	30-3/4	7-3/4	-	50	-	-	1	9x9x32

All-Poly

WB 40SC-2*	25	9-5/8	7-3/4	25	17	19	Up to 12	1	9x9x11
WB 90SC-2*	50	19-1/2	7-3/4	50	35	38	Up to 24	1	9x9x21
WB 170SC-2*	75	30-3/4	7-3/4	100	60 ^a	76	Up to 36	1	9x9x32

Carbon Block

WB 40SC-2*	25	9-5/8	7-3/4	-	5 ^b	-	-	1	9x9x11
WB 90SC-2*	55	19-1/2	7-3/4	-	10 ^b	-	-	1	9x9x21
WB 170SC-2*	90	30-3/4	7-3/4	-	15 ^b	-	-	1	9x9x32

^a based on 1, 5, 10, 20 and 50 micron ratings

*"2" represents 2 inch inlet/outlet pipe size; use "1" for 1 inch (not NSF Listed)



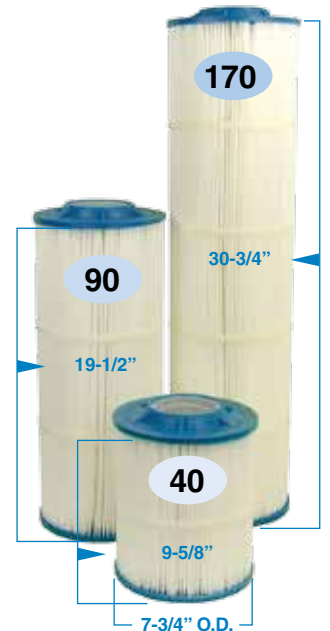





^b recommended flow for maximum chlorine removal

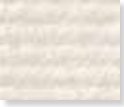

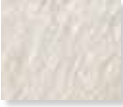
Hurricane® Cartridges
Length and O.D.

Cartridge Sizing Guide

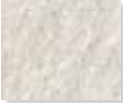
Media Options

Polyester-Plus™  NSF 61 Listed	High Temperature 	Harmsco-Free  NSF 61 Listed	Poly-Pleat™ (multi-layer)  NSF 61 Listed	All-Poly (multi-layer) 
SureSafe™ (antimicrobial) 	Carbon Block (5 Micron Pleated Pre-filter) 	EZ Clean 	Poly-Mesh 	

cartridges in the industry for all your filtration needs.

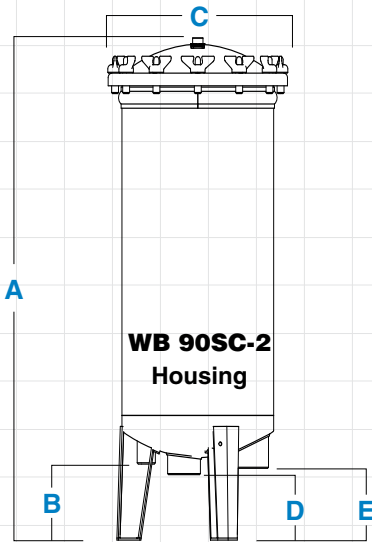

WB 40SC-2



WB 90SC-2



WB 170SC-2

Ordering Information

Filter Model	A Filter Height	B Drain	C Diameter	D Outlet	E Inlet	Pipe Size NPT	Drain Size NPT	Floor Space	Service Ht.	Shipping Wt. Lbs.	Carton Size In.
WB 40SC-1*	19-1/4"	4-1/2"	13"	3-7/8"	4-1/4"	1"	1"	15"x15"	31"	40	14x16x21
WB 40SC-2	19-1/4"	4-1/2"	13"	3-7/8"	4-1/4"	2"	1"	15"x15"	31"	40	14x16x21
WB 90SC-1*	29-3/8"	4-1/2"	13"	3-7/8"	4-1/4"	1"	1"	15"x15"	51"	51	14x16x38
WB 90SC-2	29-3/8"	4-1/2"	13"	3-7/8"	4-1/4"	2"	1"	15"x15"	51"	51	14x16x38
WB 170SC-1*	39-1/8"	4-1/2"	13"	3-7/8"	4-1/4"	1"	1"	15"x15"	72"	64	14x16x42
WB 170SC-2	39-1/8"	4-1/2"	13"	3-7/8"	4-1/4"	2"	1"	15"x15"	72"	64	14x16x42

*For 1" plumbing; not NSF Listed.

Filter Specifications

- ▶ Electropolished 304 stainless steel
- ▶ Standpipe - CPVC
- ▶ Temperature - 140°F (60°C) max. Up to 200°F (93°C) with optional stainless steel standpipe and high temperature cartridges installed
- ▶ Pressure - 150 psi (10 bar) max.
- ▶ Wing nuts - brass
- ▶ Rim gaskets - EPDM (Buna-N, Viton available)
- ▶ BSTP optional

All stainless steel housings are 304; 316 available upon request. Stainless steel standpipe for high temperature also available.

Pressure Drop

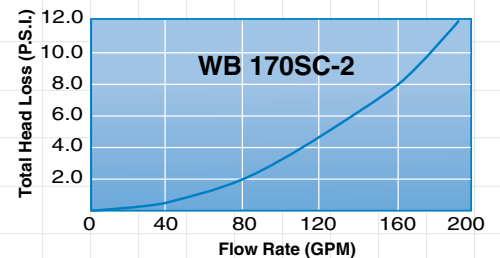
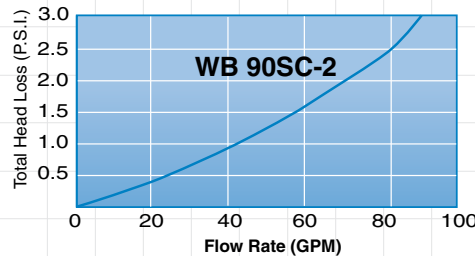
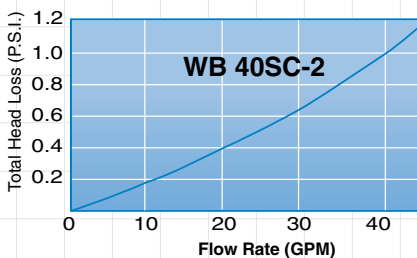

The total head loss data shown above was developed by NSF International and indicates pressure drop with WaterBetter® filter housings and 20 micron filter cartridges in clean water.

For additional information, please refer to the "Installation & Operation Manual" for WaterBetter® Filters.

Note: This publication is to be used as a guide. The data within has been obtained from many sources and is considered to be accurate. Harmsco does not assume liability for the accuracy and/or completeness of this data. Changes to the data can be made without notification. Temperature, Pressure, Flow Rates, Differential Pressures, Chemical Combinations and other unknown factors can affect performance in unknown ways. **Limited Warranty:** Harmsco warrants their products to be free of material and workmanship defects. Determination of suitability of Harmsco products for uses and applications contemplated by Buyer shall be the sole responsibility of Buyer. The end user/installer/buyer shall be liable for the product's performance and suitability regarding their specific intended applications. End users should perform their own tests to determine suitability for each application.



HARMSCO® Filtration Products

P.O. Box 14066, North Palm Beach, FL 33408

(561) 848-9628 • Toll-free: (800) 327-3248 • Fax: (561) 845-2474 • E-mail: sales@harmsco.com

www.harmsco.com



Made in USA

© Harmsco, Inc. 05C 33 7/11

HARMSCO®

WB5x

5x170FL WaterBetter® Filter Housing

High Capacity Design

Lower Operation Cost

- High flow capability
- Lower overall operating cost
- Reduced waste disposal
- Longer filter runs for fewer change-outs
- Increased contaminant removal
- Operator friendly

Features

- ▶ Patented up-flow design
- ▶ Convenient 5 jumbo-cartridge cluster design
- ▶ Fail safe lids with individual studs
- ▶ Rated for pressures to 125 PSI
- ▶ Rated for temperatures to 140°F (60°C)
- ▶ Electropolished 304 stainless steel housing with CPVC standpipes
- ▶ Minimal pressure drop with Harmsco® cartridges due to pleated design and increased filter area



WB 5x170FL

Applications

- ▶ Commercial/Residential Drinking Water
- ▶ Cooling Tower Filtration
- ▶ Desalination Pre-filtration (coated option)
- ▶ Surface Water Treatment Rule (SWTR) LT2
- ▶ Industrial Waste Water Treatment
- ▶ Reverse Osmosis Pre-filtration
- ▶ Ground Water Remediation
- ▶ Utility Water
- ▶ Ground Water Under Direct Influence (GUDI)



HARMSCO® Filtration Products



Made in USA

Cartridge Sizing Guide

Cartridges available in the following media:

Polyester-Plus™, Harmsco-Free, SureSafe™, EZ Clean, Poly-Mesh

Filter Model	NO. of Cartridges	Pleated Media Area (sq.ft.)	Length (in.)	O.D. (in.)	Recommended Flow Rate* (GPM)	Max Flow Rate (GPM)	Max Flow Rate (LPM)	Max Flow Rate (M ³ /HR)
WB 5x170FL	5	850	30-3/4	7-3/4	525	750	2,839	170

Poly-Pleat™

WB 5x170FL	5	500	30-3/4	7-3/4	250*	-	-	-
------------	---	-----	--------	-------	------	---	---	---

* recommended for 2 log removal

All-Poly

WB 5x170FL	5	375	30-3/4	7-3/4	300**	500	380	180
------------	---	-----	--------	-------	-------	-----	-----	-----

** based on 1, 5, 10, 20 and 50 micron ratings

Carbon Block

WB 5x170FL	5	450	30-3/4	7-3/4	75***	-	-	-
------------	---	-----	--------	-------	-------	---	---	---

*** recommended flow for maximum chlorine removal

Flow rates shown above are for guidelines only. Actual flow rates are based on cartridge type, micron rating, viscosity, solids content and various other factors. For complete flow and pressure and pressure drop information, please refer to your cartridge manufacturer guidelines.

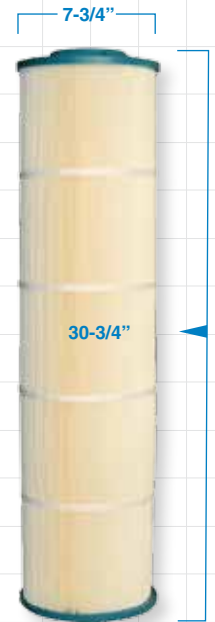

Hurricane® Cartridge
Length and O.D.

Ordering Information

Filter Model	Height	Width	Diameter	Inlet	Outlet	Pipe Size I/O NPS	Drain Size NPT	Floor Space	Service Height	Shipping Wt. Lbs.
WB 5x170FL	46"	26"	26"	5"	5"	4" Flange	1-1/2"	28"x28"	85"	260

Filter Specifications

- ▶ Electropolished 304 stainless steel
- ▶ Standpipes - CPVC standard
- ▶ Inlet/Outlet - 4" flanged standard
- ▶ O-ring housing seal - Buna-N standard, EPDM, Viton optional
- ▶ Pressure - Up to 125 psi (8.6 bar) max.
- ▶ Temperature - Up to 140°F (60°C)

Pressure Drop

Pressure Drop vs. Flow Rate

The total head loss data shown indicates pressure drop with WB 5x170FL WaterBetter® filter housing and 20-micron filter cartridges in clean water.

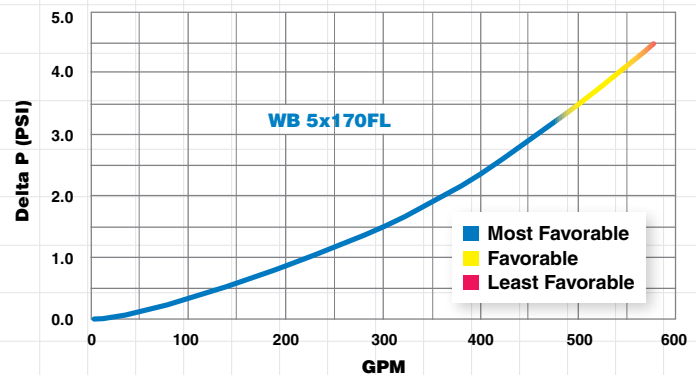

For additional information, please refer to the "Installation & Operation Manual" for WB 5x170FL WaterBetter® Filter Housings.

Note: This publication is to be used as a guide. The data within has been obtained from many sources and is considered to be accurate. Harmsco does not assume liability for the accuracy and/or completeness of this data. Changes to the data can be made without notification. Temperature, Pressure, Flow Rates, Differential Pressures, Chemical Combinations and other unknown factors can affect performance in unknown ways. **Limited Warranty:** Harmsco warrants their products to be free of material and workmanship defects. Determination of suitability of Harmsco products for uses and applications contemplated by Buyer shall be the sole responsibility of Buyer. The end user/installer/buyer shall be liable for the product's performance and suitability regarding their specific intended applications. End users should perform their own tests to determine suitability for each application.



HARMSCO® Filtration Products

P.O. Box 14066, North Palm Beach, FL 33408

(561) 848-9628 • Toll-free: (800) 327-3248 • Fax: (561) 845-2474 • E-mail: sales@harmsco.com

www.harmsco.com



Made in USA

© Harmsco, Inc. 05D 06 7/11

Filter Housings – Tab 3

HMC Filter Housings

HMC Filter Housings

- ▶ Built to ASME design standards
- ▶ U-Stamp option available
- ▶ Offered in 304 and 316 stainless steel
- ▶ Standard hold down plates to accept DOE, 222/Flat and 222/Fin style cartridges
- ▶ Flow rates up to 1,400 GPM



Sizing Info:

HMC housings accept 2-1/2" and 2-3/4" O.D. plus 30" and 40" lengths; housings accept DOE and 222 End Caps as standard

Cartridge Options

Premium & WaterBetter® Cartridges (Tab 22)

- ▶ Pleated cartridges designed for Harmsco® HMC
- ▶ Premium Series offers 6 sq. ft. media per 9-3/4" cartridge
- ▶ WaterBetter® Series offers 4 sq. ft. media per 9-3/4" cartridge
- ▶ NSF-61 Listed

Premium 701 Series Cartridges (Tab 23)

- ▶ 2-1/2" O.D. pleated cartridges designed for Harmsco® and competitive filter housings
- ▶ NSF-61 Listed
- ▶ All cartridges shrink wrapped
- ▶ Polyester, Harmsco-Free and Poly-Pleat™ media available

All-Poly/High Purity Cartridges (Tab 28)

- ▶ Available in: Polypropylene - PP; Polyethersulfone - PES Membrane; Microfiberglass - FG; Nylon 6,6 - NY and Plus + Nylon 6,6 - NYP; Teflon - TF Membrane

Multi Cartridge Housings

Municipal/Industrial

Designed to accept 30" or 40" Nominal Length Cartridges.

- HMC Series Filter Housings are designed with a universal bottom plate to accept 2-3/4" or 2-1/2" diameter cartridges with DOE (double open end), 222/Flat and 222/Fin end cap configurations.

Features

- ▶ 304 stainless steel construction, standard
- ▶ 304 stainless steel components - includes cap/spring and V post, standard
- ▶ 150 PSI (10.3 bar) pressure rating
- ▶ Multiple hold-down plates to accept DOE, 222/Flat and 222/Fin style cartridges
- ▶ Built to ASME design standards
- ▶ Bead blast finish, standard
- ▶ Adjustable top plates to accept 30" or 40" nominal length cartridges
- ▶ Assisted davit arm closure - 12 round and larger
- ▶ Two gauge ports - inlet and outlet sides
- ▶ Two drains provided - inlet and outlet fluids

Options:

ASME Code U-stamp
Electropolished
316 stainless steel construction



Applications

- ▶ Industrial Waste Water Treatment
- ▶ Industrial Process (High Purity) Applications
- ▶ Ground Water Under Direct Influence (GUDI)
- ▶ Surface Water Treatment Rule (SWTR) LT2
- ▶ Reverse Osmosis Pre-filtration
- ▶ Municipal Drinking Water
- ▶ Cooling Tower Filtration
- ▶ Ground Water Remediation

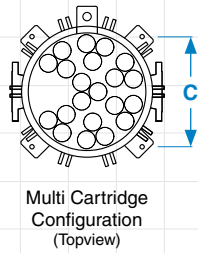
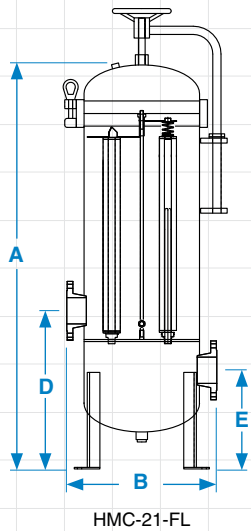

Multi Cartridge Configuration (Topview)



HMC-5



HMC-7



HMC-12-FL



HMC-21-FL

Not Shown: HMC-36-FL, HMC-51-FL

Ordering Information

Filter Model	Max Flow Rate* (GPM)	Max Flow Rate* (LPM)	Max Flow Rate* (M ³ /Hr)	A Filter Ht	B Width	C Diameter	D Inlet	E Outlet	I/O Size	I/O Type	Drain Size	Weight (lbs)
HMC-5	150	508	36	55.4"	13"	8.1"	13.8"	9.8"	2"	FNPT	1" FNPT	104
HMC-7	200	757	42	56.9"	14.4"	9.2"	14-1/2"	10-3/8"	2"	FNPT	1" FNPT	130
HMC-12-FL	300	1,135	75	66.9"	18-7/8"	13-9/16"	19-11/16"	12-13/16"	3"	FL	1" FNPT	425
HMC-21-FL	600	2,271	150	71.9"	23"	23"	24-1/4"	15-1/8"	4"	FL	1" FNPT	560
HMC-36-FL	1,000	3,785	227	76.1"	27-1/2"	28"	27-1/2"	16-7/8"	6"	FL	1" FNPT	695
HMC-51-FL	1,400	5,299	318	78"	31-5/16"	22-15/16"	29-5/8"	17-5/8"	6"	FL	1.5" FNPT	832

*Flow rates shown above are for guidelines only. Actual flow rates are based on cartridge type, micron rating, viscosity, solids content and other factors. For complete flow and pressure drop information please refer to your cartridge manufacturer guidelines.

Specifications

- ▶ **Finish** - bead blast
- ▶ **Inlet/Outlet** - FNPT on HMC-5, -7; flanged on HMC-12, -21, -36 and -51
- ▶ **Construction** - 304 stainless steel; built to ASME design standards
- ▶ **Pressure** - up to 150 PSI (10.3 bar) max
- ▶ **Closure** - BUNA o-ring housing seal with swing bolt closure
- ▶ **Temperature** - up to 250°F (121°C), filter housing only

End Caps

Harmsco® Multi Cartridge Housings come standard with alternative compression/hold down plates that allow for the use of DOE, 222/Flat or 222/Fin end caps.



DOE



222



Fin

Pressure Drop

Based on 2", 4" and 6" inlet/outlet housings, without cartridges.

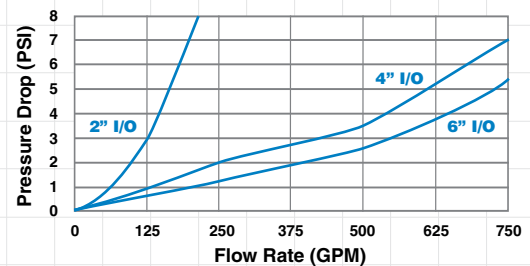

Note: This publication is to be used as a guide. The data within has been obtained from many sources and is considered to be accurate. Harmsco does not assume liability for the accuracy and/or completeness of this data. Changes to the data can be made without notification. Temperature, Pressure, Flow Rates, Differential Pressures, Chemical Combinations and other unknown factors can affect performance in unknown ways. **Limited Warranty:** Harmsco warrants their products to be free of material and workmanship defects. Determination of suitability of Harmsco products for uses and applications contemplated by Buyer shall be the sole responsibility of Buyer. The end user/installer/buyer shall be liable for the product's performance and suitability regarding their specific intended applications. End users should perform their own tests to determine suitability for each application.



HARMSCO® Filtration Products

P.O. Box 14066, North Palm Beach, FL 33408

(561) 848-9628 • Toll-free: (800) 327-3248 • Fax: (561) 845-2474 • E-mail: sales@harmsco.com

www.harmsco.com



Filter Housings – Tab 4

HIF Filter Housings

- ▶ Patented Up-flow design
- ▶ Offered in 304 and 316 stainless steel
- ▶ Coated option available
- ▶ Flow rates up to 800 GPM



Sizing Info:

HIF housings accept 2-1/2" and 2-3/4" O.D. cartridges and 9-3/4", 19-1/2" and 29-1/4" lengths; DOE end caps only

Cartridge Options

Premium & WaterBetter® Cartridges (Tab 22)

- ▶ Pleated cartridges designed for Harmsco® HIF, Band Clamp and single cartridge housings
- ▶ Premium Series offers 6 sq. ft. media per 9-3/4" cartridge
- ▶ WaterBetter® Series offers 4 sq. ft. media per 9-3/4" cartridge
- ▶ NSF-61 Listed

Premium 701 Series Cartridges (Tab 23)

- ▶ 2-1/2" O.D. pleated cartridges designed for Harmsco® and competitive filter housings
- ▶ NSF-61 Listed
- ▶ All cartridges shrink wrapped
- ▶ Polyester, Harmsco-Free and Poly-Pleat™ media available

SureSafe™ Cartridges (Tab 25)

- ▶ Antimicrobial cartridge media prohibits growth of bacteria and mold on filter cartridge
- ▶ Offered in 20 and 50 micron ratings and a wide range of cartridge sizes
- ▶ Agion Silver Zeolite is FDA tested and registered with the EPA

Premium Poly-Pleat™ Cartridges (Tab 26)

- ▶ Pleated one micron absolute cartridges for safe, cyst-free drinking water
- ▶ NSF-61 Listed
- ▶ Available in a wide range of cartridge sizes

Carbon Cartridges (Tab 27)

- ▶ For high chlorine, taste, odor, lead, THM and organic chemical removal
- ▶ Available in a wide range of cartridge sizes, including Hurricane® 170 Series
- ▶ NSF-42 Listed

All-Poly/High Purity Cartridges (Tab 28)

- ▶ Available in: Polypropylene - PP; Polyethersulfone - PES Membrane; Microfiberglass - FG; Nylon 6,6 - NY and Plus + Nylon 6,6 - NYP; Teflon - TF Membrane
- ▶ Available in DOE Cap
- ▶ Available in micron ratings 0.2, 0.45, 1 and 5

Note: This publication is to be used as a guide. The data within has been obtained from many sources and is considered to be accurate. Harmsco does not assume liability for the accuracy and/or completeness of this data. Changes to the data can be made without notification. Temperature, Pressure, Flow Rates, Differential Pressures, Chemical Combinations and other unknown factors can affect performance in unknown ways. **Limited Warranty:** Harmsco warrants their products to be free of material and workmanship defects. Determination of suitability of Harmsco products for uses and applications contemplated by Buyer shall be the sole responsibility of Buyer. The end user/installer/buyer shall be liable for the product's performance and suitability regarding their specific intended applications. End users should perform their own tests to determine suitability for each application.

Up-Flow Cartridge Housings

Commercial/Industrial

Up-Flow Filtration

A design so superior it's patented.



Certified to
ANSI-NSF 61

- This product is designed with a patented Up-flow technology which prevents the accumulation of air inside the filter housing keeping the filter operating at 100%.

Features

- ▶ 304 stainless steel construction, standard
- ▶ Electropolished finish, standard
- ▶ 150 psi (10.3 bar) pressure rating
- ▶ Flow Rates up to 800 gpm
- ▶ All filter housings hydrostatically tested
- ▶ Easy cartridge installation, removal and service
- ▶ Individual studs for safe, secure lid closure
- ▶ Extensive choice of cartridge micron ratings and media

Options:

316 stainless steel
Chemical resistant coating
Flanged options on HIF 24, HIF 42,
HIF 75 and HIF 100



HIF 7

HIF 24

HIF 200FL

Not shown:

HIF 14, HIF 16, HIF 21, HIF 42, HIF 75, HIF 100 and HIF 150FL

Applications

- ▶ Residential and Commercial Drinking Water
- ▶ Cooling Tower Filtration
- ▶ Process Water
- ▶ Reverse Osmosis Pre-filtration
- ▶ Ground Water Remediation
- ▶ Utility Water
- ▶ Industrial Waste Water Treatment
- ▶ Surface Water Treatment Rule (SWTR) LT2





Certified to
ANSI-NSF 61



Cartridge Cluster Filters

All cartridges in our 7, 14, 16, 21 and 24 models are arranged in a single "cartridge cluster," so all cartridges are removed at one time for easy cartridge cleaning or replacement.

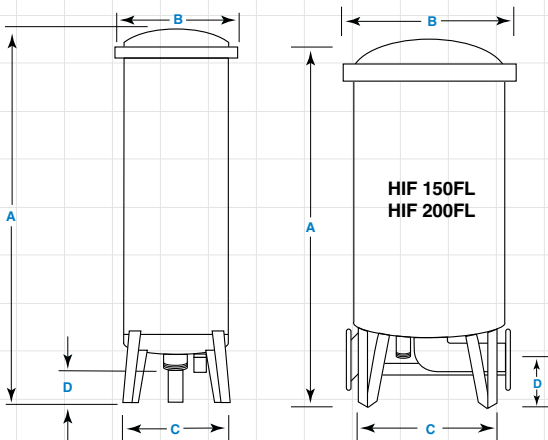

Dimensions

Filter Model	A Height	B Diameter	C Leg Width	D Height	Service Ht.	Inlet/Outlet	Drain
HIF 7	19-1/2"	13"	13"	3-1/2"	35"	1-1/2" NPT	1" NPT
HIF 14	28"	13"	13"	3-1/2"	48"	1-1/2" NPT	1" NPT
HIF 16	28"	13"	13"	4"	48"	2" NPT	1" NPT
HIF 21	37"	13"	13"	3-1/2"	68"	1-1/2" NPT	1" NPT
HIF 24	37"	13"	13"	4"	68"	2" NPT	1" NPT
HIF 42	40"	18"	18"	5-3/8"	68"	2" NPT	1" NPT
HIF 75	42"	20"	20"	6-3/8"	70"	3" NPT	1-1/2" NPT
HIF 100	52"	20"	20"	5-7/8"	87"	3" NPT	1-1/2" NPT
HIF 150FL	48"	28"	28"	5-3/16"	76"	4" flange	1-1/2" NPT
HIF 200FL	58"	28"	28"	5-3/16"	93"	4" flange	1-1/2" NPT

Flanged options on HIF 24, HIF 42, HIF 75 and HIF 100

Ordering Information

Filter Model	HIF 7	HIF 14	HIF 16	HIF 21	HIF 24	HIF 42	HIF 75	HIF 100	HIF 150FL	HIF 200FL
Flow Rate* (GPM)	Up to 30	Up to 60	Up to 75	Up to 90	Up to 100	Up to 175	Up to 300	Up to 400	Up to 600	Up to 800
Flow Rate* (LPM)	Up to 113	Up to 226	Up to 284	Up to 340	Up to 397	Up to 662	Up to 1,135	Up to 1,514	Up to 2,271	Up to 3,028
Flow Rate* (M³/HR)	Up to 7	Up to 14	Up to 17	Up to 20	Up to 23	Up to 40	Up to 68	Up to 91	Up to 136	Up to 181
Cartridges	7 - 9-3/4" "Singles"	7 - 19-1/2" "Doubles"	8 - 19-1/2" "Doubles"	7 - 29-1/4" "Triples"	8 - 29-1/4" "Triples"	14 - 29-1/4" "Triples"	25 - 29-1/4" "Triples"	50 - 19-1/2" "Doubles"	50 - 29-1/4" "Triples"	100 - 19-1/2" "Doubles"

*Flow rates shown above are for guidelines only. Actual flow rates are based on cartridge type, micron rating, viscosity, solids content and a number of other factors. For complete flow and pressure drop information please refer to your cartridge manufacturer guidelines.

Specifications

- ▶ **Filter Vessel/Metal Components** - 304 stainless steel, electropolished for increased resistance to corrosion
- ▶ **Holding/Lifting Rods, Standpipes and Pipe Caps** - CPVC, standard models; 304 stainless steel for All-Stainless models
- ▶ **Rim Gaskets** - EPDM, standard; Buna-N, Viton available
- ▶ **O-rings** - Buna-N, standard; EPDM, Viton available
- ▶ **Bottom Seals** - natural gum rubber, standard; EPDM, Viton available
- ▶ **Pressure** - rated for pressures to 150 PSI (10.3 bar) max
- ▶ **Temperature** - rated to 140°F (60°C) with CPVC rods, pipe caps, standpipes and standard Harmsco cartridges; to 200°F (93°C) for all stainless models with stainless steel rods, pipe caps and standpipes, and Harmsco High-Temp cartridges
- ▶ **Flow** - up to 800 gpm; typical flow rates are 4-6 gpm per single length (9-3/4")
- ▶ **Wing Nuts** - brass; optional brass hex nuts and stainless steel flat washers

Note: This publication is to be used as a guide. The data within has been obtained from many sources and is considered to be accurate. Harmsco does not assume liability for the accuracy and/or completeness of this data. Changes to the data can be made without notification. Temperature, Pressure, Flow Rates, Differential Pressures, Chemical Combinations and other unknown factors can affect performance in unknown ways. **Limited Warranty:** Harmsco warrants their products to be free of material and workmanship defects. Determination of suitability of Harmsco products for uses and applications contemplated by Buyer shall be the sole responsibility of Buyer. The end user/installer/buyer shall be liable for the product's performance and suitability regarding their specific intended applications. End users should perform their own tests to determine suitability for each application.



HARMSCO® Filtration Products

P.O. Box 14066, North Palm Beach, FL 33408

(561) 848-9628 • Toll-free: (800) 327-3248 • Fax: (561) 845-2474 • E-mail: sales@harmsco.com

www.harmsco.com



Made in USA

© Harmsco, Inc. 01B 10 7/11

Filter Housings – Tab 5

BC Band Clamp Housings

BC Band Clamp Housings

- ▶ Patented Up-flow design
- ▶ Offered in 304 and 316 stainless steel
- ▶ Flow rates up to 126 GPM
- ▶ FNPT, BSTP, Flange and Victaulic connections available



Sizing Info:

BC housings accept 2-1/2" and 2-3/4" O.D. cartridges in 9-3/4", 10", 19-1/2", 20", 29-1/4" and 30" lengths; DOE end caps only

Cartridge Options

Premium & WaterBetter® Cartridges (Tab 22)

- ▶ Pleated cartridges designed for Harmsco® HIF, Band Clamp and single cartridge housings
- ▶ Premium Series offers 6 sq.ft. media per 9-3/4" cartridge
- ▶ WaterBetter® Series offers 4 sq.ft. media per 9-3/4" cartridge
- ▶ NSF-61 Listed

Premium 701 Series Cartridges (Tab 23)

- ▶ 2-1/2" O.D. pleated cartridges designed for Harmsco® and competitive filter housings
- ▶ NSF-61 Listed
- ▶ All cartridges shrink wrapped

SureSafe™ Cartridges (Tab 25)

- ▶ Antimicrobial cartridge media prohibits growth of bacteria and mold on filter cartridge
- ▶ Offered in 20 and 50 micron ratings and a wide range of cartridge sizes
- ▶ Agion Silver Zeolite is FDA tested and registered with the EPA

Premium Poly-Pleat™ Cartridges (Tab 26)

- ▶ Pleated one micron absolute cartridges for safe, cyst-free drinking water
- ▶ NSF-61 Listed
- ▶ Available in a wide range of cartridge sizes

Carbon Cartridges (Tab 27)

- ▶ For high chlorine, taste, odor, lead, THM and organic chemical removal
- ▶ Available in a wide range of cartridge sizes, including Hurricane® 170 Series
- ▶ NSF-42 Listed

All-Poly/High Purity Cartridges (Tab 28)

- ▶ Available in: Polypropylene - PP; Polyethersulfone - PES Membrane; Microfiberglass - FG; Nylon 6,6 - NY and Plus + Nylon 6,6 - NYP; Teflon - TF Membrane

Band Clamp Housings

Commercial Grade

Up-Flow Filtration

A design so superior it's patented.

- This product is designed with a patented Up-flow technology which prevents the accumulation of air inside the filter housing keeping the filter operating at 100%.

Features

- ▶ 304 stainless steel construction, standard
- ▶ Electropolished finish, standard
- ▶ 150 psi (10.3 bar) pressure rating
- ▶ Flow rates up to 126 gpm
- ▶ All filter housings hydrostatically tested
- ▶ Stainless steel cartridge lifters for easy cartridge removal
- ▶ Adjustable top plates to accept various length cartridges
- ▶ Two drains provided - inlet and outlet fluids
- ▶ Extensive choice of cartridge micron ratings and media
- ▶ Integral mounting legs, drill in place

Options:

316 stainless steel
Sanitary, BSTP or victaulic connections



Models BC4-1, BC4-2, BC4-3, BC6-1, BC6-2, BC6-3

Applications

- ▶ Commercial/Residential Drinking Water
- ▶ Cooling Tower Filtration
- ▶ Process Water
- ▶ Reverse Osmosis Pre-Filtration
- ▶ Ground Water Remediation
- ▶ Utility Water
- ▶ Industrial Waste Water Treatment
- ▶ Ground Water Under Direct Influence (GUDI)



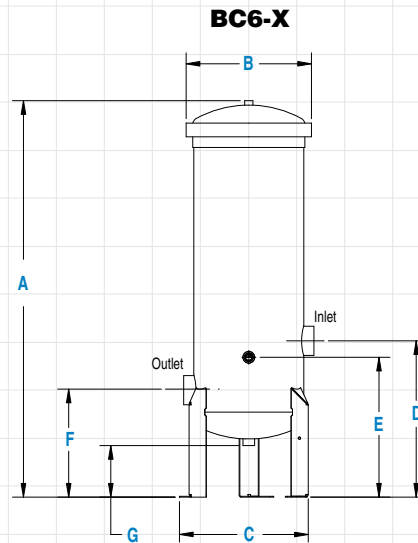
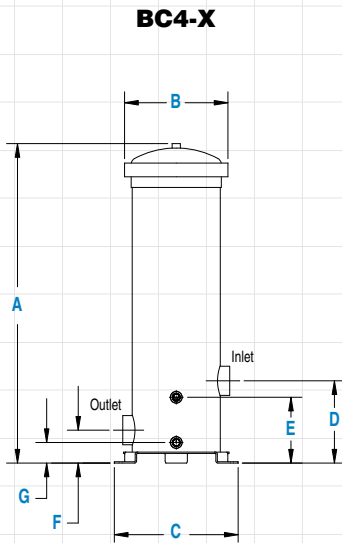

Band Clamp Assembly

Ordering Information

Filter Model	Rec'd Flow Rate*(GPM)	Max Flow Rate*(GPM)	Max Flow Rate*(LPM)	Max Flow Rate*(M ³ /Hr)	A Height	B Diameter	C Width	D Height	E Height	F Height	G Height	I/O FNPT	No. of Cartridges	Cartridge Height (in)	Service Height
BC4-1	12	25	95	5	19-1/2"	9-1/2"	11-1/2"	7-1/2"	6"	3"	1-7/16"	2"	4	9 3/4 or 10	28"
BC4-2	24	50	190	12	29-1/4"	9-1/2"	11-1/2"	7-1/2"	6"	3"	1-7/16"	2"	4	19 1/2 or 20	47"
BC4-3	36	75	285	17	39"	9-1/2"	11-1/2"	7-1/2"	6"	3"	1-7/16"	2"	4	29 1/4 or 30	67"
BC6-1	18	42	159	10	25-1/2"	11-1/2"	12"	14-1/4"	12-3/4"	9-3/4"	4-3/4"	2"	6	9 3/4 or 10	35"
BC6-2	36	84	318	19	35-1/4"	11-1/2"	12"	14-1/4"	12-3/4"	9-3/4"	4-3/4"	2"	6	19 1/2 or 20	54"
BC6-3	54	126	477	29	45"	11-1/2"	12"	14-1/4"	12-3/4"	9-3/4"	4-3/4"	2"	6	29 1/4 or 30	74"

*Flow rates shown above are for guidelines only. Actual flow rates are based on cartridge type, micron rating, viscosity, solids content and a number of other factors. For complete flow and pressure drop information please refer to your cartridge manufacturer guidelines.

Specifications

- ▶ **Finish** - Electropolish standard; poly coat optional
- ▶ **Inlet/Outlet** - 2" FNPT; sanitary, BSTP, victaulic connections optional
- ▶ **Closure** - Band clamp closure, O-rings Buna-N
- ▶ **Pressure** - Up to 150 psi (10.3 bar) max
- ▶ **Construction** - 304 stainless steel standard; 316 optional
- ▶ **Temperature** - up to 250°F(121°C), housing only

Note: This publication is to be used as a guide. The data within has been obtained from many sources and is considered to be accurate. Harmsco does not assume liability for the accuracy and/or completeness of this data. Changes to the data can be made without notification. Temperature, Pressure, Flow Rates, Differential Pressures, Chemical Combinations and other unknown factors can affect performance in unknown ways. **Limited Warranty:** Harmsco warrants their products to be free of material and workmanship defects. Determination of suitability of Harmsco products for uses and applications contemplated by Buyer shall be the sole responsibility of Buyer. The end user/installer/buyer shall be liable for the product's performance and suitability regarding their specific intended applications. End users should perform their own tests to determine suitability for each application.



HARMSCO® Filtration Products

P.O. Box 14066, North Palm Beach, FL 33408

(561) 848-9628 • Toll-free: (800) 327-3248 • Fax: (561) 845-2474 • E-mail: sales@harmsco.com

www.harmsco.com



Made in USA

© Harmsco, Inc. 16A 08 7/11

Poly Coat Filter Housings

Universal Design

Multi-Round Cartridge Housings

- Harmsco® HBC filter housings are designed with a universal bottom plate to accept 2-1/2" or 2-3/4" diameter cartridges with DOE (double open end), 222/Flat and 222/Fin end cap configurations.

Features

- ▶ 304 stainless steel construction, standard
- ▶ 304 stainless steel cap/spring assemblies, standard
- ▶ 150 PSI (10.3 bar) pressure rating
- ▶ Universal bottom seal cups to accept DOE, 222/Flat or 222/Fin style cartridges
- ▶ Exterior poly coat finish, standard
- ▶ Heavy duty legs included on all models
- ▶ Bottom drain provided
- ▶ Vented lid
- ▶ Two gauge ports - inlet and outlet side

Options:

316 stainless steel construction
Alternative O-ring material



Applications

- ▶ Commercial Drinking Water
- ▶ Cooling Tower Filtration
- ▶ Industrial Waste Water Treatment
- ▶ Reverse Osmosis Pre-filtration
- ▶ Ground Water Remediation
- ▶ Process Water
- ▶ Utility Water
- ▶ Well Water



Drawings available upon request.

End Caps

Harmsco® HBC Cartridge Housings come standard with alternative compression/hold down plates that allow for the use of DOE, 222/Flat or 222/Fin end caps.



Ordering Information

Uses 2-1/2" or 2-3/4" O.D. Cartridges

Filter Model	Rec'd Flow Rate* (GPM)	Max Flow Rate* (GPM)	Max Flow Rate* (LPM)	Max Flow Rate* (M ³ /Hr)	Inlet/Outlet Connection	No. of Cartridges	Cartridge Service Height	Housing Service Ht. (in.)	Housing Wt. (lbs.)	
4R	HBC 4-1	20	28	106	6	2" MNPT	4	9-3/4" or 10"	34	37
	HBC 4-2	40	56	212	13	2" MNPT	4	19-1/2" or 20"	54	41
	HBC 4-3	58-60	84	318	19	2" MNPT	4	29-1/4" or 30"	74	49
	HBC 4-4	80	112	424	25	2" MNPT	4	40"	94	60
5R	HBC 5-1	25	35	132	8	2" MNPT	5	9-3/4" or 10"	34	37
	HBC 5-2	50	70	265	16	2" MNPT	5	19-1/2" or 20"	54	41
	HBC 5-3	75	105	397	24	2" MNPT	5	29-1/4" or 30"	74	49
	HBC 5-4	100	140	530	32	2" MNPT	5	40"	94	60
7R	HBC 7-1	35	49	185	11	2" MNPT	7	9-3/4" or 10"	35	49
	HBC 7-2	70	98	371	22	2" MNPT	7	19-1/2" or 20"	55	54
	HBC 7-3	105	147	556	33	2" MNPT	7	29-1/4" or 30"	75	68
	HBC 7-4	138	196	742	45	2" MNPT	7	40"	95	73
12R	HBC 12-3	178-180	252	954	57	3" Flange	12	29-1/4" or 30"	81	128
	HBC 12-4	235	336	1,272	76	3" Flange	12	40"	101	139
22R	HBC 22-3	325	462	1,749	105	4" Flange	22	29-1/4" or 30"	75	206
	HBC 22-4	435	616	2,332	140	4" Flange	22	40"	95	223

*Flow rates shown above are for guidelines only. Actual flow rates are based on cartridge type, micron rating, viscosity, solids content and various other factors. For complete flow and pressure drop information please refer to your cartridge manufacturer guidelines.

Note: add suffix "-6" for 316 option. Example: HBC 4-1-6 (4 round, 9-3/4" or 10" cartridge, 316 stainless steel).

Specifications

- ▶ **Finish** - Poly Coat standard (exterior only)
- ▶ **Inlet/Outlet** - 2" MNPT, 3" flange, 4" flange
- ▶ **Construction** - 304 stainless steel standard, 316 optional
- ▶ **Closure** - Band clamp closure, O-ring, Buna-N
- ▶ **Pressure** - up to 150 PSI (10.3 bar) max
- ▶ **Temperature** - up to 250°F (121°C); filter housing only

Note: This publication is to be used as a guide. The data within has been obtained from many sources and is considered to be accurate. Harmsco does not assume liability for the accuracy and/or completeness of this data. Changes to the data can be made without notification. Temperature, Pressure, Flow Rates, Differential Pressures, Chemical Combinations and other unknown factors can affect performance in unknown ways. **Limited Warranty:** Harmsco warrants their products to be free of material and workmanship defects. Determination of suitability of Harmsco products for uses and applications contemplated by Buyer shall be the sole responsibility of Buyer. The end user/installer/buyer shall be liable for the product's performance and suitability regarding their specific intended applications. End users should perform their own tests to determine suitability for each application.



HARMSCO® Filtration Products

P.O. Box 14066, North Palm Beach, FL 33408

(561) 848-9628 • Toll-free: (800) 327-3248 • Fax: (561) 845-2474 • E-mail: sales@harmsco.com

www.harmsco.com



Filter Housings – Tab 6

FSSS Single Cartridge Housings

FSSS Single Cartridge Housings

- ▶ Designed for 300 PSI
- ▶ Offered in 304 and 316 stainless steel
- ▶ DOE or 222/Flat configurations available



Sizing Info:

FSSS housings accept 2-1/2" and 2-3/4" O.D. cartridges in 9-3/4", 10" and 20" lengths; DOE and 222/Flat end options

Cartridge Options

Premium & WaterBetter® Cartridges (Tab 22)

- ▶ Pleated cartridges designed for Harmsco® HIF, Band Clamp and single cartridge housings
- ▶ Premium Series offers 6 sq.ft. media per 9-3/4" cartridge
- ▶ WaterBetter® Series offers 4 sq.ft. media per 9-3/4" cartridge
- ▶ NSF-61 Listed

Premium 701 Series Cartridges (Tab 23)

- ▶ 2-1/2" O.D. pleated cartridges designed for Harmsco® and competitive filter housings
- ▶ NSF-61 Listed
- ▶ All cartridges shrink wrapped
- ▶ Available in 9-3/4", 10", 20", 30" and 40" cartridge lengths

SureSafe™ Cartridges (Tab 25)

- ▶ Antimicrobial cartridge media prohibits growth of bacteria and mold on filter cartridge
- ▶ Offered in 20 and 50 micron ratings and a wide range of cartridge sizes
- ▶ Agion Silver Zeolite is FDA tested and registered with the EPA

Premium Poly-Pleat™ Cartridges (Tab 26)

- ▶ Pleated one micron absolute cartridges for safe, cyst-free drinking water
- ▶ NSF-61 Listed
- ▶ Available in a wide range of cartridge sizes

Carbon Cartridges (Tab 27)

- ▶ For high chlorine, taste, odor, lead, THM and organic chemical removal
- ▶ Available in a wide range of cartridge sizes, including Hurricane® 170 Series
- ▶ NSF-42 Listed

All-Poly/High Purity Cartridges (Tab 28)

- ▶ Available in: Polypropylene - PP; Polyethersulfone - PES Membrane; Microfiberglass - FG; Nylon 6,6 - NY and Plus + Nylon 6,6 - NYP; Teflon - TF Membrane
- ▶ Available in DOE, 222 w/Fin, 222 w/Flat Cap, 226 w/Flat Cap, 226 w/Fin, 213 Internal O-Ring
- ▶ Available in Hurricane® sizes 40, 90 and 170, and in micron ratings 0.2, 0.45, 1, 5, 10, 20 and 50

Single Cartridge Housings

Commercial/Industrial

Designed for 300 psi in 304 or 316 stainless steel.

- FSSS Series Filter Housings are designed with a double o-ring compression which allows for positive sealing and easy access. Offered in DOE (double open end) or 222/Flat configurations.

Features

- ▶ 304 or 316 stainless steel construction
- ▶ 300 PSI (20.7 bar) pressure rating
- ▶ Electro-polished finish
- ▶ Offered in Double Open End or 222/Flat configurations
- ▶ Double o-ring compression seal for easy change out
- ▶ Includes 1/8" NPT vent and 1/8" NPT drain
- ▶ Inline design for easy installation
- ▶ Knife edge seal at both cartridge ends to eliminate by-pass for DOE cartridges
- ▶ Standard with wrench and mounting bracket



FSSS-1
Series



FSSS-2
Series

Applications

- ▶ Food & Beverage Filtration
- ▶ Reverse Osmosis Pre-filtration
- ▶ Process Water Filtration
- ▶ Cutting Fluids
- ▶ Lubricants
- ▶ Plating Solutions
- ▶ High Purity Water
- ▶ Inks

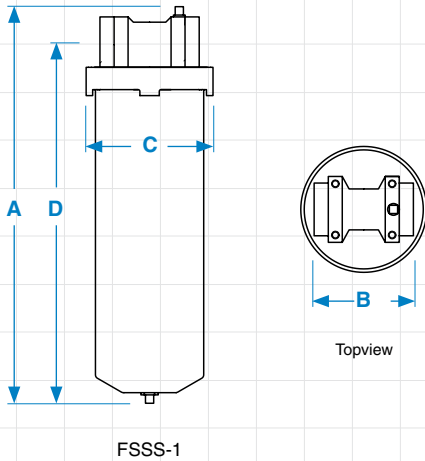

FSSS-1 Series



FSSS-2 Series

Optional Housing Selection for different style End Cap Configurations



222/Flat



222/Flat



DOE

Ordering Information

Filter Model	Length	Inlet/Outlet Pipe Size	End Configuration	Material	A Filter Ht.	B I/O Width	C Diameter	D Inlet
FSSS-1A	9-3/4"	3/4"	DOE	316 SS	13"	3.2"	4.06"	11.84
FSSS-1B	9-3/4"	3/4"	DOE	304 SS	13"	3.2"	4.06"	11.84
FSSS-1A-222	9-3/4"	3/4"	222/Flat	316 SS	13"	3.2"	4.06"	11.84
FSSS-1B-222	9-3/4"	3/4"	222/Flat	304 SS	13"	3.2"	4.06"	11.84
FSSS-2A	20"	1"	DOE	316 SS	23"	3.2"	4.06"	21.84
FSSS-2B	20"	1"	DOE	304 SS	23"	3.2"	4.06"	21.84
FSSS-2A-222	20"	1"	222/Flat	316 SS	23"	3.2"	4.06"	21.84
FSSS-2B-222	20"	1"	222/Flat	304 SS	23"	3.2"	4.06"	21.84

Specifications

- ▶ **Finish** - electro-polished
- ▶ **Inlet/Outlet** - 3/4" on 9-3/4" housings and 1" on 20" housings
- ▶ **Construction** - 304 or 316 stainless steel
- ▶ **Pressure** - up to 300 PSI (20.7 bar) max
- ▶ **Temperature** - up to 250°F (121°C) (filter housing only)
- ▶ **O-ring Closure Seal** - silicone (standard)

Cap

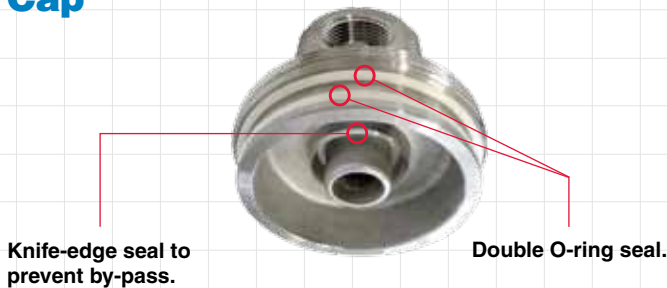

Pressure Drop

Based on 3/4" and 1" inlet/outlet housings, without cartridges.

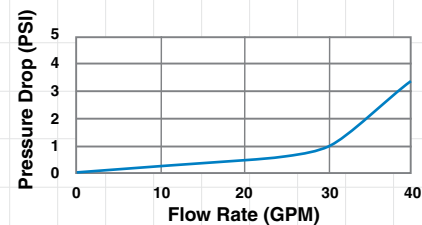

Note: This publication is to be used as a guide. The data within has been obtained from many sources and is considered to be accurate. Harmsco does not assume liability for the accuracy and/or completeness of this data. Changes to the data can be made without notification. Temperature, Pressure, Flow Rates, Differential Pressures, Chemical Combinations and other unknown factors can affect performance in unknown ways. **Limited Warranty:** Harmsco warrants their products to be free of material and workmanship defects. Determination of suitability of Harmsco products for uses and applications contemplated by Buyer shall be the sole responsibility of Buyer. The end user/installer/buyer shall be liable for the product's performance and suitability regarding their specific intended applications. End users should perform their own tests to determine suitability for each application.



HARMSCO® Filtration Products

P.O. Box 14066, North Palm Beach, FL 33408

(561) 848-9628 • Toll-free: (800) 327-3248 • Fax: (561) 845-2474 • E-mail: sales@harmsco.com

www.harmsco.com



Filter Housings – Tab 7

HMB, HSB and BCB Bag Housings

HMB, HSB and BCB Bag Housings

- ▶ Offered in 304 and 316 stainless steel
- ▶ U-Stamp option available (HMB, HSB)
- ▶ Standard #1, #2 and Extended bag options
- ▶ Flow rates up to 2,400 GPM



Sizing Info:

HMB, HSB and BCB accept “V” seal ring bags or metal O-ring bags, STD #1 and STD #2; EXT #1 and EXT #2 options

Cartridge Options

Liquid Filter Bags

(Tab 30)

- ▶ “V” Seal Ring Bags available to prevent by-pass
- ▶ Polypropylene and Polyester options available
- ▶ Broad chemical compatibility
- ▶ Industry #1, #2 and EXT extended bag sizes available

HARMSCO®

Multi Bag Housings

HMB

Municipal/Industrial

Designed with **Snap Fit “V” Ring Bag Seal** to prevent by-pass.

- HMB Series Bag Housings are designed for high flow, high contaminant removal. Manufactured to ASME design standards for durability and long equipment life.

Features

- ▶ 304 stainless steel construction, standard
- ▶ 304 stainless steel perforated baskets, standard
- ▶ 150 PSI (10.3 bar) pressure rating
- ▶ Built to ASME design standards
- ▶ Bead blast finish, standard
- ▶ Designed to accept standard #2 Snap Fit “V” Ring or steel ring bags
- ▶ Two gauge ports - inlet and outlet sides
- ▶ Assisted davit arm with eye-nut closure

Options:

ASME Code U-stamp
316 stainless steel construction



HMB-4-FL

HMB-6-FL

Applications

- ▶ Paint
- ▶ Process Water
- ▶ Plating Solutions
- ▶ Coatings
- ▶ Industrial Waste Water Treatment
- ▶ Lubricants
- ▶ Solvents
- ▶ Hydraulic Fluids
- ▶ Cutting Fluids
- ▶ Ground Water Remediation



HARMSCO® Filtration Products



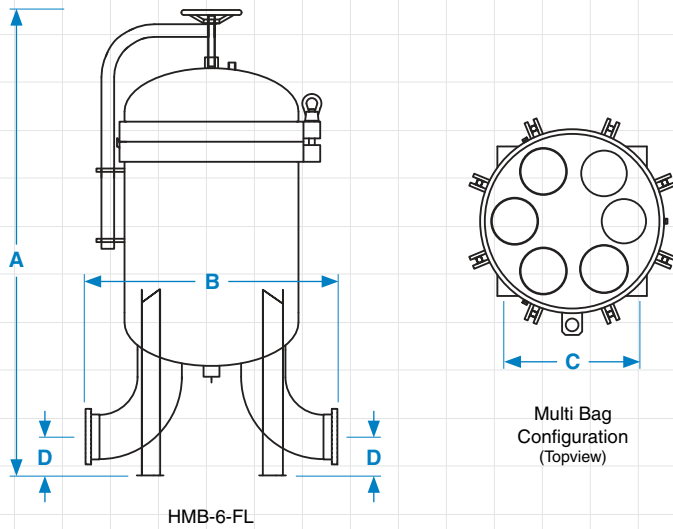

HMB-4-FL

HMB-6-FL

Not Shown: HMB-8-FL and HMB-12-FL

Ordering Information

Filter Model	Max Flow Rate* (GPM)	Max Flow Rate* (LPM)	Max Flow Rate* (M ³ /Hr)	A Filter Height	B Width	C Diameter	D Inlet/Outlet	I/O Size	Drain	Bag Size	Basket Depth	Weight (lbs)
HMB-4-FL	800	3,028	182	65"	30"	13-5/8"	5"	4" FL	2" NPT	#2	30"	620
HMB-6-FL	1,200	4,542	273	67-1/2"	39"	16-1/2"	6"	6" FL	2" NPT	#2	30"	990
HMB-8-FL	1,600	6,057	363	70"	40"	19-5/8"	6"	6" FL	2" NPT	#2	30"	1,320
HMB-12-FL	2,400	9,085	545	75-1/2"	42"	25"	7-1/2"	8" FL	2" NPT	#2	30"	1,740

*Flow rates shown above are for guidelines only. Actual flow rates are based on bag type, micron rating, viscosity, solids content and various other factors. For complete flow and pressure drop information please refer to your bag manufacturer guidelines.

Specifications

- ▶ **Finish** - bead blast
- ▶ **Inlet/Outlet** - flange connections
- ▶ **Construction** - 304 stainless steel; built to ASME design standards
- ▶ **Pressure** - up to 150 PSI (10.3 bar) max
- ▶ **Temperature** - up to 250°F (121°C); filter housing only
- ▶ **Closure** - O-ring housing seal with swing bolt closure

Snap Fit "V" Style Filter Bag

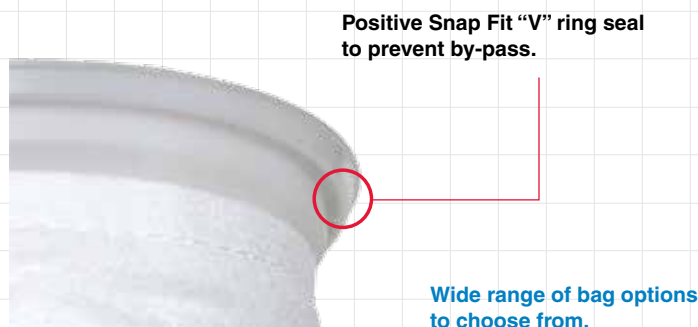

Pressure Drop

Based on 4", 6" and 8" inlet/outlet housings, without bags.

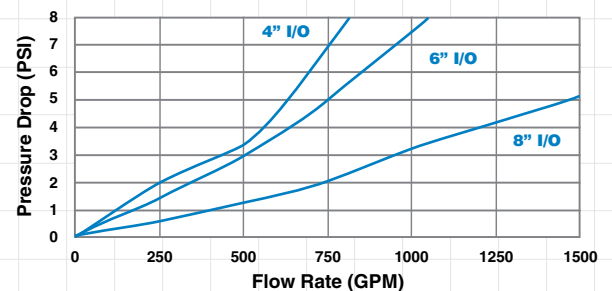

Note: This publication is to be used as a guide. The data within has been obtained from many sources and is considered to be accurate. Harmsco does not assume liability for the accuracy and/or completeness of this data. Changes to the data can be made without notification. Temperature, Pressure, Flow Rates, Differential Pressures, Chemical Combinations and other unknown factors can affect performance in unknown ways. **Limited Warranty:** Harmsco warrants their products to be free of material and workmanship defects. Determination of suitability of Harmsco products for uses and applications contemplated by Buyer shall be the sole responsibility of Buyer. The end user/installer/buyer shall be liable for the product's performance and suitability regarding their specific intended applications. End users should perform their own tests to determine suitability for each application.



HARMSCO® Filtration Products

P.O. Box 14066, North Palm Beach, FL 33408

(561) 848-9628 • Toll-free: (800) 327-3248 • Fax: (561) 845-2474 • E-mail: sales@harmsco.com

www.harmsco.com



Single Bag Housings

Industrial Grade

Designed with Snap Fit “V” Ring Bag Seal to prevent by-pass.

- HSB Series Bag Housings are designed for a variety of industrial filtration applications where clean effluent is critical. Manufactured to ASME design standards for durability and long equipment life.

Features

- ▶ 304 stainless steel construction, standard
- ▶ 150 PSI (10.3 bar) pressure rating
- ▶ 304 stainless steel perforated basket, standard
- ▶ Built to ASME design standards
- ▶ Bead blast finish, standard
- ▶ Designed to accept standard #1 and #2 snap fit “V” ring or steel ring bags
- ▶ Easy-access eye nuts/swing bolts
- ▶ Multiple side and bottom outlet configurations - 2” FNPT
- ▶ Adjustable stainless steel tripod mounting legs

Options:

ASME Code U-stamp
Electropolished
316 stainless steel construction
Flange and BSTP connections available



HSB-1

HSB-2

Applications

- ▶ Paint
- ▶ Process Water Filtration
- ▶ Plating Solutions
- ▶ Coatings
- ▶ Lubricants
- ▶ Solvents
- ▶ Hydraulic Fluids
- ▶ Cutting Fluids
- ▶ Ground Water Remediation
- ▶ Industrial Waste Water Treatment



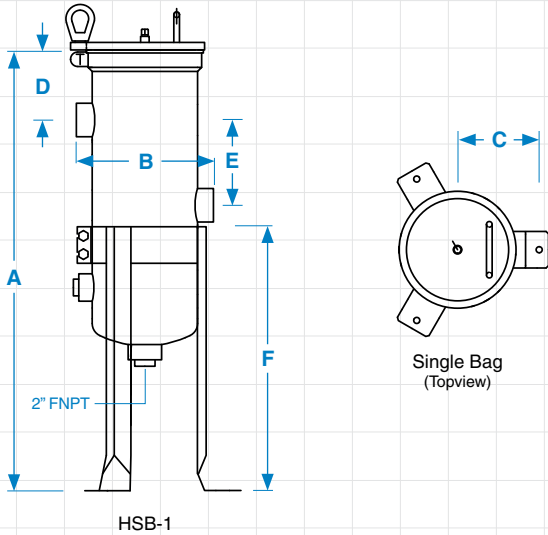

HSB-1

HSB-2

Ordering Information

Filter Model	Max Flow Rate* (GPM)	Max Flow Rate* (LPM)	Max Flow Rate* (M ³ /Hr)	A Filter Height	B Width	C Radius	D Inlet	E Outlet	F Leg Adjust.	I/O Size	I/O Type	Bag Size	Basket Depth	Weight (lbs)
HSB-1	90	341	20	36-1/4"	11-3/4"	6-11/16"	5-3/4"	7"	21-3/4"	2"	FNPT	#1	15"	85
HSB-2	200	757	45	47"***	11-3/4"	6-11/16"	5-3/4"	7"	21-3/4"	2"	FNPT	#2	30"	98

*Flow rates shown above are for guidelines only. Actual flow rates are based on bag type, micron rating, viscosity, solids content and other factors. For complete flow and pressure drop information please refer to your bag manufacturer guidelines.

**Leg adjustment from bottom 2" FNPT to floor, 0 - 11 inches.

Specifications

- ▶ **Finish** - bead blast
- ▶ **Inlet/Outlet** - 2" FNPT
- ▶ **Construction** - 304 stainless steel; built to ASME design standards
- ▶ **O-ring Housing Seal** - Buna (standard)
- ▶ **Pressure** - up to 150 PSI (10.3 bar) max
- ▶ **Temperature** - up to 250°F (121°C) (filter housing only)

Snap Fit "V" Style Filter Bag

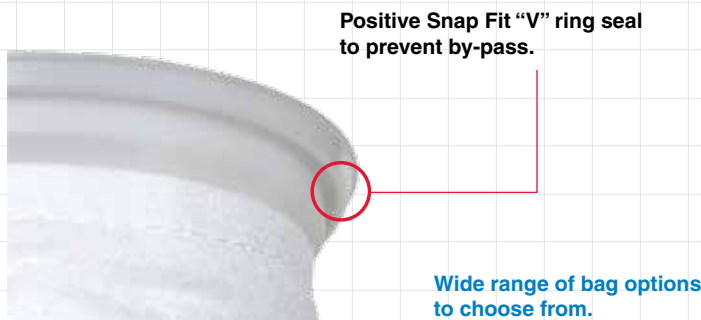

Pressure Drop

Based on 2" inlet/outlet housing, without bag.

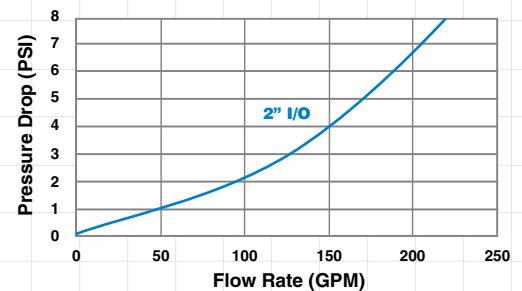

Note: This publication is to be used as a guide. The data within has been obtained from many sources and is considered to be accurate. Harmsco does not assume liability for the accuracy and/or completeness of this data. Changes to the data can be made without notification. Temperature, Pressure, Flow Rates, Differential Pressures, Chemical Combinations and other unknown factors can affect performance in unknown ways. **Limited Warranty:** Harmsco warrants their products to be free of material and workmanship defects. Determination of suitability of Harmsco products for uses and applications contemplated by Buyer shall be the sole responsibility of Buyer. The end user/installer/buyer shall be liable for the product's performance and suitability regarding their specific intended applications. End users should perform their own tests to determine suitability for each application.



HARMSCO® Filtration Products

P.O. Box 14066, North Palm Beach, FL 33408

(561) 848-9628 • Toll-free: (800) 327-3248 • Fax: (561) 845-2474 • E-mail: sales@harmsco.com

www.harmsco.com



Band Clamp Bag Housings

Commercial Grade

Designed with Snap Fit “V” Ring Bag

- BCB Series Bag Housings are designed for a variety of industrial filtration applications where clean effluent is critical. Offered in Extended Area bag sizes to increase contaminant removal and provide longer bag life.

Features

- ▶ 304 stainless steel construction, standard
- ▶ Electropolished finish, standard
- ▶ 150 psi (10.3 bar) pressure rating
- ▶ Flow rates up to 200 gpm
- ▶ All filter housings hydrostatically tested
- ▶ Band clamp closure to simplify maintenance
- ▶ Internal parts are 304 stainless steel
- ▶ Drill in-place legs
- ▶ Patented Extended Area replacement bags available (approx. 30% more surface area vs. Std. bags)
- ▶ 1.5” FNPT or 2” FNPT connections available
- ▶ 316 stainless steel perforated basket, standard

Options:

- 316 stainless steel
- Chemical resistant coating



BCB-1

BCB-2

Applications

- ▶ Paint
- ▶ Process Water
- ▶ Plating Solutions
- ▶ Coatings
- ▶ Industrial Waste Water Treatment
- ▶ Lubricants
- ▶ Solvents
- ▶ Hydraulic Fluids
- ▶ Cutting Fluids
- ▶ Ground Water Remediation



#1

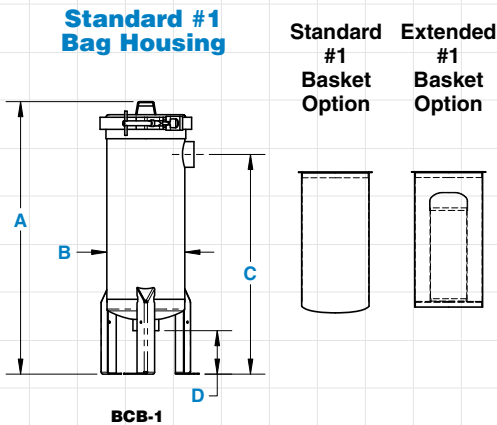

#2

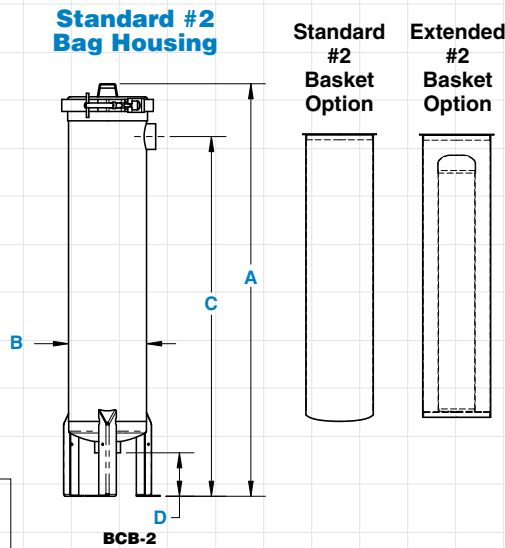

Bag Options



Standard #1
Standard #2
(shown)
Extended #1
Extended #2

Chemical Resistant
Coating Available

Chemical Resistant Coating

Harmsco® Band Clamp Bag Housings are available with a 3M fusion bonded epoxy coating for chemical resistance. The coating is NSF Standard 61 Certified. It is applied to all stainless steel surfaces (inside and out), and is far more resistant than 316L stainless steel. Fusion bonded epoxy coating is ideal for sea water applications and when resistance to aggressive chemicals is required.

Ordering Information

Standard #1 and #2 Bag Housings

Filter Model	Max Flow Rate*(GPM)	Max Flow Rate*(LPM)	Max Flow Rate*(M ³ /Hr)	A Height	B Diameter	C Height	D Height	I/O FNPT	Standard Bag Size
BCB-1-1.5-STD	90	341	20.4	28-1/4"	8"	22-3/4"	4-1/2"	1.5"	1 Std
BCB-1-2-STD	90	341	20.4	28-1/4"	8"	22-3/4"	4-1/2"	2"	1 Std
BCB-2-1.5-STD	200	757	45.4	42-3/4"	8"	37-1/4"	4-1/2"	1.5"	2 Std
BCB-2-2-STD	200	757	45.4	42-3/4"	8"	37-1/4"	4-1/2"	2"	2 Std

Extended #1 and #2 Bag Housings

Filter Model	Max Flow Rate*(GPM)	Max Flow Rate*(LPM)	Max Flow Rate*(M ³ /Hr)	A Height	B Diameter	C Height	D Height	I/O FNPT	Extended Bag Size
BCB-1-1.5-EXT	90	341	20.4	28-1/4"	8"	22-3/4"	4-1/2"	1.5"	1 Ext
BCB-1-2-EXT	90	341	20.4	28-1/4"	8"	22-3/4"	4-1/2"	2"	1 Ext
BCB-2-1.5-EXT	200	757	45.4	42-3/4"	8"	37-1/4"	4-1/2"	1.5"	2 Ext
BCB-2-2-EXT	200	757	45.4	42-3/4"	8"	37-1/4"	4-1/2"	2"	2 Ext

*Flow rates shown above are for guidelines only. Actual flow rates are based on bag type, micron rating, viscosity, solids content and various other factors. For complete flow and pressure drop information please refer to your bag manufacturer guidelines.

Specifications

- ▶ **Finish** - Electropolished
- ▶ **Inlet/Outlet** - 1.5" FNPT or 2" FNPT
- ▶ **Construction** - 304 stainless steel, standard; 316 stainless steel and/or chemical resistant coating, optional
- ▶ **Pressure** - Up to 150 psi (10.3 bar)
- ▶ **Temperature** - up to 250°F(121°C), housing only
- ▶ **Closure** - O-ring Housing Seal - Buna-N

Note: This publication is to be used as a guide. The data within has been obtained from many sources and is considered to be accurate. Harmsco does not assume liability for the accuracy and/or completeness of this data. Changes to the data can be made without notification. Temperature, Pressure, Flow Rates, Differential Pressures, Chemical Combinations and other unknown factors can affect performance in unknown ways. **Limited Warranty:** Harmsco warrants their products to be free of material and workmanship defects. Determination of suitability of Harmsco products for uses and applications contemplated by Buyer shall be the sole responsibility of Buyer. The end user/installer/buyer shall be liable for the product's performance and suitability regarding their specific intended applications. End users should perform their own tests to determine suitability for each application.



HARMSCO® Filtration Products

P.O. Box 14066, North Palm Beach, FL 33408

(561) 848-9628 • Toll-free: (800) 327-3248 • Fax: (561) 845-2474 • E-mail: sales@harmsco.com

www.harmsco.com



Made in USA

© Harmsco, Inc. 16B 10 7/11

Filter Housings – Tab 8

Filtration Systems

Skid Mounted Systems

- ▶ Fabricated steel base
- ▶ Isolation and check valves
- ▶ Automatic timer-controlled filter purge
- ▶ Liquid filled stainless steel pressure gauges
- ▶ Modular suction and discharge header piping
- ▶ NEMA 4X control panel with filter service indicators
- ▶ Differential pressure switches to monitor filter status



Sizing Info:

Custom sizing available

Cartridge Options

**All Cartridge Types Available
depending on application**

GEIGER HARMSCO®

Pre-Engineered Skid Mounted Systems

Commercial/Industrial/Municipal

Make the best filters work better with pre-engineered skid systems by Geiger.

Geiger systems feature Harmsco® Hurricane® Swing Bolt housings for unsurpassed performance.

- Improve reliability while reducing labor and installation costs
- Instant system price quotes
- Quick lead times
- Competitively priced

Features

- ▶ Fabricated steel base
- ▶ Isolation and check valves
- ▶ Automatic timer controlled filter purge
- ▶ Liquid filled stainless steel pressure gauges
- ▶ Modular suction and discharge header piping
- ▶ NEMA 4X control panel with filter service indicators
- ▶ Differential pressure switches to monitor filter status



HUR 1X170 Triplex

Custom Configurations Available

- ▶ Municipal Drinking Water
- ▶ Cooling Tower Filtration
- ▶ Desalination Pre-filtration (coated option)
- ▶ Surface Water Treatment Rule (SWTR) LT2
- ▶ Industrial Waste Water Treatment
- ▶ Reverse Osmosis Pre-filtration
- ▶ Ground Water Remediation
- ▶ Ground Water Under Direct Influence (GUDI)

Standard Configurations

- ▶ **Housings** - HUR 90 HP, 1X170, 3X170
- ▶ **Configurations** - Duplex, Triplex and Quad standard; custom configurations available.

- ▶ **Cartridges** - any Harmsco® cartridges
- ▶ **Material** - stainless steel, PVC and carbon steel header material



HUR 90 HP Duplex



HUR 90 HP Quad



HUR 1X170 Duplex



HUR 1X170 Triplex



HUR 3X170 Duplex

Every Geiger standard skid system quotation comes with detailed product information, complete dimension drawing, and sample specifications.

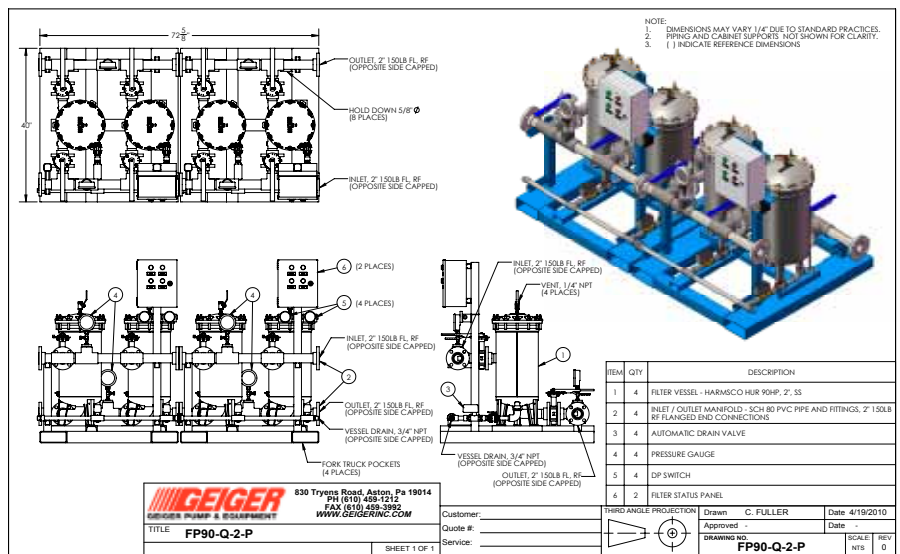

Actual drawing size: 11x17

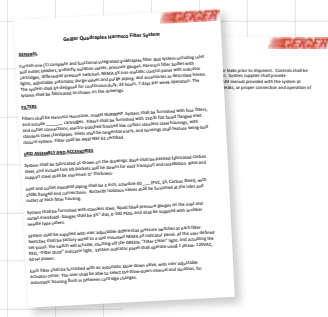

Specifications

Harmsco® Filter Features

- ▶ Patented Up-flow Design
- ▶ Swing Bolt closure system
- ▶ Four sizes for greater utility - one, three, five and eight cartridges
- ▶ The industry's largest selection of cartridge options
- ▶ Electro-polished finish - standard
- ▶ Built to ASME design standards
- ▶ Combination cyclone separator and cartridge filter in a single compact design
- ▶ 304 stainless steel housing and internal components - standard

Note: This publication is to be used as a guide. The data within has been obtained from many sources and is considered to be accurate. Harmsco does not assume liability for the accuracy and/or completeness of this data. Changes to the data can be made without notification. Temperature, Pressure, Flow Rates, Differential Pressures, Chemical Combinations and other unknown factors can affect performance in unknown ways. **Limited Warranty:** Harmsco warrants their products to be free of material and workmanship defects. Determination of suitability of Harmsco products for uses and applications contemplated by Buyer shall be the sole responsibility of Buyer. The end user/installer/buyer shall be liable for the product's performance and suitability regarding their specific intended applications. End users should perform their own tests to determine suitability for each application.

Geiger Pump & Equipment Company

830 Tryens Road, Aston, PA 19014 (800) 969-8383

E-mail: info@geiger-harmsco.com

www.geiger-harmsco.com



Made in USA
© Harmsco, Inc. 13A 08 7/11

Filter Housings – Tab 9

Specialty Housings

WW WaterWarmer™

- ▶ Patented Up-flow design
- ▶ Electropolished 304 stainless steel housing
- ▶ Cartridge cluster removes easily for cartridge cleaning/replacement
- ▶ Three sizes for greater media surface area and thermal output
- ▶ Equipped with Harmsco® Premium 801-20-HT polyester filter cartridges
- ▶ Fail Safe lid closure, rated for 150 psi



Sizing Info:

Call Harmsco factory for sizing info

Cartridge Options

Harmsco® Premium 801-20-HT
polyester filter cartridges

HARMSCO® WaterWarmer™

WW

Heat Exchanger/Cartridge Filter

Improve your machining quality!

The Only Cartridge Filter With A Built-In Heat Exchanger.

- Heat or cool as you filter
No need for separate heat exchanger
Compact design and dual-purpose features save space, piping and installation time
Improves lubrication and cutting performance



Features

- ▶ Patented Up-flow design
- ▶ Electropolished 304 stainless steel housing
- ▶ Cartridge cluster is easily removed for cleaning/replacement
- ▶ Three sizes for greater media surface area and thermal output transmittance
- ▶ Equipped with Harmsco® Premium 801-20-HT Polyester-Plus™ filter cartridges
- ▶ Fail Safe lid closure, rated for 150 psi

Applications

- ▶ Viscous fluid filtration
- ▶ Chilling coolants for sawing/machining
- ▶ Chilled Water Recirculation/Loops
- ▶ Parts washers
- ▶ Plating industry
- ▶ Ultrasonic cleaning

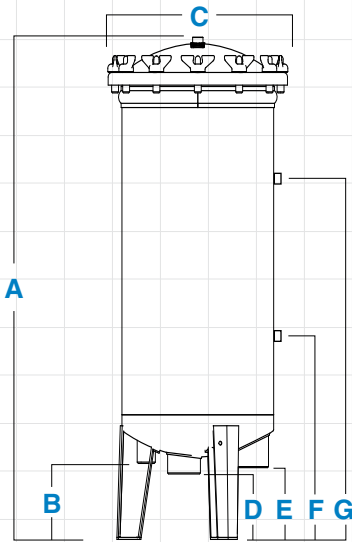

HIF-7-WW



HIF-14-WW



HIF-21-WW

Filter Model	A Filter Height	B Drain	C Diameter	D Outlet	E Inlet	F Heat-Cool Inlet Ht.	G Heat-Cool Outlet Ht.	Pipe Size NPT	Drain Size NPT	Floor Space (in.)	Service Ht.
HIF-7-WW	19-1/4"	4-1/4"	13"	4-1/8"	3-7/8"	8-1/8"	15-1/8"	1-1/2"	1"	15x15	31"
HIF-14-WW	29-3/8"	4-1/4"	13"	4-1/8"	3-7/8"	9-13/16"	25-13/16"	1-1/2"	1"	15x15	51"
HIF-21-WW	39-1/8"	4-1/4"	13"	4-1/8"	3-7/8"	9-13/16"	25-13/16"	1-1/2"	1"	15x15	72"

Specifications

- ▶ Electropolished 304 stainless steel
- ▶ Standpipe - 304 stainless steel
- ▶ Temperature - Up to 200°F (93°C)
- ▶ Pressure - 150 PSI (10 bar) max
- ▶ Lid Closure - Wing nuts, brass
- ▶ Rim Gasket - EPDM (Buna-N, Viton avail.)
- ▶ Inlet/Outlet Connections - standard (1-1/2" NPT plumbing; 1/2" NPT heating/cooling loop)

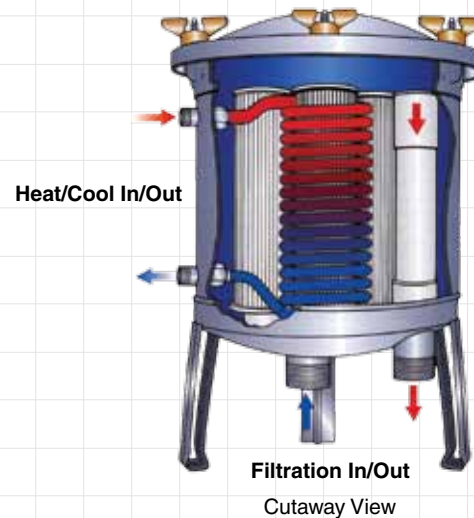

Mechanical Specifications

Model	Filter Area (sq. ft.)	Height (in.)	Floor (in.)	Weight (lbs.)	Coil Area (sq. in.)
HIF-7-WW	42	19-1/2"	13	30	245
HIF-14-WW	84	28	13	43	434
HIF-21-WW	126	37	13	54	434

Operating Specifications For Heat Exchanger*

Model	Thermal Output (BTUs)	Coil Hot/Cold Water Flow (gpm)	Coil Pressure Drop (ft. of head)	Water Flow (gpm)
HIF-7-WW	45,000	3	12.7	22
HIF-14-WW	90,000	6	35.88	45
HIF-21-WW	90,000	6	35.88	45

* Thermal output is based upon a temperature difference of 80°F between incoming hot and incoming cold water at the given flow rate. U.S. Patent #4,455,227

Note: This publication is to be used as a guide. The data within has been obtained from many sources and is considered to be accurate. Harmsco does not assume liability for the accuracy and/or completeness of this data. Changes to the data can be made without notification. Temperature, Pressure, Flow Rates, Differential Pressures, Chemical Combinations and other unknown factors can affect performance in unknown ways. **Limited Warranty:** Harmsco warrants their products to be free of material and workmanship defects. Determination of suitability of Harmsco products for uses and applications contemplated by Buyer shall be the sole responsibility of Buyer. The end user/installer/buyer shall be liable for the product's performance and suitability regarding their specific intended applications. End users should perform their own tests to determine suitability for each application.



HARMSCO® Filtration Products

P.O. Box 14066, North Palm Beach, FL 33408

(561) 848-9628 • Toll-free: (800) 327-3248 • Fax: (561) 845-2474 • E-mail: sales@harmsco.com

www.harmsco.com



Made in USA

© Harmsco, Inc. 15A 11 7/11

Filter Housings – Tab 10

NSF Listed Housings

SB Hurricane® Housings (Tab 1)

- ▶ Combination cyclone separator and cartridge filter in a single design
- ▶ Patented Up-flow design
- ▶ Coated option available
- ▶ Flow rates up to 1,200 GPM
- ▶ Offered in 304 and 316 stainless steel



WB WaterBetter® Housings (Tab 2)

- ▶ Single cartridge design
- ▶ Patented Up-flow design
- ▶ Offered in 304 and 316 stainless steel
- ▶ Coated option available
- ▶ Flow rates up to 150 GPM



HP Hurricane® Housings (Tab 1)

- ▶ Combination cyclone separator and cartridge filter in a single design
- ▶ Patented Up-flow design
- ▶ Coated option available
- ▶ Flow rates up to 150 GPM
- ▶ Offered in 304 and 316 stainless steel



HIF Filter Housings (Tab 4)

- ▶ Patented Up-flow design
- ▶ Offered in 304 and 316 stainless steel
- ▶ Coated option available
- ▶ Flow rates up to 800 GPM



Note: This publication is to be used as a guide. The data within has been obtained from many sources and is considered to be accurate. Harmsco does not assume liability for the accuracy and/or completeness of this data. Changes to the data can be made without notification. Temperature, Pressure, Flow Rates, Differential Pressures, Chemical Combinations and other unknown factors can affect performance in unknown ways. **Limited Warranty:** Harmsco warrants their products to be free of material and workmanship defects. Determination of suitability of Harmsco products for uses and applications contemplated by Buyer shall be the sole responsibility of Buyer. The end user/installer/buyer shall be liable for the product's performance and suitability regarding their specific intended applications. End users should perform their own tests to determine suitability for each application.

Filter Cartridge Selection Guide

Tab 21 Hurricane® Cartridges

- ▶ High flow, high surface area
- ▶ Low initial pressure drop provides longer filter life
- ▶ High Temperature cartridges available
- ▶ Lowest cost per filtered gallon based on surface area

 NSF-61 Listed cartridges available



Tab 22 Premium & WaterBetter® Cartridges

- ▶ 2-1/2" and 2-3/4" O.D. pleated cartridges designed for Harmsco® HIF, Band Clamp and competitive filter housings
- ▶ Available in 9-3/4", 10", 20", 30" and 40" cartridge lengths
- ▶ All cartridges shrink wrapped

 NSF-61 Listed



Tab 23 701 Series Cartridges

- ▶ 2-1/2" O.D. pleated cartridges designed for Harmsco® and competitive filter housings
- ▶ 9-3/4", 10", 20", 30" and 40" lengths; Polyester, Harmsco-Free™ and Poly-Pleat™ media
- ▶ All cartridges shrink wrapped

 NSF-61 Listed



Tab 24 Calypso Blue™ Cartridges

- ▶ 4-1/2" O.D. pleated cartridges designed for Harmsco® HIF, Band Clamp and single cartridge housings
- ▶ Premium Series offers up to 12 sq.ft. of media per 9-3/4" length; WaterBetter® Series 9.5 sq. ft.
- ▶ All cartridges shrink wrapped

 NSF-61 Listed



Tab 25 SureSafe™ Cartridges

- ▶ Antimicrobial cartridge media prohibits growth of bacteria and mold on filter cartridge
- ▶ Offered in 20 and 50 micron ratings and a wide range of cartridge sizes
- ▶ Agion Silver Zeolite is FDA tested and registered with the EPA



Tab 26 Poly-Pleat™ Cartridges

- ▶ Pleated one micron absolute cartridges for safe, cyst-free drinking water
- ▶ Available in a wide range of cartridge sizes

 NSF-61 Listed



Tab 27 Carbon Cartridges

- ▶ Hurricane®, HAC and WaterBetter® Carbon cartridges for high chlorine, taste, odor, lead, THM and organic chemical removal
- ▶ Available in a wide range of cartridge sizes, including Hurricane® 170 Series

 NSF-42 Listed - Component



Tab 28 All Poly/High Purity Cartridges

- ▶ Available in: Polypropylene - PP; Polyethersulfone - PES Membrane; Microfiberglass - FG; Nylon 6,6 - NY and Plus + Nylon 6,6 - NYP; Teflon - TF Membrane and Polysulfone (PS)
- ▶ Available in DOE, 222 w/Fin, 222 w/Flat Cap, 226 w/Flat Cap, 226 w/Fin, 213 Internal O-Ring
- ▶ Available in Hurricane® sizes 40, 90, 170 and 0.2, 0.45, 1, 5, 10, 20, 50 micron ratings.



Tab 29 High Temperature Cartridges

- ▶ Pleated polyester or cellulose phenolic media
- ▶ Two temperature ratings to choose from: 200°F (93°C) and 250°F (121°C)
- ▶ Designed for Hurricane® and WaterBetter® housings



Tab 30 Liquid Filter Bags

- ▶ "V" Seal Ring Bags available to prevent by-pass
- ▶ Polypropylene and Polyester options available
- ▶ Broad chemical compatibility
- ▶ Industry #1, #2 and EXT extended bag sizes available



Tab 31 NSF Listed Cartridges



Note: This publication is to be used as a guide. The data within has been obtained from many sources and is considered to be accurate. Harmsco does not assume liability for the accuracy and/or completeness of this data. Changes to the data can be made without notification. Temperature, Pressure, Flow Rates, Differential Pressures, Chemical Combinations and other unknown factors can affect performance in unknown ways. **Limited Warranty:** Harmsco warrants their products to be free of material and workmanship defects. Determination of suitability of Harmsco products for uses and applications contemplated by Buyer shall be the sole responsibility of Buyer. The end user/installer/buyer shall be liable for the product's performance and suitability regarding their specific intended applications. End users should perform their own tests to determine suitability for each application.

HARMSCO®

Premium Hurricane® Polyester Cartridges

Maximum Surface Area

Designed for Hurricane® and WaterBetter® Filter Housings

High Flow Performance

Lower Operation Cost with Hurricane® Cartridges

- High flow capability
- Lower overall operating cost
- Reduced waste disposal
- Longer filter runs for fewer change-outs
- Increased contaminant removal
- Operator friendly



Certified to
ANSI-NSF 61



Premium Hurricane®
Polyester Cartridges

Features

- ▶ Fewer cartridges for fewer change-outs and lower maintenance cost
- ▶ Pleated Polyester-Plus™ filter media provides higher flow rates and lower initial pressure drop
- ▶ Pleated surface area provides higher loading capacity for longer filter life and increased particle removal
- ▶ End cap, center tube and media are thermally bonded as one integral component for added strength
- ▶ Offered in three sizes (40, 90 and 170) and eight micron ratings (0.35, 1, 5, 10, 20, 50, 100 and 150) to meet all your high flow requirements

Applications

- ▶ Reverse Osmosis Pre-filtration
- ▶ Municipal Drinking Water Filtration
- ▶ Commercial/Residential Drinking Water Filtration
- ▶ Desalination Pre-filtration
- ▶ Industrial Water Filtration
- ▶ Cooling Tower Filtration
- ▶ Chill Water Loop Filtration
- ▶ Food & Beverage Filtration
- ▶ Marine/Aquatic Filtration
- ▶ Industrial Coolant Filtration



HARMSCO® Filtration Products



Made in USA

Premium Hurricane® Polyester Cartridges

Specifications

- ▶ **Micron Ratings:** Nominal micron ratings of 0.35, 1, 5, 10, 20, 50, 100, 150
- ▶ **Filter Media:** nominal pleated Polyester-Plus™
- ▶ **End Caps:** Pliable PVC with sealing surface built-in
- ▶ **Center Tubes:** ABS or PVC
- ▶ **Temperature:** 140°F (60°C) temperature limit*
* Temperature limits vary and depend on pressure and time under load.

Cleanable/Reusable in most filtration applications and micron ratings.



Certified to ANSI-NSF 61

Cartridge Selection/Sizing Guide

7-3/4" O.D. For Harmsco® Hurricane® and WaterBetter® Single-cartridge Filter Housings

Cartridge Length	Product Code	Nominal Micron Rating	Media (sq ft)	Recommended Flow Rate* (GPM)	Max Flow Rate* (GPM)	Max Flow Rate* (LPM)	Max Flow Rate* (M ³ /HR)	No./ Carton	Carton Size
Premium Hurricane® Polyester Cartridges - rated up to 140°F (60°C).									
9-5/8"	HC/40-0.35	0.35	40	35	50	189	12	1	9x9x11
	HC/40-1	1	40	35	50	189	12	1	9x9x11
	HC/40-5	5	40	35	50	189	12	1	9x9x11
	HC/40-10	10	40	35	50	189	12	1	9x9x11
	HC/40-20	20	40	35	50	189	12	1	9x9x11
	HC/40-50	50	40	35	50	189	12	1	9x9x11
	HC/40-100	100	40	35	50	189	12	1	9x9x11
19-1/2"	HC/40-150	150	40	35	50	189	12	1	9x9x11
	HC/90-0.35	0.35	90	70	100	378	24	1	9x9x21
	HC/90-1	1	90	70	100	378	24	1	9x9x21
	HC/90-5	5	90	70	100	378	24	1	9x9x21
	HC/90-10	10	90	70	100	378	24	1	9x9x21
	HC/90-20	20	90	70	100	378	24	1	9x9x21
	HC/90-50	50	90	70	100	378	24	1	9x9x21
30-3/4"	HC/90-100	100	90	70	100	378	24	1	9x9x21
	HC/90-150	150	90	70	100	378	24	1	9x9x21
	HC/170-0.35	0.35	170	105	150	568	36	1	9x9x32
	HC/170-1	1	170	105	150	568	36	1	9x9x32
	HC/170-5	5	170	105	150	568	36	1	9x9x32
	HC/170-10	10	170	105	150	568	36	1	9x9x32
	HC/170-20	20	170	105	150	568	36	1	9x9x32
HC/170-50	50	170	105	150	568	36	1	9x9x32	
HC/170-100	100	170	105	150	568	36	1	9x9x32	
HC/170-150	150	170	105	150	568	36	1	9x9x32	

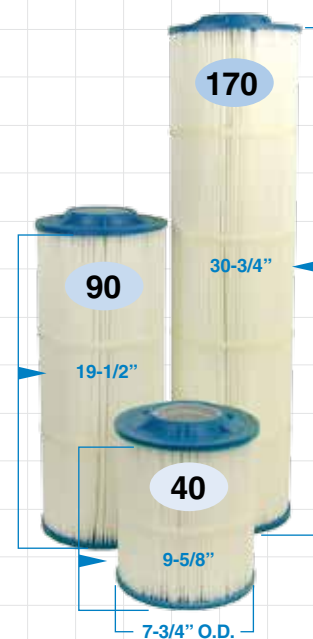

Premium Hurricane® Polyester Cartridges

Length and O.D.

*Harmsco® recommends operation at 70% of maximum flow rate for optimum performance.

Pressure Drop

Pressure drop shown at right is for filter housing and 20 micron filter cartridge in clean water.

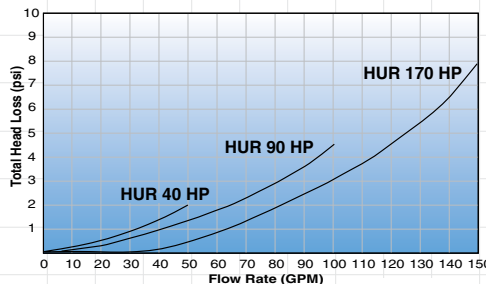

Note: This publication is to be used as a guide. The data within has been obtained from many sources and is considered to be accurate. Harmsco does not assume liability for the accuracy and/or completeness of this data. Changes to the data can be made without notification. Temperature, Pressure, Flow Rates, Differential Pressures, Chemical Combinations and other unknown factors can affect performance in unknown ways. **Limited Warranty:** Harmsco warrants their products to be free of material and workmanship defects. Determination of suitability of Harmsco products for uses and applications contemplated by Buyer shall be the sole responsibility of Buyer. The end user/installer/buyer shall be liable for the product's performance and suitability regarding their specific intended applications. End users should perform their own tests to determine suitability for each application.



HARMSCO® Filtration Products

P.O. Box 14066, North Palm Beach, FL 33408

(561) 848-9628 • Toll-free: (800) 327-3248 • Fax: (561) 845-2474 • E-mail: sales@harmsco.com

www.harmsco.com



Made in USA

© Harmsco, Inc. 27B 07 7/11

HARMSCO®

Premium Hurricane® Harmsco-Free Cartridges

Cellulose Free Media

Designed for Hurricane® and WaterBetter® Filter Housings

High Flow Performance

Lower Operation Cost with Hurricane® Cartridges

- High flow capability
- Lower overall operating cost
- Reduced waste disposal
- Longer filter runs for fewer change-outs
- Increased contaminant removal
- Operator friendly



Certified to
ANSI-NSF 61



Premium Hurricane®
Harmsco-Free Cartridges

Features

- ▶ Fewer cartridges for fewer change-outs and lower maintenance cost
- ▶ Pleated synthetic composite filter media provides higher flow rates and lower initial pressure drop
- ▶ Pleated surface area provides higher loading capacity for longer filter life and increased particle removal
- ▶ End cap, center tube and media are thermally bonded as one integral component for added strength
- ▶ Offered in three sizes (40, 90 and 170) and three micron ratings (1, 5, 20) to meet all your high flow requirements

Applications

- ▶ Reverse Osmosis Pre-filtration
- ▶ Municipal Drinking Water Filtration
- ▶ Commercial/Residential Drinking Water Filtration
- ▶ Desalination Pre-filtration
- ▶ Industrial Water Filtration
- ▶ Cooling Tower Filtration
- ▶ Chill Water Loop Filtration
- ▶ Food & Beverage Filtration
- ▶ Marine/Aquatic Filtration
- ▶ Water Bottlers



HARMSCO® Filtration Products



Made in USA

Premium Hurricane® Harmsco-Free Cartridges

Specifications

- ▶ **Micron Ratings:** Nominal micron ratings of 1, 5 and 20
- ▶ **Center Tubes:** ABS or PVC
- ▶ **End Caps:** Pliable PVC with sealing surface built-in
- ▶ **Filter Media:** 100% cellulose-free synthetic composite media
- ▶ **Temperature:** 140°F (60°C) temperature limit*
* Temperature limits vary and depend on pressure and time under load.

Cleanable/Reusable in most filtration applications and micron ratings.



Certified to ANSI-NSF 61

Cartridge Selection/Sizing Guide

7-3/4" O.D. For Harmsco® Hurricane® and WaterBetter® Single-cartridge Filter Housings

Cartridge Length	Product Code	Nominal Micron Rating	Media (sq ft)	Recommended Flow Rate* (GPM)	Max Flow Rate* (GPM)	Max Flow Rate* (LPM)	Max Flow Rate* (M ³ /HR)	No./Carton	Carton Size
	Harmsco-Free - 100% cellulose-free synthetic composite media.								
9-5/8"	HC/40-1W-HF	1	30	35	50	189	12	1	9x9x11
	HC/40-5W-HF	5	30	35	50	189	12	1	9x9x11
	HC/40-20W-HF	20	30	35	50	189	12	1	9x9x11
19-1/2"	HC/90-1W-HF	1	70	70	100	378	24	1	9x9x21
	HC/90-5W-HF	5	70	70	100	378	24	1	9x9x21
	HC/90-20W-HF	20	70	70	100	378	24	1	9x9x21
30-3/4"	HC/170-1W-HF	1	120	105	150	568	36	1	9x9x32
	HC/170-5W-HF	5	120	105	150	568	36	1	9x9x32
	HC/170-20W-HF	20	120	105	150	568	36	1	9x9x32

*Harmsco® recommends operation at 70% of maximum flow rate for optimum performance.

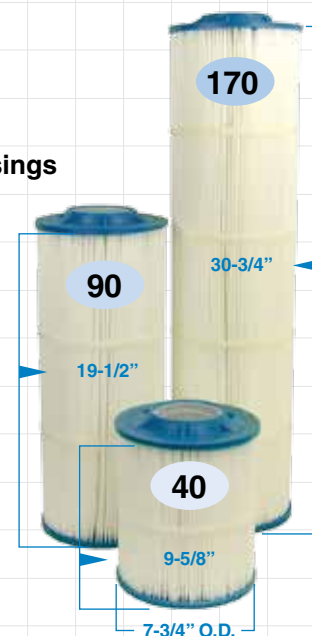

Premium Hurricane® Harmsco-Free Cartridges
Length and O.D.

Pressure Drop

Pressure drop shown at right is for filter housing and 20 micron filter cartridge in clean water.

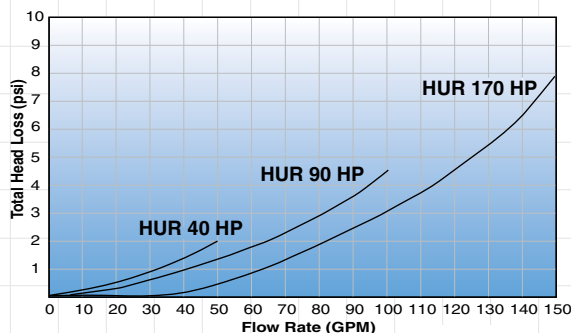

Note: This publication is to be used as a guide. The data within has been obtained from many sources and is considered to be accurate. Harmsco does not assume liability for the accuracy and/or completeness of this data. Changes to the data can be made without notification. Temperature, Pressure, Flow Rates, Differential Pressures, Chemical Combinations and other unknown factors can affect performance in unknown ways. **Limited Warranty:** Harmsco warrants their products to be free of material and workmanship defects. Determination of suitability of Harmsco products for uses and applications contemplated by Buyer shall be the sole responsibility of Buyer. The end user/installer/buyer shall be liable for the product's performance and suitability regarding their specific intended applications. End users should perform their own tests to determine suitability for each application.



HARMSCO® Filtration Products

P.O. Box 14066, North Palm Beach, FL 33408

(561) 848-9628 • Toll-free: (800) 327-3248 • Fax: (561) 845-2474 • E-mail: sales@harmsco.com

www.harmsco.com



Made in USA

© Harmsco, Inc. 38C 07 7/11

HARMSCO®

Premium Hurricane® High-Temp Cartridges

Industrial Grade

Designed for Hurricane® and WaterBetter® Housings

High temperature pleated cartridges for high capacity filtration. Two types of filter media for flexibility: Polyester-Plus™ and Cellulose Phenolic.

- High flow capability
- Two types of pleated media for flexibility
- Lower overall operating cost
- Longer filter runs for fewer change outs
- Increased contaminant removal
- Two temperature ratings to choose from: 200°F (93°C) and 250°F (121°C)

Features

- ▶ Fewer cartridges for fewer change outs and lower maintenance cost
- ▶ Pleated filter media provides higher flow rates and lower initial pressure drop
- ▶ Pleated surface area provides higher loading capacity for longer filter life and increased particle removal
- ▶ Aqueous and oil based fluid applications
- ▶ High surface area (40, 90 and 170 sq. ft.) in a single cartridge design



Cellulose Phenolic
90 and 170

Polyester-Plus™
40, 90 and 170

Applications

- ▶ Hot Water Loops
- ▶ Boiler Make-up Water
- ▶ Petrochemical
- ▶ Lubricating Oil
- ▶ Cutting Fluids
- ▶ Solvents
- ▶ Distillate Fuel
- ▶ Fuel Oil
- ▶ Hydraulic Fluids
- ▶ Bio Fuels



HARMSCO® Filtration Products



Made in USA

Premium Hurricane® High-Temp Cartridges

Specifications

- ▶ **Filter media:** polyester or cellulose phenolic
- ▶ **End Caps:** injection molded (Suffix HT) or powder coated metal (Suffix HTM)
- ▶ **Temperature:** up to 200°F (93°C) w/suffix HT; up to 250°F (121°C) w/suffix HTM
- ▶ **Center Core:** powder coated perforated metal
- ▶ **pH:** 6.5 to 9.5
- ▶ **Change Out:** 25 PSI ΔP (1.7 bar)
- ▶ **O-Rings & Sealing Grommet:** Buna N standard, optional Viton available

Cartridge Selection/Sizing Guide

7-3/4" O.D. Temperature ratings based on pressure and time under load.

Cartridge Length

Product Code	Nominal Micron Rating	Media (sq ft)	Recommended Flow Rate* (GPM)	Length (in)	No./Carton
Polyester-Plus™ - rated up to 200°F (93°C)					
HC/40-20HT	20	40	35	9-5/8	1
HC/40-50HT	50	40	35	9-5/8	1
HC/90-5HT	5	90	70	19-1/2	1
HC/90-10HT	10	90	70	19-1/2	1
HC/90-20HT	20	90	70	19-1/2	1
HC/90-50HT	50	90	70	19-1/2	1
HC/170-5HT	5	170	105	30-3/4	1
HC/170-10HT	10	170	105	30-3/4	1
HC/170-20HT	20	170	105	30-3/4	1
HC/170-50HT	50	170	105	30-3/4	1

Polyester-Plus™ - rated up to 250°F (121°C)

HC/40-20HTM	20	40	35	9-5/8	1
HC/40-50HTM	50	40	35	9-5/8	1
HC/90-5HTM	5	90	70	19-1/2	1
HC/90-10HTM	10	90	70	19-1/2	1
HC/90-20HTM	20	90	70	19-1/2	1
HC/90-50HTM	50	90	70	19-1/2	1
HC/170-5HTM	5	170	105	30-3/4	1
HC/170-10HTM	10	170	105	30-3/4	1
HC/170-20HTM	20	170	105	30-3/4	1
HC/170-50HTM	50	170	105	30-3/4	1

Cellulose Phenolic - rated up to 200°F (93°C)

HC/90-5CPHT	5	90	70	19-1/2	1
HC/170-5CPHT	5	170	105	30-3/4	1

Cellulose Phenolic - rated up to 250°F (121°C)

HC/90-5CPHTM	5	90	70	19-1/2	1
HC/170-5CPHTM	5	170	105	30-3/4	1

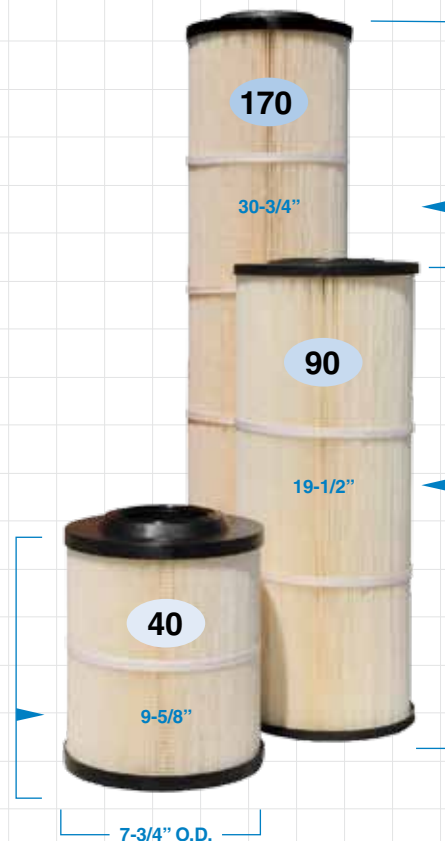

Hurricane® Cartridges
Length and O.D.

Pressure Drop

Pressure drop shown at right is for filter housing and 20 micron filter cartridge in clean water.

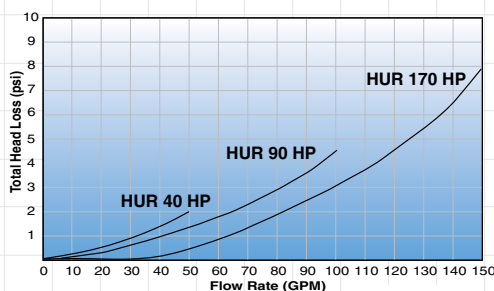

Note: This publication is to be used as a guide. The data within has been obtained from many sources and is considered to be accurate. Harmsco does not assume liability for the accuracy and/or completeness of this data. Changes to the data can be made without notification. Temperature, Pressure, Flow Rates, Differential Pressures, Chemical Combinations and other unknown factors can affect performance in unknown ways. **Limited Warranty:** Harmsco warrants their products to be free of material and workmanship defects. Determination of suitability of Harmsco products for uses and applications contemplated by Buyer shall be the sole responsibility of Buyer. The end user/installer/buyer shall be liable for the product's performance and suitability regarding their specific intended applications. End users should perform their own tests to determine suitability for each application.



HARMSCO® Filtration Products

P.O. Box 14066, North Palm Beach, FL 33408

(561) 848-9628 • Toll-free: (800) 327-3248 • Fax: (561) 845-2474 • E-mail: sales@harmsco.com

www.harmsco.com



Made in USA

© Harmsco, Inc. 26B 11 7/11

HARMSCO®

Premium Hurricane® Carbon Cartridges

DBP Tested

Designed for Hurricane® and WaterBetter® filter housings.

Activated Carbon cartridges for Hurricane® and WaterBetter® filter housings - featuring 5 micron nominal pre-filtration. The industry's largest carbon block cartridge.

- High chlorine removal
- High THMs removal
- Longer filter runs for fewer change-outs
- Lower initial pressure drops
- Reduced maintenance down time and cost
- Increased contaminant removal
- taste, odors, DBPs
- Easy to install and clean

Features

- ▶ High performance extruded activated carbon block technology
- ▶ Integrated 5 micron pleated pre-filter for extended life
- ▶ Three sizes for greater media surface area
- ▶ Low initial pressure drop compared to granular activated carbon (no channeling)
- ▶ Patented Dual Durometer end caps to ensure better sealing
- ▶ Engineered media for superior performance
- ▶ Cleanable and reusable in most applications
- ▶ DBP Tested



Cut-away view



HC/40-AC-5

HC/90-AC-5

Applications

- ▶ Commercial/Residential Drinking Water Filtration
- ▶ Reverse Osmosis Pre-filtration
- ▶ Water Bottling Filtration
- ▶ Point of entry for the dwelling
- ▶ Industrial Waste Water Treatment
- ▶ Environmental Filtration
- ▶ Industrial/Commercial Process Water



HARMSCO® Filtration Products



Made in USA

Premium Hurricane® Carbon Cartridges

Specifications

- ▶ **Carbon:** high performance extruded activated carbon block
- ▶ **Outer layer:** 5 micron nominal pleated Polyester-Plus™ media
- ▶ **Center tubes:** PVC, rigid and perforated
- ▶ **End caps:** Plastisol (pliable PVC) Dual Durometer
- ▶ **Directional flow:** radial (outside to in) for low pressure drop
- ▶ **Temperature:** rated to 125°F (52°C)

Cartridge Selection/Sizing Guide

40 90 170

7-3/4" O.D. Hurricane® Carbon Cartridges

Cartridge Length

9-5/8"
19-1/2"
30-3/4"

Product Code	Nominal Micron Rating	Media (sq.ft.)	Recommended Flow Rate (GPM)	Min. Carbon Content** (lbs)	Capacity**	Chlorine Reduction*	THMs Reduction
HC/40-AC-5	5	25	5	3	90,000 gals	90-95% at 5 gpm	95-98% at 5 gpm
HC/90-AC-5	5	55	10	6.25	180,000 gals	90-95% at 10 gpm	95-98% at 10 gpm
HC/170-AC-5	5	90	15	10	270,000 gals	90-95% at 15 gpm	95-98% at 15 gpm

Not recommended for drinking water applications where water is not micro-biologically safe.

*Results may vary and are based on flow and other factors. **Approximate.

Note: As with any fluid application involving carbon media, "slower is better." As a result, Harmsco, Inc. recommends limiting flow rates to allow for effective contact time. The above listed data, based on 2 PPM chlorine feed, indicates potential chlorine reduction for a volume of chlorinated water at given flow rates.



Performance of carbon block core validated by the U.S. EPA

Each cartridge individually shrink wrapped and boxed for protection.

High carbon content for extended performance. Outer layer of pleated 5 micron Polyester-Plus™ filter media to protect the carbon by removing sediment and extend filter life.

Pressure Drop

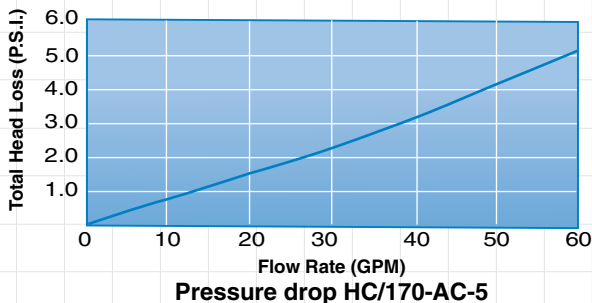

Dual Durometer End Cap

Plastisol

Carbon

5 Micron Media



Cut-away view

Note: This publication is to be used as a guide. The data within has been obtained from many sources and is considered to be accurate. Harmsco does not assume liability for the accuracy and/or completeness of this data. Changes to the data can be made without notification. Temperature, Pressure, Flow Rates, Differential Pressures, Chemical Combinations and other unknown factors can affect performance in unknown ways. **Limited Warranty:** Harmsco warrants their products to be free of material and workmanship defects. Determination of suitability of Harmsco products for uses and applications contemplated by Buyer shall be the sole responsibility of Buyer. The end user/installer/buyer shall be liable for the product's performance and suitability regarding their specific intended applications. End users should perform their own tests to determine suitability for each application.



HARMSCO® Filtration Products

P.O. Box 14066, North Palm Beach, FL 33408

(561) 848-9628 • Toll-free: (800) 327-3248 • Fax: (561) 845-2474 • E-mail: sales@harmsco.com

www.harmsco.com



Made in USA

© Harmsco, Inc. 33A 21 7/11

HARMSCO®

Premium Hurricane® All-Poly Cartridges

Industrial Grade

Designed for Hurricane® and WaterBetter® Filter Housings

These high flow polypropylene cartridges are designed for most applications where absolute rated pleated filtration is needed. Designed to hold up to 75 sq.ft. of filtration media, our All-Poly high flow cartridge is a great value. These cartridges are constructed with 100% polypropylene materials. Efficiency ratings to 99.98% (Beta 5000).

- High flow capability
- Lower overall operating cost
- Reduces waste disposal
- Longer filter runs for fewer change outs
- Increased contaminate removal

Features

- ▶ Fewer cartridges for fewer change outs and lower maintenance cost
- ▶ Pleated polypropylene filter media provides higher flow rates and lower initial pressure drop
- ▶ Pleated surface area provides higher loading capacity for longer filter life and increased particle removal
- ▶ Double o-ring end cap, center tube and media are thermally bonded as one integral component for added strength
- ▶ Offered in three sizes (40, 90, 170) and seven micron ratings (0.2, 0.45, 1, 5, 10, 20, 50) to meet high flow requirements



Premium Hurricane®
All-Poly Cartridges

Applications

- ▶ Acids and bases
- ▶ Glycol
- ▶ Pre-filtration for DI resins
- ▶ Pre-filtration UF membranes
- ▶ Photochemical plating solutions
- ▶ Organic solvents
- ▶ Machine coolants
- ▶ Food & Beverage
- ▶ Bottled water
- ▶ Aqueous solutions
- ▶ Magnetic tape coatings
- ▶ Pre-filtration for RO
- ▶ Cosmetics
- ▶ Inks



HARMSCO® Filtration Products



Made in USA

Premium Hurricane® All-Poly Cartridges

Specifications

- ▶ **Filter media:** Polypropylene
- ▶ **Support Media:** Polypropylene
- ▶ **Outer Support Media:** Polypropylene
- ▶ **Temperature:** 180°F (82°C)
- ▶ **Sanitization/Sterilization:**
 - Filtered hot water - 194°F (90°C)
 - Chemical Sanitization - industry standard concentrations of hydrogen peroxide, peracetic acid, sodium hypochlorite and other selected chemicals
- ▶ **End Caps:** Polypropylene
- ▶ **Center Core:** Polypropylene
- ▶ **O-Rings:** Silicone (standard), Buna, Viton
- ▶ **Change Out:** 35 PSI ΔP (2.4 bar)

FDA Listed Materials:

Manufactured from materials which are listed for food contact applications in Title 21 of the U.S. Code of Federal Regulations.

Cartridge Selection/Sizing Guide

7-3/4" O.D. - 100% polypropylene materials

Cartridge Length	Product Code	Absolute Micron Rating	Media (sq ft)	Recommended Flow Rate* (GPM)	Maximum Flow Rate* (GPM)	No./Carton	
9-5/8"	All-Poly - for high flow applications requiring absolute rated filtration.						
	HC-PP-40-0.2	0.2	25	17	19	1	
	HC-PP-40-0.45	0.45	25	17	19	1	
	HC-PP-40-1	1	25	17	19	1	
	HC-PP-40-5	5	25	17	19	1	
	HC-PP-40-10	10	25	17	19	1	
	HC-PP-40-20	20	25	17	19	1	
	HC-PP-40-50	50	25	17	19	1	
	19-1/2"	HC-PP-90-0.2	0.2	50	35	38	1
		HC-PP-90-0.45	0.45	50	35	38	1
HC-PP-90-1		1	50	35	38	1	
HC-PP-90-5		5	50	35	38	1	
HC-PP-90-10		10	50	35	38	1	
HC-PP-90-20		20	50	35	38	1	
HC-PP-90-50		50	50	35	38	1	
30-3/4"		HC-PP-170-0.2	0.2	75	40	76	1
		HC-PP-170-0.45	0.45	75	40-65	76	1
		HC-PP-170-1	1	75	65-100	76	1
	HC-PP-170-5	5	75	65-100	76	1	
	HC-PP-170-10	10	75	65-100	76	1	
	HC-PP-170-20	20	75	65-100	76	1	
	HC-PP-170-50	50	75	65-100	76	1	

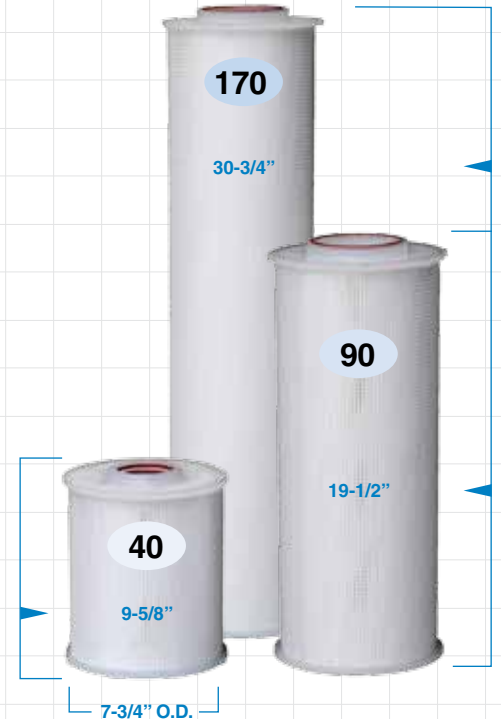

Hurricane® All-Poly Cartridges
Length and O.D.

Pressure Drop

Pressure Drop vs. Flow Rate

The total head loss data shown at right indicates pressure drop with Hurricane® 170 filter housing and Hurricane® All-Poly 170 filter cartridges in 5 different micron ratings in clean water.

Hurricane® All-Poly 170 Cartridges

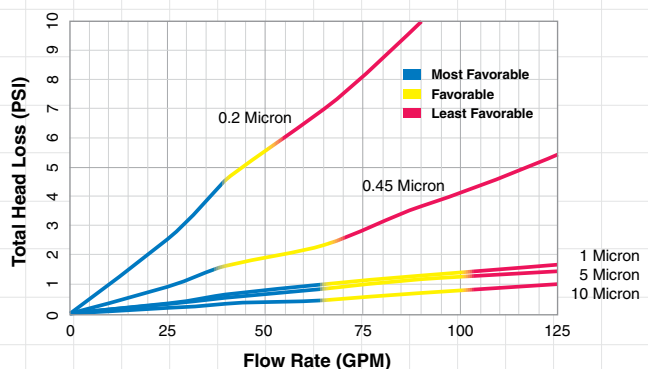

Note: This publication is to be used as a guide. The data within has been obtained from many sources and is considered to be accurate. Harmsco does not assume liability for the accuracy and/or completeness of this data. Changes to the data can be made without notification. Temperature, Pressure, Flow Rates, Differential Pressures, Chemical Combinations and other unknown factors can affect performance in unknown ways. **Limited Warranty:** Harmsco warrants their products to be free of material and workmanship defects. Determination of suitability of Harmsco products for uses and applications contemplated by Buyer shall be the sole responsibility of Buyer. The end user/installer/buyer shall be liable for the product's performance and suitability regarding their specific intended applications. End users should perform their own tests to determine suitability for each application.



HARMSCO® Filtration Products

P.O. Box 14066, North Palm Beach, FL 33408

(561) 848-9628 • Toll-free: (800) 327-3248 • Fax: (561) 845-2474 • E-mail: sales@harmsco.com

www.harmsco.com



Made in USA

© Harmsco, Inc. 27A 16 7/11

HARMSCO®

Premium SureSafe™ Cartridges

Antimicrobial Media

Designed for HIF, Band Clamp, Hurricane®, WaterBetter® Calypso Blue™ and Single Filter Housings.

Harmsco® SureSafe™ cartridges are fabricated with the latest in Silver Zeolite technology and provide antimicrobial protection on the cartridge, outlasting the competition.

- Lower overall operating cost
- Inhibits growth of algae & bacteria on the media
- Longer filter runs for fewer change-outs
- Lower pressure drops
- Reduced maintenance down time and cost
- Increased contaminant removal
- Easy to install, remove, clean and replace

Agion Silver Zeolite is
FDA Tested and EPA Registered

EPA Registration No. 71227-1-72854
EPA Establishment No. 72854-MA-001



Features

- ▶ Pleated design for more surface area
- ▶ Utilizes Agion Silver Zeolite fibers
- ▶ Agion Silver Zeolite is effective against more than 650 strains of bacteria, fungi and mold
- ▶ Agion Silver Zeolite is FDA tested and registered with the EPA
- ▶ Engineered media for superior performance
- ▶ Cleanable and reusable in most applications and micron ratings

Applications

- ▶ Pre-Reverse Osmosis Filtration
- ▶ Boiler Make-up Water Filtration
- ▶ Chill Water Loop Filtration
- ▶ Cooling Tower Filtration
- ▶ Surface Water Filtration
- ▶ Well Water
- ▶ Salt Water/Desalination Filtration
- ▶ Industrial Waste Water Filtration
- ▶ Pre-filter for Carbon Filters
- ▶ Marine/Aquatic Filtration



Media color may be either green or white.



HARMSCO® Filtration Products



Made in USA

Specifications

- ▶ **Micron Ratings:** Nominal micron ratings of 20 and 50.
- ▶ **Filter Media:** Antimicrobial media with Silver Zeolite fibers.
- ▶ **Center Tubes:** ABS or PVC.
- ▶ **End Caps:** Pliable PVC with sealing surface built-in.
- ▶ **Temperature:** 140°F (60°C) temperature limit.*
- ▶ **Shrink Wrap:** Standard for all antimicrobial cartridges.

* Temperature limits vary and depend on pressure and time under load.

Featuring
**Agion Silver Zeolite
Antimicrobial Technology**
to protect cartridge media.

EPA Registration No. 71227-1-72854
EPA Establishment No. 72854-MA-001

Antimicrobial Filter Media inhibits growth of algae and bacteria biofilms on the filter cartridge.

Cleanable/Reusable in most filtration applications and micron ratings

Cartridge Selection/Sizing Guide

Available in 20 and 50 Micron Ratings

Cartridge Length	Product Code	Nominal Micron Rating	Media (sq ft)	Recommended Flow Rate* (GPM)	Length (in)	O.D. (in)	No./Case
SureSafe™ Cartridges (2-3/4" OD)							
9-3/4"	801-20-AM	20	6	6	9-3/4"	2-3/4	24
	801-50-AM	50	6	6	9-3/4"	2-3/4	24
Calypto Blue™ SureSafe™ Cartridges (4-1/2" OD)							
9-3/4"	HB-10-20W-AM	20	12	12	9-3/4"	4-1/2	8
	HB-10-50W-AM	50	12	12	9-3/4"	4-1/2	8
20"	HB-20-20W-AM	20	26	26	20"	4-1/2	4
	HB-20-50W-AM	50	26	26	20"	4-1/2	4
Hurricane® and WaterBetter® SureSafe™ Cartridges (7-3/4" OD)							
9-5/8"	HC/40-20-AM	20	40	35	9-5/8"	7-3/4	1
	HC/40-50-AM	50	40	35	9-5/8"	7-3/4	1
19-1/2"	HC/90-20-AM	20	90	70	19-1/2"	7-3/4	1
	HC/90-50-AM	50	90	70	19-1/2"	7-3/4	1
30-3/4"	HC/170-20-AM	20	170	105	30-3/4"	7-3/4	1
	HC/170-50-AM	50	170	105	30-3/4"	7-3/4	1

Individually shrink wrapped.



HC/170-50-AM

Premium quality cartridges are made of pleated polyester with Silver Zeolite fibers for long life and high dirt-holding capacity.

Harmsco® SureSafe™ Cartridges utilize Silver Zeolite technology. Combining inert organic materials with silver into our filter media enables our cartridges to help reduce odor-causing bacteria and inhibit growth of destructive mold and mildew on the filter cartridge.

Harmsco® SureSafe™ Media is interwoven with the latest in Silver Zeolite technology. Unlike competitive "treated media" products, Harmsco® SureSafe™ cartridges will continue to provide safety and protection for your customers while outlasting the competition.

Note: This publication is to be used as a guide. The data within has been obtained from many sources and is considered to be accurate. Harmsco does not assume liability for the accuracy and/or completeness of this data. Changes to the data can be made without notification. Temperature, Pressure, Flow Rates, Differential Pressures, Chemical Combinations and other unknown factors can affect performance in unknown ways. **Limited Warranty:** Harmsco warrants their products to be free of material and workmanship defects. Determination of suitability of Harmsco products for uses and applications contemplated by Buyer shall be the sole responsibility of Buyer. The end user/installer/buyer shall be liable for the product's performance and suitability regarding their specific intended applications. End users should perform their own tests to determine suitability for each application.



HARMSCO® Filtration Products

P.O. Box 14066, North Palm Beach, FL 33408

(561) 848-9628 • Toll-free: (800) 327-3248 • Fax: (561) 845-2474 • E-mail: sales@harmsco.com

www.harmsco.com



Made in USA

© Harmsco, Inc. 36A 17 7/11

HARMSCO®

Poly-Pleat™ Series Filter Cartridges

Absolute Rated

Designed for Filter Housings That Utilize 2-1/2", 2-3/4", 4-1/2" and 7-3/4" O.D. High Flow Cartridges.

CERTIFIED: NSF/ANSI STANDARD 61

Drinking Water System Components - Health Effects

- **Substantially removes:**
 - Cryptosporidium
 - Giardia cysts
 - Harmful organisms
 - Sediment
 - Silt
 - Turbidity



Certified to
ANSI-NSF 61



Harmsco® Poly-Pleat™ Series Filter Cartridges

Features

- ▶ Absolute rated one micron filter media removes cyst-sized particles for safe, cyst-free drinking water
- ▶ Pleated polypropylene filter media provides more surface area for longer filter life and increased particle removal
- ▶ FDA listed materials for use in potable water and liquid food applications
- ▶ End caps, center tubes and media are thermally bonded as one integral component for added strength and to provide superior end sealing
- ▶ Full product line for standard, Big-Blue* and Hurricane® filter housings

*Big-Blue is a registered trademark of Plymouth Products, Inc.

Applications

- ▶ Reverse Osmosis Pre-filtration
- ▶ Municipal Drinking Water Filtration
- ▶ Commercial/Residential Drinking Water Filtration
- ▶ Desalination Pre-filtration
- ▶ Industrial Water Filtration
- ▶ Chill Water Loop Filtration
- ▶ Food & Beverage Filtration
- ▶ Marine/Aquatic Filtration



HARMSCO® Filtration Products



Made in USA

Specifications

- ▶ **Micron rating** - One micron absolute for cryptosporidium and giardia cysts
- ▶ **Filter media** - Meltblown polypropylene inner layer with outer layers of polypropylene scrim material for support
- ▶ **Shrink Wrap** - Standard for all Poly-Pleat™ cartridges
- ▶ **Temperature** - 140°F (60°C) max*
- ▶ **Center tubes** - Rigid PVC with perforations or molded polypropylene
- ▶ **Netting** - Polypropylene netting standard for 2-3/4" O.D.; 10" and 20" cartridges use polyethylene netting
- ▶ **Flow Rates** - Up to .5 gpm ft² media
- ▶ **End Caps** - Pliable PVC, sealing surface built in

* Temperature limits vary and depend on pressure and time under load.

Independent Lab Validated

To verify the performance of Poly-Pleat™ cartridges and Harmsco® filter housings, Pace Analytical*, a highly respected independent testing facility, was selected to conduct challenge tests to the NSF 53-2007 protocol for cysts reduction. The NSF 53-2007 protocol consists of two side-by-side systems operating on a 10-minute on/10-minute off cycle. Polystyrene 3-micron beads were injected after the 8th cycle and at 25%, 50% and 75% reduction in flow rate. Results are listed on right:

* Pace Analytical is State Certified (CA, IA, MA, WI). Results are accepted by Water Quality Association (WQA), Underwriters Laboratory (UL) and Canadian Standards Association (CSA) for product label or seal programs.

Results of Challenge Tests

Sample Point	Particle Size (microns)	Percent Reduction
8th Cycle	3	99.92
25% Reduction	3	99.95
50% Reduction	3	99.96
75% Reduction	3	99.95



Certified to ANSI-NSF 61

Cartridge Selection/Sizing Guide

2-1/2", 2-3/4", 4-1/2" and 7-3/4" O.D. - Harmsco® HIF filter housings use 9-3/4", 19-1/2" and 29-1/4" lengths only

Cartridge O.D.

Product Code	Pleated Media Area (sq ft)	Type	Length (in.)	O.D. (in.)	Recommended Flow Rate (GPM) for 2 log removal	No./Carton
Poly-Pleat™ - 1 micron absolute, multi-layered media						
PP-701-1/10	3	Standard	10	2-1/2	1.5	28
PP-701-1/20	7	Standard	20	2-1/2	3.5	28
PP-701-1/30	11	Standard	30	2-1/2	5.5	28
PP-701-1/40	15	Standard	40	2-1/2	7.5	28
PP-S-1	3.7	Standard	9-3/4	2-3/4	1.85	24
PP-D-1	7.5	Standard	19-1/2	2-3/4	3.75	24
PP-T-1	11	Standard	29-1/4	2-3/4	5.5	24
PP-20E-1	7.5	Standard	20	2-3/4	3.75	24
PP-BB-10-1	8	Calypso Blue™	9-3/4	4-1/2	4	8
PPFS-BB-10-1	8	Calypso Blue™	9-3/4	4-1/2	4	8
PPFS-BB-20-1	20	Calypso Blue™	20	4-1/2	10	4
PP-BB-20-1	20	Calypso Blue™	20	4-1/2	10	4
PP-BB-20-1	20	Calypso Blue™	20	4-1/2	10	4
PP-HC-40-1	27	Hurricane®	9-5/8	7-3/4	13.5	1
PPFS-HC-40-1	27	Hurricane®	9-5/8	7-3/4	13.5	1
PP-HC-90-1	58	Hurricane®	19-1/2	7-3/4	29	1
PPFS-HC-90-1	58	Hurricane®	19-1/2	7-3/4	29	1
PP-HC-170-1	100	Hurricane®	30-3/4	7-3/4	50	1
PPFS-HC-170-1	100	Hurricane®	30-3/4	7-3/4	50	1

Low Pressure Drop

Initial pressure drop using Poly-Pleat™ cartridges is exceptionally low due to our pleated design and increased surface area. Pressure drop data is shown here, calculated for new cartridges in clear water.

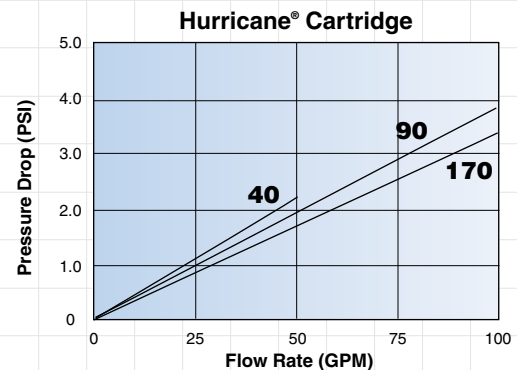
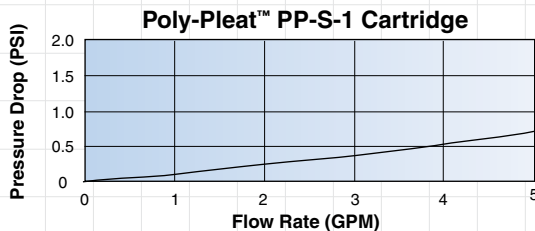

Note: This publication is to be used as a guide. The data within has been obtained from many sources and is considered to be accurate. Harmsco does not assume liability for the accuracy and/or completeness of this data. Changes to the data can be made without notification. Temperature, Pressure, Flow Rates, Differential Pressures, Chemical Combinations and other unknown factors can affect performance in unknown ways. **Limited Warranty:** Harmsco warrants their products to be free of material and workmanship defects. Determination of suitability of Harmsco products for uses and applications contemplated by Buyer shall be the sole responsibility of Buyer. The end user/installer/buyer shall be liable for the product's performance and suitability regarding their specific intended applications. End users should perform their own tests to determine suitability for each application.



HARMSCO® Filtration Products

P.O. Box 14066, North Palm Beach, FL 33408

(561) 848-9628 • Toll-free: (800) 327-3248 • Fax: (561) 845-2474 • E-mail: sales@harmsco.com

www.harmsco.com



Made in USA

© Harmsco, Inc. 30B 07 7/11

HARMSCO®

Premium Polyester Series Cartridges

Industrial Grade

Designed for HIF, BC, HMC and FSSS Filter Housings

Highly efficient filter cartridges made of pleated Polyester-Plus™ filter media. The industry's largest surface area.

- Lower overall operating cost
- Longer filter runs for fewer change outs
- Lower initial pressure drops
- Reduced maintenance down time and cost
- Increased contaminant removal
- High flow capability



Certified to
ANSI-NSF 61

Excluding High Temp

Features

- ▶ Pleated design for more surface area
- ▶ FDA approved materials - NSF 61 certified
- ▶ Engineered media for superior performance
- ▶ Cleanable and reusable in most applications and micron sizes
- ▶ Thermally bonded end caps to ensure better sealing
- ▶ Color coded end caps for easy micron identification
- ▶ Full product line - largest selection of micron ratings
- ▶ High Temperature cartridges available (not NSF 61 Listed)



Applications

- ▶ Reverse Osmosis Pre-filtration
- ▶ Municipal Drinking Water Filtration
- ▶ Commercial/Residential Drinking Water Filtration
- ▶ Desalination Pre-filtration
- ▶ Industrial Water Filtration
- ▶ Cooling Tower Filtration
- ▶ Chill Water Loop Filtration
- ▶ Food & Beverage Filtration
- ▶ Marine/Aquatic Filtration
- ▶ Industrial Coolant Filtration



HARMSCO® Filtration Products



Made in USA

Premium Polyester Series Cartridges

Specifications

- ▶ **Filter media** - Polyester-Plus™
- ▶ **Temperature** - 140°F (standard cartridges)
200°F (high temp. cartridges)
- ▶ **Dimensions** - 2-3/4" O.D.; 1-1/16" I.D.
- ▶ **Center tubes** - Molded ABS or rigid PVC
- ▶ **pH** - 3 to 11
- ▶ **Flow rate** - 4-6 GPM per 9-3/4" length
- ▶ **End caps** - Plastisol (pliablePVC),
except urethane on HT series
- ▶ **Surface area (801 Series)** - 6 sq.ft.
per 9-3/4" length (approx.)



Certified to
ANSI-NSF 61

Excluding High Temp

Cartridge Selection/Sizing Guide

2-3/4" O.D. Harmsco® HIF filter housings use 9-3/4", 19-1/2" and 29-1/4" length cartridges only.

Cartridge Length

Product Code	Nominal Micron Rating	Media (sq ft)	Recommended Flow Rate* (GPM)	Length (in)	O.D. (in)	No./Case
Polyester-Plus™ - engineered for high efficiency, low pressure drops						
801-0.35	0.35	6	6	9-3/4	2-3/4	24
801-1	1	6	6	9-3/4	2-3/4	24
801-5	5	6	6	9-3/4	2-3/4	24
801-10	10	6	6	9-3/4	2-3/4	24
801-20	20	6	6	9-3/4	2-3/4	24
801-50	50	6	6	9-3/4	2-3/4	24
801-100	100	6	6	9-3/4	2-3/4	24
921-0.35	0.35	12	12	19-1/2	2-3/4	24
921-1	1	12	12	19-1/2	2-3/4	24
921-5	5	12	12	19-1/2	2-3/4	24
921-10	10	12	12	19-1/2	2-3/4	24
921-20	20	12	12	19-1/2	2-3/4	24
921-50	50	12	12	19-1/2	2-3/4	24
801-0.35/20*	0.35	12	12	20	2-3/4	24
801-1/20	1	12	12	20	2-3/4	24
801-5/20*	5	12	12	20	2-3/4	24
801-20/20*	20	12	12	20	2-3/4	24
801-50/20	50	12	12	20	2-3/4	24
931-0.35	0.35	18	18	29-1/4	2-3/4	24
931-1	1	18	18	29-1/4	2-3/4	24
931-5	5	18	18	29-1/4	2-3/4	24
931-10	10	18	18	29-1/4	2-3/4	24
931-20	20	18	18	29-1/4	2-3/4	24
931-50	50	18	18	29-1/4	2-3/4	24
801-0.35/30*	0.35	18	18	30	2-3/4	24
801-1/30	1	18	18	30	2-3/4	24
801-5/30*	5	18	18	30	2-3/4	24
801-20/30*	20	18	18	30	2-3/4	24
801-50/30	50	18	18	30	2-3/4	24
801-0.35/40*	0.35	24	24	40	2-3/4	24
801-1/40	1	24	24	40	2-3/4	24
801-5/40*	5	24	24	40	2-3/4	24
801-20/40*	20	24	24	40	2-3/4	24
801-50/40	50	24	24	40	2-3/4	24

Polyester: High Temperature - rated up to 200°F (93°C); standard dark blue end caps

801-1-HT	1	6	6	9-3/4	2-3/4	24
801-5-HT	5	6	6	9-3/4	2-3/4	24
801-20-HT	20	6	6	9-3/4	2-3/4	24
801-50-HT	50	6	6	9-3/4	2-3/4	24

* Add suffix "W" if wrapped (ex. "801-0.35/20W")

Low Pressure Drop With Harmsco® Cartridges

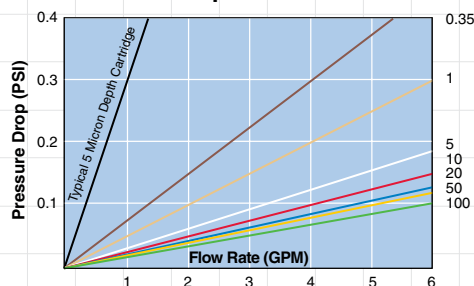

Nominal Micron	0.35	1	5	10	20	50	100
End Cap	Brown	Tan	White	Red	Blue	Yellow	Green

Graph colors (left) correspond with color codes (above) used to identify nominal micron rating of cartridge.

Pressure drops are exceptionally low with Premium Series cartridges due to high surface area and Polyester-Plus™ engineered media. The data shown (left) is per new 9-3/4" cartridge in clean water.

Note: This publication is to be used as a guide. The data within has been obtained from many sources and is considered to be accurate. Harmsco does not assume liability for the accuracy and/or completeness of this data. Changes to the data can be made without notification. Temperature, Pressure, Flow Rates, Differential Pressures, Chemical Combinations and other unknown factors can affect performance in unknown ways. **Limited Warranty:** Harmsco warrants their products to be free of material and workmanship defects. Determination of suitability of Harmsco products for uses and applications contemplated by Buyer shall be the sole responsibility of Buyer. The end user/installer/buyer shall be liable for the product's performance and suitability regarding their specific intended applications. End users should perform their own tests to determine suitability for each application.



HARMSCO® Filtration Products

P.O. Box 14066, North Palm Beach, FL 33408

(561) 848-9628 • Toll-free: (800) 327-3248 • Fax: (561) 845-2474 • E-mail: sales@harmsco.com

www.harmsco.com



Made in USA

© Harmsco, Inc. 21B 23 7/11

HARMSCO®

WaterBetter® Polyester Series Cartridges

Residential / Commercial

Designed for HIF, BC and FSSS Filter Housings

Highly efficient and economical filter cartridges made of pleated Polyester-Plus™ filter media.

- Lower overall operating cost
 - Longer filter runs for fewer change outs
 - Lower initial pressure drops
 - Reduced maintenance down time and cost
 - Increased contaminant removal
 - High flow capability



Certified to
ANSI-NSF 61

Features

- ▶ Pleated design for more surface area
- ▶ FDA approved materials - NSF 61 certified
- ▶ Engineered media for superior performance
- ▶ Cleanable and reusable in most applications and micron sizes
- ▶ Thermally bonded end caps to ensure better sealing
- ▶ Color coded end caps for easy micron identification
- ▶ Full product line - largest selection of micron ratings



Applications

- ▶ Reverse Osmosis Pre-filtration
- ▶ Municipal Drinking Water Filtration
- ▶ Commercial/Residential Drinking Water Filtration
- ▶ Desalination Pre-filtration
- ▶ Industrial Water Filtration
- ▶ Cooling Tower Filtration
- ▶ Chill Water Loop Filtration
- ▶ Food & Beverage Filtration
- ▶ Marine/Aquatic Filtration



HARMSCO® Filtration Products



Made in USA

WaterBetter® Polyester Series Cartridges

Specifications

- ▶ **Filter media:** Polyester-Plus™
- ▶ **Temperature:** 140°F (standard cartridges)
- ▶ **Dimensions:** 2-3/4" O.D.; 1-1/16" I.D.
- ▶ **Center cores:** Molded ABS or rigid PVC
- ▶ **pH:** 3 to 11
- ▶ **Flow rate:** 3-5 GPM
- ▶ **End caps:** Plastisol (pliablePVC)
- ▶ **Surface area:** 4 sq.ft. per 9-3/4" length (approx.)



Certified to
ANSI-NSF 61

Cartridge Selection/Sizing Guide

2-3/4" O.D. Harmsco® HIF filter housings use 9-3/4", 19-1/2" and 29-1/4" length cartridges only.

Cartridge Length

Product Code	Nominal Micron Rating	Media (sq ft)	Recommended Flow Rate* (GPM)	Length (in)	O.D. (in)	No./Case
Polyester-Plus™ - engineered for high efficiency, low pressure drops						
WB-1W*	1	4	4	9-3/4	2-3/4	24
WB-5W*	5	4	4	9-3/4	2-3/4	24
WB-20W*	20	4	4	9-3/4	2-3/4	24
WB-50W*	50	4	4	9-3/4	2-3/4	24
WB-921-1	1	8	8	19-1/2	2-3/4	24
WB-921-5	5	8	8	19-1/2	2-3/4	24
WB-921-20	20	8	8	19-1/2	2-3/4	24
WB-921-50	50	8	8	19-1/2	2-3/4	24
WB-20-1W*	1	8	8	20	2-3/4	24
WB-20-5W*	5	8	8	20	2-3/4	24
WB-20-20W*	20	8	8	20	2-3/4	24
WB-20-50W*	50	8	8	20	2-3/4	24
WB-931-1	1	12	12	29-1/4	2-3/4	24
WB-931-5	5	12	12	29-1/4	2-3/4	24
WB-931-20	20	12	12	29-1/4	2-3/4	24
WB-931-50	50	12	12	29-1/4	2-3/4	24

* "W" indicates wrapped.

Low Pressure Drop With Harmsco® Cartridges

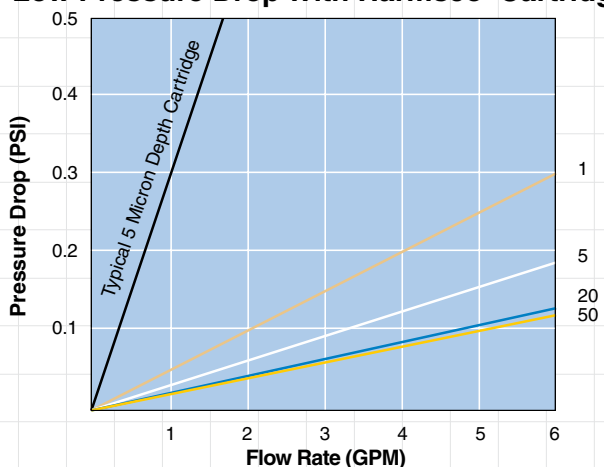

Four micron ratings and color coded end caps for easy identification.



Graph colors (left) correspond with color codes (above) used to identify nominal micron rating of cartridge.

Pressure drops are exceptionally low with WaterBetter® Series cartridges due to high surface area and Polyester-Plus™ engineered media. The data shown (left) is per new 9-3/4" cartridge in clean water.

Note: This publication is to be used as a guide. The data within has been obtained from many sources and is considered to be accurate. Harmsco does not assume liability for the accuracy and/or completeness of this data. Changes to the data can be made without notification. Temperature, Pressure, Flow Rates, Differential Pressures, Chemical Combinations and other unknown factors can affect performance in unknown ways. **Limited Warranty:** Harmsco warrants their products to be free of material and workmanship defects. Determination of suitability of Harmsco products for uses and applications contemplated by Buyer shall be the sole responsibility of Buyer. The end user/installer/buyer shall be liable for the product's performance and suitability regarding their specific intended applications. End users should perform their own tests to determine suitability for each application.



HARMSCO® Filtration Products

P.O. Box 14066, North Palm Beach, FL 33408

(561) 848-9628 • Toll-free: (800) 327-3248 • Fax: (561) 845-2474 • E-mail: sales@harmsco.com

www.harmsco.com



Made in USA

© Harmsco, Inc. 24A 12 7/11

HARMSCO®

Premium 701 Series Filter Cartridges

Industrial Grade

Designed for Housings That Utilize 2-1/2" O.D. Cartridges, and Harmsco® FSSS, BC and HMC Filter Housings

Highly efficient filter cartridges made of pleated Polyester-Plus™ filter media. The industry's largest surface area.

- Lower overall operating cost
- Longer filter runs for fewer change outs
- Lower initial pressure drops
- Reduced maintenance down time and cost
- Increased contaminant removal
- High flow capability



Certified to
ANSI-NSF 61

Features

- ▶ Pleated filter media provides higher flow rates and lower initial pressure drop
- ▶ Pleated filters offer more surface area providing higher loading capacity for longer filter life and increased particle removal
- ▶ End cap, center tubes and media are thermally bonded as one integral component for added strength
- ▶ Offered in Polyester-Plus™, Harmsco-Free and Poly-Pleat™ media types
- ▶ Color coded end caps for easy micron identification



Applications

- ▶ Reverse Osmosis Pre-filtration
- ▶ Municipal Drinking Water Filtration
- ▶ Commercial/Residential Drinking Water Filtration
- ▶ Desalination Pre-filtration
- ▶ Industrial Water Filtration
- ▶ Cooling Tower Filtration
- ▶ Chill Water Loop Filtration
- ▶ Food & Beverage Filtration
- ▶ Marine/Aquatic Filtration



HARMSCO® Filtration Products



Made in USA

Premium 701 Series Filter Cartridges

Specifications

- ▶ **Filter media:** Polyester-Plus™, Synthetic and Polypropylene
- ▶ **Center Core:** Rigid PVC with perforations or polypropylene
- ▶ **Outer Support Media:** Polypropylene
- ▶ **Temperature:** 140°F (60°C)
- ▶ **Shrink Wrap:** Standard on all cartridges
- ▶ **End Caps:** Pliable PVC, sealing surface built in
- ▶ **Change Out:** 25 PSI ΔP (1.7 bar)
- ▶ **pH:** 3 to 11



Certified to ANSI-NSF 61

Cartridge Selection/Sizing Guide

2-1/2" O.D.

Cartridge Length

Product Code	Nominal Micron Rating	Media (sq ft)	Recommended Flow Rate* (GPM)	Length (in)	O.D. (in)	No./Case
Polyester-Plus™ - engineered for high efficiency, low pressure drops						
701-0.35	0.35	5	4	9-3/4	2-1/2	28
701-1	1	5	4	9-3/4	2-1/2	28
701-5	5	5	4	9-3/4	2-1/2	28
701-20	20	5	4	9-3/4	2-1/2	28
701-50	50	5	4	9-3/4	2-1/2	28
701-0.35/10	0.35	5	4	10	2-1/2	28
701-1/10	1	5	4	10	2-1/2	28
701-5/10	5	5	4	10	2-1/2	28
701-20/10	20	5	4	10	2-1/2	28
701-50/10	50	5	4	10	2-1/2	28
701-0.35/20	0.35	10	8	20	2-1/2	28
701-1/20	1	10	8	20	2-1/2	28
701-5/20	5	10	8	20	2-1/2	28
701-20/20	20	10	8	20	2-1/2	28
701-50/20	50	10	8	20	2-1/2	28
701-0.35/30	0.35	15	12	30	2-1/2	28
701-1/30	1	15	12	30	2-1/2	28
701-5/30	5	15	12	30	2-1/2	28
701-20/30	20	15	12	30	2-1/2	28
701-50/30	50	15	12	30	2-1/2	28
701-0.35/40	0.35	20	16	40	2-1/2	28
701-1/40	1	20	16	40	2-1/2	28
701-5/40	5	20	16	40	2-1/2	28
701-20/40	20	20	16	40	2-1/2	28
701-50/40	50	20	16	40	2-1/2	28
Harmsco-Free - 100% synthetic composite media						
701-1/10-HF	1	5	4	10	2-1/2	28
701-5/10-HF	5	5	4	10	2-1/2	28
701-20/10-HF	20	5	4	10	2-1/2	28
701-1/20-HF	1	10	8	20	2-1/2	28
701-5/20-HF	5	10	8	20	2-1/2	28
701-20/20-HF	20	10	8	20	2-1/2	28
701-1/30-HF	1	15	12	30	2-1/2	28
701-5/30-HF	5	15	12	30	2-1/2	28
701-20/30-HF	20	15	12	30	2-1/2	28
701-1/40-HF	1	20	16	40	2-1/2	28
701-5/40-HF	5	20	16	40	2-1/2	28
701-20/40-HF	20	20	16	40	2-1/2	28
Poly-Pleat™ - 1 micron absolute, multi-layered media						
PP-701-1/10	1	3	1.5	10	2-1/2	28
PP-701-1/20	1	7	3.5	20	2-1/2	28
PP-701-1/30	1	11	5.5	30	2-1/2	28
PP-701-1/40	1	15	7.5	40	2-1/2	28



Nominal Micron	0.35	1	5	20	50
End Cap	Brown	Tan	White	Blue	Yellow

Five micron ratings and color coded end caps for easy identification.

Note: This publication is to be used as a guide. The data within has been obtained from many sources and is considered to be accurate. Harmsco does not assume liability for the accuracy and/or completeness of this data. Changes to the data can be made without notification. Temperature, Pressure, Flow Rates, Differential Pressures, Chemical Combinations and other unknown factors can affect performance in unknown ways. **Limited Warranty:** Harmsco warrants their products to be free of material and workmanship defects. Determination of suitability of Harmsco products for uses and applications contemplated by Buyer shall be the sole responsibility of Buyer. The end user/installer/buyer shall be liable for the product's performance and suitability regarding their specific intended applications. End users should perform their own tests to determine suitability for each application.



HARMSCO® Filtration Products

P.O. Box 14066, North Palm Beach, FL 33408

(561) 848-9628 • Toll-free: (800) 327-3248 • Fax: (561) 845-2474 • E-mail: sales@harmsco.com

www.harmsco.com



Made in USA

© Harmsco, Inc. 22A 13 7/11

HARMSCO®

Calypso Blue™ Cartridges

Industrial and Residential

Premium and WaterBetter® Series

Designed for 4-1/2" diameter filter housings.



Certified to
ANSI-NSF 61

- Lower overall operating cost
- Longer filter runs for fewer change outs
- Lower initial pressure drops
- Reduced maintenance down time and cost
- Increased contaminant removal
- High flow capability

Features

- ▶ Pleated design for more surface area
- ▶ FDA approved materials - NSF 61 certified
- ▶ Engineered media for superior performance
- ▶ Cleanable and reusable in most applications and micron sizes
- ▶ Thermally bonded end caps to ensure better sealing
- ▶ Full product line - largest selection of micron ratings



Applications

- ▶ Reverse Osmosis Pre-filtration
- ▶ Municipal Drinking Water Filtration
- ▶ Commercial/Residential Drinking Water Filtration
- ▶ Desalination Pre-filtration
- ▶ Industrial Water Filtration
- ▶ Cooling Tower Filtration
- ▶ Chill Water Loop Filtration
- ▶ Food & Beverage Filtration
- ▶ Marine/Aquatic Filtration



HARMSCO® Filtration Products



Made in USA

Specifications

- ▶ **Nominal Micron Ratings:** 0.35, 1, 5, 20, 50 microns;
Absolute Micron Rating: 1 micron
- ▶ **Filter Media:** Polyester-Plus™, Synthetic Fiber
- ▶ **End Caps:** Pliable PVC or Urethane
- ▶ **Shrink Wrap:** Standard on all Premium and WaterBetter® Calypso cartridges
- ▶ **Temperature:** up to 140°F (60°C)
- ▶ **Center Tubes:** ABS or PVC



Certified to
ANSI-NSF 61

Cartridge Selection/Sizing Guide

9-3/4"

20"

4-1/2" O.D. 9-3/4" and 20" Calypso Blue™ Cartridges - Premium and WaterBetter®

Product Code	Nominal Micron Rating	Media (sq ft)	Maximum Flow Rate* (GPM)	Length (in)	O.D. (in)	No./Case
Polyester-Plus™ - engineered for high efficiency, low pressure drops						
HB-10-0.35W	0.35	12	12	9-3/4	4-1/2	8
HB-10-1W	1	12	12	9-3/4	4-1/2	8
HB-10-5W	5	12	12	9-3/4	4-1/2	8
HB-10-20W	20	12	12	9-3/4	4-1/2	8
HB-10-50W	50	12	12	9-3/4	4-1/2	8
HB-20-0.35W	0.35	26	26	20	4-1/2	4
HB-20-1W	1	26	26	20	4-1/2	4
HB-20-5W	5	26	26	20	4-1/2	4
HB-20-20W	20	26	26	20	4-1/2	4
HB-20-50W	50	26	26	20	4-1/2	4
Harmsco-Free - 100% synthetic composite media						
HB-10-1W-HF	1	8	8	9-3/4	4-1/2	8
HB-10-5W-HF	5	8	8	9-3/4	4-1/2	8
HB-10-20W-HF	20	8	8	9-3/4	4-1/2	8
HB-20-1W-HF	1	20	20	20	4-1/2	4
HB-20-5W-HF	5	20	20	20	4-1/2	4
HB-20-20W-HF	20	20	20	20	4-1/2	4
Poly-Pleat™ - absolute, multi-layered media						
PP-BB-10-1	1	8	4	9-3/4	4-1/2	8
PPFS-BB-10-1	1	8	4	9-3/4	4-1/2	8
PP-BB-20-1	1	20	10	20	4-1/2	4
PPFS-BB-20-1	1	20	10	20	4-1/2	4
SureSafe™ Antimicrobial - reduces growth of bacteria and mold on media						
HB-10-20W-AM	20	12	12	9-3/4	4-1/2	8
HB-10-50W-AM	50	12	12	9-3/4	4-1/2	8
HB-20-20W-AM	20	26	26	20	4-1/2	4
HB-20-50W-AM	50	26	26	20	4-1/2	4
EZ-Clean - 100% synthetic composite 50 micron media						
HB-10-EZ-CLEAN	30	12	12	9-3/4	4-1/2	8
HB-20-EZ-CLEAN	30	26	26	20	4-1/2	4
WaterBetter® Polyester - economy grade						
WB-HB-10-1W	1	9.5	10	9-3/4	4-1/2	8
WB-HB-10-5W	5	9.5	10	9-3/4	4-1/2	8
WB-HB-10-20W	20	9.5	10	9-3/4	4-1/2	8
WB-HB-10-50W	50	9.5	10	9-3/4	4-1/2	8
WB-HB-20-1W	1	21	20	20	4-1/2	4
WB-HB-20-5W	5	21	20	20	4-1/2	4
WB-HB-20-20W	20	21	20	20	4-1/2	4
WB-HB-20-50W	50	21	20	20	4-1/2	4

* Harmsco recommends operation at 50-70% of maximum flow rate for optimum performance.

Note: This publication is to be used as a guide. The data within has been obtained from many sources and is considered to be accurate. Harmsco does not assume liability for the accuracy and/or completeness of this data. Changes to the data can be made without notification. Temperature, Pressure, Flow Rates, Differential Pressures, Chemical Combinations and other unknown factors can affect performance in unknown ways. **Limited Warranty:** Harmsco warrants their products to be free of material and workmanship defects. Determination of suitability of Harmsco products for uses and applications contemplated by Buyer shall be the sole responsibility of Buyer. The end user/installer/buyer shall be liable for the product's performance and suitability regarding their specific intended applications. End users should perform their own tests to determine suitability for each application.



HARMSCO® Filtration Products

P.O. Box 14066, North Palm Beach, FL 33408

(561) 848-9628 • Toll-free: (800) 327-3248 • Fax: (561) 845-2474 • E-mail: sales@harmsco.com

www.harmsco.com



Made in USA

© Harmsco, Inc. 32B 15 7/11

Premium Series

WaterBetter

HARMSCO®

Premium SureSafe™ Cartridges

Antimicrobial Media

Designed for HIF, Band Clamp, Hurricane®, WaterBetter® Calypso Blue™ and Single Filter Housings.

Harmsco® SureSafe™ cartridges are fabricated with the latest in Silver Zeolite technology and provide antimicrobial protection on the cartridge, outlasting the competition.

- Lower overall operating cost
- Inhibits growth of algae & bacteria on the media
- Longer filter runs for fewer change-outs
- Lower pressure drops
- Reduced maintenance down time and cost
- Increased contaminant removal
- Easy to install, remove, clean and replace

Agion Silver Zeolite is
FDA Tested and EPA Registered

EPA Registration No. 71227-1-72854
EPA Establishment No. 72854-MA-001



Features

- ▶ Pleated design for more surface area
- ▶ Utilizes Agion Silver Zeolite fibers
- ▶ Agion Silver Zeolite is effective against more than 650 strains of bacteria, fungi and mold
- ▶ Agion Silver Zeolite is FDA tested and registered with the EPA
- ▶ Engineered media for superior performance
- ▶ Cleanable and reusable in most applications and micron ratings

Applications

- ▶ Pre-Reverse Osmosis Filtration
- ▶ Boiler Make-up Water Filtration
- ▶ Chill Water Loop Filtration
- ▶ Cooling Tower Filtration
- ▶ Surface Water Filtration
- ▶ Well Water
- ▶ Salt Water/Desalination Filtration
- ▶ Industrial Waste Water Filtration
- ▶ Pre-filter for Carbon Filters
- ▶ Marine/Aquatic Filtration



Media color may be either green or white.



HARMSCO® Filtration Products



Made in USA

Specifications

- ▶ **Micron Ratings:** Nominal micron ratings of 20 and 50.
- ▶ **Filter Media:** Antimicrobial media with Silver Zeolite fibers.
- ▶ **Center Tubes:** ABS or PVC.
- ▶ **End Caps:** Pliable PVC with sealing surface built-in.
- ▶ **Temperature:** 140°F (60°C) temperature limit.*
- ▶ **Shrink Wrap:** Standard for all antimicrobial cartridges.

* Temperature limits vary and depend on pressure and time under load.

Featuring
**Agion Silver Zeolite
Antimicrobial Technology**
to protect cartridge media.

EPA Registration No. 71227-1-72854
EPA Establishment No. 72854-MA-001

Antimicrobial Filter Media inhibits growth of algae and bacteria biofilms on the filter cartridge.

Cleanable/Reusable in most filtration applications and micron ratings

Cartridge Selection/Sizing Guide

Available in 20 and 50 Micron Ratings

Cartridge Length	Product Code	Nominal Micron Rating	Media (sq ft)	Recommended Flow Rate* (GPM)	Length (in)	O.D. (in)	No./Case
SureSafe™ Cartridges (2-3/4" OD)							
9-3/4"	801-20-AM	20	6	6	9-3/4"	2-3/4	24
	801-50-AM	50	6	6	9-3/4"	2-3/4	24
Calypto Blue™ SureSafe™ Cartridges (4-1/2" OD)							
9-3/4"	HB-10-20W-AM	20	12	12	9-3/4"	4-1/2	8
	HB-10-50W-AM	50	12	12	9-3/4"	4-1/2	8
20"	HB-20-20W-AM	20	26	26	20"	4-1/2	4
	HB-20-50W-AM	50	26	26	20"	4-1/2	4
Hurricane® and WaterBetter® SureSafe™ Cartridges (7-3/4" OD)							
9-5/8"	HC/40-20-AM	20	40	35	9-5/8"	7-3/4	1
	HC/40-50-AM	50	40	35	9-5/8"	7-3/4	1
19-1/2"	HC/90-20-AM	20	90	70	19-1/2"	7-3/4	1
	HC/90-50-AM	50	90	70	19-1/2"	7-3/4	1
30-3/4"	HC/170-20-AM	20	170	105	30-3/4"	7-3/4	1
	HC/170-50-AM	50	170	105	30-3/4"	7-3/4	1

Individually shrink wrapped.



HC/170-50-AM

Premium quality cartridges are made of pleated polyester with Silver Zeolite fibers for long life and high dirt-holding capacity.

Harmsco® SureSafe™ Cartridges utilize Silver Zeolite technology. Combining inert organic materials with silver into our filter media enables our cartridges to help reduce odor-causing bacteria and inhibit growth of destructive mold and mildew on the filter cartridge.

Harmsco® SureSafe™ Media is interwoven with the latest in Silver Zeolite technology. Unlike competitive "treated media" products, Harmsco® SureSafe™ cartridges will continue to provide safety and protection for your customers while outlasting the competition.

Note: This publication is to be used as a guide. The data within has been obtained from many sources and is considered to be accurate. Harmsco does not assume liability for the accuracy and/or completeness of this data. Changes to the data can be made without notification. Temperature, Pressure, Flow Rates, Differential Pressures, Chemical Combinations and other unknown factors can affect performance in unknown ways. **Limited Warranty:** Harmsco warrants their products to be free of material and workmanship defects. Determination of suitability of Harmsco products for uses and applications contemplated by Buyer shall be the sole responsibility of Buyer. The end user/installer/buyer shall be liable for the product's performance and suitability regarding their specific intended applications. End users should perform their own tests to determine suitability for each application.



HARMSCO® Filtration Products

P.O. Box 14066, North Palm Beach, FL 33408

(561) 848-9628 • Toll-free: (800) 327-3248 • Fax: (561) 845-2474 • E-mail: sales@harmsco.com

www.harmsco.com



Made in USA

© Harmsco, Inc. 36A 17 7/11

HARMSCO®

Poly-Pleat™ Series Filter Cartridges

Absolute Rated

Designed for Filter Housings That Utilize 2-1/2", 2-3/4", 4-1/2" and 7-3/4" O.D. High Flow Cartridges.

CERTIFIED: NSF/ANSI STANDARD 61

Drinking Water System Components - Health Effects

- **Substantially removes:**
 - Cryptosporidium
 - Giardia cysts
 - Harmful organisms
 - Sediment
 - Silt
 - Turbidity



Certified to
ANSI-NSF 61



Harmsco® Poly-Pleat™ Series Filter Cartridges

Features

- ▶ Absolute rated one micron filter media removes cyst-sized particles for safe, cyst-free drinking water
- ▶ Pleated polypropylene filter media provides more surface area for longer filter life and increased particle removal
- ▶ FDA listed materials for use in potable water and liquid food applications
- ▶ End caps, center tubes and media are thermally bonded as one integral component for added strength and to provide superior end sealing
- ▶ Full product line for standard, Big-Blue* and Hurricane® filter housings

*Big-Blue is a registered trademark of Plymouth Products, Inc.

Applications

- ▶ Reverse Osmosis Pre-filtration
- ▶ Municipal Drinking Water Filtration
- ▶ Commercial/Residential Drinking Water Filtration
- ▶ Desalination Pre-filtration
- ▶ Industrial Water Filtration
- ▶ Chill Water Loop Filtration
- ▶ Food & Beverage Filtration
- ▶ Marine/Aquatic Filtration



HARMSCO® Filtration Products



Made in USA

Specifications

- ▶ **Micron rating** - One micron absolute for cryptosporidium and giardia cysts
- ▶ **Filter media** - Meltblown polypropylene inner layer with outer layers of polypropylene scrim material for support
- ▶ **Shrink Wrap** - Standard for all Poly-Pleat™ cartridges
- ▶ **Temperature** - 140°F (60°C) max*
- ▶ **Center tubes** - Rigid PVC with perforations or molded polypropylene
- ▶ **Netting** - Polypropylene netting standard for 2-3/4" O.D.; 10" and 20" cartridges use polyethylene netting
- ▶ **Flow Rates** - Up to .5 gpm ft² media
- ▶ **End Caps** - Pliable PVC, sealing surface built in

* Temperature limits vary and depend on pressure and time under load.

Independent Lab Validated

To verify the performance of Poly-Pleat™ cartridges and Harmsco® filter housings, Pace Analytical*, a highly respected independent testing facility, was selected to conduct challenge tests to the NSF 53-2007 protocol for cysts reduction. The NSF 53-2007 protocol consists of two side-by-side systems operating on a 10-minute on/10-minute off cycle. Polystyrene 3-micron beads were injected after the 8th cycle and at 25%, 50% and 75% reduction in flow rate. Results are listed on right:

* Pace Analytical is State Certified (CA, IA, MA, WI). Results are accepted by Water Quality Association (WQA), Underwriters Laboratory (UL) and Canadian Standards Association (CSA) for product label or seal programs.

Results of Challenge Tests

Sample Point	Particle Size (microns)	Percent Reduction
8th Cycle	3	99.92
25% Reduction	3	99.95
50% Reduction	3	99.96
75% Reduction	3	99.95



Certified to ANSI-NSF 61

Cartridge Selection/Sizing Guide

2-1/2", 2-3/4", 4-1/2" and 7-3/4" O.D. - Harmsco® HIF filter housings use 9-3/4", 19-1/2" and 29-1/4" lengths only

Cartridge O.D.

Product Code	Pleated Media Area (sq ft)	Type	Length (in.)	O.D. (in.)	Recommended Flow Rate (GPM) for 2 log removal	No./Carton
Poly-Pleat™ - 1 micron absolute, multi-layered media						
PP-701-1/10	3	Standard	10	2-1/2	1.5	28
PP-701-1/20	7	Standard	20	2-1/2	3.5	28
PP-701-1/30	11	Standard	30	2-1/2	5.5	28
PP-701-1/40	15	Standard	40	2-1/2	7.5	28
PP-S-1	3.7	Standard	9-3/4	2-3/4	1.85	24
PP-D-1	7.5	Standard	19-1/2	2-3/4	3.75	24
PP-T-1	11	Standard	29-1/4	2-3/4	5.5	24
PP-20E-1	7.5	Standard	20	2-3/4	3.75	24
PP-BB-10-1	8	Calypso Blue™	9-3/4	4-1/2	4	8
PPFS-BB-10-1	8	Calypso Blue™	9-3/4	4-1/2	4	8
PPFS-BB-20-1	20	Calypso Blue™	20	4-1/2	10	4
PP-BB-20-1	20	Calypso Blue™	20	4-1/2	10	4
PP-BB-20-1	20	Calypso Blue™	20	4-1/2	10	4
PP-HC-40-1	27	Hurricane®	9-5/8	7-3/4	13.5	1
PPFS-HC-40-1	27	Hurricane®	9-5/8	7-3/4	13.5	1
PP-HC-90-1	58	Hurricane®	19-1/2	7-3/4	29	1
PPFS-HC-90-1	58	Hurricane®	19-1/2	7-3/4	29	1
PP-HC-170-1	100	Hurricane®	30-3/4	7-3/4	50	1
PPFS-HC-170-1	100	Hurricane®	30-3/4	7-3/4	50	1

Low Pressure Drop

Initial pressure drop using Poly-Pleat™ cartridges is exceptionally low due to our pleated design and increased surface area. Pressure drop data is shown here, calculated for new cartridges in clear water.

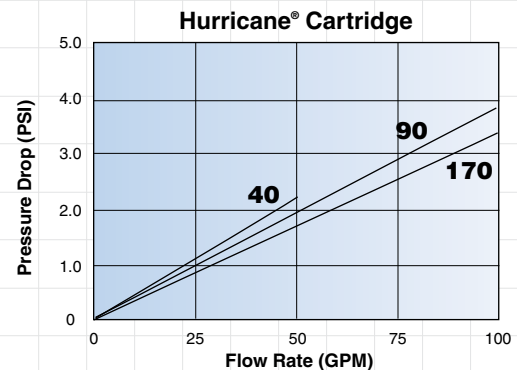
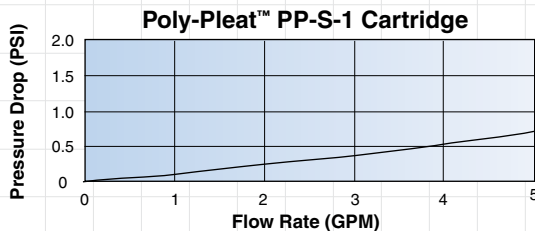

Note: This publication is to be used as a guide. The data within has been obtained from many sources and is considered to be accurate. Harmsco does not assume liability for the accuracy and/or completeness of this data. Changes to the data can be made without notification. Temperature, Pressure, Flow Rates, Differential Pressures, Chemical Combinations and other unknown factors can affect performance in unknown ways. **Limited Warranty:** Harmsco warrants their products to be free of material and workmanship defects. Determination of suitability of Harmsco products for uses and applications contemplated by Buyer shall be the sole responsibility of Buyer. The end user/installer/buyer shall be liable for the product's performance and suitability regarding their specific intended applications. End users should perform their own tests to determine suitability for each application.



HARMSCO® Filtration Products

P.O. Box 14066, North Palm Beach, FL 33408

(561) 848-9628 • Toll-free: (800) 327-3248 • Fax: (561) 845-2474 • E-mail: sales@harmsco.com

www.harmsco.com



Made in USA

© Harmsco, Inc. 30B 07 7/11

HARMSCO®

Premium Carbon Cartridges

Chlorine and Lead Reduction

Dual-stage Carbon Cartridges for Taste, Odor, Chlorine and Lead Reduction



COMPONENT

Models HAC-10-W, HAC-20-W and HAC-10-LR-W are tested and Certified by NSF International against NSF/ANSI Standard 42 for materials requirements only

- High chlorine reduction
- Low initial pressure drop
- Increased contaminant removal
- No release of carbon fines
- High dirt holding capacity
- No channeling or bypass

Features

- ▶ 100% coconut shell carbon
- ▶ Made from polyolefin filter media
- ▶ Dual stage depth filtration
- ▶ Heat fused inner layer
- ▶ 5-micron nominal filtration
- ▶ FDA approved components
- ▶ Radial flow design
- ▶ Available in a variety of sizes and flow rates



Applications

- ▶ Commercial Drinking Water
- ▶ Marine/Aquatic Filtration
- ▶ Food & Beverage Filtration
- ▶ Industrial Water Filtration
- ▶ Point of Entry Residential Filtration
- ▶ Reverse Osmosis Pre-filtration
- ▶ Water Bottling Filtration
- ▶ Science/Laboratory



HARMSCO® Filtration Products



Made in USA

Specifications

► **Filter Media:** Composite of pulverized activated carbon and polyolefin fibers bonded together with wet molding process and thermally bonded to eliminate channeling and media migration.

► **Temperature Limit:** 160°F (71°C)
 ► **Micron Rating:** 5 Nominal



COMPONENT

Models HAC-10-W, HAC-20-W and HAC-10-LR-W are tested and Certified by NSF International against NSF/ANSI Standard 42 for materials requirements only

Cartridge Selection/Sizing Guide

2-3/4 and 4-1/2" O.D. 9-3/4" and 20" Premium Carbon Cartridges

Product Code	Type	Max Flow Rate (GPM)	Max Flow Rate (LPM)	Max Capacity Chlorine (Gals.)	Max Capacity (Gals.) Organic Chemicals	Max Capacity Lead (Gals.)	Length (in.)	O.D. (in.)	No./Case
HAC-10-W	Activated Carbon	1.5	5.7	5,000	500	—	9-3/4	2-3/4	24
HAC-20-W	Activated Carbon	3	11.3	10,000	1,000	—	20	2-3/4	24
HAC-10-LR-W	AC & Lead Removal	0.75	2.8	7,000	500	4,000*	9-3/4	2-3/4	24
HAC-BB-10-W	Activated Carbon	5	18.9	20,000	1,000	—	9-3/4	4-1/2	8
HAC-BB-20-W	Activated Carbon	10	37.8	40,000	2,000	—	20	4-1/2	4

* 99% lead removal typical with low pH and alkalinity to 4,000 gals. 98% to 92% removal typical with high pH and alkalinity to 3,000 gals. Data shown above is approximate and depends on filter life relative to solids content.

Note: Test data shown above is for HAC-10-W cartridge. Results may vary depending on water chemistry and other factors.

Superior Performance

Harmsco's activated carbon cartridges outperform "canister" and "impregnated" types of cartridges due to their increased carbon content, cellulose-free construction, wet molding process and dual-stage construction. They have been tested by a certified national laboratory using test procedures described in NSF Standards 42 and 53. Test results are shown below:

Chlorine Removal

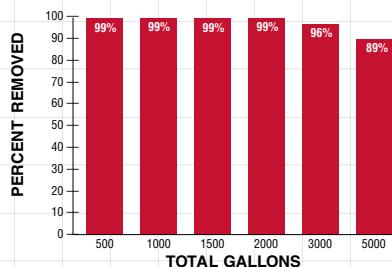

Test data generated by independent laboratory at 1 gpm using test procedures described in NSF Standard 42. Average chlorine feed at 2 ppm.

Organic Chemical Removal

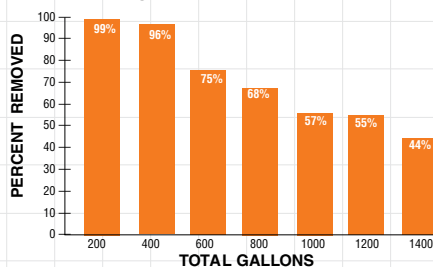

Test data generated by independent laboratory at 1 gpm using test procedures described in NSF Standard 53. TCE used as test contaminant at average feed of 300 ppb.

Lead Removal and Performance

Harmsco's HAC-10-LR-W lead removal cartridges employ the use of a specially formulated ceramic lead removal matrix plus pulverized activated carbon to reduce lead concentrations up to 99% with very short contact time. The "ATS"[™] adsorbent material works well in hard water and in the presence of iron and manganese. Performance is relatively unaffected by pH. They have been tested using the test protocol described in NSF Standard 53 and certified by an independent laboratory. The test results shown below indicate our HAC-10-LR-W lead removal cartridge will effectively reduce lead concentrations up to 99% for 4,000 gallons of low pH water and up to 92% for 3,000 gallons of high pH water.

Low pH and Alkalinity

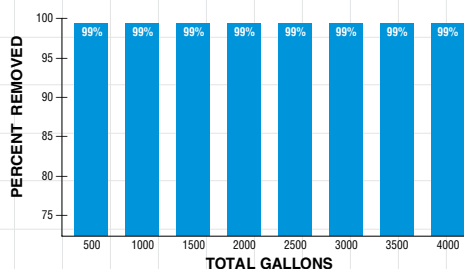

Test data generated by certified national laboratory using the protocol described in NSF Standard 53 using a flow rate of 0.75 gpm and an average feed of 150 ppb lead. Water's pH was 6.5 and alkalinity 10-30 ppm as CaCO₃.

High pH and Alkalinity

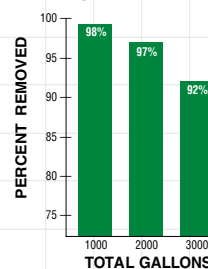

Test data generated by certified national laboratory using the protocol described in NSF Standard 53 using a flow rate of 0.75 gpm and an average feed of 150 ppb lead. Water's pH was 8.5 and alkalinity 170-250 ppm as CaCO₃.

Note: This publication is to be used as a guide. The data within has been obtained from many sources and is considered to be accurate. Harmsco does not assume liability for the accuracy and/or completeness of this data. Changes to the data can be made without notification. Temperature, Pressure, Flow Rates, Differential Pressures, Chemical Combinations and other unknown factors can affect performance in unknown ways. **Limited Warranty:** Harmsco warrants their products to be free of material and workmanship defects. Determination of suitability of Harmsco products for uses and applications contemplated by Buyer shall be the sole responsibility of Buyer. The end user/installer/buyer shall be liable for the product's performance and suitability regarding their specific intended applications. End users should perform their own tests to determine suitability for each application.



HARMSCO® Filtration Products

P.O. Box 14066, North Palm Beach, FL 33408

(561) 848-9628 • Toll-free: (800) 327-3248 • Fax: (561) 845-2474 • E-mail: sales@harmsco.com

www.harmsco.com



Made in USA

© Harmsco, Inc. 33C 10 1/12

HARMSCO®

WaterBetter® Carbon Block Cartridges

Coconut Shell Carbon

High Chlorine Reduction

Carbon block cartridges for taste, odor and chlorine reduction



COMPONENT

Models are tested and Certified by NSF International against NSF/ANSI Standard 42 for materials requirements only

- High chlorine reduction
- No channeling or bypass
- Low initial pressure drop
- Excellent contaminant reduction
- No release of carbon fines
- High dirt holding capacity
- Long cartridge life

Features

- ▶ 100% coconut shell carbon
- ▶ Radial flow design
- ▶ 10 micron filtration
- ▶ FDA approved components
- ▶ Made with unique binders
- ▶ High porosity design
- ▶ Available in a variety of sizes and flow rates



Applications

- ▶ Drinking Water
- ▶ Marine/Aquatic Filtration
- ▶ Food & Beverage Filtration
- ▶ Industrial Water Filtration
- ▶ Reverse Osmosis Pre-filtration
- ▶ Point of Entry Residential Filtration
- ▶ Point of Use Residential Filtration
- ▶ Water Bottling Filtration
- ▶ Science/Laboratory
- ▶ Photo Chemical Plating Solutions



HARMSCO® Filtration Products



WaterBetter® Carbon Block Cartridges

Specifications

- ▶ **Carbon:** coconut shell PAC
- ▶ **End caps:** Polypropylene
- ▶ **Inner/Outer Wraps:** Polypropylene
- ▶ **Nettings:** Polyethylene
- ▶ **Gaskets:** NBR
- ▶ **Temperature Rating:** 40°F (4°C) to 180°F (82°C)

Performance - Performance claims are based on independent lab results and manufacturer's internal test data. Actual performance is dependent on influent water quality, flow rates, system design and applications. Your results may vary. Performance data has not been tested or validated by NSF.

Micron Ratings - Micron ratings are based on 85% or greater removal of the stated nominal micron rating.

Capacity - Estimated capacity based on using 2 ppm free chlorine with greater than 90% reduction.

Cartridges (new) - Flush new cartridges until water runs clear prior to use.



COMPONENT

Models are tested and Certified by NSF International against NSF/ANSI Standard 42 for materials requirements only

Cartridge Selection/Sizing Guide

2-3/4" and 4-1/2" O.D.

Product Code	Nominal Micron Rating	Chlorine, Taste, Odor Reduction Capacity @ Flow (GPM)	Chlorine, Taste, Odor Reduction Capacity @ Flow (LPM)	Initial Pressure Drop (psi) @ Flow Rate (gpm)	Initial Pressure Drop (bar) @ Flow Rate (lpm)	Length (in)	O.D. (in)
WBCB-975	10	> 8,000 gallons @ 1 gpm	> 30,000 liters @ 3.8 lpm	2.6 psi @ 1 gpm	.18 bar @ 3.8 lpm	9-3/4	2-3/4
WBCB-20	10	> 16,000 gallons @ 2 gpm	> 60,000 liters @ 7.6 lpm	2.6 psi @ 2 gpm	.18 bar @ 7.6 lpm	20	2-3/4
WBCB-BB-975	10	> 16,000 gallons @ 3 gpm	> 60,000 liters @ 11.4 lpm	4.0 psi @ 3 gpm	.28 bar @ 11.4 lpm	9-3/4	4-1/2
WBCB-BB-20	10	> 34,000 gallons @ 7 gpm	> 129,000 liters @ 26.5 lpm	6.0 psi @ 7 gpm	.41 bar @ 26.6 lpm	20	4-1/2

Warning - Do not use with water that is microbiologically unsafe or of unknown quality without adequate disinfection before or after the system.

WaterBetter® Carbon Block Cartridges

Filtration is made easy combining WaterBetter® carbon block cartridges with Harmsco's HIF, WB and FSSS filter housings.



Note: This publication is to be used as a guide. The data within has been obtained from many sources and is considered to be accurate. Harmsco does not assume liability for the accuracy and/or completeness of this data. Changes to the data can be made without notification. Temperature, Pressure, Flow Rates, Differential Pressures, Chemical Combinations and other unknown factors can affect performance in unknown ways. **Limited Warranty:** Harmsco warrants their products to be free of material and workmanship defects. Determination of suitability of Harmsco products for uses and applications contemplated by Buyer shall be the sole responsibility of Buyer. The end user/installer/buyer shall be liable for the product's performance and suitability regarding their specific intended applications. End users should perform their own tests to determine suitability for each application.



HARMSCO® Filtration Products

P.O. Box 14066, North Palm Beach, FL 33408

(561) 848-9628 • Toll-free: (800) 327-3248 • Fax: (561) 845-2474 • E-mail: sales@harmsco.com

www.harmsco.com



© Harmsco, Inc. 33D 09 7/11

HARMSCO®

Premium Hurricane® Carbon Cartridges

DBP Tested

Designed for Hurricane® and WaterBetter® filter housings.

Activated Carbon cartridges for Hurricane® and WaterBetter® filter housings - featuring 5 micron nominal pre-filtration. The industry's largest carbon block cartridge.

- High chlorine removal
- High THMs removal
- Longer filter runs for fewer change-outs
- Lower initial pressure drops
- Reduced maintenance down time and cost
- Increased contaminant removal
- taste, odors, DBPs
- Easy to install and clean

Features

- ▶ High performance extruded activated carbon block technology
- ▶ Integrated 5 micron pleated pre-filter for extended life
- ▶ Three sizes for greater media surface area
- ▶ Low initial pressure drop compared to granular activated carbon (no channeling)
- ▶ Patented Dual Durometer end caps to ensure better sealing
- ▶ Engineered media for superior performance
- ▶ Cleanable and reusable in most applications
- ▶ DBP Tested



Cut-away view



Applications

- ▶ Commercial/Residential Drinking Water Filtration
- ▶ Reverse Osmosis Pre-filtration
- ▶ Water Bottling Filtration
- ▶ Point of entry for the dwelling
- ▶ Industrial Waste Water Treatment
- ▶ Environmental Filtration
- ▶ Industrial/Commercial Process Water



HARMSCO® Filtration Products



Made in USA

Premium Hurricane® Carbon Cartridges

Specifications

- ▶ **Carbon:** high performance extruded activated carbon block
- ▶ **Outer layer:** 5 micron nominal pleated Polyester-Plus™ media
- ▶ **Center tubes:** PVC, rigid and perforated
- ▶ **End caps:** Plastisol (pliable PVC) Dual Durometer
- ▶ **Directional flow:** radial (outside to in) for low pressure drop
- ▶ **Temperature:** rated to 125°F (52°C)

Cartridge Selection/Sizing Guide

40 90 170

7-3/4" O.D. Hurricane® Carbon Cartridges

Cartridge Length

9-5/8"
19-1/2"
30-3/4"

Product Code	Nominal Micron Rating	Media (sq.ft.)	Recommended Flow Rate (GPM)	Min. Carbon Content** (lbs)	Capacity**	Chlorine Reduction*	THMs Reduction
HC/40-AC-5	5	25	5	3	90,000 gals	90-95% at 5 gpm	95-98% at 5 gpm
HC/90-AC-5	5	55	10	6.25	180,000 gals	90-95% at 10 gpm	95-98% at 10 gpm
HC/170-AC-5	5	90	15	10	270,000 gals	90-95% at 15 gpm	95-98% at 15 gpm

Not recommended for drinking water applications where water is not micro-biologically safe.

*Results may vary and are based on flow and other factors. **Approximate.

Note: As with any fluid application involving carbon media, "slower is better." As a result, Harmsco, Inc. recommends limiting flow rates to allow for effective contact time. The above listed data, based on 2 PPM chlorine feed, indicates potential chlorine reduction for a volume of chlorinated water at given flow rates.



Performance of carbon block core validated by the U.S. EPA

Each cartridge individually shrink wrapped and boxed for protection.

High carbon content for extended performance. Outer layer of pleated 5 micron Polyester-Plus™ filter media to protect the carbon by removing sediment and extend filter life.

Pressure Drop

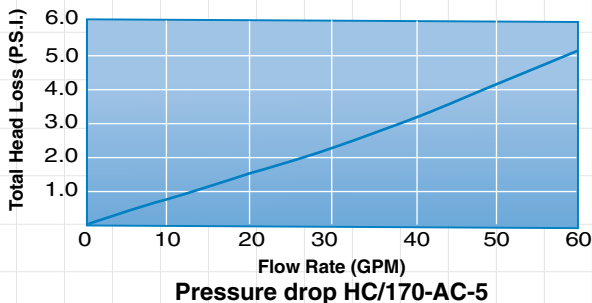

Dual Durometer End Cap

Plastisol

Carbon

5 Micron Media



Cut-away view

Note: This publication is to be used as a guide. The data within has been obtained from many sources and is considered to be accurate. Harmsco does not assume liability for the accuracy and/or completeness of this data. Changes to the data can be made without notification. Temperature, Pressure, Flow Rates, Differential Pressures, Chemical Combinations and other unknown factors can affect performance in unknown ways. **Limited Warranty:** Harmsco warrants their products to be free of material and workmanship defects. Determination of suitability of Harmsco products for uses and applications contemplated by Buyer shall be the sole responsibility of Buyer. The end user/installer/buyer shall be liable for the product's performance and suitability regarding their specific intended applications. End users should perform their own tests to determine suitability for each application.



HARMSCO® Filtration Products

P.O. Box 14066, North Palm Beach, FL 33408

(561) 848-9628 • Toll-free: (800) 327-3248 • Fax: (561) 845-2474 • E-mail: sales@harmsco.com

www.harmsco.com



Made in USA

© Harmsco, Inc. 33A 21 7/11

All-Poly Absolute Rated

99.98 Efficiency (Beta 5000)

Pleated Polypropylene Cartridges

Harmsco® High Purity Pleated Cartridges are manufactured for use in most applications where absolute rated filtration is needed.

- Long service life
- High flow rates
- Low pressure drop
- High permeability

Features

- ▶ 100% polypropylene; nothing to leach/contaminate
- ▶ High efficiency for critical filtration applications
- ▶ Pleated design for extended surface area
- ▶ Polypropylene end cap, thermally welded to media, cage and core
- ▶ USP Class VI - 121°C (250°F) for plastics
- ▶ 6.5 square feet of filtration media per 9-3/4" cartridge
- ▶ Offered in multiple lengths and end cap configurations to fit in competitive filter housings
- ▶ FDA Listed Materials: Manufactured from materials which are listed for food contact applications in Title 21 of the U.S. Code of Federal Regulations



Pleated Polypropylene Cartridges

Applications

- ▶ Food & Beverage
- ▶ Cosmetics
- ▶ Photographic Solutions
- ▶ Reagent and Electronic Grade Chemicals
- ▶ Bottled Water
- ▶ Prefiltration Prior To Membrane Filters
- ▶ DI and RO Feedwater Prefiltration
- ▶ Magnetic Media Chemicals
- ▶ Process Water
- ▶ Fine Chemicals
- ▶ Plating Chemicals
- ▶ Wastewater
- ▶ Pharmaceuticals and Biologicals
- ▶ Ophthalmics



Specifications

Construction Materials

Filtration Media Polypropylene
Support Media Polypropylene
End Caps Polypropylene
Center Core Polypropylene
Outer Support Cage Polypropylene
O-rings/Gaskets Buna, Viton, EPDM, Silicone, Teflon® Encapsulated Viton

Toxicity

All polypropylene components meet the specifications for biological safety per USP Class VI: 250°F (121°C) for plastics.

Dimensions

Length: 10 to 40 inches (25.4 to 101.6 cm) nominal
Outside Diameter: 2.7 inches (7.0 cm) nominal

Media Surface Area

6.5 square feet per 9-3/4" length

Maximum Recommended Operating Conditions

Change Out ΔP 35 PSI
Temperature 180°F (82°C)

FDA Listed Materials

Manufactured from materials which are listed for food contact applications in Title 21 of the U.S. Code of Federal Regulations.

Sanitization/Sterilization

Filtered Hot Water 194°F (90°C)

Chemical Sanitization - Industry standard concentrations of hydrogen peroxide, peracetic acid, sodium hypochlorite and other selected chemicals.

Cartridge Selection/Sizing Guide

Packed 6 per case, with cartridges individually bagged and cartoned.

✓ Model	✓ Length	✓ Micron Size	✓ End Cap Code	✓ O-Rings/Gaskets	✓ Adders
PP	975 (9-3/4")	0.2	DOE (double open end)	E (EPDM)*	I (stainless steel insert)
	195 (19-1/2")	0.45	213 (internal o-ring)	B (Buna)	HP (heavy poly core)
	20 (20")	1	222 (flat cap)	S (Silicone)	
	2925 (29-1/4")	5	222-F (fin)	V (Viton)	
	30 (30")		222-S (spring)	T (Teflon Encapsulated Viton)	
	40 (40")		226 (flat cap)		
			226-F (fin)		
			226-S (spring)		

Example: PP - 195 - 0.2 - 222-F - E

*EPDM is standard for all o-rings and gaskets, unless otherwise noted.

Flow Rate

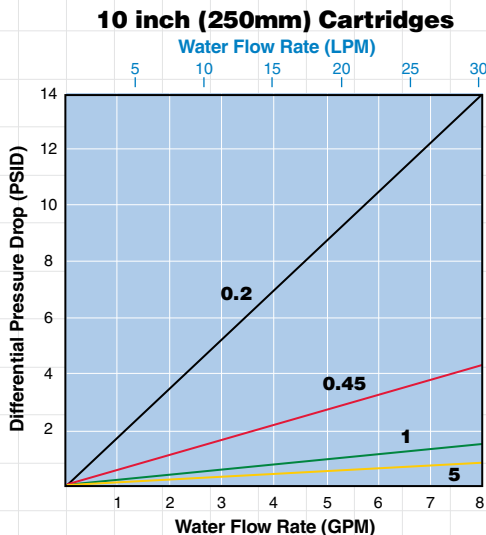

Cartridge End Cap Configurations



Note: This publication is to be used as a guide. The data within has been obtained from many sources and is considered to be accurate. Harmsco does not assume liability for the accuracy and/or completeness of this data. Changes to the data can be made without notification. Temperature, Pressure, Flow Rates, Differential Pressures, Chemical Combinations and other unknown factors can affect performance in unknown ways. **Limited Warranty:** Harmsco warrants their products to be free of material and workmanship defects. Determination of suitability of Harmsco products for uses and applications contemplated by Buyer shall be the sole responsibility of Buyer. The end user/installer/buyer shall be liable for the product's performance and suitability regarding their specific intended applications. End users should perform their own tests to determine suitability for each application.



HARMSCO® Filtration Products

P.O. Box 14066, North Palm Beach, FL 33408

(561) 848-9628 • Toll-free: (800) 327-3248 • Fax: (561) 845-2474 • E-mail: sales@harmsco.com

www.harmsco.com



Made in USA

© Harmsco, Inc. 42B 13 7/11

All-Poly Absolute Rated Water Service Grade

Absolute Rated

Hydrophilic Polyethersulfone Membrane Cartridges

Harmsco® High Purity Pleated Cartridges are manufactured for use in most applications where absolute rated filtration is needed.

- Long service life
- High flow rates
- Low pressure drop
- High permeability

Features

- ▶ 100% polypropylene; nothing to leach/contaminate
- ▶ High efficiency for critical filtration applications
- ▶ Pleated design for extended surface area
- ▶ Polypropylene end cap, thermally welded to media, cage and core
- ▶ USP Class VI - 121°C (250°F) for plastics
- ▶ 5.5 square feet of filtration media per 9-3/4" cartridge
- ▶ Offered in multiple lengths and end cap configurations to fit in competitive filter housings
- ▶ FDA Listed Materials: Manufactured from materials which are listed for food contact applications in Title 21 of the U.S. Code of Federal Regulations



Pleated Hydrophilic Polyethersulfone Membrane Cartridges

Applications

- ▶ Deionized Water Systems
- ▶ General-use Water Filtration
- ▶ Liquid Clarification
- ▶ Cosmetics
- ▶ Recirculating Fluids
- ▶ Chemical Filtration
- ▶ Pharmaceutical
- ▶ Final Filtration of Solvents, Acids, Bases



Specifications

- ▶ **Construction Materials**
 Membrane..... Polyethersulfone (PES)
 Support Media Polypropylene
 End Caps Polypropylene
 Center Core Polypropylene
 Outer Support Cage Polypropylene
 O-rings/Gaskets Buna, Viton, EPDM, Silicone, Teflon® Encapsulated Viton
- ▶ **Toxicity**
 All polypropylene components meet the specifications for biological safety per USP Class VI: 250°F (121°C) for plastics.
- ▶ **Dimensions**
 Length: 10 to 40 inches (25.4 to 101.6 cm) nominal
 Outside Diameter: 2.7 inches (7.0 cm) nominal
- ▶ **Media Surface Area**
 5.5 square feet per 9-3/4" length

- ▶ **Maximum Recommended Operating Conditions**
 Temperature 176°F (80°C)
- ▶ **Maximum Differential Pressures**
 Forward 50 psi (3.4 bar) at 68°F (20°C)
 Reverse 40 psi (2.7 bar) at 68°F (20°C)
- ▶ **FDA Listed Materials**
 Manufactured from materials which are listed for food contact applications in Title 21 of the U.S. Code of Federal Regulations.
- ▶ **Sanitization**
 Filtered Hot Water 190°F (88°C) for 30 minutes at a maximum of 15 psid. Cartridges are chemically compatible with most ultra-pure chemicals, solvents and sanitizing agents.

Cartridge Selection/Sizing Guide

Packed 6 per case, with cartridges individually bagged and cartoned.

✓ Model	✓ Length	✓ Micron Size	✓ End Cap Code	✓ O-Rings/Gaskets	✓ Adders
PES	975 (9-3/4")	0.1	DOE (double open end)	E (EPDM)*	I (stainless steel insert)
	195 (19-1/2")	0.2	213 (internal o-ring)	B (Buna)	HP (heavy poly core)
	20 (20")	0.45	222 (flat cap)	S (Silicone)	
	2925 (29-1/4")	0.65	222-F (fin)	V (Viton)	
	30 (30")	0.8	226 (flat cap)	T (Teflon Encapsulated Viton)	
	40 (40")		226-F (fin)		

Example: PES – 195 – 0.2 – 222-F – E

*EPDM is standard for all o-rings and gaskets, unless otherwise noted.

Flow Rate

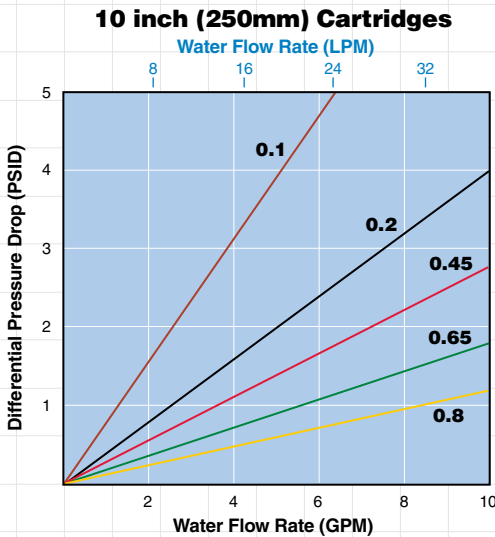

Cartridge End Cap Configurations



Note: This publication is to be used as a guide. The data within has been obtained from many sources and is considered to be accurate. Harmsco does not assume liability for the accuracy and/or completeness of this data. Changes to the data can be made without notification. Temperature, Pressure, Flow Rates, Differential Pressures, Chemical Combinations and other unknown factors can affect performance in unknown ways. **Limited Warranty:** Harmsco warrants their products to be free of material and workmanship defects. Determination of suitability of Harmsco products for uses and applications contemplated by Buyer shall be the sole responsibility of Buyer. The end user/installer/buyer shall be liable for the product's performance and suitability regarding their specific intended applications. End users should perform their own tests to determine suitability for each application.



HARMSCO® Filtration Products

P.O. Box 14066, North Palm Beach, FL 33408
 (561) 848-9628 • Toll-free: (800) 327-3248 • Fax: (561) 845-2474 • E-mail: sales@harmsco.com

www.harmsco.com



Made in USA

© Harmsco, Inc. 42A 08 7/11

All-Poly Absolute Rated Food & Beverage Grade

Absolute Rated

Hydrophilic Polyethersulfone Membrane Cartridges

Harmsco® High Purity Pleated Cartridges are manufactured for use in most applications where absolute rated filtration is needed.

- Long service life
- High flow rates
- Low pressure drop
- High permeability

Features

- ▶ 100% polypropylene; nothing to leach/contaminate
- ▶ High efficiency for critical filtration applications
- ▶ Pleated design for extended surface area
- ▶ Polypropylene end cap, thermally welded to media, cage and core
- ▶ USP Class VI - 121°C (250°F) for plastics
- ▶ 8.5 square feet of filtration media per 9-3/4" cartridge
- ▶ Offered in multiple lengths and end cap configurations to fit in competitive filter housings
- ▶ FDA Listed Materials: Manufactured from materials which are listed for food contact applications in Title 21 of the U.S. Code of Federal Regulations



Pleated Hydrophilic Polyethersulfone Membrane Cartridges

Applications

- ▶ Wine
- ▶ Beer
- ▶ Juices
- ▶ R/O Pre-filtration
- ▶ Soft Drinks
- ▶ Bottled Water
- ▶ Distilled Water
- ▶ Chemicals



Specifications

Construction Materials

Membrane..... Polyethersulfone (PES)
 Support Media Polypropylene
 End Caps Polypropylene
 Center Core Polypropylene
 Outer Support Cage Polypropylene
 O-rings/Gaskets Buna, Viton, EPDM, Silicone, Teflon® Encapsulated Viton

Toxicity

All polypropylene components meet the specifications for biological safety per USP Class VI: 250°F (121°C) for plastics.

Dimensions

Length: 10 to 40 inches (25.4 to 101.6 cm) nominal
Outside Diameter: 2.7 inches (7.0 cm) nominal

Media Surface Area

8.5 square feet per 9-3/4" length

Maximum Recommended Operating Conditions

Temperature 176°F (80°C)

Maximum Differential Pressures

Forward 50 psi (3.4 bar) at 68°F (20°C)
Reverse 40 psi (2.7 bar) at 68°F (20°C)

FDA Listed Materials

Manufactured from materials which are listed for food contact applications in Title 21 of the U.S. Code of Federal Regulations.

Sanitization/Sterilization

Filtered Hot Water 190°F (88°C) for 30 minutes
Steam Sterilization*: 250°F (121°C) for 30 minutes, multiple cycles

Chemicals: cartridges are chemically compatible with most chemicals and sanitizing agents

***Note:** stainless insert option needed for all cartridges being hot water sanitized or steam sterilized.

Cartridge Selection/Sizing Guide

Packed 6 per case, with cartridges individually bagged and cartoned.

✓ Model	✓ Length	✓ Micron Size	✓ End Cap Code	✓ O-Rings/Gaskets	✓ Adders
PES FB	975 (9-3/4")	0.04	DOE (double open end)	E (EPDM)*	I (stainless steel insert)
	195 (19-1/2")	0.1	213 (internal o-ring)	B (Buna)	HP (heavy poly core)
	20 (20")	0.2	222 (flat cap)	S (Silicone)	
	2925 (29-1/4")	0.45	222-F (fin)	V (Viton)	
	30 (30")	0.65	226 (flat cap)	T (Teflon Encapsulated Viton)	
	40 (40")	0.8	226-F (fin)		

Example: PES FB – 195 – 0.2 – 222-F – E

*EPDM is standard for all o-rings and gaskets, unless otherwise noted.

Flow Rate

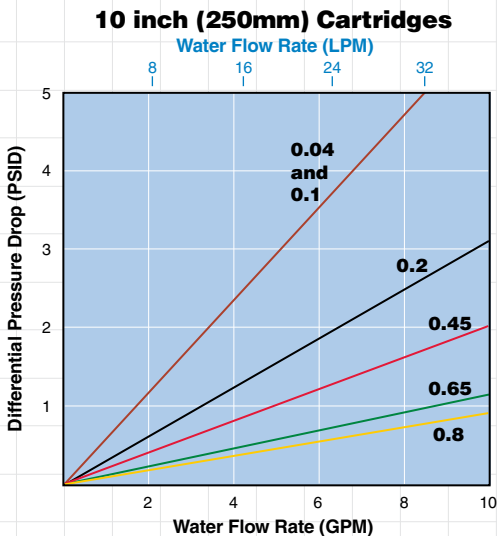

Cartridge End Cap Configurations



Note: This publication is to be used as a guide. The data within has been obtained from many sources and is considered to be accurate. Harmsco does not assume liability for the accuracy and/or completeness of this data. Changes to the data can be made without notification. Temperature, Pressure, Flow Rates, Differential Pressures, Chemical Combinations and other unknown factors can affect performance in unknown ways. **Limited Warranty:** Harmsco warrants their products to be free of material and workmanship defects. Determination of suitability of Harmsco products for uses and applications contemplated by Buyer shall be the sole responsibility of Buyer. The end user/installer/buyer shall be liable for the product's performance and suitability regarding their specific intended applications. End users should perform their own tests to determine suitability for each application.



HARMSCO® Filtration Products

P.O. Box 14066, North Palm Beach, FL 33408

(561) 848-9628 • Toll-free: (800) 327-3248 • Fax: (561) 845-2474 • E-mail: sales@harmsco.com

www.harmsco.com



Made in USA

© Harmsco, Inc. 42D 07 7/11

All-Poly Absolute Rated

Hydrophilic Polysulfone

Pleated Polysulfone Membrane Cartridges

Harmsco® High Purity Pleated Cartridges are manufactured for use in most applications where absolute rated filtration is needed.

- Long service life
- High flow rates
- Low pressure drop
- High permeability

Features

- ▶ Hydrophilic polysulfone membrane
- ▶ Absolute rated pore sizes from 0.05 to 0.80 microns
- ▶ Thermal bonded polypropylene support structure
- ▶ Excellent flow vs. pressure drop
- ▶ 6 square feet of filtration media per 9-3/4" cartridge
- ▶ Extremely fast rinse-up times
- ▶ FDA Listed Materials for potable water/liquid foods
- ▶ USP Class VI - 121°C (250°F) Polysulfone (PS) Membrane for Plastics

Applications

- ▶ Food & Beverage
- ▶ Cosmetics
- ▶ Photographic Solutions
- ▶ Reagent and Electronic Grade Chemicals
- ▶ Bottled Water
- ▶ Prefiltration Prior To Membrane Filters
- ▶ DI and RO Feedwater Prefiltration
- ▶ Magnetic Media Chemicals
- ▶ Process Water

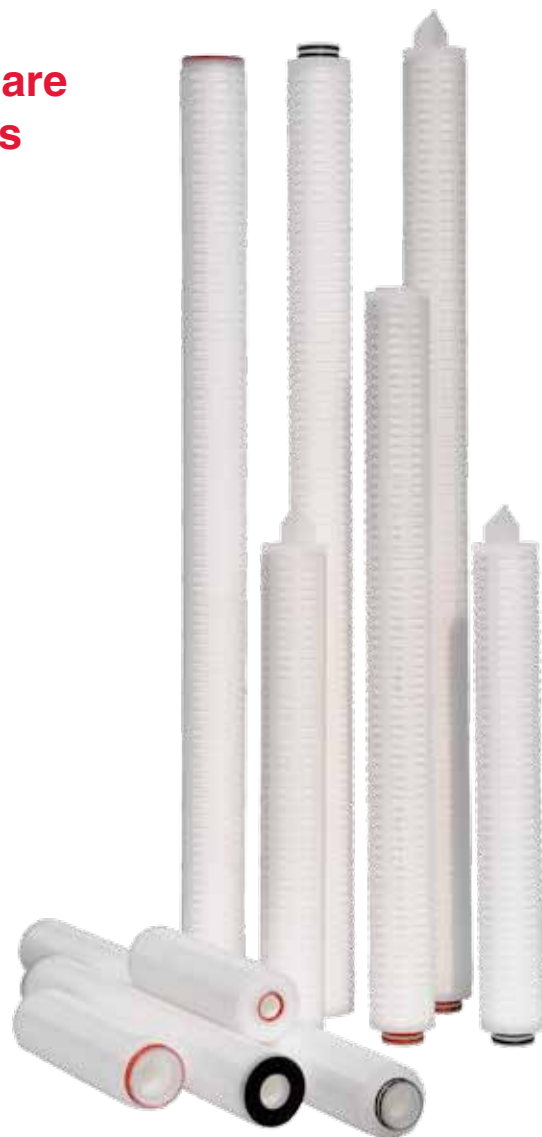

Pleated Hydrophilic Polysulfone Membrane Cartridges

- ▶ Fine Chemicals
- ▶ Plating Chemicals
- ▶ Wastewater
- ▶ Pharmaceuticals and Biologicals
- ▶ Ophthalmics



Specifications

Construction Materials

Membrane.....Polysulfone (PS)
 Support MediaPolypropylene
 End CapsPolypropylene
 Center CorePolypropylene
 Outer Support CagePolypropylene
 O-rings/Gaskets.....Buna, Viton, EPDM,
 Silicone, Teflon® Encapsulated Viton

Toxicity

All polypropylene components meet the specifications for biological safety per USP Class VI: 250°F (121°C) for plastics.

Dimensions

Length: 10 to 40 inches (25.4 to 101.6 cm) nominal
Outside Diameter: 2.7 inches (7.0 cm) nominal

Media Surface Area

6 square feet per 9-3/4" length

Max. Recommended Operating Conditions

Temperature176°F (80°C)

Maximum Differential Pressures

Forward50 psi (3.4 bar) at 68°F (20°C)
Reverse.....40 psi (2.7 bar) at 68°F (20°C)

FDA Listed Materials

Manufactured from materials which are listed for food contact applications in Title 21 of the U.S. Code of Federal Regulations.

Sanitization/Sterilization

Filtered Hot Water176°F (80°C) for 30 minutes
Steam Sterilization250°F (121°C) for 30 minutes, multiple cycles.

Chemicals: cartridges are chemically compatible with most chemicals and sanitizing agents.

Note: stainless steel insert option needed for all cartridges being hot water sanitized or steam sterilized.

Cartridge Selection/Sizing Guide

Packed 6 per case, with cartridges individually bagged and cartoned.

✓ Model	✓ Length	✓ Micron Size	✓ End Cap Code	✓ O-Rings/Gaskets	✓ Adders
PS	975 (9-3/4")	0.05	DOE (double open end)	E (EPDM)*	I (stainless steel insert)
	195 (19-1/2")	0.1	213 (internal o-ring)	B (Buna)	HP (heavy poly core)
	20 (20")	0.2	222 (flat cap)	S (Silicone)	R (18 megohm rinse)
	2925 (29-1/4")	0.45	222-F (fin)	V (Viton)	
	30 (30")	0.65	226 (flat cap)	T (Teflon Encapsulated Viton)	
	40 (40")	0.8	226-F (fin)		

Example: PS – 20 – 0.2 – 222-F – E

*EPDM is standard for all o-rings and gaskets, unless otherwise noted.

Flow Rate

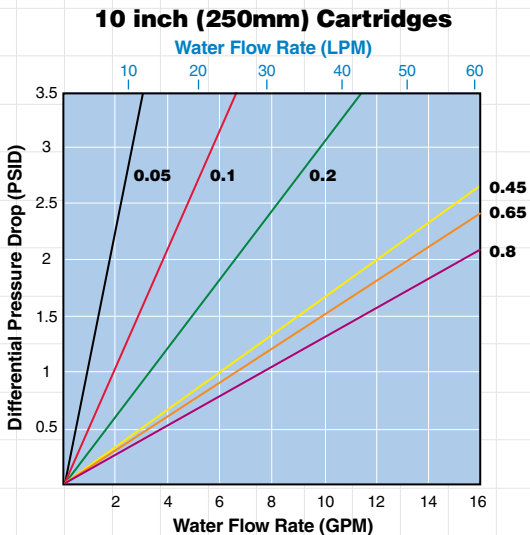

Cartridge End Cap Configurations



Note: This publication is to be used as a guide. The data within has been obtained from many sources and is considered to be accurate. Harmsco does not assume liability for the accuracy and/or completeness of this data. Changes to the data can be made without notification. Temperature, Pressure, Flow Rates, Differential Pressures, Chemical Combinations and other unknown factors can affect performance in unknown ways. **Limited Warranty:** Harmsco warrants their products to be free of material and workmanship defects. Determination of suitability of Harmsco products for uses and applications contemplated by Buyer shall be the sole responsibility of Buyer. The end user/installer/buyer shall be liable for the product's performance and suitability regarding their specific intended applications. End users should perform their own tests to determine suitability for each application.



HARMSCO® Filtration Products

P.O. Box 14066, North Palm Beach, FL 33408

(561) 848-9628 • Toll-free: (800) 327-3248 • Fax: (561) 845-2474 • E-mail: sales@harmsco.com

www.harmsco.com



Made in USA

© Harmsco, Inc. 42G 06 7/11

All-Poly High Purity

99.98 Efficiency (Beta 5000)

Pleated Microfiberglass Cartridges

Harmsco® High Purity Pleated Cartridges are manufactured for use in most applications where absolute rated filtration is needed.

- Long service life
- High flow rates
- Low pressure drop
- High permeability

Features

- ▶ High efficiency for critical filtration applications
- ▶ Pleated design for extended surface area
- ▶ Polypropylene end cap, thermally welded to media, cage and core
- ▶ FDA Listed Materials for potable water/liquid foods
- ▶ USP Class VI - 121°C (250°F) for plastics
- ▶ 6 square feet of filtration media per 9-3/4" cartridge
- ▶ Offered in multiple lengths and end cap configurations to fit in competitive filter housings
- ▶ Positive charged media



Microfiberglass Cartridges

Applications

- ▶ Sterile Air
- ▶ Cosmetics
- ▶ Photographic Solutions
- ▶ Reagent and Electronic Grade Chemicals
- ▶ Wine Clarification
- ▶ Prefiltration Prior To Membrane Filters
- ▶ DI and RO Feedwater Prefiltration
- ▶ Hydrocarbons
- ▶ Process Water
- ▶ Fine Chemicals
- ▶ Plating Chemicals
- ▶ Wastewater
- ▶ Pharmaceuticals and Biologicals
- ▶ Ophthalmics



Specifications

Construction Materials

Filtration Media.....FDA borosilicate microfiberglass with acrylic binder
Support Media.....Spun-bonded polyester laminated on both upstream and downstream sides
End Caps.....Polypropylene
Center Core.....Fiberglass
Outer Support Cage.....Polypropylene
O-rings/Gaskets.....Buna, Viton, EPDM, Silicone, Teflon® Encapsulated Viton

Dimensions

Length: 10 to 40 inches (25.4 to 101.6 cm) nominal
Outside Diameter: 2.7 inches (7.0 cm) nominal

Toxicity

All polypropylene components meet the specifications for biological safety per USP Class VI: 250°F (121°C) for plastics.

Media Surface Area

6 square feet per 9-3/4" length

Max. Recommended Operating Conditions

Change Out.....ΔP 35 PSI; **Temperature**.....200°F (93°C)

FDA Listed Materials

Manufactured from materials which are listed for food contact applications in Title 21 of the U.S. Code of Federal Regulations.

Sanitization/Sterilization

Filtered Hot Water176°F (80°C) for 30 minutes
Steam Sterilization250°F (121°C) for 30 minutes, multiple cycles.

Chemicals: cartridges are chemically compatible with most chemicals and sanitizing agents.

Note: stainless steel insert option needed for all cartridges being hot water sanitized or steam sterilized.

Cartridge Selection/Sizing Guide

Packed 6 per case, with cartridges individually bagged and cartoned.

✓ Model	✓ Length	✓ Micron Size	✓ End Cap Code	✓ O-Rings/Gaskets	✓ Adders
FG	975 (9-3/4")	0.45	DOE (double open end)	E (EPDM)*	I (stainless steel insert)
	195 (19-1/2")	1	213 (internal o-ring)	B (Buna)	HP (heavy poly core)
	20 (20")	2	222 (flat cap)	S (Silicone)	
	2925 (29-1/4")	5	222-F (fin)	V (Viton)	
	30 (30")	10	222-S (spring)	T (Teflon Encapsulated Viton)	
	40 (40")	20	226 (flat cap)		
		40	226-F (fin)		
			226-S (spring)		

Example: FG – 195 – 0.45 – 222-F – E

*EPDM is standard for all o-rings and gaskets, unless otherwise noted.

Flow Rate

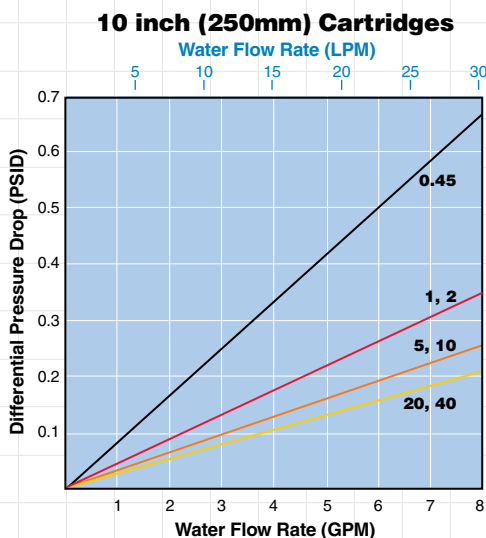

Cartridge End Cap Configurations



Fin Flat Cap 226 (w/SS insert)



226 222 (w/SS insert) 222 Flat Cap



213 (internal o-ring) PP Core Ext. Spring DOE (double open end)

Note: This publication is to be used as a guide. The data within has been obtained from many sources and is considered to be accurate. Harmsco does not assume liability for the accuracy and/or completeness of this data. Changes to the data can be made without notification. Temperature, Pressure, Flow Rates, Differential Pressures, Chemical Combinations and other unknown factors can affect performance in unknown ways. **Limited Warranty:** Harmsco warrants their products to be free of material and workmanship defects. Determination of suitability of Harmsco products for uses and applications contemplated by Buyer shall be the sole responsibility of Buyer. The end user/installer/buyer shall be liable for the product's performance and suitability regarding their specific intended applications. End users should perform their own tests to determine suitability for each application.



HARMSCO® Filtration Products

P.O. Box 14066, North Palm Beach, FL 33408

(561) 848-9628 • Toll-free: (800) 327-3248 • Fax: (561) 845-2474 • E-mail: sales@harmsco.com

www.harmsco.com



Made in USA

© Harmsco, Inc. 42F 03 7/11

All-Poly High Purity

Hydrophobic Membrane

Pleated Teflon® Membrane Cartridges

Harmsco® High Purity Pleated Cartridges are manufactured for use in most applications where absolute rated filtration is needed.

- Long service life
- High flow rates
- Low pressure drop
- High permeability

Features

- ▶ High efficiency for critical filtration applications
- ▶ Pleated design for extended surface area
- ▶ Polypropylene end cap, thermally welded to media, cage and core
- ▶ FDA Listed Materials for potable water/liquid foods
- ▶ USP Class VI - 121°C (250°F) for plastics
- ▶ 8.5 square feet of filtration media per 9-3/4" cartridge
- ▶ Offered in multiple lengths and end cap configurations to fit in competitive filter housings



Pleated Teflon® Membrane Cartridges

Applications

- ▶ Sterile Air
- ▶ Venting
- ▶ Photographic Solutions
- ▶ Reagent and Electronic Grade Chemicals
- ▶ Prefiltration Prior To Membrane Filters
- ▶ DI and RO Feedwater Prefiltration
- ▶ Aggressive Fluids
- ▶ Process Water
- ▶ Fine Chemicals
- ▶ Plating Chemicals
- ▶ Wastewater
- ▶ Pharmaceuticals and Biologicals



Specifications

Construction Materials

Filtration Media.....Teflon® Membrane
Support Media.....Polypropylene
End Caps.....Polypropylene
Center Core.....Polypropylene
Outer Support Cage.....Polypropylene
O-rings/Gaskets.....Buna, Viton, EPDM, Silicone, Teflon® Encapsulated Viton

Dimensions

Length: 10 to 40 inches (25.4 to 101.6 cm) nominal
Outside Diameter: 2.7 inches (7.0 cm) nominal

Toxicity

All polypropylene components meet the specifications for biological safety per USP Class VI: 250°F (121°C) for plastics.

Media Surface Area

8.5 square feet per 9-3/4" length

Max. Recommended Operating Conditions

Change Out.....ΔP 35 PSI; **Temperature**.....200°F (93°C)

FDA Listed Materials

Manufactured from materials which are listed for food contact applications in Title 21 of the U.S. Code of Federal Regulations.

Sanitization/Sterilization

Filtered Hot Water176°F (80°C) for 30 minutes

Steam Sterilization250°F (121°C) for 30 minutes, multiple cycles.

Chemicals: cartridges are chemically compatible with most chemicals and sanitizing agents.

Note: stainless steel insert option needed for all cartridges being hot water sanitized or steam sterilized.

Cartridge Selection/Sizing Guide

Packed 6 per case, with cartridges individually bagged and cartoned.

✓ Model	✓ Length	✓ Micron Size	✓ End Cap Code	✓ O-Rings/Gaskets	✓ Adders
TF	975 (9-3/4")	0.1	DOE (double open end)	E (EPDM)*	I (stainless steel insert)
	195 (19-1/2")	0.2	213 (internal o-ring)	B (Buna)	HP (heavy poly core)
	20 (20")	0.45	222 (flat cap)	S (Silicone)	
	2925 (29-1/4")		222-F (fin)	V (Viton)	
	30 (30")		222-S (spring)	T (Teflon Encapsulated Viton)	
	40 (40")		226 (flat cap)		
			226-F (fin)		
			226-S (spring)		

Example: TF – 195 – 0.45 – 222-F – E

*EPDM is standard for all o-rings and gaskets, unless otherwise noted.

Flow Rate

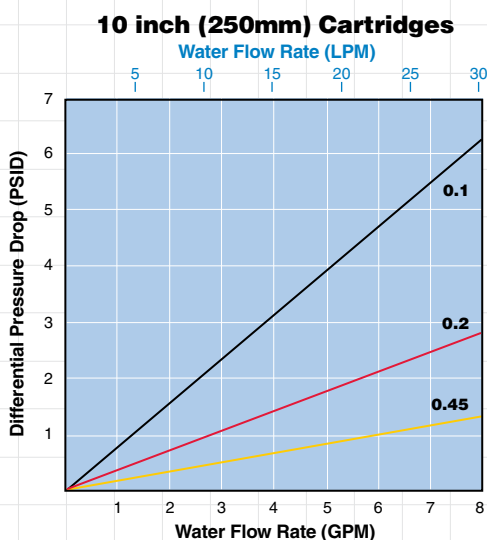

Cartridge End Cap Configurations



Note: This publication is to be used as a guide. The data within has been obtained from many sources and is considered to be accurate. Harmsco does not assume liability for the accuracy and/or completeness of this data. Changes to the data can be made without notification. Temperature, Pressure, Flow Rates, Differential Pressures, Chemical Combinations and other unknown factors can affect performance in unknown ways. **Limited Warranty:** Harmsco warrants their products to be free of material and workmanship defects. Determination of suitability of Harmsco products for uses and applications contemplated by Buyer shall be the sole responsibility of Buyer. The end user/installer/buyer shall be liable for the product's performance and suitability regarding their specific intended applications. End users should perform their own tests to determine suitability for each application.



HARMSCO® Filtration Products

P.O. Box 14066, North Palm Beach, FL 33408

(561) 848-9628 • Toll-free: (800) 327-3248 • Fax: (561) 845-2474 • E-mail: sales@harmsco.com

www.harmsco.com



Made in USA

© Harmsco, Inc. 42E 02 7/11

All-Poly High Purity

Hydrophilic Nylon

Pleated Nylon 6,6 and Nylon Plus (+) Cartridges

Harmsco® High Purity Pleated Cartridges are manufactured for use in most applications where absolute rated filtration is needed.

- Long service life
- High flow rates
- Low pressure drop
- High permeability

Features

- ▶ High efficiency for critical filtration applications
- ▶ Pleated design for extended surface area
- ▶ Polypropylene end cap, thermally welded to media, cage and core
- ▶ FDA Listed Materials for potable water/liquid foods
- ▶ USP Class VI - 121°C (250°F) for plastics
- ▶ 8.5 square feet of filtration media per 9-3/4" cartridge
- ▶ Offered in multiple lengths and end cap configurations to fit in competitive filter housings
- ▶ Nylon Plus + Grade offers high positive charge for removal of endotoxins and small negatively charged contaminants

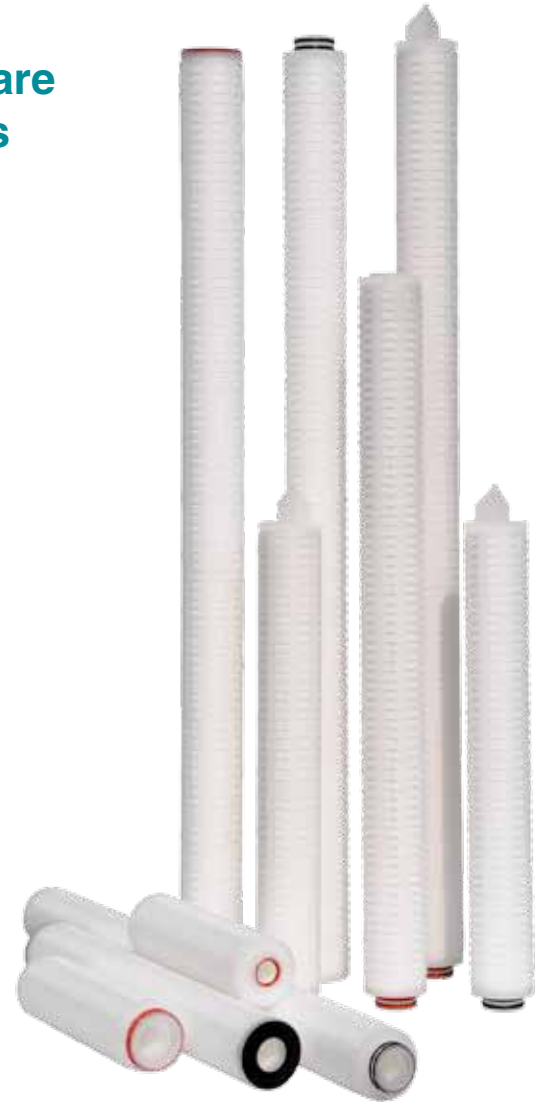

Pleated Nylon 6,6 Cartridges

Applications

- ▶ Endotoxin Removal (NY P)
- ▶ Cosmetics
- ▶ Photographic Solutions
- ▶ Reagent and Electronic Grade Chemicals
- ▶ Bottled Water
- ▶ Prefiltration Prior To Membrane Filters
- ▶ DI and RO Feedwater Prefiltration
- ▶ Magnetic Media Chemicals
- ▶ Process Water
- ▶ Fine Chemicals
- ▶ Plating Chemicals
- ▶ Fermentation
- ▶ Pharmaceuticals and Biologicals
- ▶ Wine



Specifications

Construction Materials

Filtration Media Nylon 6,6
Support Media Polypropylene
End Caps Polypropylene
Center Core Polypropylene
Outer Support Cage Polypropylene
O-rings/Gaskets Buna, Viton, EPDM, Silicone, Teflon® Encapsulated Viton

Toxicity

All polypropylene components meet the specifications for biological safety per USP Class VI: 250°F (121°C) for plastics.

Dimensions

Length: 10 to 40 inches (25.4 to 101.6 cm) nominal
Outside Diameter: 2.7 inches (7.0 cm) nominal

Media Surface Area

8.5 square feet per 9-3/4" length

Maximum Differential Pressures

Forward 50 psi (3.4 bar) at 68°F (20°C)
Reverse 40 psi (2.7 bar) at 68°F (20°C)

FDA Listed Materials

Manufactured from materials which are listed for food contact applications in Title 21 of the U.S. Code of Federal Regulations.

Sanitization/Sterilization

Filtered Hot Water 176°F (80°C) for 30 minutes
Steam Sterilization 250°F (121°C) for 30 minutes, multiple cycles.

Chemicals: cartridges are chemically compatible with most chemicals and sanitizing agents.

Note: stainless steel insert option needed for all cartridges being hot water sanitized or steam sterilized.

Cartridge Selection/Sizing Guide

Packed 6 per case, with cartridges individually bagged and cartoned.

✓ Model	✓ Length	✓ Micron Size	✓ End Cap Code	✓ O-Rings/Gaskets	✓ Adders
NY	975 (9-3/4")	0.1	DOE (double open end)	E (EPDM)*	I (stainless steel insert)
NY P	195 (19-1/2")	0.2	213 (internal o-ring)	B (Buna)	HP (heavy poly core)
	20 (20")	0.45	222 (flat cap)	S (Silicone)	
	2925 (29-1/4")	0.65	222-F (fin)	V (Viton)	
	30 (30")	0.8	222-S (spring)	T (Teflon Encapsulated Viton)	
	40 (40")	1.2	226 (flat cap)		
			226-F (fin)		
			226-S (spring)		

Example: NY P – 195 – 0.2 – 222-F – E (P = positive charged)

*EPDM is standard for all o-rings and gaskets, unless otherwise noted.

Flow Rate

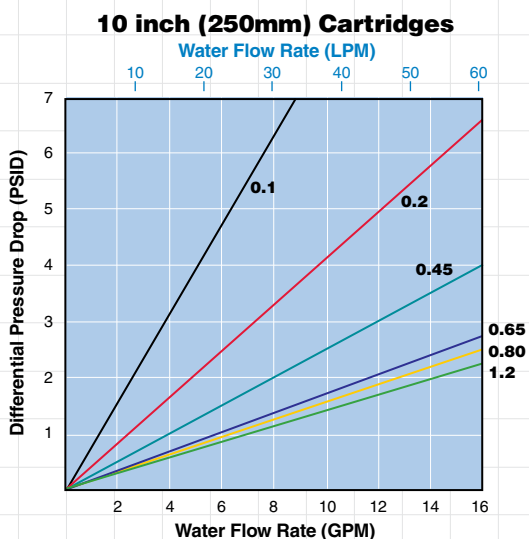

Cartridge End Cap Configurations



Note: This publication is to be used as a guide. The data within has been obtained from many sources and is considered to be accurate. Harmsco does not assume liability for the accuracy and/or completeness of this data. Changes to the data can be made without notification. Temperature, Pressure, Flow Rates, Differential Pressures, Chemical Combinations and other unknown factors can affect performance in unknown ways. **Limited Warranty:** Harmsco warrants their products to be free of material and workmanship defects. Determination of suitability of Harmsco products for uses and applications contemplated by Buyer shall be the sole responsibility of Buyer. The end user/installer/buyer shall be liable for the product's performance and suitability regarding their specific intended applications. End users should perform their own tests to determine suitability for each application.



HARMSCO® Filtration Products

P.O. Box 14066, North Palm Beach, FL 33408

(561) 848-9628 • Toll-free: (800) 327-3248 • Fax: (561) 845-2474 • E-mail: sales@harmsco.com

www.harmsco.com



Made in USA

© Harmsco, Inc. 42C 03 7/11

HARMSCO®

Premium Hurricane® High-Temp Cartridges

Industrial Grade

Designed for Hurricane® and WaterBetter® Housings

High temperature pleated cartridges for high capacity filtration. Two types of filter media for flexibility: Polyester-Plus™ and Cellulose Phenolic.

- High flow capability
 - Two types of pleated media for flexibility
 - Lower overall operating cost
 - Longer filter runs for fewer change outs
 - Increased contaminant removal
 - Two temperature ratings to choose from: 200°F (93°C) and 250°F (121°C)

Features

- ▶ Fewer cartridges for fewer change outs and lower maintenance cost
- ▶ Pleated filter media provides higher flow rates and lower initial pressure drop
- ▶ Pleated surface area provides higher loading capacity for longer filter life and increased particle removal
- ▶ Aqueous and oil based fluid applications
- ▶ High surface area (40, 90 and 170 sq. ft.) in a single cartridge design



Cellulose Phenolic
90 and 170

Polyester-Plus™
40, 90 and 170

Applications

- ▶ Hot Water Loops
- ▶ Boiler Make-up Water
- ▶ Petrochemical
- ▶ Lubricating Oil
- ▶ Cutting Fluids
- ▶ Solvents
- ▶ Distillate Fuel
- ▶ Fuel Oil
- ▶ Hydraulic Fluids
- ▶ Bio Fuels



HARMSCO® Filtration Products



Made in USA

Premium Hurricane® High-Temp Cartridges

Specifications

- ▶ **Filter media:** polyester or cellulose phenolic
- ▶ **End Caps:** injection molded (Suffix HT) or powder coated metal (Suffix HTM)
- ▶ **Temperature:** up to 200°F (93°C) w/suffix HT; up to 250°F (121°C) w/suffix HTM
- ▶ **Center Core:** powder coated perforated metal
- ▶ **pH:** 6.5 to 9.5
- ▶ **Change Out:** 25 PSI ΔP (1.7 bar)
- ▶ **O-Rings & Sealing Grommet:** Buna N standard, optional Viton available

Cartridge Selection/Sizing Guide

7-3/4" O.D. Temperature ratings based on pressure and time under load.

Cartridge Length

Product Code	Nominal Micron Rating	Media (sq ft)	Recommended Flow Rate* (GPM)	Length (in)	No./Carton
Polyester-Plus™ - rated up to 200°F (93°C)					
HC/40-20HT	20	40	35	9-5/8	1
HC/40-50HT	50	40	35	9-5/8	1
HC/90-5HT	5	90	70	19-1/2	1
HC/90-10HT	10	90	70	19-1/2	1
HC/90-20HT	20	90	70	19-1/2	1
HC/90-50HT	50	90	70	19-1/2	1
HC/170-5HT	5	170	105	30-3/4	1
HC/170-10HT	10	170	105	30-3/4	1
HC/170-20HT	20	170	105	30-3/4	1
HC/170-50HT	50	170	105	30-3/4	1

Polyester-Plus™ - rated up to 250°F (121°C)

HC/40-20HTM	20	40	35	9-5/8	1
HC/40-50HTM	50	40	35	9-5/8	1
HC/90-5HTM	5	90	70	19-1/2	1
HC/90-10HTM	10	90	70	19-1/2	1
HC/90-20HTM	20	90	70	19-1/2	1
HC/90-50HTM	50	90	70	19-1/2	1
HC/170-5HTM	5	170	105	30-3/4	1
HC/170-10HTM	10	170	105	30-3/4	1
HC/170-20HTM	20	170	105	30-3/4	1
HC/170-50HTM	50	170	105	30-3/4	1

Cellulose Phenolic - rated up to 200°F (93°C)

HC/90-5CPHT	5	90	70	19-1/2	1
HC/170-5CPHT	5	170	105	30-3/4	1

Cellulose Phenolic - rated up to 250°F (121°C)

HC/90-5CPHTM	5	90	70	19-1/2	1
HC/170-5CPHTM	5	170	105	30-3/4	1

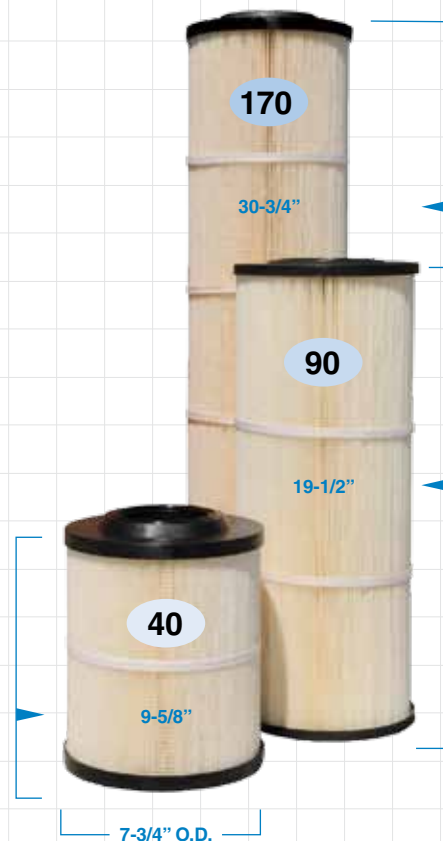

Hurricane® Cartridges
Length and O.D.

Pressure Drop

Pressure drop shown at right is for filter housing and 20 micron filter cartridge in clean water.

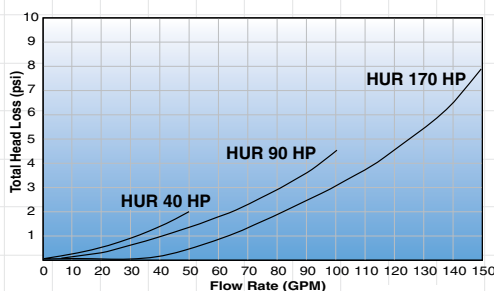

Note: This publication is to be used as a guide. The data within has been obtained from many sources and is considered to be accurate. Harmsco does not assume liability for the accuracy and/or completeness of this data. Changes to the data can be made without notification. Temperature, Pressure, Flow Rates, Differential Pressures, Chemical Combinations and other unknown factors can affect performance in unknown ways. **Limited Warranty:** Harmsco warrants their products to be free of material and workmanship defects. Determination of suitability of Harmsco products for uses and applications contemplated by Buyer shall be the sole responsibility of Buyer. The end user/installer/buyer shall be liable for the product's performance and suitability regarding their specific intended applications. End users should perform their own tests to determine suitability for each application.



HARMSCO® Filtration Products

P.O. Box 14066, North Palm Beach, FL 33408

(561) 848-9628 • Toll-free: (800) 327-3248 • Fax: (561) 845-2474 • E-mail: sales@harmsco.com

www.harmsco.com



Made in USA

© Harmsco, Inc. 26B 11 7/11

HARMSCO®

Liquid Filter Bags

Industrial Applications

Designed with Snap Fit “V” Ring to prevent bypass

- Harmsco replacement bags are constructed using 100% synthetic fibers in polypropylene or polyester material. The proper combination of fiber diameter, weight and thickness results in an economical depth filter media.

Features

- ▶ Available micron ratings: 1, 5, 10, 25, 50, 100 and 200
- ▶ Broad chemical compatibility
- ▶ High flow/low pressure drop
- ▶ Sewn construction
- ▶ Handles on all bags
- ▶ Molded plastic snap-seal to prevent bypass
- ▶ Temperatures up to 275°F (135°C)
- ▶ Extended baskets and bags offer longer filtration cycles and more media (extended) for longer runs



STD #1 Bag

STD #2 Bag

Extended Area Bags Available

Applications

- ▶ Paint
- ▶ Process Water Filtration
- ▶ Plating Solutions
- ▶ Coatings
- ▶ Lubricants
- ▶ Coolants
- ▶ Solvents
- ▶ Hydraulic Fluids
- ▶ Cutting Fluids
- ▶ Ground Water Remediation
- ▶ Industrial Waste Water Treatment



HARMSCO® Filtration Products



Made in USA

Specifications

- ▶ **Filter Media:** PO - Polypropylene; PE - Polyester
- ▶ **pH Range:** 3 - 11
- ▶ **Temperature:** PO - 200°F (93°C); PE - 275°F (135°C)
- ▶ **Dimensions:** Diameter - 7.06" (all bags)
Length - 16" (#1-STD; #1-EXT); 32" (#2-STD; #2-EXT)

▶ Flow Rate*:

Bag Size	Max GPM	Max LPM	Max M ³ /Hr
#1-STD	90	341	20.4
#2-STD	200	757	45.4
#1-EXT	90	341	20.4
#2-EXT	200	757	45.4

*Flow rates shown above are for guidelines only. Actual flow rates are based on bag type, micron rating, viscosity, solids content and a number of other factors.

Bag Information

Standard and Extended Bag Selection by Micron Size

#1 Standard Bags			#2 Standard Bags			#1 Extended Bags			#2 Extended Bags		
Filter Models: BCB-1-1.5-STD, BCB-1-2-STD, HSB-1			Filter Models: BCB-2-1.5-STD, BCB-2-2-STD, HSB-2, HMB Series			Filter Models: BCB-1-1.5-EXT, BCB-1-2-EXT			Filter Models: BCB-2-1.5-EXT, BCB-2-2-EXT		
Product Code	Micron	No./Case	Product Code	Micron	No./Case	Product Code	Micron	No./Case	Product Code	Micron	No./Case
PO-1-G1PS-SA	1	50	PO-1-G2PS-SA	1	50	PO-1-G1PS-EA	1	25	PO-1-G2PS-EA	1	25
PE-1-G1PS-SA	1	50	PE-1-G2PS-SA	1	50	PE-1-G1PS-EA	1	25	PE-1-G2PS-EA	1	25
PO-5-G1PS-SA	5	50	PO-5-G2PS-SA	5	50	PO-5-G1PS-EA	5	25	PO-5-G2PS-EA	5	25
PE-5-G1PS-SA	5	50	PE-5-G2PS-SA	5	50	PE-5-G1PS-EA	5	25	PE-5-G2PS-EA	5	25
PO-10-G1PS-SA	10	50	PO-10-G2PS-SA	10	50	PO-10-G1PS-EA	10	25	PO-10-G2PS-EA	10	25
PE-10-G1PS-SA	10	50	PE-10-G2PS-SA	10	50	PE-10-G1PS-EA	10	25	PE-10-G2PS-EA	10	25
PO-15-G1PS-SA	15	50	PO-15-G2PS-SA	15	50	PO-15-G1PS-EA	15	25	PO-15-G2PS-EA	15	25
PE-15-G1PS-SA	15	50	PE-15-G2PS-SA	15	50	PE-15-G1PS-EA	15	25	PE-15-G2PS-EA	15	25
PO-25-G1PS-SA	25	50	PO-25-G2PS-SA	25	50	PO-25-G1PS-EA	25	25	PO-25-G2PS-EA	25	25
PE-25-G1PS-SA	25	50	PE-25-G2PS-SA	25	50	PE-25-G1PS-EA	25	25	PE-25-G2PS-EA	25	25
PO-50-G1PS-SA	50	50	PO-50-G2PS-SA	50	50	PO-50-G1PS-EA	50	25	PO-50-G2PS-EA	50	25
PE-50-G1PS-SA	50	50	PE-50-G2PS-SA	50	50	PE-50-G1PS-EA	50	25	PE-50-G2PS-EA	50	25
PO-100-G1PS-SA	100	50	PO-100-G2PS-SA	100	50	PO-100-G1PS-EA	100	25	PO-100-G2PS-EA	100	25
PE-100-G1PS-SA	100	50	PE-100-G2PS-SA	100	50	PE-100-G1PS-EA	100	25	PE-100-G2PS-EA	100	25
PO-200-G1PS-SA	200	50	PO-200-G2PS-SA	200	50	PO-200-G1PS-EA	200	25	PO-200-G2PS-EA	200	25
PE-200-G1PS-SA	200	50	PE-200-G2PS-SA	200	50	PE-200-G1PS-EA	200	25	PE-200-G2PS-EA	200	25

Harmsco® Bag Housing Options



BCB Series STD
(Standard)

BCB Series EXT
(Extended Surface Area)

HSB Series

HMB Series

Note: This publication is to be used as a guide. The data within has been obtained from many sources and is considered to be accurate. Harmsco does not assume liability for the accuracy and/or completeness of this data. Changes to the data can be made without notification. Temperature, Pressure, Flow Rates, Differential Pressures, Chemical Combinations and other unknown factors can affect performance in unknown ways. **Limited Warranty:** Harmsco warrants their products to be free of material and workmanship defects. Determination of suitability of Harmsco products for uses and applications contemplated by Buyer shall be the sole responsibility of Buyer. The end user/installer/buyer shall be liable for the product's performance and suitability regarding their specific intended applications. End users should perform their own tests to determine suitability for each application.



HARMSCO® Filtration Products

P.O. Box 14066, North Palm Beach, FL 33408

(561) 848-9628 • Toll-free: (800) 327-3248 • Fax: (561) 845-2474 • E-mail: sales@harmsco.com

www.harmsco.com



Made in USA

© Harmsco, Inc. 44A 10 7/11

Filter Cartridges – Tab 31

NSF Listed Cartridges

All Harmsco® cartridges made with Polyester-Plus™, Poly-Pleat™ and Harmsco-Free media are NSF-61 Listed; HAC and WaterBetter® carbon cartridges are NSF/ANSI Standard 42 for material requirements only

Hurricane® (Tab 21) Polyester-Plus™, Poly-Pleat™, Harmsco-Free Cartridges

- ▶ High flow, high surface area
- ▶ Low initial pressure drop provides longer filter life
- ▶ Lowest cost per filtered gallon based on surface area



Premium & WaterBetter® (Tab 22) Cartridges

- ▶ 2-1/2" and 2-3/4" O.D. pleated cartridges designed for Harmsco® HIF, Band Clamp and competitive filter housings
- ▶ Available in 9-3/4", 10", 20", 30" and 40" cartridge lengths
- ▶ All cartridges shrink wrapped



701 Series Cartridges (Tab 23)

- ▶ 2-1/2" O.D. pleated cartridges designed for Harmsco® and competitive filter housings
- ▶ 9-3/4", 10", 20", 30" and 40" lengths; Polyester, Harmsco-Free™ and Poly-Pleat™ media
- ▶ All cartridges shrink wrapped



Calypso Blue™ Cartridges (Tab 24)

- ▶ 4-1/2" O.D. pleated cartridges designed for Harmsco® HIF, Band Clamp and single cartridge housings
- ▶ Premium Series offers up to 12 sq.ft. of media per 9-3/4" length; WaterBetter® Series 9.5 sq. ft.
- ▶ All cartridges shrink wrapped



Poly-Pleat™ Cartridges (Tab 26)

- ▶ Pleated one micron absolute cartridges for safe, cyst-free drinking water
- ▶ Available in a wide range of cartridge sizes including Hurricane®



Carbon Cartridges (Tab 27)

- ▶ Premium HAC Carbon and WaterBetter® Carbon Block cartridges for high chlorine, taste, odor, lead, THM and organic chemical removal
- ▶ Available in a wide range of cartridge sizes

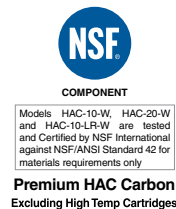

Note: This publication is to be used as a guide. The data within has been obtained from many sources and is considered to be accurate. Harmsco does not assume liability for the accuracy and/or completeness of this data. Changes to the data can be made without notification. Temperature, Pressure, Flow Rates, Differential Pressures, Chemical Combinations and other unknown factors can affect performance in unknown ways. **Limited Warranty:** Harmsco warrants their products to be free of material and workmanship defects. Determination of suitability of Harmsco products for uses and applications contemplated by Buyer shall be the sole responsibility of Buyer. The end user/installer/buyer shall be liable for the product's performance and suitability regarding their specific intended applications. End users should perform their own tests to determine suitability for each application.

HARMSCO®

At Work

Applications

Cooling Tower Filtration



Hurricane® filter installed on a forced draft cooling tower. Solids have been removed and customer reports he has been able to clean his cartridge over 25 times!

Surface Water Filtration



Hurricane® filters, 20- and 5-micron sediment cartridges (for pre-filtration) and 1-micron absolute rated Poly-Pleat™ cartridges for cryptosporidium control. Test results show removal requirements were achieved.

Environmental Compliance



A metal finishing plant installed several Hurricane® filters with 0.35- and 1-micron cartridges to lower zinc levels in their effluent. After installation the firm was in compliance and written approval was granted.

Reverse Osmosis Pre-Filtration



Four SB Hurricane® Swing Bolt housings were installed in parallel as pre-RO filtration using 5-micron cartridges flowing at 3,200 gpm.

Industrial Waste Water Treatment



A Harmsco® filtration system was engineered for an oil refracting site to clean up the effluent waste stream to meet new federal standards.

Water Bottling Plant



An international bottling plant installed two HIF 150FL filters in parallel with 1-micron absolute cartridges offering 2,600 sq.ft. of media, thereby maximizing their run time.

Desalination Pre-Filtration



Four HIF 200FL-COAT filter housings were installed as pre-filters to a sea water RO on a cruise ship. These housings have been successfully running for the past seven years.

Drinking Water Filtration



A small rural water customer installed five NSF-61 Listed HUR 1x170FL filter housings using two 5-micron NSF-61 Listed pre-filter cartridges followed by three 1-micron absolute cartridges.

Pleated vs. String Wound



A municipal customer replaced their string wound cartridges with Harmsco® 701-5/40 pleated cartridges and experienced four times the filter life resulting in lower operation cost.

Note: This publication is to be used as a guide. The data within has been obtained from many sources and is considered to be accurate. Harmsco does not assume liability for the accuracy and/or completeness of this data. Changes to the data can be made without notification. Temperature, Pressure, Flow Rates, Differential Pressures, Chemical Combinations and other unknown factors can affect performance in unknown ways. **Limited Warranty:** Harmsco warrants their products to be free of material and workmanship defects. Determination of suitability of Harmsco products for uses and applications contemplated by Buyer shall be the sole responsibility of Buyer. The end user/installer/buyer shall be liable for the product's performance and suitability regarding their specific intended applications. End users should perform their own tests to determine suitability for each application.

HARMSCO®

Liquid Filtration Applications

Typical Applications

- ▶ Remove Undispersed Solids
- ▶ Remove Precipitated Solids
- ▶ Protect Catalyst Beds
- ▶ Protect Instruments
- ▶ Remove DE Filter Carryover
- ▶ Keep Spray Nozzles Open
- ▶ Filter Recirculating Water
- ▶ Remove Particles From Coatings
- ▶ Filter Cooling Tower Water
- ▶ Remove Char Particles
- ▶ Filter Condensate
- ▶ Filter Bottle/Can Wash Water
- ▶ Filter Poultry/Meat Wash Water
- ▶ Clean Electrolytic Solutions
- ▶ Filter Waste Oil For Reuse
- ▶ Remove Plastic Fines From Water
- ▶ Filter Scrubber Water Filter
- ▶ Remove Pulp From Juices
- ▶ Boiler Feed Water
- ▶ Filter Pump Seal Water
- ▶ Protect Glue Applicators
- ▶ Protect Reverse Osmosis Systems
- ▶ Protect Chiller And Air Conditioners
- ▶ Remove Oversize Particles From Slurries

Liquids, By Industry

Chemical	Food	Paper	Petroleum	Misc.
Acetic Acid	Chocolates	Clay Slurry	Amine	Adhesives
Brine	City/Well Water	Cooling Water	Completion Fluids	Beer
Calcium Carbonate	Corn Syrup	Decker Shower Water	Cooling Tower Water	Beverages
Cooling Tower Water	Dextrose	Dyes	Feedstocks	Cooling Water
Ethylene Glycol	Edible Oils	Fresh Water	Fuel Oil	Dyes
Herbicides	Extracts	Mill Water	Hydraulic Oil	Liquor
Hydrochloric Acid	Jelly	Pigmented Coatings	Injection Fluids	Paints
Latices	Juices	Pump Seal Water	Motor Oil	Pharmaceuticals
Pelletizer Water	Lard	Size	Naphtha	Resins
Polymers	Milk Sugar	Starch	Pump Seal Water	Shampoo
Resins	Peanut Butter	Tio2 Slurry	Reduced Crudes	Solvents
Sulphuric Acid	Soybean Concentrate	Wet End Additives		Toothpaste
	Tea Liquor	White Water		

Note: This publication is to be used as a guide. The data within has been obtained from many sources and is considered to be accurate. Harmsco does not assume liability for the accuracy and/or completeness of this data. Changes to the data can be made without notification. Temperature, Pressure, Flow Rates, Differential Pressures, Chemical Combinations and other unknown factors can affect performance in unknown ways. **Limited Warranty:** Harmsco warrants their products to be free of material and workmanship defects. Determination of suitability of Harmsco products for uses and applications contemplated by Buyer shall be the sole responsibility of Buyer. The end user/installer/buyer shall be liable for the product's performance and suitability regarding their specific intended applications. End users should perform their own tests to determine suitability for each application.

HARMSCO®

Cooling Water/Chill/Heating/Boiler Water Filtration

Problems

Open Loop Towers are subject to wind-blown contamination from debris including leaves, seeds and pollen from trees, plants, shrubs and seedlings. Sand and turbidity from make-up waters as well as biological growth may form from time to time without proper chemical treatment.

Closed Loops and Boilers have problems associated with turbidity in make-up water, scale, colors and biological growth.

Filtration Advantages

- ▶ Helps eliminate fouling from suspended solids
- ▶ Improves circulation
- ▶ Improves efficiency of heat exchange units
- ▶ Lowers energy costs
- ▶ Reduces wear-and-tear of pumps, seals, etc.
- ▶ Reduces blow-down frequency
- ▶ Reduces water consumption
- ▶ Lowers maintenance costs (to clean heat exchangers and basins)
- ▶ Reduces downtime due to maintenance problems
- ▶ Lowers chemical costs
- ▶ Helps to eliminate nutrients for Legionella

HARMSCO®

Cooling Tower Utilizing Hurricane® Filter

Hurricane® Filter Installation

Open Loop Cooling Tower

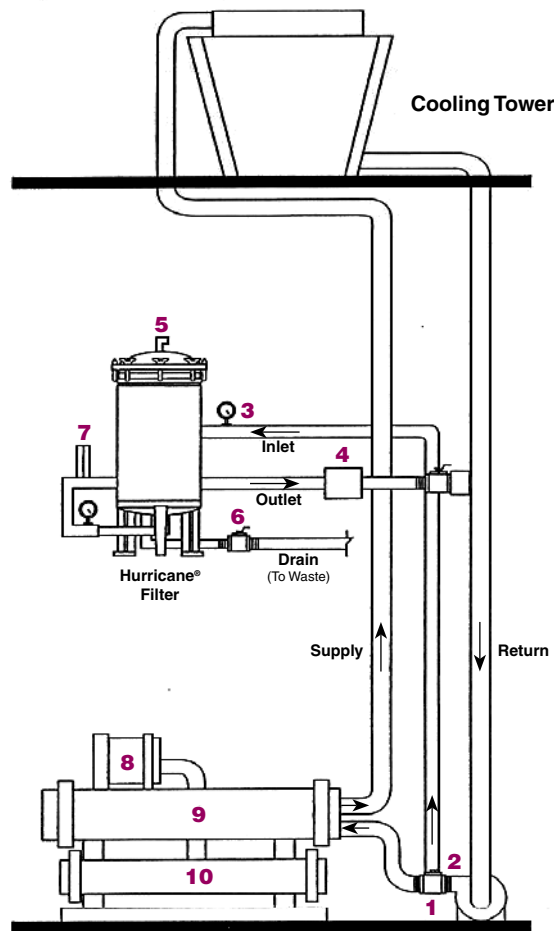

- | | | | |
|----|---|-----|-----------------------|
| 1. | 2-1/2" Thread-let | 6. | Ball valve (typical) |
| 2. | 2-1/2" Full-flow ball valve with 3" nipple on inlet | 7. | Flow meter (optional) |
| 3. | Pressure gauge | 8. | Compressor (existing) |
| 4. | Check valve | 9. | Condenser (existing) |
| 5. | 1/4" MPT petcock or 1/4" plug | 10. | Evaporator (existing) |

Note: This publication is to be used as a guide. The data within has been obtained from many sources and is considered to be accurate. Harmsco does not assume liability for the accuracy and/or completeness of this data. Changes to the data can be made without notification. Temperature, Pressure, Flow Rates, Differential Pressures, Chemical Combinations and other unknown factors can affect performance in unknown ways. **Limited Warranty:** Harmsco warrants their products to be free of material and workmanship defects. Determination of suitability of Harmsco products for uses and applications contemplated by Buyer shall be the sole responsibility of Buyer. The end user/installer/buyer shall be liable for the product's performance and suitability regarding their specific intended applications. End users should perform their own tests to determine suitability for each application.

HARMSCO®

About Filtration

Selecting Filter Housings and Cartridges

Many factors must be considered when selecting the appropriate filter housing and cartridge element for new filter applications. The following is a list of basic reasons for considering filtration in your process:

**Clarification
Classification**

**Equipment Protection
Sterilization**

**Product Standardization
Re-use of Liquids or Solids**

**Energy Conservation
Pollution Control**

Cartridge Element Selection

► **1 - Determine the nature of the contaminant.**

First determine exactly what you want the filter to remove and whether the material is hard, fibrous or gelatinous. This is very important because some types of filters work better than others for each contaminant type. For example, you wouldn't want to use a screen filter to remove a gel because the gel would, under pressure, break apart or pass through the screen.

► **2 - Degree of filtration required.**

In general, the finer the filter the more it costs. Therefore, the most economical filter selection is accomplished by determining exactly what removal rating is required to do your filtration. In some cases, where the filters are protecting an operation or piece of equipment, this can be easily accomplished, but in most applications where filtration is used to refine a product, testing a variety of media is the best method for this determination. If this is the case, your local Harmsco® representative can help in the testing process.

► **3 - Compatibility of the filter element.**

Be certain to include the operating temperature, pressure and application in this determination.

► **4 - Overall cost of operation.**

Include labor and cost of disposal in this calculation. Sometimes the filter element that may cost a little more to purchase may be easier to dispose of or lasts longer. For example, one HC/170 Series Hurricane® cartridge is equal to 43 standard 9-3/4" pleated cartridges. The Hurricane® cartridges cost more to buy, but cost less to use, resulting in lower operating cost.

Filter Housing Selection

► **1 - Filter Housing Materials.**

Filter housing materials must be compatible with the process in which it is being used. Be sure to include operating temperature, pressure and regulatory requirements imposed by local, State and Federal agencies.

► **2 - Filter Housing Sizing.**

Flow requirements, solids loading, viscosity of the material being filtered and pressure drop requirements will determine the number (or size) of cartridges (surface area) needed and thus the size of the filter housing. Always oversize your filter housing by 25-30% allowing for future growth and efficiency.

Surface Area Comparison

When filtering sediment, sand, grit or any other contaminant where "filter cake" can build on the cartridge media, it is Harmsco's view that pleated cartridge elements offer the lowest cost per filtered gallon. This is based on run time, pressure drop and efficiency. The following diagrams compare the Harmsco® Hurricane® System vs. standard housings with 2-1/2" diameter cartridges. Parameters below are based on 1,360 sq. ft. of media (surface area) at 840 gpm with a flow (flux) rate of 0.6176 gpm per sq. ft. of media.

Hurricane® High-flow Pleated System

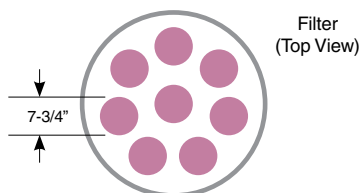

Competitive Pleated System

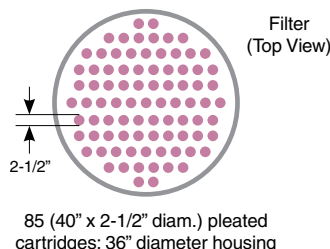

Competitive String Wound System

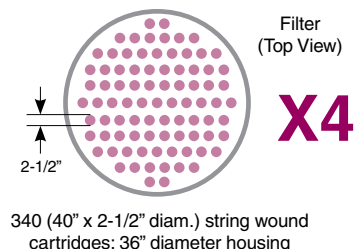

Note: This publication is to be used as a guide. The data within has been obtained from many sources and is considered to be accurate. Harmsco does not assume liability for the accuracy and/or completeness of this data. Changes to the data can be made without notification. Temperature, Pressure, Flow Rates, Differential Pressures, Chemical Combinations and other unknown factors can affect performance in unknown ways. **Limited Warranty:** Harmsco warrants their products to be free of material and workmanship defects. Determination of suitability of Harmsco products for uses and applications contemplated by Buyer shall be the sole responsibility of Buyer. The end user/installer/buyer shall be liable for the product's performance and suitability regarding their specific intended applications. End users should perform their own tests to determine suitability for each application.

Filter Application Specification Form

To receive Harmsco's product recommendation, please complete and email to sales@harmsco.com or fax to (561) 845-2474. For assistance, call our customer service department at (561) 848-9628 or (800) 327-3248 (toll-free).

Contact Information

Distributor Name		Contact Person
Location		
Phone	Fax	Email

Process Data

Fluid Being Filtered	pH	Concentration %	
Viscosity	CP	CKS	Other
Specific Gravity	Density	Lbs/ft ³	Kg/m ³
Process Service	Hrs/day	Days/week	Weeks/year
Flow Rate	US GPM	L/min	M ³ /hr
Operating Pressure	PSIG	Operating Temperature	°F °C
Maximum Differential Clean	PSID	Maximum Differential Loaded	PSID
Description of Contaminant	Particle Size Distribution		
Total Suspended Solids (TSS)	Desired Micron Rating	Removal Efficiency	Nominal or Absolute
NTU			
Spent Media Disposal	Nonhazardous	Hazardous	Other
Existing Filtration	Yes / No	If yes, what type?	
U-Stamp Vessel Required	Yes / No		
Pipe Size Required			
Other			

HARMSCO®

Relative Size of Particles

Relative Particle Size

Substance	Size
▶ Table Salt	100 microns
▶ Human Hair (average)	50-70 microns
▶ White Blood Cell	25 microns
▶ Talcum Powder	10 microns
▶ Cocoa	8-10 microns
▶ Red Blood Cell	8 microns
▶ Bacteria (cocci)	2 microns

Note: lower limit that can be seen by naked eye...40 microns.

Viscosity of Common Liquids

Liquid	Viscosity (CPS*)	Viscosity (SSU*)	Temperature (F)
Asphalt, virgin	539 - 2,810	2,500 - 12,000	250°
Bone oil	47.5	220	130°
Carbolic acid, phenol	11.83	65	65°
Castor oil	259.8 - 324.7	1,200 - 1,500	100°
Coconut oil	29.8 - 31.6	140 - 148	100°
Cod oil	32.1	150	100°
Cottonseed oil	37.9	176	100°
Linseed oil, raw	30.5	143	100°
Molasses, C	2,630 - 5,500	17,000 - 250,000	100°
Oil, Fuel N° 2	3.0 - 7.4	36 - 50	70°
SAE N° 30	86.6 - 125.5	400 - 580	100°
Olive oil	43.2	200	100°
Peanut oil	42	195	100°
Printer's ink	550 - 2,200	2,500 - 10,000	100°
Turpentine	2.11	33	60°
Varnish, spar	143	650	100°
Water, fresh	1.13	31.5	60°

* CPS = Centipoise; SSU = Saybolt Seconds Universal

Note: This publication is to be used as a guide. The data within has been obtained from many sources and is considered to be accurate. Harmsco does not assume liability for the accuracy and/or completeness of this data. Changes to the data can be made without notification. Temperature, Pressure, Flow Rates, Differential Pressures, Chemical Combinations and other unknown factors can affect performance in unknown ways. **Limited Warranty:** Harmsco warrants their products to be free of material and workmanship defects. Determination of suitability of Harmsco products for uses and applications contemplated by Buyer shall be the sole responsibility of Buyer. The end user/installer/buyer shall be liable for the product's performance and suitability regarding their specific intended applications. End users should perform their own tests to determine suitability for each application.

HARMSCO®

Mesh To Micron Conversion Chart

U.S. Mesh	Inches	Microns	Millimeters
3	0.2650	6,730	6.730
4	0.1870	4,760	4.760
5	0.1570	4,000	4.000
6	0.1320	3,360	3.360
7	0.1110	2,830	2.830
8	0.0937	2,380	2.380
10	0.0787	2,000	2.000
12	0.0661	1,680	1.680
14	0.0555	1,410	1.410
16	0.0469	1,190	1.190
18	0.0394	1,000	1.000
20	0.0331	841	0.841
25	0.0280	707	0.707
30	0.0232	595	0.595
35	0.0197	500	0.500
40	0.0165	400	0.400
45	0.0138	354	0.354
50	0.0117	297	0.297
60	0.0098	250	0.250
70	0.0083	210	0.210
80	0.0070	177	0.177
100	0.0059	149	0.149
120	0.0049	125	0.125
140	0.0041	105	0.105
170	0.0035	88	0.088
200	0.0029	74	0.074
230	0.0024	63	0.063
270	0.0021	53	0.053
325	0.0017	44	0.044
400	0.0015	37	0.037

Note: This publication is to be used as a guide. The data within has been obtained from many sources and is considered to be accurate. Harmsco does not assume liability for the accuracy and/or completeness of this data. Changes to the data can be made without notification. Temperature, Pressure, Flow Rates, Differential Pressures, Chemical Combinations and other unknown factors can affect performance in unknown ways. **Limited Warranty:** Harmsco warrants their products to be free of material and workmanship defects. Determination of suitability of Harmsco products for uses and applications contemplated by Buyer shall be the sole responsibility of Buyer. The end user/installer/buyer shall be liable for the product's performance and suitability regarding their specific intended applications. End users should perform their own tests to determine suitability for each application.

HARMSCO®

Chemical Compatibility Chart

Guide To Reading Recommendations

- R** ▶ Recommended
- F** ▶ Fair - may be acceptable; testing strongly recommended
- N** ▶ Not recommended
- O** ▶ No data available

Harmsco, Inc. offers this chart for informational and specification purposes only. For best results on all products and chemicals it is recommended that you either consult with a Harmsco Technical Engineer or conduct independent application-specific testing.

Typical Materials of Construction

Filter Cartridges

- ▶ Cartridge end caps are PVC or urethane
- ▶ Cartridge center tubes are ABS/PP/PVC
- ▶ Cartridge media is Polyester-Plus™

Filter Housings

- ▶ Stainless steel is 304
- ▶ Rim gaskets and top seals are EPDM
- ▶ O-rings are Buna-N
- ▶ Bottom seals are natural gum rubber
- ▶ Other seals available (e.g. Viton)

Note: This publication is to be used as a guide. The data within has been obtained from many sources and is considered to be accurate. Harmsco does not assume liability for the accuracy and/or completeness of this data. Changes to the data can be made without notification. Temperature, Pressure, Flow Rates, Differential Pressures, Chemical Combinations and other unknown factors can affect performance in unknown ways. **Limited Warranty:** Harmsco warrants their products to be free of material and workmanship defects. Determination of suitability of Harmsco products for uses and applications contemplated by Buyer shall be the sole responsibility of Buyer. The end user/installer/buyer shall be liable for the product's performance and suitability regarding their specific intended applications. End users should perform their own tests to determine suitability for each application.

Chemical	Buna-N	EPDM	Polyester	Plastisol/ PVC	304
Acetaldehyde	N	F	F	N	R
Acetamide	R	R	N	O	O
Acetic Acid 5%	R	R	R	R	R
Acetic Acid 50%	F	R	R	R	R
Acetic Acid 80%	F	F	R	R	R
Acetic Acid 100%	F	F	R	N	R
Acetic Amhydride	N	F	R	N	R
Acetone	N	R	R	N	R
Acetophenode	N	R	N	O	R
Acetyl Chloride	N	N	F	O	R
Acetylene	N	N	O	R	R
Acrylic Acid	O	O	R	O	R
Acrylonitrile	N	N	R	O	R
Adipic Acid	O	O	O	R	R
Air, Compressed	R	R	R	R	R
Aluminum Acetate	F	R	R	R	R
Aluminum Ammonium Sulfate	O	O	O	O	O
Aluminum Chloride 5%	R	R	R	R	R
Aluminum Fluoride 5%	R	R	R	R	F
Aluminum Hydroxide	R	O	R	R	R
Aluminum Nitrate	R	R	O	R	R
Aluminum Sulfate	R	R	R	R	R
Ammonia Gas (Dry)	R	N	R	R	R
Ammonium Bicarbonate	N	R	O	O	R
Ammonium Bromide 10%	R	F	O	O	R
Ammonium Carbonate 10%	N	R	F	R	R
Ammonium Chloride 10%	R	R	R	R	R
Ammonium Fluoride 10%	R	R	R	R	R
Ammonium Hydroxide 30%	R	R	R	R	R
Ammonium Nitrate 5%	R	R	R	R	R
Ammonium Phosphate	R	R	O	R	R
Ammonium Sulfate 5%	R	R	R	R	R
Ammonium Thiocyanate	R	R	R	R	R
Amyl Acetate	N	R	R	O	O
Amyl Alcohol	F	R	R	R	R
Aniline,	N	F	R	N	R
Aqua Regia	N	N	F	R	N
Arsenic Acid	R	R	O	R	R
Asphalt	F	N	O	O	R
Aviation fuel	R	N	R	O	R
Banana Oil (Amyl Acetate)	N	R	R	N	R
Barium Carbonate	R	R	R	R	R
Beer	R	R	R	R	R
Beet Sugar Liquors	R	R	R	R	R
Benzene	N	N	R	N	R
Bromine (Dry)	N	N	N	N	N
Bromine (ONet)	N	N	N	R	N
Butane	R	N	R	R	R
Butanoic Acid	O	O	O	O	R
Butyl Acetate	N	R	R	R	R
Butyl Alcohol	R	F	R	R	R
Butyl Cellosolve	R	F	O	O	R
Butyl Chloride	O	O	O	O	R
Butyric Acid	N	F	R	N	R
Calcium Chloride	R	R	R	R	F

Chemical	Buna-N	EPDM	Polyester	Plastisol/ PVC	304
Calcium Hydroxide 5%	R	R	R	R	R
Calcium Hypochlorite	R	R	R	R	N
Cane Sugar liquors	R	R	R	R	R
Carbolic Acid (Phenol)	N	F	N	R	R
Carbon Dioxide (Dry)	R	F	O	R	R
Carbon Disulfide	N	N	R	N	R
Carbon Tetrachloride	F	N	R	R	R
Carbonated Water	R	R	R	R	R
Carbonic Acid	F	R	O	R	R
Castor Oil	R	F	R	R	R
Caustic Potash	F	R	O	R	R
Caustic Soda	F	R	O	R	R
Cellosove	N	F	O	R	R
Chloracetic Acid	N	F	F	R	R
Chlorine Gas (Dry)	N	F	O	R	R
Chlorine Gas (Wet)	N	F	O	R	F
Chlorobenzene	N	N	R	N	R
Chloroform (Dry)	N	N	R	N	R
Chromic Acid	N	F	R	R	R
Cider	F	R	R	R	R
Citric Acid -	R	R	R	R	R
Cod Liver Oil	R	R	R	R	R
Coffee Extract	R	O	R	F	R
Cola Syrup	O	O	R	O	R
Copper Sulfate	R	R	R	R	R
Corn Oil	R	N	R	R	R
Cottonseed Oil	R	N	R	R	R
Cresol	O	N	N	O	O
Creosote	R	N	O	R	R
Cresylic Acid	N	N	R	R	R
Cyclohexane	R	N	R	N	R
Cyclohexamone	N	F	R	N	R
DDT Solution	O	O	O	O	F
Dextrose	R	R	R	R	R
Diacetone Alcohol	N	R	R	N	R
Dibutyl Phthalate	N	F	O	O	R
Dichloroethane	N	N	O	O	R
Dichloroethylene	O	O	O	O	R
Diesel Fuel	R	N	O	R	R
Diethanolamine	R	F	E	O	O
Diethylene GIYCI	R	R	R	O	R
Dimethyl Formamide	N	O	R	O	R
Diphenyl Oxide	N	N	O	O	R
Dowtherm	N	N	O	O	R
Epichlorohydrin	N	F	R	O	R
Ethanol	R	R	R	O	R
Ethanolamine	F	F	O	O	R
Ether	N	N	R	O	R
Ethyl Acetate	N	F	R	N	R
Ethyl Cellulose	F	F	O	O	R
Ethylene Diamine	R	R	O	O	R
Ethylene Glycol	R	R	R	R	R
Ethylene Oxide	N	N	O	N	R
Fatty Acids	R	F	R	R	R
Ferric Chloride 1 %	R	R	R	R	N

Chemical	Buna-N	EPDM	Polyester	Plastisol/ PVC	304
Ferric Chloride	R	R	R	R	N
Ferric Nitrate	R	R	R	R	R
Ferric Sulfate 5%	F	R	R	R	R
Ferrous Chloride	R	O	R	O	R
Fish Oils	R	O	R	R	R
Fluosilicic Acid	F	R	O	R	R
Formaldehyde 10%	R	F	R	R	R
Formalin 40%	N	F	O	R	R
Formic Acid (low con.)	F	R	R	R	F
Formic Acid (Cone.)	F	R	R	O	F
Freon 12	F	F	O	N	R
Freon 22	N	R	O	N	R
Fruit Juices	R	R	R	R	R
Fuel Oils	R	N	R	R	R
Furfural	N	F	O	N	R
Gas, Natural	R	N	R	R	R
Gasoline, Sour	R	N	O	R	R
Gasoline, Motor	R	N	O	R	R
Gasoline, Aviation	R	N	O	R	R
Gelatin	R	R	R	R	R
Glucose	R	R	R	R	R
Glycerine-Glycerol	R	R	R	R	R
Glycol	R	R	N	R	R
Glycol Monoether	R	R	O	R	R
Grease	R	N	R	R	R
Green Sulfate Liquor	F	R	O	O	R
Gum Arabic	O	R	O	O	O
Helium	R	R	R	O	R
Hexane	R	N	R	R	R
Honey	R	R	R	R	R
Hydraulic Oil, Petroleum Base	R	N	R	R	R
Hydraulic Oil, Phosphate Ester	N	R	R	R	O
Hydrazine	F	R	O	O	R
Hydrobromic Acid 10%	N	R	R	R	N
Hydrobromic Acid 50%	N	R	O	R	N
Hydrochloric Acid 5%	R	R	F	R	N
Hydrochloric Acid 30%	R	R	F	R	N
Hydrocyanic Acid 5%	F	R	O	R	R
Hydrocyanic Acid	F	R	O	R	R
Hydrofluoric Acid 10%	R	R	N	R	N
Hydrofluoric Acid 50%	O	O	O	O	N
Hydrogen Gas	R	R	O	R	R
Hydrogen Peroxide 5%	F	R	F	R	R
Hydrogen Peroxide 30%	N	F	F	R	R
Hydrogen Sulfide (Dry)	R	R	O	R	R
Hydrogen Sulfide (Wet)	N	R	O	R	F
Hydroquinone	N	N	R	R	R
Iodine	F	F	F	N	R
Isopropyl Acete	N	F	O	O	F
Isopropyl Alcohol	F	R	R	R	R
Kerosene	R	N	R	R	R
Ketchup	R	O	R	R	R
Lactic Acid	R	R	R	E	N
Lard Oil	R	F	R	R	R
Latex (Natural)	R	O	R	R	R

Chemical	Buna-N	EPDM	Polyester	Plastisol/ PVC	304
Lead Acetate	F	R	R	R	R
Lime-Sulfur	N	R	0	0	R
Linoleic Acid	F	N	0	R	R
Linseed Oil	R	N	R	R	R
Lithium Bromide	0	0	0	R	R
Lithium Carbonate	R	0	0	0	0
Lithium Chloride	R	N	R	R	R
Lithium Hydroxide	R	R	0	0	R
Lube Oil	R	N	R	R	R
Lye	F	R	R	R	R
Magnesium Chloride	R	R	R	R	R
Magesium Hydroxide	F	R	0	R	R
Magnesium Sulfate	R	R	0	R	R
Mayonnaise,	R	0	R	R	R
Melamine Resin)	R	0	0	0	N
Mercuric Chloride 10%	R	R	R	R	F
Mercurous Nitrate	F	R	0	R	R
Mercury	R		R	R	R
Methane	R	N	0	R	R
Methylene Chloride	N	N	R	N	R
Methyl Alcohol	R	R	R	R	R
Methyl Acetate	N	F	R	R	R
Methyl Cellosolve	N	F	0	N	F
Methyl Chloride	N	N	R	N	R
Methyl Ethyl Ketone (MEK)	N	R	R	N	R
Milk	R	R	R	R	R
Mineral Oil	R	N	R	R	R
Molasses	R	0	R	R	R
Monoethanolamine	N	R	0	0	R
Mustard	R	0	0	0	R
Naphtha	F	N	R	R	R
Napthalene	N	N	R	N	R
Nickel Chloride	R	R	R	R	N
Nickel Sulfate	R	R	0	R	R
Nitric Acid 10%	N	F	F	R	R
Nitric Acid 20%	N	N	F	R	R
Nitric Acid 50%	N	N	F	R	R
Nitric Acid Fuming	N	N	N	N	F
Nitrobenzene 10%	N	N	R	N	R
Nitrobenzene	N	N	R	N	R
Nitrogen	R	R	R	R	R
Nitrous Oxide	F	0	0	R	R
Oil, Crude	F	N	R	R	R
Oleic Acid 5%	R	R	0	R	R
Oleum	N	N	0	N	R
Olive Oil	E	F	R	R	R
PAlc Acid 5%	F	R	F	R	R
Palm Oil	R	0	R	R	R
Pentane	R	N	0	R	R
Perchloroethylene (Dry)	F	N	R	R	R
Petroleum Ether	F	N	R	R	R
Petroleum Oil, Refined	R	N	R	R	R
Petroleum Oil, Sour	F	N	R	R	R
Phenol	N	F	F	R	R
Phenol Formaldehyde Resin	0	F	0	0	R

Chemical	Buna-N	EPDM	Polyester	Plastisol/ PVC	304
Phosphoric Acid 1 %	R	R	R	R	R
Phosphoric Acid 10%	R	R	R	R	R
Phosphoric Acid 50%	R	R	F	R	R
Phosphoric Acid 80%	R	R	F	R	R
Picric Acid	R	R	R	N	R
Pine Oil	R	N	R	R	R
Arsenic	R	R	0	R	R
Brass, Bronze, Cadium and Copper Cyanide	R	R	0	R	R
Cadium Fluoborate	R	R	0	R	R
Copper Cyanide	R	R	0	R	R
Gold Cyanide	R	R	0	N	R
Iron Chloride	N	R	0	N	R
Lead Alkali	R	R	0	R	R
Lead Fluoborate	R	R	0	R	R
Nickel Bright Chloride	R	R	0	R	R
Nickel Dull Fluoborate	0	R	0	N	R
Silver	R	R	0	R	R
TIn Acid	R	R	0	R	0
TIm Fluborate	R	R	0	R	R
Zinc Chloride	R	R	N	R	N
Zinc Cyanide	R	R	0	R	R
Zinc Fluoborate	0	R	0	N	R
Potassium Acetate 10%	F	R	0	0	R
Potassium Bisulfate 10%	0	0	R	0	R
Potassium Carbonate 10%	R	R	F	R	R
Potassium Chloride 5%	R	R	R	R	R
Potassium Chromate 10%	R	F	0	R	R
Potassium Cyanide 5%	R	R	0	R	R
Potassium Ferrocyanide 10%	F	R	0	R	R
Potassium Permanganate 5%	R	R	F	R	R
Potassium Sulfate 5%	R	R	R	R	R
Propane	R	N	R	R	R
Propionic Acid	0	R	R	R	R
Propylene Glycol	R	R	R	R	R
Propylene Oxide	N	R	0	0	0
Pyridene	N	F	R	0	R
Sea Water	R	R	R	R	N
Shellac	R	R	R	0	R
Silver Nitrate	F	R	F	R	R
Soda Ash	R	R	R	R	R
Sodium Acetate	F	R	R	R	R
Sodium Bicarbonate	R	R	R	R	R
Sodium Bisulfate	R	R	R	R	R
Sodium Bisulfite	R	R	R	0	R
Sodium Borate	R	R	R	R	R
Sodium Carbonate	R	R	R	R	R
Sodium Chlorate	R	0	0	R	R
Sodium Chloride 10%	R	R	R	R	F
Sodium Cyanid	R	R	R	R	R
Sodium Fluoride 5%	R	R	R	R	R
Sodium Hydroxide 5%	F	R	R	R	R
Sodium Hydroxide 20%	F	R	N	R	R
Sodimh Hydroxide 40%	F	F	N	R	R
Sodium Hypochlorite 5%	F	R	F	R	R
Sodium Metaphosphate	R	R	0	R	R

Chemical	Buna-N	EPDM	Polyester	Plastisol/ PVC	304
Sodium Nitrate 5%	F	R	R	R	R
Sodium Perborate 1%	F	R	R	R	R
Sodium Peroxide	F	R	N	R	R
Sodium Phosphate	R	R	R	R	R
Sodium Polysulfide	O	O	O	O	R
Sodium Silicate	R	R	O	R	R
Sodium Sulfate	R	R	R	R	R
Sodium Sulfide	R	R	R	N	R
Sodium Thiocyanate	O	O	R	R	R
Sodium Thiosulfate	F	R	R	R	R
Soybean Oil	R	N	R	R	R
Stannic Chloride 5%	R	R	R	R	N
Stannous Chloride 5%	R	R	R	R	R
Starch	R	R	R	R	R
Steam	R	R	R	N	R
Stearates	R	R	R	R	R
Stearic Acid	F	F	O	R	R
Stoddard Solvent	R	N	R	N	F
Sucrose Solutions	R	R	O	R	R
Sulfate Liquors	F	F	O	R	F
Sulfur Dioxide (Dry)	N	R	O	R	R
Sulfur Trioxide (Dry)	N	F	O	R	R
Sulfuric Acid 5%	F	R	R	R	R
Sulfuric Acid 50%	N	N	R	R	F
Sulfuric Acid 96%	N	N	N	N	R
Sulfuric Acid Fuming	N	N	N	N	R
Sulfurous Acid	F	F	O	N	N
Tannic Acid 10%	R	R	R	R	R
Tartaric Acid	R	F	O	R	R
Tertrachloreteylene (Dry)	N	N	O	N	R
Tetrachloroethane	N	N	R	R	R
Tetrahydrofuran	N	F	O	N	R
Toluene	N	N	R	N	R
Transformer Oil	R	N	R	R	R
Trichloroethylene .(Dry)	N	N	R	N	R
Triethanolamine	F	F	R	N	R
Trisodium Phosphate	R	R	R	R	R
Tung Oil	R	N	R	R	R
Turpentine	R	N	R	R	R
Urea-Formaldehyde	O	O	O	O	O
Vanilla Extract	O	O	O	O	R
Varnish	F	N	O	O	R
Vegetable Oils	R	N	R	R	R
Vinegar	F	R	R	R	R
Water, Fresh	R	R	R	R	R
Water, Salt	R	R	R	R	N
Waxes	O	O	O	O	R
Whiskey	R	R	R	R	R
Wine	R	R	R	R	R
Xylene	N	N	R	N	R
Zinc Bromide	R	O	O	O	R
Zinc Cyanide	R	O	O	O	R
Zinc Sulfate	R	R	R	R	R

Note: Specialty coated filter housings available for sea water, chlorides and other chemicals not compatible

HARMSCO®

Solutions for Small Community Water Supply

Town of Shenandoah, Virginia

Problem

The **Township of Shenandoah, Virginia** was forced to comply with new regulations being enforced by the United States EPA concerning the removal of Cryptosporidium and Giardia Cysts from surface waters. Previously, no filtration was required.

Application

Ground water under the influence of surface water.

Site Characteristics

Turbidity	0.5 NTU
Existing Filtration	None
Flow Rate	450 GPM

Alternatives Considered

The Township of Shenandoah considered the following three alternatives:

1. Standard water treatment plant (\$500,000 total equipment cost).
2. Reverse osmosis (cost was undisclosed but considered too expensive).
3. Six Harmsco HUR-850-ASME filters...three with 5-micron cartridges and three with 0.35 micron cartridges (costs were a fraction of the costs associated with a conventional water treatment plant).

The Harmsco Advantage

- ▶ Low capital costs
- ▶ Filter housings meet ASME design requirements and come with “U” stamp.
- ▶ 5-micron cartridges used for pre-filtration are cleanable and reusable.
- ▶ 0.35-micron cartridges used for final filtration meet 3 log (99.9%) removal requirements described in EPA requirements.
- ▶ Compact design requiring a smaller building, compared to conventional equipment.
- ▶ Easy installation compared to conventional equipment.

Note: 0.35 micron cartridges used, prior to introduction of Poly-Pleat™ cartridges.

Solutions for Small Community Water Supply

Town of Shenandoah, Virginia

Results

Pilot Test

William F. Wise, P.E. was employed by the township to complete pilot testing using two Harmsco® Hurricane® HUR-850-ASME filter housings, installed in series. Five Harmsco® HC-170-5 (5 micron nominal) cartridges were installed in the first housing and five Harmsco® HC-170-0.35 (0.35 micron nominal) cartridges were installed in the final filter housing.

Pilot Test Results

Flow rate	150 gph
Influent NTU	0.5
Effluent NTU	0.4
Gallons filtered to reach 20 PSID	52,950,000
Duration to reach 20 PSID	10 months
Cartridge costs per 1,000 gallons	\$0.125 (at list prices)

Challenge Tests (conducted by independent laboratory)

Test Results

Cryptosporidium removal	3.3 log (> 99.9%)
Giardia cyst removal	3.5 log (> 99.9%)

Note: Tests conducted by Clancy Environmental Consultants, Inc. using live cysts.

Final Results

At the conclusion of the pilot tests, the Township of Shenandoah, Virginia purchased four additional Harmsco® Hurricane® HUR-850-ASME filters. They are now using Harmsco® equipment to filter the entire township's water requirements.

For Additional Information

Please contact Harmsco Filtration Products and ask for a copy of the Shenandoah project and test results from Clancy Environmental Consultants, Inc.

Note: This publication is to be used as a guide. The data within has been obtained from many sources and is considered to be accurate. Harmsco does not assume liability for the accuracy and/or completeness of this data. Changes to the data can be made without notification. Temperature, Pressure, Flow Rates, Differential Pressures, Chemical Combinations and other unknown factors can affect performance in unknown ways. **Limited Warranty:** Harmsco warrants their products to be free of material and workmanship defects. Determination of suitability of Harmsco products for uses and applications contemplated by Buyer shall be the sole responsibility of Buyer. The end user/installer/buyer shall be liable for the product's performance and suitability regarding their specific intended applications. End users should perform their own tests to determine suitability for each application.

HARMSCO®

Cryptosporidium and Giardia Cysts Control

Cryptosporidium

A protozoan or single celled parasite that lives in the intestines of animals and humans. This microscopic pathogen causes gastrointestinal disorders and may result in death.

Giardia Lamblia Cysts

A cyst occurring primarily in surface water as a result of influence by human and animal fecal waste. Causes gastrointestinal disorders and may result in death.

Log Removal

1 part in 10 parts = 1 log (90%)
1 part in 100 parts = 2 log (99%)
1 part in 1,000 parts = 3 log (99.9%)

Note

Generally, one micron absolute cartridges are required to remove Cryptosporidium and Giardia Cysts.

Standards of Performance

- ▶ SDWA - Safe Drinking Water Act
- ▶ SWTR - Surface Water Treatment Rule
- ▶ NSF 53 - cyst reduction (only for point of use equipment having 1" pipe size or smaller)
- ▶ NSF 61 - additives (leaching of filter components to water supply)
- ▶ Challenge tests conducted by independent testing facility (filter housing and cartridge)
- ▶ Western States Protocol
- ▶ LT2 Challenge test

People to Contact

- ▶ State and local health departments
- ▶ State Department of Environment
- ▶ Community water systems
- ▶ Specifying engineers
- ▶ Mechanical contractors
- ▶ Industrial and municipal distributors
- ▶ Rural water associations in your state

Best Advice

Recommend only products that have been validated by an independent testing facility for the filter housing and filter cartridge.

Note: This publication is to be used as a guide. The data within has been obtained from many sources and is considered to be accurate. Harmsco does not assume liability for the accuracy and/or completeness of this data. Changes to the data can be made without notification. Temperature, Pressure, Flow Rates, Differential Pressures, Chemical Combinations and other unknown factors can affect performance in unknown ways. **Limited Warranty:** Harmsco warrants their products to be free of material and workmanship defects. Determination of suitability of Harmsco products for uses and applications contemplated by Buyer shall be the sole responsibility of Buyer. The end user/installer/buyer shall be liable for the product's performance and suitability regarding their specific intended applications. End users should perform their own tests to determine suitability for each application.

HARMSCO®

Surface Water

Solids Content

- High** ▶ Very turbid water in the 20 NTU range or more. For high solids a backwashing, multi media filter may be required, plus two Harmsco® filters down stream for final filtration...one with 5 micron cartridges and one with absolute rated 1 micron Poly-Pleat™ cartridges.
- Average** ▶ Typical lake, river, stream or reservoir water. Here, what has worked best is a three-train system. One filter with 20 micron cartridges, one with 5 micron cartridges and a final filter with Poly-Pleat™ cartridges.
- Low** ▶ Water in the 1 NTU range or below. Here, use a two-train system...one filter with 5 micron cartridges and one with Poly-Pleat™ cartridges.
- Very Low** ▶ Spring, ground or even municipal water in the 0.5 NTU range or below. Use one filter with Poly-Pleat™ cartridges (unless a pre-filter is needed for surface water with higher turbidity during spring time run-off).

Cartridge Life Span

Harmsco® Polyester Cartridges

Harmsco® cartridges are pleated for more surface area so they provide long life. Also, the polyester media is cleanable so Harmsco® cartridges are reusable to further reduce costs.

Harmsco® Poly-Pleat™ Cartridges

Based on filtration tests, the following throughput is typical:

Filter Housing	Filter Cartridge	Gallons To 30 PSID
HUR 90 HP	PP-HC-90-1	1,000,000
HUR 90 HP	PP-HC-170-1	1,800,000

Other Guidelines and Suggestions

To select the pipe sizes that meet the customer's requirements, contact us at Harmsco or visit our website at www.harmsco.com.

HARMSCO®

Cartridge Cleaning Instructions

Harmsco® filter cartridges are cleanable and reusable in most applications and micron ratings. For best results, clean cartridges when pressure differential is 12-15 psi above start-up differential. If cartridges are to be replaced allow pressure differential to climb to 25-30 psi above start-up differential or when flow has diminished to an unacceptable level, indicating cartridge is at capacity.

Cleaning Instructions

Cartridge Cleaning in Aqueous Applications

Clean cartridges with pressure nozzle using standard hose. Direct spray at an angle to remove particulate. Follow these directions for best results:

▶ **Oils in aqueous solutions:**

Soak cartridges in a solution of tri-sodium phosphate or similar strong detergent (2 lbs. to 10 gallons of water). Soak up to 12 hours. Rinse after soaking.

▶ **Organic matter and algae in aqueous solution:**

Use tri-sodium phosphate or similar strong detergent as described above, plus 1 pint of liquid chlorine to kill organic matter and algae. Soak cartridges 1 hour or longer until surface is no longer slippery. Rinse after soaking.

▶ **Calcium & mineral deposits:**

Follow directions for oils described above. Rinse cartridges thoroughly for approximately 10 minutes in a solution of one part muriatic acid to 20 parts of water. Rinse cartridge thoroughly with water.

▶ **Potable water application:**

NSF Standard 60. Approved citric acid - refer to nsf.org

Caution:

Do not rinse cartridges with acid until oils and organic matter are removed. Use detergent first and follow with acid soak for mineral removal. Flush cartridges with water after muriatic or tri-sodium phosphate baths. Generally it is not possible to clean Harmsco® cartridges when filtering petroleum-based liquids, toxic substances and when using one micron and sub-micron cartridges.

HARMSCO®

Cleaning & Sanitizing Guide

For All-Poly/High Purity Cartridges

Cleaning

Use the following cleaning agents for cleaning filter cartridges. Immerse with cartridge open end up and soak in a container that has the prescribed concentration of the agent for at least 30 minutes.

- ▶ **Triton X-100:** add 15 drops of Triton X to one gallon (3.79 liters) of warm water and then mix well. Triton X is made by Roche Diagnostics.
- ▶ **LiquiNox/Alconox:** follow instructions provided by manufacturer on product packaging.
- ▶ **Minnclean TF:** add 30 grams of Minnclean to one gallon (3.79 liters) of warm water and mix well.

Sanitizing

Use the following sanitizing agents to properly sanitize cartridges prior to use in critical applications. Immerse with cartridge open end up and soak in the prescribed concentration of the agent for 30-60 minutes. For proper and effective sanitization raise the mixture's temperature to 80°F (27°C).

- ▶ **Sodium Hypochlorite (Bleach):** prepare a 5-10 ppm solution in lukewarm water.
- ▶ **70% Ethanol:** immerse the cartridges (Buna N O-rings not compatible).
- ▶ **70% IPA:** immerse the cartridges.
- ▶ **Chlorine Dioxide (ClO₂):** add 2 oz. (59 ml) of Chlorine Dioxide to one gallon (3.79 liters) of lukewarm water (200 ppm).
- ▶ **10% Hydrogen Peroxide:** immerse the cartridges in 10% H₂O₂.
- ▶ **Acid:** immerse the cartridges in 1% solution of citric, acetic, nitric, phosphoric or hydrochloric acid.
- ▶ **Peracetic Acid:** immerse cartridges in 100-200 ppm solution.
- ▶ **Caustic:** rinse cartridges or soak overnight in 0.5-5% NaOH solution. Hot caustic at 122°F (50°C) is even more effective. **Do not use on track etch type polyester membrane cartridges.**

Sterilizing

- ▶ **Hot Water:** raise clean water temperature to 176°F (80°C) and immerse the cartridges with open end up for 30 minutes. **For inline hot water flow, do not exceed 3 psid (.21 bar) pressure drop across the cartridge and 30 minute maximum circulation at stated temperature.**
- ▶ **Steam:** raise the steam temperature to 250°F (121°C) and expose the cartridge to steam for 30 minutes. **For inline hot steam, do not exceed more than 3 psid (.21 bar) pressure drop across the cartridge.***
- ▶ **Autoclave:** install the cartridges in the autoclave chamber. Raise steam temperature to 250°F (121°C) and expose the cartridge for 30 minutes.*

* Cartridge must be equipped with special end cap insert to withstand steaming or autoclaving.

Final Rinse

- ▶ **Final Rinse:** rinse all cleaned and sanitized cartridges with plenty of clean water to remove any remaining cleaning and sanitizing agents.

Note: This publication is to be used as a guide. The data within has been obtained from many sources and is considered to be accurate. Harmsco does not assume liability for the accuracy and/or completeness of this data. Changes to the data can be made without notification. Temperature, Pressure, Flow Rates, Differential Pressures, Chemical Combinations and other unknown factors can affect performance in unknown ways. **Limited Warranty:** Harmsco warrants their products to be free of material and workmanship defects. Determination of suitability of Harmsco products for uses and applications contemplated by Buyer shall be the sole responsibility of Buyer. The end user/installer/buyer shall be liable for the product's performance and suitability regarding their specific intended applications. End users should perform their own tests to determine suitability for each application.