

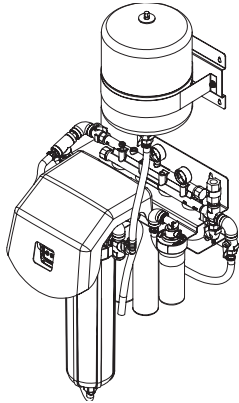

## EVERPURE® ENDURANCE® SC HIGH FLOW SYSTEMS

---



EV943740 Endurance SC High Flow Twin 1.0

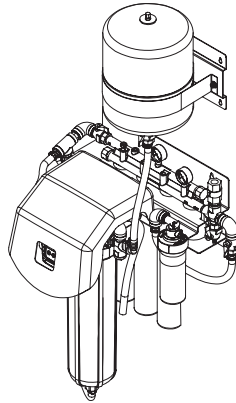

EV943741 Endurance SC High Flow Triple 1.1

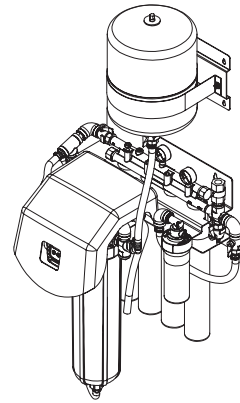

EV943742 Endurance SC High Flow Quad 1.1

### INTRODUCTION

---

The Everpure® Endurance® SC High Flow SEN Filter Systems are designed to treat up to 200,000 gallons of water per SEN Cartridge change cycle. The system uses a pretreatment Hollow Fiber Ultrafilter (HFUF), 2, 3 or 4 fine filter cartridges and a 2SR-BW Scale Inhibiting Cartridge. The Everpure Endurance SC High Flow Filter Systems will flush the pretreatment cartridge after 100\* gallons (378.5 L) or 24 hours, whichever comes first.

\*See Setting the Controller For Normal Operation.

## INSPECTION

Before mounting the Everpure Endurance SC High Flow System, inspect the parts. Use the table and illustration below to verify the parts and quantities. If any parts are missing, contact Customer Service at 630.307.3000 / 800.942.1153 (US only) or by email at CSeverpure@pentair.com.

Parts	Twin	Triple	Quad
1. Manifold with Bracket	1	1	1
2. Shroud	1	1	1
3. Hollow Fiber Ultrafilter (HFUF)	1	1	1
4. Pretreatment Housing	1	1	1
5. Housing Wrench	1	1	1
6. 2SR-BW Cartridge	1	1	1
7. SEN Cartridge	2	3	4
8. Port Plug for SEN Installed	2	1	0
9. Storage Tank Assy	1	1	1
10. 3/4-Inch Hose, 15 inches Long for Tank Connection	1	1	1
11. 3/8-inch Tubing, 12-foot Lengths for Flushing	2	2	2
12. Electrical Adapter (Attached to Control)	1	1	1
13. Bagged O-rings	2	2	2
14. Bag with two (2) Oetiker Clamps and two (2) Plastic Snap Grips for 2SR-BW Cartridge	1	1	1
15. Silicone Grease	3	3	3

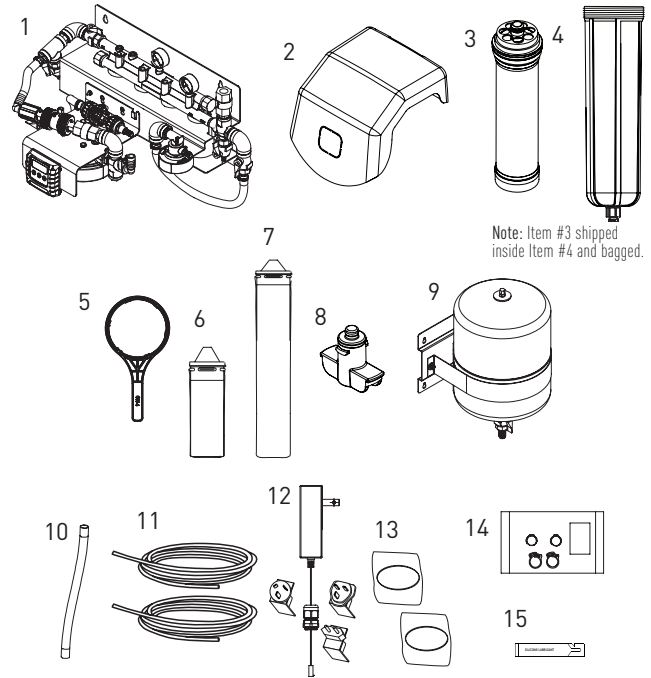



#### IMPORTANT PLEASE READ:

- The information, specifications and illustrations in this manual are based on the latest information available at the time of printing. The manufacturer reserves the right to make changes at any time without notice.
- This manual is intended as a guide only. This product should be installed by a plumbing professional.
- This unit is designed to be installed on potable water systems only.
- This product must be installed in compliance with all state and municipal plumbing and electrical codes. Permits may be required at the time of installation.
- If daytime operating pressure exceeds 80 psi, nighttime pressures may exceed pressure limits. A pressure reducing valve must be installed to keep maximum pressure below 100 psi (6.9 bar).
- Do not install the unit where temperatures may drop below 35°F (2°C) or above 100°F (38°C).
- Do not place the unit in direct sunlight or outdoors. Black units will absorb radiant heat increasing internal temperatures.
- Do not strike the controller or any of the components.
- Limited warranty of this product extends to manufacturing defects. Misapplication of this product may result in failure to properly condition water, or damage to product.
- A screen or sediment filter should be used on installations in which large, visible particles are present.
- Correct and constant voltage must be supplied to the controller to maintain proper function.

## SAFETY, CAUTIONS & WARNINGS

### Safety

The Everpure® Endurance® SC High Flow System must be wired according to local electrical codes to prevent the possibility of electrical shock.

Do not modify the power supply cord.

The Endurance SC High Flow System has been designed and tested to offer reliable service when installed by a qualified professional, and operated and maintained according to the instructions in this service manual.

For safety reasons, the Endurance SC High Flow System is furnished with a low voltage power transformer to plug into the electrical outlet. Do not replace this transformer with another power supply (except as supplied by the manufacturer).

Install the Endurance SC High Flow System only for its intended use as described in this service manual.

Do not use corrosive chemicals in the Endurance SC High Flow System.

Do not immerse the controller, cord or plug in water or water spray.

Keep the cord away from heated surfaces.

Disconnect the Endurance SC High Flow System from the power source before performing any service or maintenance.

Do not plug in the controller transformer if there is water on the controller, electrical wiring or the power supply.

Always shut off the water flow and release water pressure before cleaning or maintaining the Endurance SC High Flow System.

The Endurance SC High Flow System is intended for indoor use only. The power supply and controller must not be exposed to weather elements.

The outlet used for power to the Endurance SC High Flow System should be an unswitched outlet.

The appliance is only to be installed in locations where its use, maintenance and cleaning is restricted to trained adult personnel.

No one should play with the appliance, including children.

The appliance is not suitable for installation in an area where a water jet could be used and must not be cleaned with a water jet.

The controller and plug must be protected from water drops, spray or other water contact.

**WARNING: Prior to performing any service on a pressurized vessel/tank, eye protection and other suitable personal protection equipment should be worn. Isolate the water system, unplug the power and depressurize it. Drain the water that is inside the tank by opening the drain valve or by other means.**

Grounding Instructions: This appliance must be grounded. In the event of a malfunction or breakdown, grounding will reduce the risk of electric shock by providing a path of least resistance for electric current. This appliance is equipped with a cord which has an appliance-grounding

conductor and grounding plug. The plug must be plugged into an appropriate outlet that is installed and grounded in accordance with all local codes and ordinances. If the supply cord is damaged, it must be replaced by the manufacturer, its service agent or similarly qualified persons in order to avoid a hazard. If the AC adapter or cable is damaged, the AC adapter should be scrapped.

**WARNING: Improper connection of the appliance-grounding conductor can result in a risk of electric shock. Check with a qualified electrician or service representative if you are in doubt as to whether or not the appliance is properly grounded. Do not modify the plug provided with the appliance. If it will not fit the outlet, have a proper outlet installed by a qualified electrician or use the correct adapter from the selection included with this system.**

This appliance is not intended for use by persons (including children) with reduced physical, sensory or mental capabilities, or lack of experience and knowledge, unless they have been given supervision or instruction concerning use of the appliance by a person responsible for their safety.

Substances reduced are not necessarily in your water. System must be maintained according to manufacturer's instructions, including replacement of filter cartridges.

This system contains replaceable components critical to the efficient operation of the system. Replacement of these components must be of identical specifications and approved by the manufacturer or all claims and warranty are voided.

**NOTE: This product should be installed by a qualified professional. Comply with all plumbing and electrical codes when installing this product.**

**CAUTION: Minimum water pressure 50 psi (3.5 bar).  
Maximum water pressure 100 psi (6.9 bar).**

**CAUTION: Ambient temperature 35°F to 100°F (2°C to 38°C).**

**CAUTION: Disconnect all power sources before servicing.**

**CAUTION: Always operate the controller with the cover in place.**

**WARNING: The system MUST be depressurized before removing any connections for servicing.**

**Not for residential use. For food service applications only.**

Do not use with water that is microbiologically unsafe or of unknown quality without adequate disinfection before or after the system. Systems certified for cyst reduction may be used on disinfected waters that may contain filterable cysts.

The term "bacteriostatic" indicates that the system limits the passage or growth of bacteria that may already exist in the incoming water. It does not mean that the water leaving the system is safer to drink than the water entering the system.

**For installations in Massachusetts, the Commonwealth of Massachusetts Plumbing Code 248 CMR shall be adhered to. Consult your licensed plumber for installation of the system. This system and its installation must comply with state and local regulations.**

## SELECTING A LOCATION

**WARNING: Mounting surface may require reinforcement to safely support appliance. Hollow walls, drywall and other non-structured surfaces are not suitable unless reinforced.**

**IMPORTANT: Tank assembly must be mounted vertically with shut-off valve pointing down!**

The location selected for system installation should allow for:

- Adequate space for "in" and "out" water line connections.
- Mounting screws should anchor into a solid structure.
- The frame is designed to mount on 16-inch centers (wall studs).
- Allow five (5) inches below the cartridges for removal.
- The pretreatment housing can be removed from the frame and mounted separately. Be certain to use adequate lengths of opaque 3/4-inch beverage tubing.
- Give consideration to the weight of the system when filled with water. Operating weights of the Everpure® **Endurance® SC High Flow System** are:  
**Endurance SC High Flow Twin 1.0 System** - 64.65 lbs. (29.3 kg) without storage tank.  
**Endurance SC High Flow Triple 1.1 System** - 70.0 lbs. (31.7 kg) without storage tank.  
**Endurance SC High Flow Qu.ad 1.1 System** - 75.35 lbs. (34.2 kg) without storage tank.
- Wall space needed for the manifold and the storage tank assembly is an area 27 inches (68.9 cm) wide and 63 inches (160.0 cm) high. This will allow space for water connections.
- Tank operating weight is 42.4 lbs (19.3 Kg) when full.
- The electrical adapter cord is five (5) feet (1.5 m) in length. An electrical outlet should be nearby.

## OPERATING SPECIFICATIONS

---

- Temperature Limits: 35-100°F (2-38°C)
- Pressure Limits: 50-100 psi (3.5-6.9 bar)
- For cold water use only.
- Rated Service Flow:
  - Endurance SC High Flow Twin 1.0 System** - 7.5 gpm (28.4 Lpm)
  - Endurance SC High Flow Triple 1.1 System** - 11.25 gpm (42.6 Lpm)
  - Endurance SC High Flow Quad 1.1 System** - 15 gpm (56.8 Lpm)
- Service Life Between Everpure® SEN Cartridge Changes:
  - Endurance SC High Flow Twin 1.0 System** - 100,000 gal (378,541 L), six (6) months to one year based on usage.
  - Endurance SC High Flow Triple 1.1 System** - 150,000 gal (567,812 L), six (6) months to one year based on usage.
  - Endurance SC High Flow Quad 1.1 System** - 200,000 gal (757,082 L), six (6) months to one year based on usage.
- HFUF Hollow Fiber Ultrafilter - approximately three (3) year life.
- Electrical - Rated Voltage & Power Cord:
  - Input: 100-240 VAC/50-60 Hz
  - Output: 24 VDC, 2.7 Amp
- Branch Circuit Protection: 5 amp minimum. To minimize personnel shock hazards, install on a GFI, RCD, or equivalent protected circuit.

## PLUMBING CONNECTIONS

---

- Inlet: 3/4-inch (19 mm)
- Outlet Manifold: 3/4-inch FPT (19 mm)
- Backwash: 3/4-inch (19 mm) I.D. Tube
- Everpure® 2SR-BW Cartridge: 1/2-inch (13.6 mm ) Barb
- Flush Ports: 3/8-inch (9.5 mm ) Barb

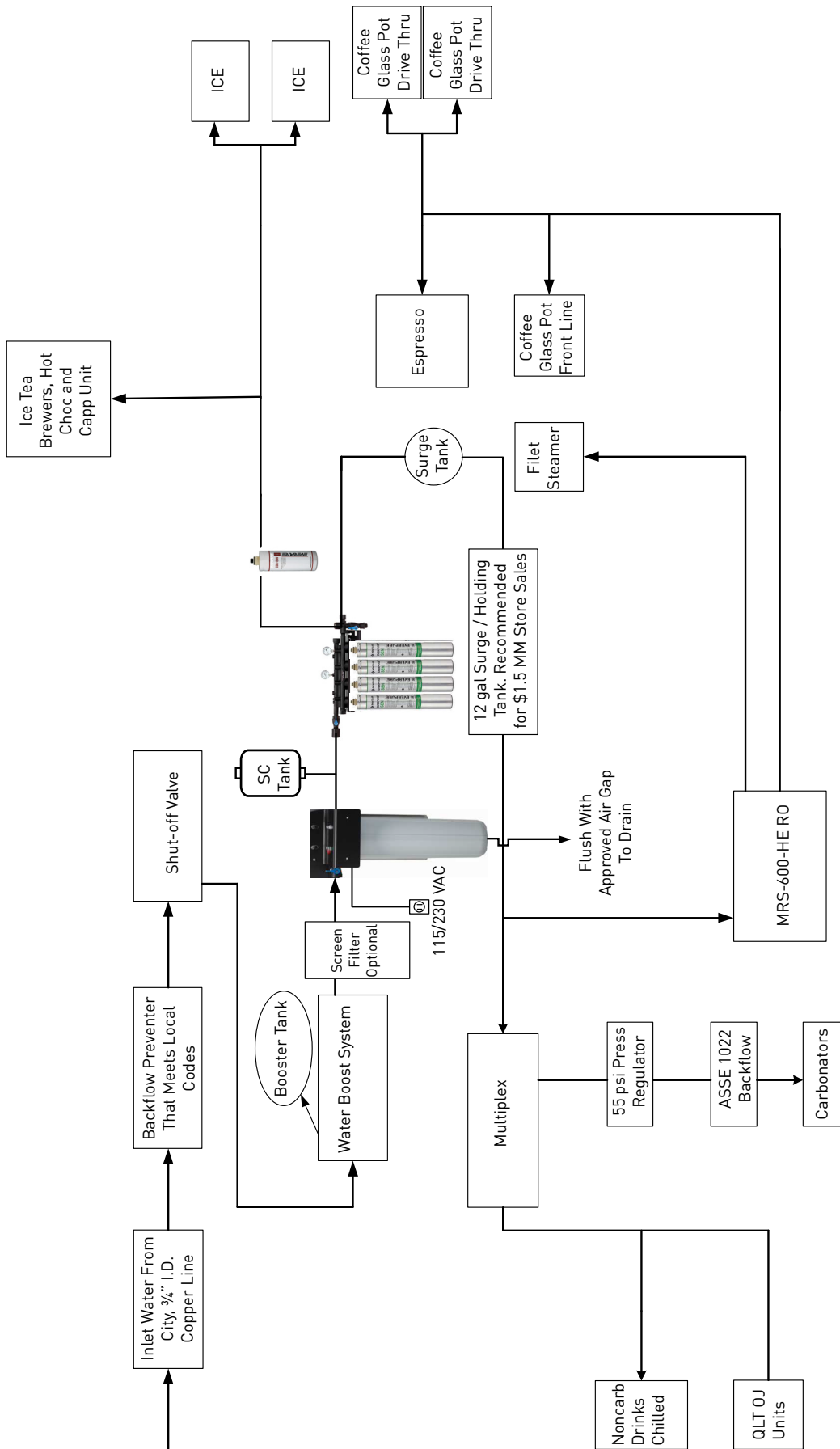

P&ID  
Including  
Endurance SC

## DIMENSIONS

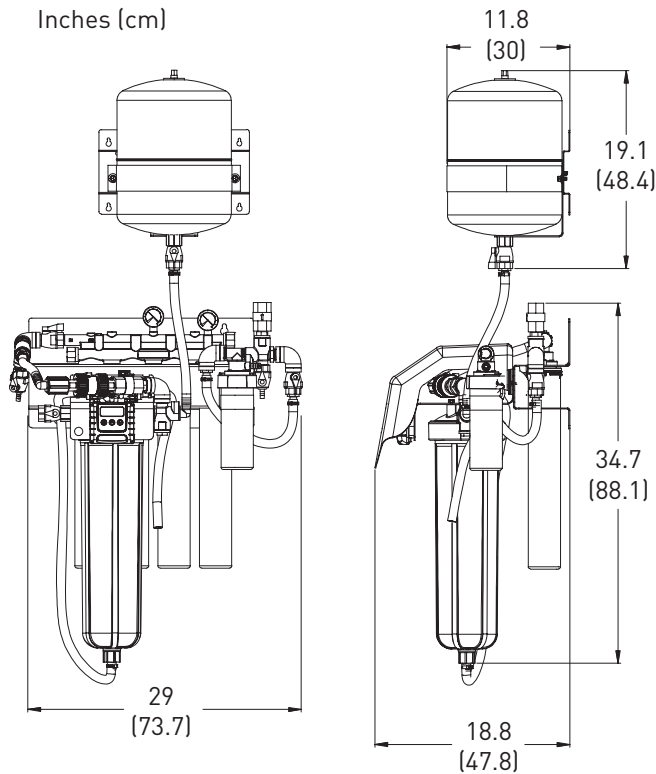

## INSTALLATION INSTRUCTIONS

1. The predrilled mounting holes in the bracket can be used as a guide. The holes are on 16-inch centers. Mark and insert anchors or screws in the wall.
2. Mount the manifold using four (4) screws in the bracket mounting holes. The slots will accept a 3/8-inch diameter lag bolt or screw.
3. Do not connect the treated water outlet ports to the equipment being served until after the system has been flushed (Figure 1).

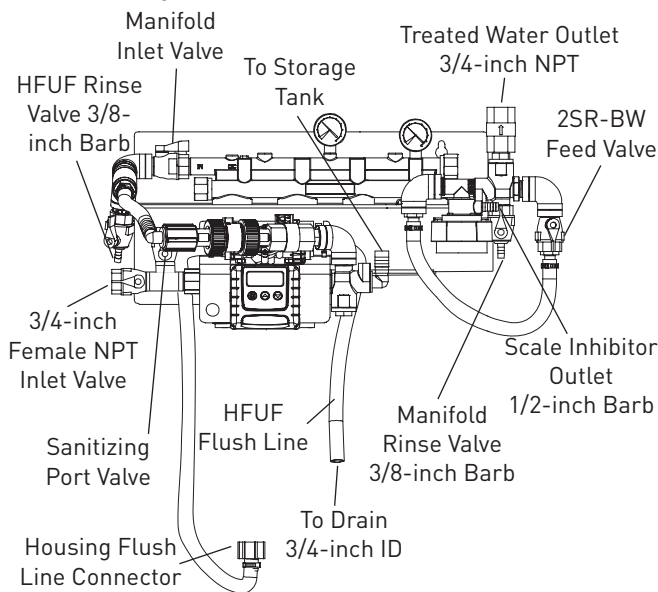

Figure 1

4. Attach one of the supplied 3/8-inch I.D. tubing to the fitting on the HFUF Flush Valve (Figure 1). Use one of the spring clamps to secure. Run the other end of the tubing to a drain.
5. Attach the second piece of 3/8-inch I.D. tubing to the fitting on the Manifold Rinse Valve (Figure 1). Use one of the spring clamps to secure. Run the other end to a drain.

**NOTE: Some plumbing codes require an air gap at the drain termination.**

6. The Everpure® 2SR-BW Cartridge has a shut-off valve on the inlet. Do not attach the tubing to the ice maker or hot beverage application at this time. Attach short tube for flushing.
7. Turn off the flow valves shown in Figure 1:
  - Inlet
  - HFUF Rinse
  - Manifold Inlet
  - Sanitizing
  - Manifold Rinse
  - Scale Inhibitor
8. The HFUF Cartridge is shipped inside the housing. Locate the bag with the housing and cartridge. Open the bag and remove the housing with the HFUF Cartridge still inside.

**CAUTION: Do not remove the HFUF Cartridge from the housing.**

9. Remove one of the o-rings from its shipping bag. Lubricate o-ring with the supplied silicone grease. Insert it into the cartridge housing groove (Figure 2) at the top edge of the housing.

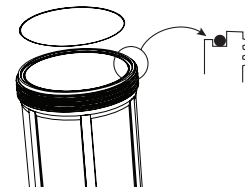

Figure 2

10. Check to be sure the two (2) top o-rings of the HFUF Cartridge are sufficiently lubricated and in the grooves. Use included silicone packets or a food-grade silicone lubricant, if needed. They should be seated and clean of debris. Thread the housing into the head by hand. Use a sump wrench to lightly tighten the housing onto the head. This can be tightened further if leaks occur. The two (2) o-rings at the top of the cartridge will fit snugly into the head. Thread Housing Flush Line Connector onto bottom of housing. Hand tighten.

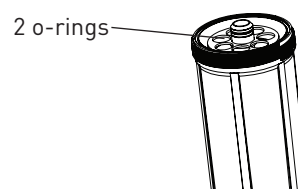

Figure 3

**NOTE: To install the Everpure® SEN Carbon Filter and 2SR-BW Scale Inhibitor Cartridges, align the cartridge lug with the label, push upward and rotate to the right until rotation stops.**

11. Install only genuine Everpure® SEN Carbon Filter Cartridge(s) into the filter head(s) following directions on the SEN cartridge label or as shown in the Cartridge Change Procedure illustrations. Install the 2SR-BW Scale Inhibitor Cartridge.

**CAUTION: Unused manifold ports must be plugged. Any ports that are not plugged will leak.**

**NOTE: The storage tank mounts above the manifold assembly. It must be mounted with the water tank valve at the bottom. Failure to mount tank with water valve down will void the warranty.**

12. A short piece of new 3/4-inch tubing (15 in./38.1 cm long) is provided with the system. Attach the tubing to the barb connection on the exit (right) side of the head for the Everpure® Endurance SC HFUF (Figure 1). Use one of the supplied Oetiker clamps to secure.
13. Mount the tank to allow a connection with the 3/4-inch tubing. The mounting holes will accept a 1/4-inch diameter lag bolt or screw.
14. Connect the 3/4-inch tubing to the barb connection on the storage tank. Use one of the supplied Oetiker clamps to secure.
15. Connect the incoming water supply to the inlet valve.
16. There are four (4) union connections above the controller that may loosen during shipping. Two (2) for the solenoid valve and two (2) for the turbine. Tighten each one by hand to secure the connection.
17. The storage tank air pressure must be set to 20 psi (1.37 bar). Unscrew the valve cap at the top of the tank. Open the tank ball valve at the bottom of the tank and open a single valve downstream to release pressure in the tank. Measure the internal pressure with an air gauge. Add or release pressure as needed until the pressure reads 20 psi (1.37 bar). Then screw valve cap back on.

**NOTE: The precharge pressure should be zero when initially checked. Charge the tank to the specified pressure, 20 psi (1.37 bar). It is advisable to check the precharge pressure again in the very near future to verify the precharge pressure has not changed. Loss of precharge pressure indicates a leak at the Schrader® valve, bladder or tank/seal.**

**NOTE: Check storage tank pressure every 6-12 months during regular cartridge change. If the tank pressure is below 20 psi (1.37 bar), recharge and check pressure more frequently.**

18. Connect carbonated and non-carbonated beverage outlet(s).

**WARNING: HFUF Flush Line peak flow is 12-15 gpm (45-57 Lpm). Mount discharge above drain with air gap that meets local and national standards. During start-up, check if drain capacity and flow are adequate to prevent flooding.**

## START-UP

At this point, the Everpure® Endurance® SC High Flow System should be completely installed with the exception of the scale inhibitor outlet. The quad system is shown in Figure 4.

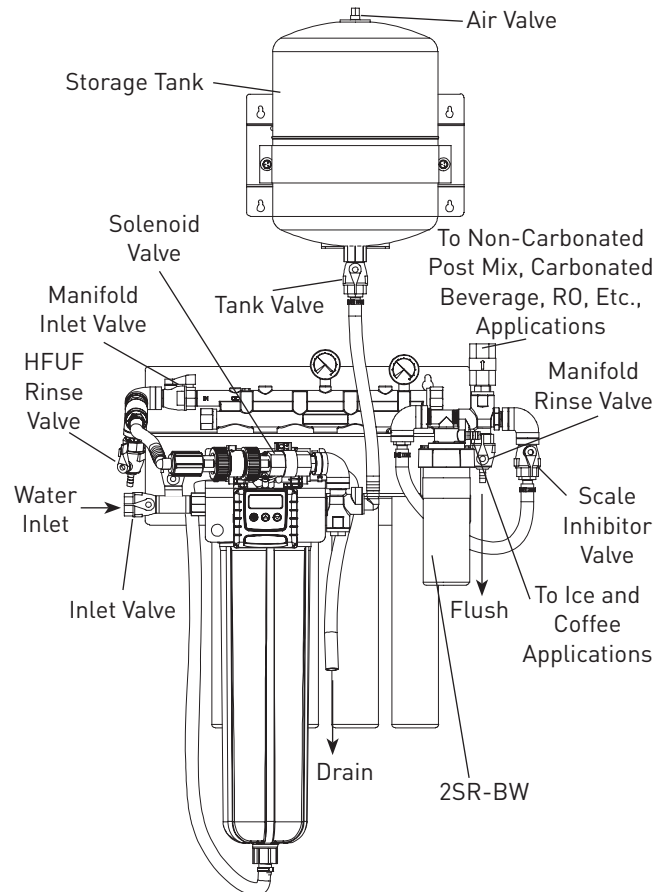

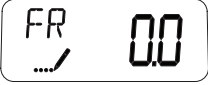
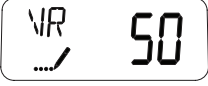
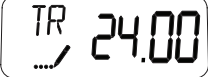

Figure 4



To start producing treated water, plug in the AC adapter. Use an outlet that is 115 VAC and not on a switch. For international installations, use the correct adapter for power supplied and install. Power supply can be used on 100-240 VAC, 50-60 Hz. The controller will not keep track of time or water usage when power is out. The controller will start up by displaying:

	SC	Displayed at power up only
	FR 0.0	Flow in gallons per minute
	VR 50	Volume in gallons remaining until flush
	TR 24.00	Time remaining until flush (will be counting down)

**NOTE: If these settings are not displayed correctly, contact Technical Support.**

When the controller has gone through this sequence, it will continue to display the FR, VR and TR information. You must now perform an Initial Flush and Cartridge Activation.

## INITIAL FLUSH AND CARTRIDGE ACTIVATION

Starting Positions for Valves:

- Inlet Valve - **Closed**
- Sanitizing Port Valve - **Closed**
- HFUF Rinse Valve - **Closed**
- Manifold Inlet Valve - **Closed**
- Manifold Rinse Valve - **Closed**
- Solenoid Flush Valve - **Closed** (Automatic, Electronic Control)
- Scale Inhibitor Valve - **Closed**
- Tank Valve - **Closed**

After new cartridges have been installed, the system should be flushed and the cartridges activated.

1. Open the HFUF Rinse Valve. Check that all cartridges and plugs are installed.

**WARNING: Do not quickly turn on the incoming water supply. A newly installed membrane will rupture and destroy its filtering capabilities.**

2. Slowly open the Inlet Valve to 1/4 open. Air should be exiting the HFUF Rinse Valve. Press the red pressure release on HFUF Housing to release trapped air.
3. When the rinse water is running steady and free of bubbles, open the Inlet Valve to full open. Close the HFUF Rinse Valve.
4. Perform a manual flush. Press the Cycle button  for five (5) seconds and release. The control will count down 60 seconds then open the Flush Solenoid for 15 seconds.

5. Open the HFUF Rinse Valve and run water for 15 minutes.
6. Open the Tank Valve.
7. Continue rinsing for an additional 30 minutes.

**NOTE: During this rinse period, it is likely the volume will exceed the threshold for a flush cycle. When the flow stops in Step 8, a flush cycle should start automatically. If this occurs, only two (2) cycles are needed in Step 9.**

8. Close the HFUF Rinse Valve.
9. Perform three (3) complete manual flush cycles (see Step 4).
10. Open the Manifold Rinse Valve.
11. Slowly open the Manifold Inlet Valve to 1/4 open. Air should be exiting the Manifold Rinse Valve.
12. When the rinse water is running steady and free of bubbles, open the Manifold Inlet Valve to full open.
13. Run rinse water for five (5) minutes.
14. Close the Manifold Rinse Valve.
15. Attach a hose to the outlet barb on the head. Direct it into a bucket or to a drain.
16. Slowly open the Scale Inhibitor Valve to 1/4 open.
17. When water exits the hose open the valve completely, flush for five (5) minutes.
18. Close the Scale Inhibitor Valve.
19. Remove the hose and connect the application.
20. Open the Scale Inhibitor Valve.
21. Set the controller for Normal Operation (see next section, "Setting the Controller for Normal Operation").

**WARNING: The controller settings must be changed from Start-up settings to Normal (production) settings. Failure to do so will damage the equipment and void any warranty.**

## SETTING THE CONTROLLER FOR NORMAL OPERATION

When the controller for the system is first plugged in, the display will show:

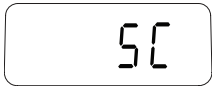

Followed by:



FR = Flow Rate



VR = Volume Remaining

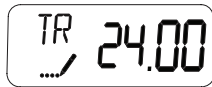

TR = Time Remaining (Counting Down)

When the Everpure® Endurance® SC High Flow System is operating, the FR, VR and TR displays will show in rotation.

To Enter the User Programming Mode:

**CAUTION: Changing these settings from the following recommendations, may adversely affect filter life.**

1. Press and hold ▲ and ▼ for six (6) seconds until "DV ALL" is displayed.
2. The first display is:



3. Press ⊕ to make changes.
4. The display will change to:

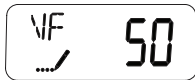

5. Change the gallons used between flush cycles using the ▲ and ▼ buttons. Change the VF setting to 100.

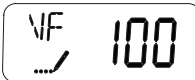

**WARNING: Do not change the Volume Remaining setting from 100 gallons without testing turbidity, total organic carbon and SDI15. Changing the Volume Remaining setting may damage the equipment. Refer to the table below.**

If water tests are:			The VR setting may be set to:
Turbidity	Total Organic Carbon	SDI15	
<5 NTU	<10 mg/L	<20	50 gal
<2.0 NTU	<2 mg/L	<6.67	100 gal
<1.0 NTU	<1 mg/L	<3.0	200 gal

Use these settings as a general recommendation for your application. For more detailed information, contact Technical Support.

6. Press ⊕ to accept and advance to the time between flush cycles.

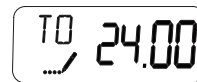

7. Default setting is 24 hours.
8. Press ⊕ to accept and advance to PS. The default program is PrG1 which provides a 15 second flush.

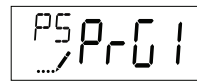

PS = Program Select

9. Use the ▲ and ▼ buttons to advance to PrG4, which will provide a four (4) second flush cycle.

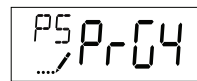

10. Press ⊕ to accept.

## SANITIZE - EVERY SIX (6) MONTHS

### Starting Positions for Valves:

- Inlet Valve - **Closed**
- Sanitize Port Valve - **Closed**
- HFUF Rinse Valve - **Closed**
- Manifold Inlet Valve - **Closed**
- Manifold Rinse Valve - **Closed**
- Solenoid Flush Valve - **Closed**, automatic electronic control
- Scale Inhibitor Valve - **Open**
- Tank Valve - **Open**

If the HFUF Cartridge and storage tank are to be sanitized, follow the procedure to the right.

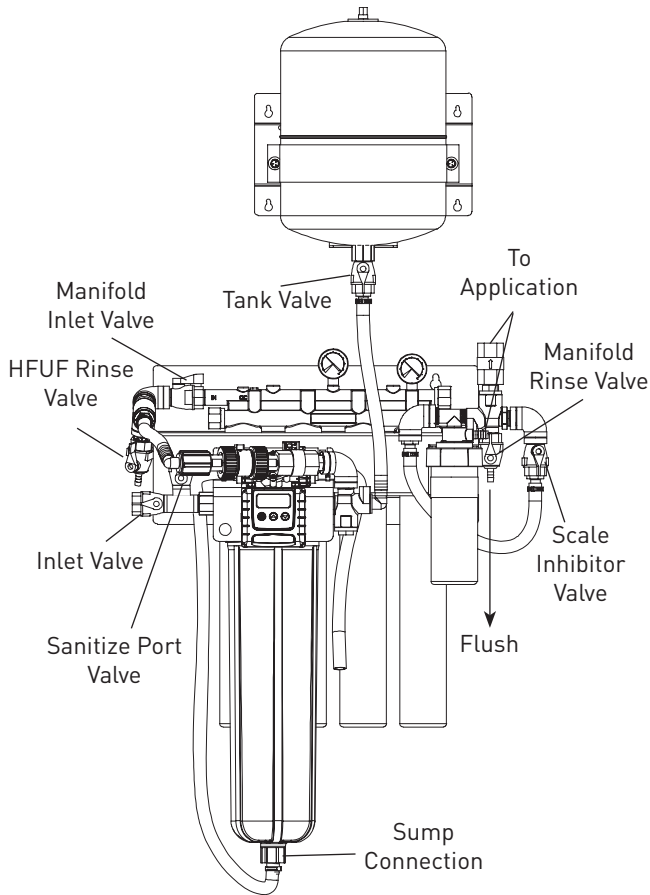

Figure 5

1. With the Inlet and Manifold Inlet Valves closed, perform a manual flush by pressing the Cycle button for five (5) seconds. This will reduce tank pressure.
2. Open the HFUF Rinse Valve to relieve any remaining pressure.
3. Open the Sanitize Port Valve in the tee fitting next to the Inlet Valve. It is likely that some water will spill out of the opening.



**CAUTION: Sodium hypochlorite (bleach) should be used for disinfection. The user should acquaint themselves with the appropriate safety precautions for storage and handling of the chemicals being used. USE ONLY SODIUM HYPOCHLORITE. DO NOT USE BLEACHES CONTAINING ANY OTHER COMPOUNDS.**

**NOTE: Use the opening in the Sanitize Port Valve to place bleach into the system. There must be room for two (2) tablespoons (1 oz./26.9 mL) of bleach. To drain water and create room, proceed with Step 4.**

4. Locate the connection at the bottom of the HFUF Housing. Loosen the connection to allow water to leak out.
5. Allow enough water to leak out to enable two (2) tablespoons (1 oz./26.9 mL) of bleach to be added. Hand-tighten this connection.
6. Place two (2) tablespoons (1 oz./26.9 mL) of bleach into the opening of the Sanitize Port Valve.
7. Close the Sanitize Port Valve.
8. Slowly open the Inlet Valve to 1/4 open.
9. Allow water to exit the HFUF Rinse Valve until a bleach (chlorine) smell is detected. Close the HFUF Rinse Valve.
10. Wait 15 minutes.
11. Fully open the Inlet Valve.
12. Perform three (3) manual flush cycles.
13. Open the HFUF Rinse Valve to drain until bleach smell is gone.
14. Close the HFUF Rinse Valve.
15. Open the Manifold Inlet Valve.
16. Resume operation.

## CARTRIDGE CHANGE PROCEDURE

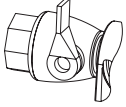
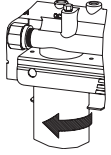
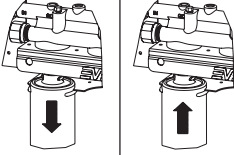
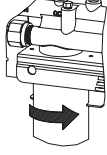
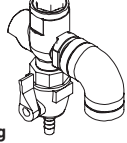
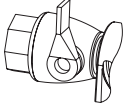
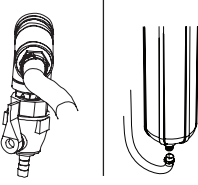
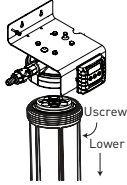
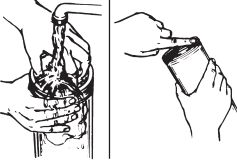
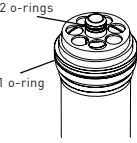
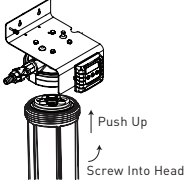
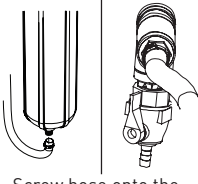
Place a pan below the cartridges to catch any water when removing cartridges. Inlet water must be turned off.

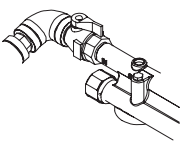
 <p><b>Everpure SEN Carbon Filter and 2SR-BW Scale Inhibitor Cartridge Change</b></p> <ol style="list-style-type: none"> <li>1. Shut off Manifold Inlet Valve ahead of Everpure®SEN Cartridges.</li> </ol>	 <ol style="list-style-type: none"> <li>2. Open Manifold Rinse Valve to relieve pressure.</li> <li>3. Hold head firmly and push upward. Turn cartridge to left until it stops.</li> </ol>	 <ol style="list-style-type: none"> <li>4. Pull old cartridge downward and out of head.</li> <li>5. Hold head firmly. Align new cartridge lug with label. Insert new cartridge firmly into head.</li> </ol>	 <ol style="list-style-type: none"> <li>6. Turn cartridge right 90° until rotation stops.</li> <li>7. Repeat Steps 3-6 for remaining cartridges.</li> </ol>	 <p><b>Flushing</b></p> <ol style="list-style-type: none"> <li>8. With the Manifold Rinse Valve fully open, open Manifold Inlet Valve to 1/4 open. When air is purged, open to full for five (5) minutes. Close Manifold Rinse Valve.</li> </ol>
 <p><b>HFUF Cartridge Change Only</b></p> <ol style="list-style-type: none"> <li>1. Shut off the inlet water valve ahead of system, the Tank Valve and the Manifold Inlet Valve.</li> </ol>	 <ol style="list-style-type: none"> <li>2. Open HFUF Rinse Valve to relieve pressure.</li> <li>3. Unscrew hose from bottom of housing. Catch water.</li> </ol>	 <ol style="list-style-type: none"> <li>4. Use wrench and unscrew housing. Lower housing to remove membrane. Use finger holes in the top of the HFUF to remove.</li> </ol>	 <ol style="list-style-type: none"> <li>5. Clean bowl with filtered water only; NO SPECIAL CLEANERS.</li> <li>6. Feel housing o-ring in groove. If dry, lubricate with high quality silicone lubricant.</li> </ol>	 <ol style="list-style-type: none"> <li>7. Check three (3) o-rings on the new HFUF Cartridge. Clean and lubricate with silicone grease.</li> </ol>
 <ol style="list-style-type: none"> <li>8. Place new HFUF Cartridge in housing until it seats in bottom of bowl. Screw housing into head and hand tighten.</li> </ol>	 <ol style="list-style-type: none"> <li>9. Screw hose onto the bottom of the housing.</li> <li>10. Slowly open Inlet Valve.</li> </ol>	<ol style="list-style-type: none"> <li>11. When water runs from HFUF Rinse Valve, fully open Inlet Water Valve. Press red pressure release on HFUF Housing to release trapped air.</li> <li>12. Close the HFUF Rinse Valve and perform three (3) manual flush cycles.</li> <li>13. Open HFUF rinse valve for 15 minutes.</li> <li>14. Open the Tank Valve.</li> <li>15. Rinse for 30 minutes.</li> </ol>	 <ol style="list-style-type: none"> <li>16. Close HFUF Rinse Valve and perform three (3) manual flush cycles.</li> </ol>	 <ol style="list-style-type: none"> <li>17. Slowly open Manifold Inlet Valve to full open.</li> </ol>

## REPLACEMENT PARTS

Contact your local Pentair® Everpure® Dealer for system replacement parts.

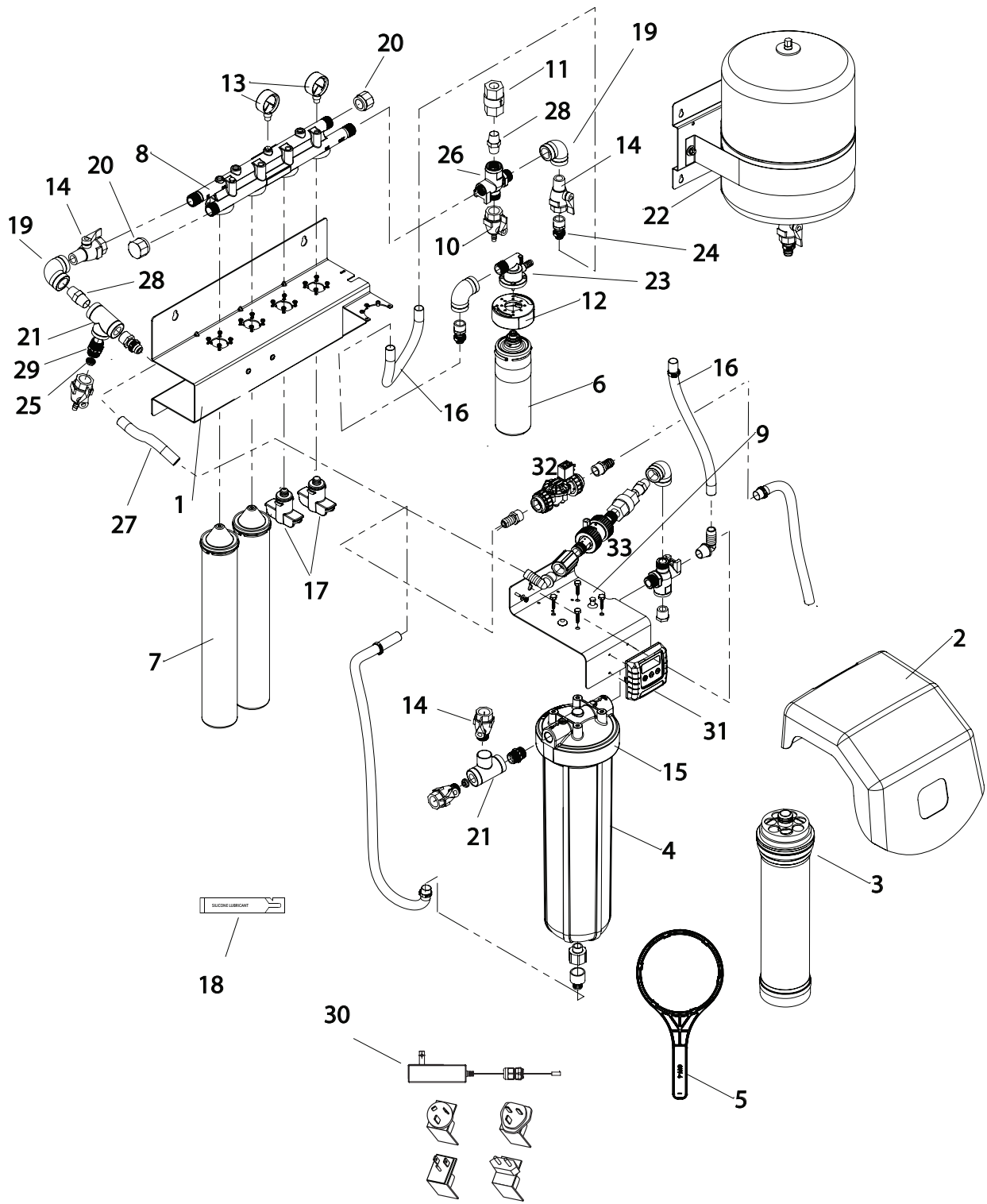

Number	Part Number	Description
1	EV313657	Bracket, Quad
2	EV314245	Shroud
3	EV962891	HFUF Cartridge
4	EV313540	Pretreatment Housing
5	SH144368	Housing Wrench
6	EV962714	2SR-BW Cartridge*
7	-----	SEN Cartridge**
8	EV311135	Manifold
9	EV313658	Bracket, Pretreatment
10	EV312248	Valve, Ball, 3/4 FNPT x 3/8 Barb
11	EV311450	Valve, Check, 3/4 NPT Female
12	EV307850	Support Ring
13	EV311409	Pressure Gauge 160 PSI
14	EV311407	Valve, Ball 3/4 FNPT x 3/4 MNPT
15	SH154198	Cap BB WH HFPP 3/4" PR MILL
16	EV313686	Tubing 3/4" ID Gray
17	EV311403	QC Plug
18	SH143495	Tube, Silicone
19	EV313604	Elbow 3/4" FNPT PVC SCH 80 SR
20	EV311134	Cap 3/4" NPT for O.P.M
21	EV310055	Tee, 3/4 NPT, SS Reinforced
22	EV313667	Tank, RO-4, 3/4" NPT Mounted
23	EV313470	Head BW, 3/4 MNPT x 1/2 Barb
24	EV305783	Barb, 3/4" NPT x 3/4" Hose, Nylon
25	EV314286	Flow Regulator
26	EV311133	Universal Fitting w/Ret-Ring
27	EV313686	Tubing 3/4" ID, Gray
28	EV309977	Hex Nipple 3/4"
29	EV314135	Nipple, 3/4" MNPT, Machined
30	43445	Power Supply with Adapters
31	4002956	Controller
32	EV313665 EV314145	Solenoid Valve Solenoid Cable
33	61823 1266722	Turbine Kit 3/4" Turbine Cable

\*Also available in replacement kits.

\*\*Only available in replacement kits.

Kit P/N	Description	Cartridge		
		HFUF Pretreatment	SEN	2SR-BW
EV962880	Twin Endurance® Cartridge Kit	0	2	1
EV962881	Triple Endurance Cartridge Kit	0	3	1
EV962882	Quad Endurance Cartridge Kit	0	4	1
EV962891	Endurance SC HFUF Cartridge	1	0	0

### CARTRIDGE CHANGE DETERMINATION

Replace all the Everpure® SEN Filter Cartridges when capacity is reached or if flow becomes inadequate, but at least annually. The cartridges on multiple cartridge systems, including the Everpure® 2SR-BW Scale Inhibitor Cartridge, should be changed at the same time.

**CAUTION: If the flow has decreased it is likely that the HFUF Cartridge is damaged.**

The HFUF Cartridge should be changed every three (3) years.

The system pressure gauges provide a means to read system pressures. The left gauge will show water pressure in front of the SEN Filter Cartridges. The second (right) gauge shows water pressure after the SEN Cartridges and going to the applications. The difference between the two pressures is an indication of the pressure drop through the SEN Cartridges. A large drop in pressure will be caused by plugged SEN Cartridges. In this case, the SEN and HFUF Cartridges should be changed.

**NOTE: If visible particles are on the top surface of the HFUF, these could lead to plugging or damage to the hollow fibers. Use a screen or pleated filter to prevent these particles from entering the HFUF pretreatment.**



System Tested and Certified by NSF International against NSF/ANSI Standards 42 and 53 for the reduction of the claims specified on the Performance Data Sheet and at [www.nsf.org](http://www.nsf.org).

## TROUBLESHOOTING

Symptom	Possible Causes	Remedies
No flow to hollow fiber.	Inlet Valve closed.	Open Inlet Valve; check water supply to system.
	Inlet flow control plugged.	Turn off water supply to system. Depressurize system. Remove inlet hose and use light to check flow control for debris. If not visible, remove hex nipple after Inlet Valve and see if inlet flow control is plugged. Use 100 micron inlet screen to prevent in future.
No flow to flush tank.	Tank Valve closed.	Open Tank Valve.
	Tank precharge is too high.	Make sure precharge is at 20 psi (1.37 bar).
No flow to cartridge manifold.	Manifold Inlet Valve is closed.	Check if Manifold Inlet Valve is open.
	Scale Inhibitor Valve or Inlet Valve closed.	Check if Scale Inhibitor Valve and any downstream valves are open. Check Outlet Check Valve for obstruction.
No flow to drinks.	Manifold Valves closed.	Check if Inlet, Manifold Valves are open.
	Inlet Valve closed or Flush Valves open. Damaged valve.	Open Inlet Valve and close Flush Valves.
No flow to hot beverages or ice machines.	Scale Inhibitor Inlet Valve closed.	Check if Inlet, Manifold and Scale Inhibitor Valves are open.
	Additional valves closed downstream.	Check rest of plumbing to equipment.
Low flow to hollow fiber.	Inlet Valve closed.	Open Inlet Valve.
	Inlet flow control plugged.	Remove inlet hose and use light to check flow control for debris. If not visible, remove hex nipple after Inlet Valve and see if inlet flow control is plugged. Use 100 micron inlet screen to prevent in future.
Low flow to flush tank or cartridge manifold.	Tank Valve closed.	Open Tank Valve.
	HFUF Cartridge is plugged and at the end of it's service life.	If HFUF is less than three (3) years old, contact Technical Support. If HFUF is more than three (3) years old, it should be replaced.
	Inlet pores of HFUF are plugged with sediment or biological growth.	Unscrew HFUF Housing and inspect top of HFUF Cartridge for large particles or slime blocking inlet pores. Do not remove the HFUF Cartridge from the housing. Clean with filtered water stream. If still visibly blocked, replace module and install screen filter before inlet to trap larger particles. If not blocked, reinstall and complete HFUF sanitization procedure. Check flow again. If still low, replace HFUF and contact Technical Support for additional recommendations.
Low flow to cartridge manifold.	Cartridge Manifold Valve not fully open.	Open Cartridge Manifold Valve.
Low flow to drinks.	SEN Cartridges plugged.	Check pressure drop with Manifold Flushing Valve open at approximately 3-4 gpm (11.3-15.1 Lpm). If the difference between the cartridge pressure gauges exceed 30 psid (2.0 bar), replace cartridges. Contact Technical Support.
	SEN Cartridges plugged, HFUF needs to be replaced.	If cartridges do not last stated life or one year, then the HFUF could be damaged and needs to be replaced. Contact Technical Support.
	Low pressure to system.	Check inlet pressure to system. Inlet pressure should be 50 psi (3.4 bar) or greater.
Low flow to hot beverages or ice machines.	Scale Inhibitor Valve partially closed.	Open Scale Inhibitor Valve.
Controller will not program correctly.	Controller programing or instructions incorrect.	Contact Technical Support.
	Controller damaged.	Contact Technical Support.

Symptom	Possible Causes	Remedies
Controller does not display readings.	Power outlet does not work or unit not plugged in.	Plug in power supply and check outlet for power with appropriate tester.
	Power connector to board loose.	Remove cover with three (3) back side tabs and check lower right power connection.
	Power supply not functioning.	Check plug attachment on power supply. Check power to board for 24 VDC by removing three (3) back tabs on controller and testing lower right two (2) power pins on board.
	Controller damaged.	Contact Technical Support.
Controller does not count down time between default flush cycle (TR) in hours and minutes.	Controller damaged.	Contact Technical Support.
Controller does not display flow (FR) or count down gallons to backflush (VR) when water is flowing.	Sensor cable not connected.	Plug in sensor cable to flow meter. Change display to scroll.
	Turbine is stuck.	Disconnect union fittings and see if turbine spins freely. If not, contact Technical Support.
	Sensor cable not connected.	Turbine cable is not connected to back of controller. The four (4) screws holding the controller to the bracket may need to be removed to get access to the plug location.
Water runs to drain for four (4) seconds, stops and repeats.	Controller malfunction.	Contact Technical Support.
Water runs continuously to drain.	Solenoid or controller malfunction.	Check that the backflush time is set to four (4) seconds. The program setting should be PRG4. See "Setting The Controller For Normal Operation" on page 10. See if a paper clip can be held in place by the active solenoid magnet. If paper clip falls, solenoid needs to be replaced. If the paper clip stays attached for more than four (4) seconds, controller will need to be replaced.
System does not backflush.	Turbine not functioning or not reading.	See: Controller does not display flow (FR) or count down gallons to backflush (VR).
	Solenoid cable not connected.	Remove solenoid cable and measure for 24 VDC output during manually initiated flush.
	Solenoid cable not connected.	Remove controller from bracket and check if solenoid is plugged into board. May also need to remove front cover with three (3) front cover tabs.
	Solenoid not functioning.	Replace solenoid.
	Undefined problem.	Contact Technical Support.
Union fittings on water meter or solenoid leak.	Loose union fittings.	Tighten union fittings. Verify o-rings are in place and not damaged.
HFUF housing leaks.	Missing or pinched o-ring.	Remove pressure. Loosen housing and check if o-ring is lubricated and in the housing groove.
	Housing not tightened.	Tighten housing by hand. If it still leaks, use a wrench and turn just enough to stop leak.
	Flush coupling on bottom missing o-ring or not tightened.	Depressurize system. Check coupling for o-ring and hand tighten.
Solenoid leaks.	Loose screws or bad seal.	Tighten screws. Contact Technical Support if not fixed.



<b>Symptom</b>	<b>Possible Causes</b>	<b>Remedies</b>
SEN or 2SR-BW Cartridges leak.	Poor cartridge o-ring seal and head seal.	Depressurize the system and remove the leaking cartridge. Check to make sure o-rings are in place, undamaged and clean of debris. Also, check the internal head surface for debris or, a damaged sealing surface. Lubricate o-rings and install the cartridge. Check for leaks. If cartridge continues to leak, replace with new cartridge and contact Technical Support.
Tank precharge less than 20 psi (1.37 bar).	No pressure from factory, as shipped.	Add 20 psi (1.37 bar) precharge.
	Slow precharge leak.	Add 20 psi (1.37 bar) precharge and check for slow leak over several days or weeks. Make sure controller is set to four (4) second flush. Tank must be installed with outlet port down. Contact Technical Support. Replace tank.



# LIMITED WARRANTY

## COMMERCIAL WATER TREATMENT EQUIPMENT

You have just purchased one of the finest water treatment units made. As an expression of confidence in this product, Pentair Filtration Solutions, LLC ("PFS") offers the following product warranty. This product is warranted against material defects in materials and workmanship to the original end-user when installed in accordance with the PFS specifications. The warranty period commences on the date of purchase and is administered as follows:

**For a period of ONE YEAR Replaceable elements (i.e., filter & water treatment cartridges)\***

**For a period of FIVE YEARS The entire system (excluding replaceable elements)**

The unit must be used in operating conditions that conform to PFS's recommended guidelines. This warranty will not apply if the unit has been modified, repaired or altered by someone not authorized by PFS.

If a part described above is found to have a material defect in materials or workmanship within the specified warranty period, you should notify Pentair® Everpure technical service at the phone number listed below. Any part found materially defective within the terms of this warranty will be repaired or replaced (at PFS's discretion) by your local dealer or Pentair Everpure technical service. You pay only freight from our factory and local dealer charges. Any item repaired or replaced pursuant to this warranty will be covered under the original warranty terms of the system.

PFS is not responsible for damage caused by accident, fire, flood, freezing, Act of God, misuse, misapplication, neglect, oxidizing agents (such as chlorine, ozone, chloramines and other related components), alteration, installation or operation contrary to our printed instructions, or by the use of accessories or components which do not meet PFS's specifications. Refer to the specifications section in the Installation and Operating manual for approved application parameters.

Our product performance specifications are furnished with each water treatment unit. TO THE EXTENT PERMITTED BY LAW, EVERPURE DISCLAIMS ALL IMPLIED WARRANTIES, INCLUDING WITHOUT LIMITATION WARRANTIES OF MERCHANTABILITY AND FITNESS FOR PARTICULAR PURPOSE; TO THE EXTENT REQUIRED BY LAW, ANY SUCH IMPLIED WARRANTIES ARE LIMITED IN DURATION TO THE PERIOD SPECIFIED ABOVE FOR THE ENTIRE WATER TREATMENT UNIT.

As a manufacturer, we do not know the characteristics of your water supply or the purpose for which you are purchasing this product. The quality of water supplies may vary seasonally or over a period of time, and your water usage rate may vary as well. Water characteristics can also differ considerably if this product is moved to a new location. For these reasons, we assume no liability for the determination of the proper equipment necessary to meet your requirements, and we do not authorize others to assume such obligations for us. Further, we assume no liability and extend no warranties, express or implied, for the use of this product with a non-potable water source or a water source which does not meet the conditions for use described in the owner's guide or performance data sheet for this product.

OUR OBLIGATIONS UNDER THIS WARRANTY ARE LIMITED TO THE REPAIR OR REPLACEMENT (AT PFS'S DISCRETION) OF THE FAILED PARTS OF THE WATER TREATMENT UNIT, AND WE ASSUME NO LIABILITY WHATSOEVER FOR DIRECT, INDIRECT, INCIDENTAL, CONSEQUENTIAL, SPECIAL, GENERAL OR OTHER DAMAGES.

Some states do not allow the exclusion of implied warranties or limitations on how long an implied warranty lasts, so the above limitation may not apply to you. Similarly, some states do not allow the exclusion of incidental or consequential damages, so the above limitation or exclusion may not apply to you. This warranty gives you specific legal rights, and you may also have other rights which vary from state to state.

\*Warranty applies to material defects in materials & workmanship only.

### **Pentair Filtration Solutions, LLC.**

1040 Muirfield Drive  
Hanover Park, IL 60133  
United States  
Pentair Everpure Technical Service:  
800.942.1153 / 630.307.3000



#### **FILTRATION & PROCESSING SOLUTIONS**

EVERPURE-SHURFLO WORLD HEADQUARTERS, 1040 MUIRFIELD DRIVE, HANOVER PARK, IL 60133 USA • WWW.EVERPURE.COM  
800.942.1153 MAIN (US ONLY) • 800.942.1153 (US ONLY) • 630.307.3000 MAIN • 630.307.3030 FAX • CSEVERPURE@PENTAIR.COM EMAIL

PENTAIR AUSTRALIA/NEW ZEALAND, 1-21 MONASH DRIVE, DANDENONG SOUTH, VIC 3175, AUSTRALIA  
1300.576.190 TEL • AU.EVERPURE@PENTAIR.COM EMAIL

EVERPURE-SHURFLO CHINA, 21F CLOUD 9 PLAZA, NO 1118, SHANGHAI, 200052, CHINA  
86.21.3211.4588 TEL • 86.21.3211.4580 FAX • CHINA.WATER@PENTAIR.COM EMAIL

EVERPURE-SHURFLO INDIA, GREEN BOULEVARD, B-9/A, 7TH FLOOR - TOWER B SECTOR 62, NOIDA - 201301  
91.120.419.9444 TEL • 91.120.419.9400 FAX • INDIACUSTOMER@PENTAIR.COM EMAIL

EVERPURE-SHURFLO EUROPE, PENTAIR WATER BELGIUM BVBA, INDUSTRIEPARK WOLFSTEE, TOEKOMSTLAAN, 30 B-2200 HERENTALS, BELGIUM  
+32.(0).14.283.500 TEL • +32.(0).14.283.505 FAX • SALES@EVERPURE-EUROPE.COM EMAIL

EVERPURE-SHURFLO JAPAN INC., HASHIMOTO MN BLDG. 7F, 3-25-1 HASHIMOTO, MIDORI-KU, SAGAMIHARA-SHI KANAGAWA 252-0143, JAPAN  
81.(0)42.775.3011 TEL • 81.(0)42.775.3015 FAX • INFO@EVERPURE.CO.JP EMAIL

EVERPURE-SHURFLO SOUTHEAST ASIA, 390 HAVELOCK ROAD, #04-01, KING'S CENTRE, SINGAPORE 169662  
65.6795.2213 TEL • FAX: 65.6795.2219 FAX • CSEVERPURE@PENTAIR.COM EMAIL

All Pentair trademarks and logos are owned by Pentair, Inc. or its affiliates. All other registered and unregistered trademarks and logos are the property of their respective owners. Because we are continuously improving our products and services, Pentair reserves the right to change specifications without prior notice. Pentair is an equal opportunity employer.

© 2014 Pentair Filtration Solutions, LLC. All Rights Reserved.

EV313749 Rev A SE14