

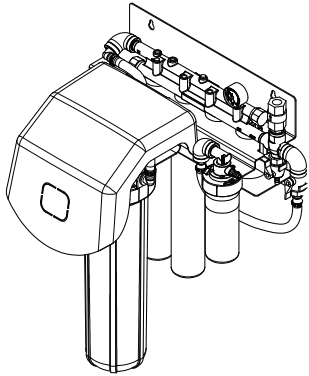

EVERPURE® ENDURANCE™ HIGH FLOW WATER FILTER SYSTEM

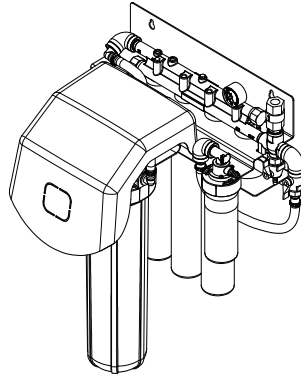

Twin System



Triple System

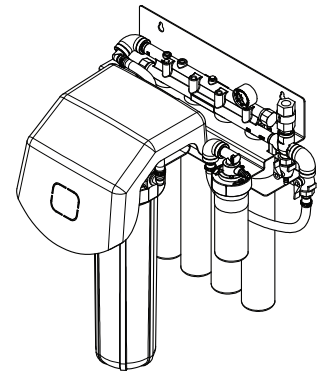

Quad System

INTRODUCTION

The Everpure Endurance™ High Flow water filter system is designed to treat up to 200,000 gallons of water per year. The system uses a pretreatment filter, 2, 3 or 4 fine cartridges and a scale inhibiting cartridge.

INSPECTION

Before mounting the Endurance system, inspect the parts. Use the table and illustration to verify the parts and quantities. If any parts are missing, contact Customer Service at 630.307.3000 or by email at CSeverpure@pentair.com.

| Parts | Twin | Triple | Quad |
|-----------------------------------|------|--------|------|
| 1. Manifold with Bracket | 1 | 1 | 1 |
| 2. Shroud | 1 | 1 | 1 |
| 3. Pleated Endurance HF Cartridge | 1 | 1 | 1 |
| 4. Pretreatment Housing | 1 | 1 | 1 |
| 5. Housing Wrench | 1 | 1 | 1 |
| 6. ZSR-BW Cartridge | 1 | 1 | 1 |
| 7. SEN Cartridge | 2 | 3 | 4 |
| 8. Port Plug | 2 | 1 | 0 |

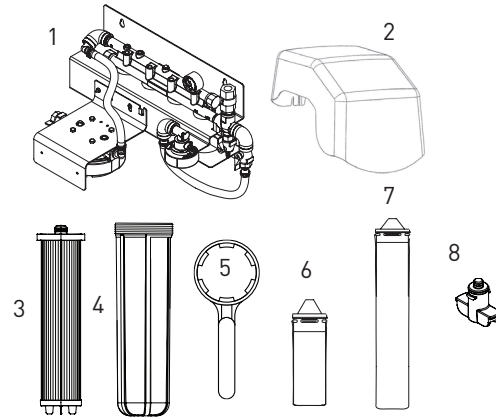

SELECTING A LOCATION

The location selected for system installation should allow for:

- Adequate space for “in” and “out” water line connections.
- Mounting screws should anchor into a solid structure.
- The frame is designed to mount on 16 inch centers (wall studs).
- Allow 5 inches below the cartridges for removal.
- The pretreatment housing can be removed from the frame and mounted separately. Be certain to use adequate lengths of opaque beverage tubing.
- Give consideration to the weight of the system when filled with water. Operating weights of the Endurance system are:
 High Flow Twin System - 58.4 lbs. (26.5 kg)
 High Flow Triple System - 63.8 lbs. (28.9 kg)
 High Flow Quad System - 69.1 lbs. (31.3 kg)

OPERATING SPECIFICATIONS

- Temperature Limits: 35-100°F (2-38°C)
- Pressure Limits: 10-100 psi (0.689-6.9 bar)
- For cold water use only.
- Rated Service Flow:
 - Endurance High Flow Twin System - 7.5 gpm (28.4 lpm)
 - Endurance High Flow Triple System - 11.25 gpm (42.6 lpm)
 - Endurance High Flow Quad System - 15 gpm (56.8 lpm)
- Service Life Between Cartridge Changes:
 - Endurance High Flow Twin System - 100,000 gal (378,541 liters) or 1 year
 - Endurance High Flow Triple System - 150,000 gal (567,812 liters) or 1 year
 - Endurance High Flow Quad System - 200,000 gal (757,082 liters) or 1 year

DIMENSIONS

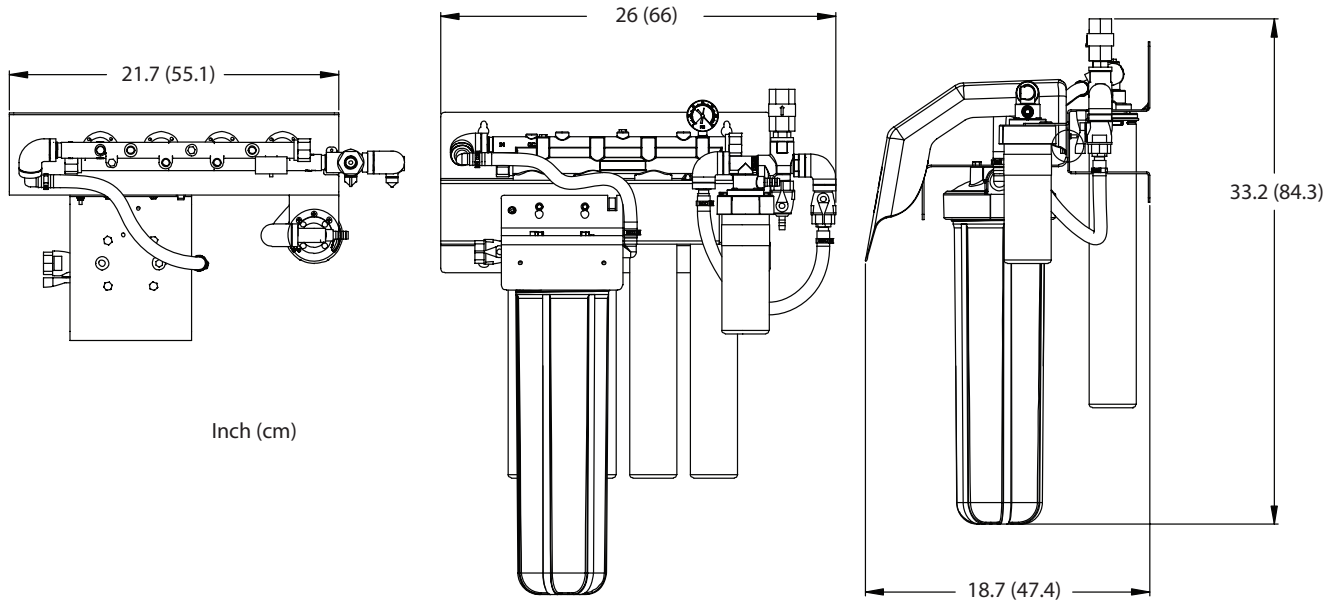

INSTALLATION INSTRUCTIONS

1. The predrilled mounting holes in the bracket can be used as a guide. The holes are on 16 inch centers. Mark and insert anchors or screws in the wall.

NOTE: The large pretreatment cartridge can be removed from the bracket and mounted separately.

2. Follow steps 3-6 only if the pretreatment cartridge (Pleated Endurance HF) is going to be mounted separately. Otherwise proceed to Step 7.
3. Disconnect the hose between pretreatment head and the manifold.

4. Unscrew the two screws that hold the pretreatment bracket to the main bracket.

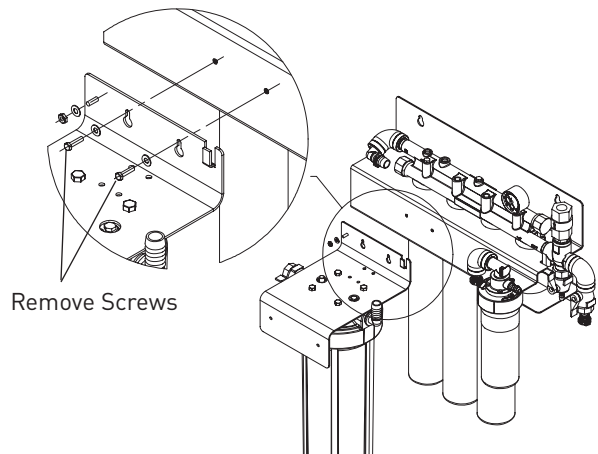

Figure 1

5. Secure the pretreatment bracket with head to the desired location. Use the screw holes from the previous step for mounting.
6. Use a section of 3/4-inch I.D. tubing to reconnect the pretreatment outlet to the inlet of the manifold. The pretreatment outlet cannot be more than 25 feet from the manifold. The tubing should be held with clamps at each end with no sharp bends or kinks.

NOTE: Use tubing that is opaque and suitable for use with beverages.

7. Mount the manifold using four screws in the bracket mounting holes.
8. Connect the treated water outlet port to the equipment being served (Figure 2).

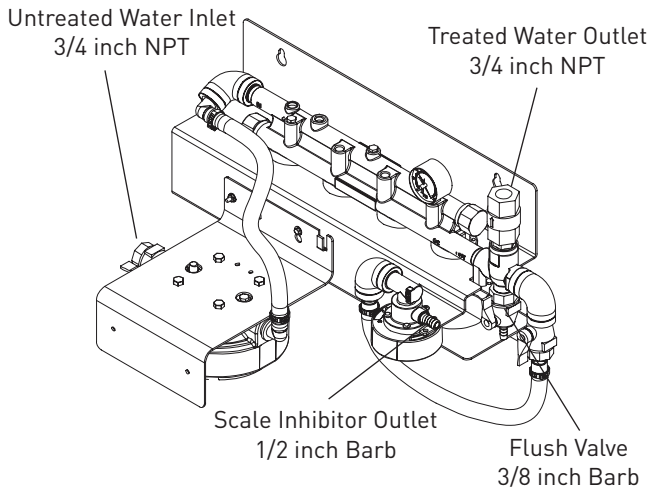

Figure 2

9. Connect the untreated water to the inlet fitting on the pretreatment head (Figure 2).
10. Attach 3/8 inch I.D. tubing to the flush valve fitting (Figure 2). Run the other end of the tubing to a drain.

NOTE: Some plumbing codes require an air gap at the drain termination.

FLUSHING

For maximum life, all carbon filter cartridges must be flushed for five minutes at full flow before use. ALL NEW CARTRIDGES MUST BE FLUSHED AFTER EACH CARTRIDGE CHANGE BEFORE BEING PUT INTO SERVICE!

If the cartridges are new, have been properly flushed and the pressure gauge needle registers inadequate pressure, you may be experiencing inadequate water pressure or some restriction may exist in the inlet water line. In either case, the incoming water pressure must be improved to receive optimum filter life.

Not for residential use. For food service applications only.

Check for compliance with state and local laws and regulations. Do not use with water that is microbiologically unsafe or of unknown quality without adequate disinfection before or after the system. Systems certified for cyst reduction may be used on disinfected waters that may contain filterable cysts.

The term "bacteriostatic" indicates that the system limits the passage or growth of bacteria that may already exist in the incoming water. It does not mean that the water leaving the system is safer to drink than the water entering the system.

11. The 2SR-BW does not have a shut off valve. Attach 1/2 inch I.D. tubing to the outlet barb of the 2SR-BW head. Route the other end of the tubing to the equipment being served. Both ends of the tubing should be clamped to the hose barb.
12. Turn off the flow valves for the inlet, flush and scale inhibitor cartridge (2SR-BW)(Figure 2).
13. Check to be sure the o-ring on the pretreatment housing is sufficiently lubricated. Use a good grade of silicone lubricant, if needed. Unwrap the pretreatment cartridge. Position the pretreatment cartridge on guide seat in the bottom of the bowl. Then thread the bowl into the head by hand. Use a sump wrench to lightly tighten the bowl onto the head. This bowl can be tightened further if leaks occur later. The two o-rings at the top of the cartridge will fit snugly into the head.

NOTE: To install the carbon filter and scale inhibitor cartridges, align the cartridge lug with the label, push upward and rotate to the right (cw) until rotation stops.

14. Install only genuine Everpure™ carbon filter cartridge(s) into the filter head(s) following directions on the SEN cartridge label or as shown in the Cartridge Change Procedure illustrations. Install the scale inhibitor cartridge (2SR-BW).

CAUTION: Unused manifold ports must be plugged. Any ports that are not plugged will leak.

15. Open the flush valve then turn on the inlet water. Open the valve on the pretreatment head. Water will flush to the drain at full force. Allow the system to flush for five minutes. This will set the filtering media and purge any air.
16. After flushing, close the flushing valve. The pressure gauge will show the system pressure when the cartridges are new.
17. Open the valve for the scale inhibitor cartridge. The Endurance High Flow system is now ready for use.

CARTRIDGE CHANGE DETERMINATION

Replace all the filter cartridges when capacity is reached or when flow becomes inadequate, but at least annually. All cartridges on multiple cartridge systems should be changed at the same time.

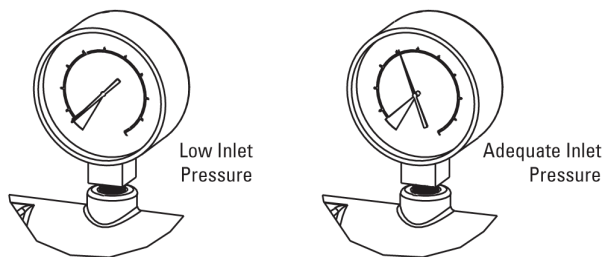

The system pressure gauge provides a quick, simple means of determining when the filter cartridge(s) should be checked. It is installed on the system outlet manifold. The gauge can be used to monitor both dynamic (flowing) and static (line) pressure. The cartridge(s) should be changed when the pressure gauge is in the red area while equipment is in operation, and the needle shows adequate line pressure between cycles. Observe the needle during the next equipment on cycle. If the needle registers adequate pressure, it can be assumed that the temporary low-pressure condition was caused by a brief power failure or other incoming pressure disruption. If the low pressure condition is not due to an external condition, check/change the pretreatment filter first. If the low pressure condition is still not corrected, change the SEN carbon filter cartridges.

PRESSURE GAUGES

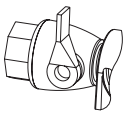
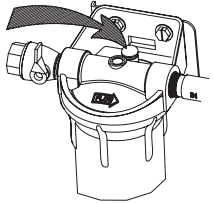
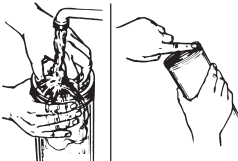
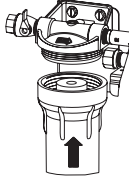

CARTRIDGE CHANGE PROCEDURE

Place a pan below the cartridges to catch any water when removing cartridges. Inlet water must be turned off.

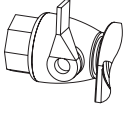
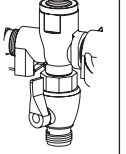
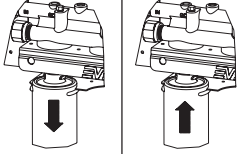
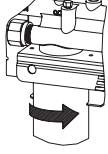
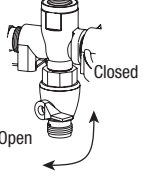
| | | | | |
|---|--|---|--|--|
|  <p>Pretreatment Cartridge Change</p> <ol style="list-style-type: none"> 1. Shut off inlet water ahead of system. |  <ol style="list-style-type: none"> 2. Remove shroud. 3. Push red relief valve. Unscrew bowl. Remove pretreatment filter cartridge. |  <ol style="list-style-type: none"> 4. Clean bowl with filtered water only; NO SPECIAL CLEANERS. 5. Feel head o-ring. If dry, lubricate with high quality silicone lubricant. |  <ol style="list-style-type: none"> 6. Install new pretreatment filter cartridge in bowl. Hand tighten bowl onto head. |  <ol style="list-style-type: none"> 7. With flushing valve fully open, open inlet water at full force for five minutes. Close flushing valve. |
|  <p>Everpure SEN Carbon Filter and 2SR-BW Scale Inhibitor Cartridge Change</p> <ol style="list-style-type: none"> 1. Shut off inlet water ahead of system. |  <ol style="list-style-type: none"> 2. Open flushing valve to relieve pressure. 3. Hold head firmly and push upward. Turn cartridge to left until it stops. |  <ol style="list-style-type: none"> 4. Pull cartridge downward and out of head. 5. Hold head firmly. Align cartridge lug with label. Insert new cartridge firmly into head. |  <ol style="list-style-type: none"> 6. Turn cartridge right 90° until rotation stops. 7. Repeat steps 3-6 for remaining cartridges. |  <p>Flushing</p> <ol style="list-style-type: none"> 8. With flushing valve fully open, open inlet water at full force for five minutes. Close flushing valve. |

For installations in Massachusetts, the Commonwealth of Massachusetts Plumbing Code 248 CMR shall be adhered to. Consult your licensed plumber for installation of the system. This system and its installation must comply with state and local regulations.



System Tested and Certified by NSF International against NSF/ANSI Standard 42 and 53 for the reduction of:

**Standard No. 42 —
Aesthetic Effects**

Bacteriostatic Effects
Chemical Reduction
Taste and Odor
Chlorine
Mechanical Filtration
Nominal Particulate Class 1

**Standard No. 53 —
Health Effects**

Mechanical Filtration
Turbidity
Cyst

REPLACEMENT PARTS

Contact your local Everpure dealer for system replacement parts.

| Number | Part Number | Description |
|--------|-------------|----------------------------------|
| 1 | EV313657 | Bracket, Quad |
| 2 | EV313659 | Shroud |
| 3 | | Pleated Endurance HF Cartridge* |
| 4 | 153087 | Pretreatment Housing |
| 5 | 144368 | Housing Wrench |
| 6 | EV962714 | 2SR-BW Cartridge |
| 7 | | SEN Cartridge * |
| 8 | EV311135 | Manifold |
| 9 | EV313658 | Bracket, Pretreatment |
| 10 | EV312248 | Valve, Ball, 3/4 FNPT x 3/8 Barb |
| 11 | EV311450 | Valve, Check, 3/4 NPT Female |
| 12 | EV313470 | Head BW, 3/4 MNPT x 1/2 Barb |
| 13 | EV311409 | Pressure Gauge 160 PSI |
| 14 | EV311407 | Valve, Ball 3/4 FNPT x 3/4 MNPT |
| 15 | 154198 | Cap BB WH HFPP 3/4" PR MILL |
| 16 | EV313686 | Tubing 3/4" ID Gray |
| 17 | EV310876 | Bypass Plug |

| Kit P/N | Description | Cartridge | | |
|----------|--------------------------------|---------------|-----|--------|
| | | Pre-Treatment | SEN | 2SR-BW |
| EV962870 | Twin Endurance Cartridge Kit | 1 | 2 | 1 |
| EV962871 | Triple Endurance Cartridge Kit | 1 | 3 | 1 |
| EV962872 | Quad Endurance Cartridge Kit | 1 | 4 | 1 |

* Only available in replacement kits.

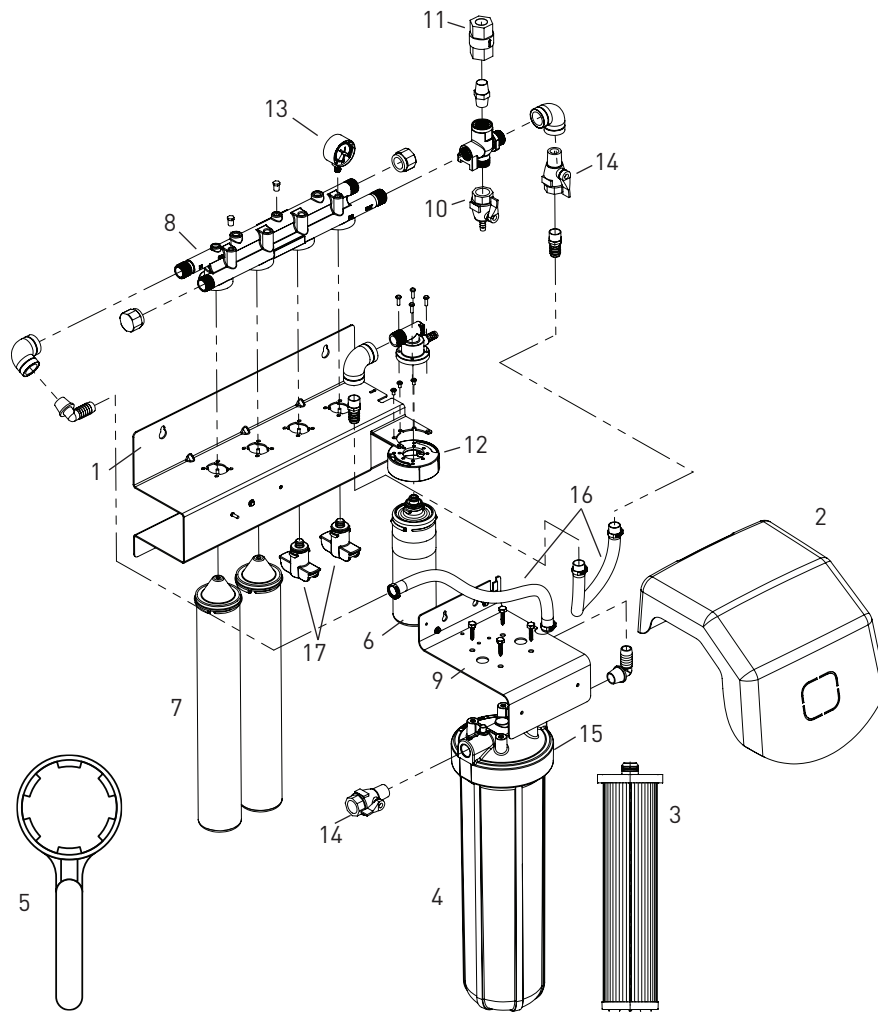

LIMITED WARRANTY

COMMERCIAL WATER TREATMENT EQUIPMENT

You have just purchased one of the finest water treatment units made. As an expression of our confidence in Everpure products, this product is warranted against defects in material and workmanship to the original end-user when installed in accordance with Everpure specifications. The warranty period commences from the date of purchase and is administered as follows:

For a period of ONE YEAR **Replaceable elements (i.e., filter & water treatment cartridges)***

For a period of FIVE YEARS **The entire system (excluding replaceable elements)**

***This is for material & workmanship, not filter or water treatment cartridge life.**

The unit must be used in operating conditions that conform to Everpure's recommended design guidelines. This warranty will not apply if the unit has been modified, repaired or altered by someone not authorized by Everpure.

If a part described above is found defective within the specified period, you should notify Everpure technical service at the phone number listed below. Any part found defective within the terms of this warranty will be repaired or replaced (at Everpure's discretion) by your local dealer or Everpure technical service. You pay only freight from our factory and local dealer charges. Any repaired or replaced warranty item will be incorporated under the original warranty terms of the existing system.

We are not responsible for damage caused by accident, fire, flood, freezing, Act of God, misuse, misapplication, neglect, oxidizing agents (such as chlorine, ozone, chloramines and other related components), alteration, installation or operation contrary to our printed instructions, or by the use of accessories or components which do not meet Everpure's specifications. Refer to the specifications section in the Installation and Operating manual for approved application parameters.

Our product performance specifications are furnished with each water treatment unit. TO THE EXTENT PERMITTED BY LAW, EVERPURE DISCLAIMS ALL IMPLIED WARRANTIES, INCLUDING WITHOUT LIMITATION WARRANTIES OF MERCHANTABILITY AND FITNESS FOR PARTICULAR PURPOSE; TO THE EXTENT REQUIRED BY LAW, ANY SUCH IMPLIED WARRANTIES ARE LIMITED IN DURATION TO THE PERIOD SPECIFIED ABOVE FOR THE ENTIRE WATER TREATMENT UNIT. As a manufacturer, we do not know the characteristics of your water supply or the purpose for which you are purchasing this product. The quality of water supplies may vary seasonally or over a period of time, and your water usage rate may vary as well. Water characteristics can also differ considerably if this product is moved to a new location. For these reasons, we assume no liability for the determination of the proper equipment necessary to meet your requirements, and we do not authorize others to assume such obligations for us. Further, we assume no liability and extend no warranties, express or implied, for the use of this product with a non-potable water source or a water source which does not meet the conditions for use described in the owner's guide or performance data sheet for this product. OUR OBLIGATIONS UNDER THIS WARRANTY ARE LIMITED TO THE REPAIR OR REPLACEMENT (AT EVERPURE'S DISCRETION) OF THE FAILED PARTS OF THE WATER TREATMENT UNIT, AND WE ASSUME NO LIABILITY WHATSOEVER FOR DIRECT, INDIRECT, INCIDENTAL, CONSEQUENTIAL, SPECIAL, GENERAL OR OTHER DAMAGES.

Some states do not allow the exclusion of implied warranties or limitations on how long an implied warranty lasts, so the above limitation may not apply to you. Similarly, some states do not allow the exclusion of incidental or consequential damages, so the above limitation or exclusion may not apply to you. This warranty gives you specific legal rights, and you may also have other rights which vary from state to state. Consult your telephone directory for your local independently operated Everpure dealer, or write Everpure for warranty and service information.



WATER SOLUTIONS

EVERPURE-SHURFLO WORLD HEADQUARTERS, 1040 MUIRFIELD DRIVE, HANOVER PARK, IL 60133 USA • WWW.EVERPURE.COM
800.942.1153 MAIN (US ONLY) • 800.942.1153 (US ONLY) • 630.307.3000 MAIN • 630.307.3030 FAX • CSEVERPURE@PENTAIR.COM EMAIL

PENTAIR AUSTRALIA/NEW ZEALAND, 1-21 MONASH DRIVE, DANDENONG SOUTH, VIC 3175, AUSTRALIA
1300.576.190 TEL • AU.EVERPURE@PENTAIR.COM EMAIL

EVERPURE-SHURFLO CHINA, 21F CLOUD 9 PLAZA, NO 1118, SHANGHAI, 200052, CHINA
86.21.3211.4588 TEL • 86.21.3211.4580 FAX • CHINA.WATER@PENTAIR.COM EMAIL

EVERPURE-SHURFLO INDIA, GREEN BOULEVARD, B-9/A, 7TH FLOOR - TOWER B SECTOR 62, NOIDA - 201301
91.120.419.9444 TEL • 91.120.419.9400 FAX • INDIACUSTOMER@PENTAIR.COM EMAIL

EVERPURE-SHURFLO EUROPE, PENTAIR WATER BELGIUM BVBA, INDUSTRIEPARK WOLFSTEE, TOEKOMSTLAAN, 30 B-2200 HERENTALS, BELGIUM
+32.(0).14.283.500 TEL • +32.(0).14.283.505 FAX • SALES@EVERPURE-EUROPE.COM EMAIL

EVERPURE-SHURFLO JAPAN INC., HASHIMOTO MN BLDG. 7F, 3-25-1 HASHIMOTO, MIDORI-KU, SAGAMIHARA-SHI KANAGAWA 252-0143, JAPAN
81.(0)42.775.3011 TEL • 81.(0)42.775.3015 FAX • INFO@EVERPURE.CO.JP EMAIL

EVERPURE-SHURFLO SOUTHEAST ASIA, 18 BOON LAY WAY, #04-110/111, TRADEHUB 21, 609966, SINGAPORE
65.6795.2213 TEL • FAX: 65.6795.2219 FAX • CSEVERPURE@PENTAIR.COM EMAIL

All Pentair trademarks and logos are owned by Pentair, Inc. All other brand or product names are trademarks or registered marks of their respective owners. Because we are continuously improving our products and services, Pentair reserves the right to change specifications without prior notice.

Pentair is an equal opportunity employer.

© 2012 Pentair Filtration Solutions, LLC. All Rights Reserved.

EV313748 Rev A N012