



EVERPURE® CB20-302E WATER FILTER EV9100-32

HIGH FLOW, HIGH CAPACITY CARBON FILTER FOR CHLORINE AND CHLORAMINE REDUCTION

CB20-302E System: EV9100-32
302 Replacement Cartridge Kit: EV9105-21
Kit Contains: (1) CC1E Replacement Cartridge and
(1) CC3E Replacement Cartridge



APPLICATIONS

High-Flow, High-Volume Foodservice
Applications Requiring
Chloramine Reduction

FEATURES • BENEFITS

Improves the taste and consistency of
beverages and ice by reducing chloramine,
chlorine and other off-tastes and odors

Exclusive precoat filtration provides
superior chlorine taste & odor reduction
and micro-filters dirt and particles as small
as 0.5 micron in size by mechanical means

CC1E extended service cartridge contains
radial flow granular activated
carbon (GAC)

High pressure housing includes head with
pressure relief valve, mounting bracket
and bowl

Integral inlet and outlet pressure gauge
monitors operation

NSF/ANSI Standard 53 certified to reduce
cysts such as *Cryptosporidium* and *Giardia*
by mechanical means

INSTALLATION TIPS

Choose a mounting location which is
suitable to support the full weight of the
system when operating (30 lbs [13.6 kgs]).

3/4" FNPT inlet and outlet connection.

Install on cold water lines only.

Do not install where unit is exposed to
direct sunlight.

Allow a minimum of 4" (10.16 cm)
clearance under the filter to facilitate
cartridge change.

Do not braze or solder fittings into head.

Never use a saddle valve for connection.

OPERATION TIPS

Change cartridges on a regular six (6)
month preventative maintenance program.

Change cartridge when capacity is
reached (20,000 gals [75,700 L]) or when
flow becomes too slow.

Change cartridges when the difference
between the two pressure gauges is
greater than or equal to 20 psi (1.4 bar).

Service flow rate must not exceed
5.0 gpm (19 Lpm).

After installing CC1E Cartridge, flush at
full flow for five minutes. Install CC3E
cartridge and flush system for 10 minutes.

For coffee and ice applications, add scale
reduction feeder at outlet of system
P/N: EV9798-45.

SIZING

Service Flow Rate: Maximum 5 gpm
(19 Lpm)

Rated Capacity: 20,000 gallons (75,700 L)

EVERPURE® CB20-302E WATER FILTER

EV9100-32

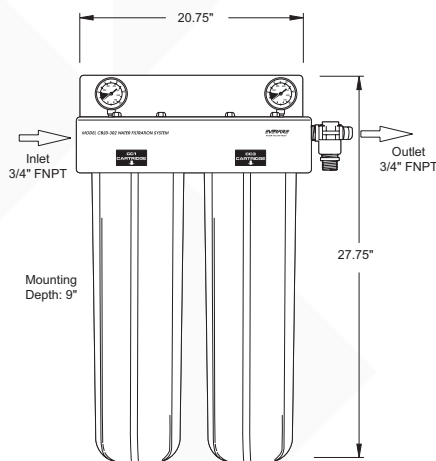

SPECIFICATIONS

Service Flow Rate

Maximum 5 gpm (19 Lpm)

Rated Capacity

20,000 gallons (75,700 L)

Pressure Requirements

20 - 100 psi (1.4 - 6.9 bar), non-shock

Overall Dimensions

27.75" H x 20.75" W x 9" D
(70.5 cm x 52.7 cm x 22.9 cm)

Inlet Connection

3/4" FNPT

Outlet Connection

3/4" FNPT

Temperature Limits

35 - 100°F (2 - 38°C)

Electrical Connection

None required

Shipping Weight

46 lbs (20.8 kgs)



System Tested and Certified by NSF International against NSF/ANSI Standards 42 and 53 for the reduction of:

STANDARD NO. 42 — AESTHETIC EFFECTS

- Chemical Reduction
- Taste & Odor
- Chlorine
- Chloramines

Mechanical Filtration
Nominal Particulate, Class I

STANDARD NO. 53— HEALTH EFFECTS

- Mechanical Filtration
- Cyst Reduction
- Turbidity Reduction

EPA No. 002623-IL-002

The contaminants or other substances removed or reduced by this drinking water system are not necessarily in your water. Do not use with water that is microbiologically unsafe or of unknown quality without adequate disinfection before or after the system. Systems certified for cyst reduction may be used with disinfected water that may contain filterable cysts.



WATER QUALITY SYSTEMS

EVERPURE-SHURFLO WORLD HEADQUARTERS, 1040 MUIRFIELD DRIVE, HANOVER PARK, IL 60133 USA • FOODSERVICE.PENTAIR.COM
800.942.1153 MAIN (US ONLY) • 630.307.3000 MAIN • 630.307.3030 FAX • CSEVERPURE@PENTAIR.COM EMAIL

EVERPURE-SHURFLO AUSTRALIA, 1-21 MONASH DRIVE, DANDENONG SOUTH, VIC 3175, AUSTRALIA
011.1300.576.190 TEL • 011.61.39.562.7237 FAX • AU.EVERPURE@PENTAIR.COM EMAIL

EVERPURE-SHURFLO CHINA, 21F CLOUD 9 PLAZA, NO 1118, SHANGHAI, 200052, CHINA
86.21.3211.4588 TEL • 86.21.3211.4580 FAX • CHINA.WATER@PENTAIR.COM EMAIL

EVERPURE-SHURFLO INDIA, GREEN BOULEVARD, B-9/A, 7TH FLOOR - TOWER B SECTOR 62, NOIDA - 201301
91.120.419.9444 TEL • 91.120.419.9400 FAX • INDIACUSTOMER@PENTAIR.COM EMAIL

EVERPURE-SHURFLO EUROPE, PENTAIR WATER BELGIUM BVBA, INDUSTRIEPARK WOLFSTEE, TOEKOMSTLAAN, 30 B-2200 HERENTALS, BELGIUM
+32.(0).14.283.500 TEL • +32.(0).14.283.505 FAX • SALES@EVERPURE-EUROPE.COM EMAIL

EVERPURE-SHURFLO JAPAN INC., HASHIMOTO MN BLDG. 7F, 3-25-1 HASHIMOTO, MIDORI-KU, SAGAMIHARA-SHI KANAGAWA 252-0143, JAPAN
81.(0)42.775.3011 TEL • 81.(0)42.775.3015 FAX • INFO@EVERPURE.CO.JP EMAIL

EVERPURE-SHURFLO SOUTHEAST ASIA, SOUTHEAST ASIA, 390 HAVELOCK ROAD, #04-01, KING'S CENTRE, SINGAPORE 169662
65.6768.5800 TEL • 65.6737.5149 FAX • CSEVERPURE@PENTAIR.COM EMAIL

All Pentair trademarks and logos are owned by Pentair, Inc. or its affiliates. All other registered and unregistered trademarks and logos are the property of their respective owners. Because we are continuously improving our products and services, Pentair reserves the right to change specifications without prior notice. Pentair is an equal opportunity employer.

WARRANTY

Everpure water treatment systems by Pentair® (excluding replaceable elements) are covered by a limited warranty against defects in material and workmanship for a period of five years after date of purchase. Everpure replaceable elements (filter cartridges and water treatment cartridges) are covered by a limited warranty against defects in material and workmanship for a period of one year after date of purchase. See printed warranty for details. Pentair will provide a copy of the warranty upon request.