



# EVERPURE® EVERPURE® 7SI INSURICE® PF SYSTEMS



Insurice PF Single 7SI System



Insurice PF Twin - 7SI System



Insurice PF Triple - 7SI System



Insurice PF Quad - 7SI System

## SELECTING A LOCATION

1. Give consideration to the weight of the unit when operating (filled with water). Operating weights of the Insurice PF Systems are:
  - Insurice PF Single - 7SI - 16 lbs (7.26 kg)
  - Insurice PF Twin - 7SI - 29 lbs (13.15 kg)
  - Insurice PF Triple - 7SI - 37 lbs (16.79 kg)
  - Insurice PF Quad - 7SI - 43 lbs (19.50 kg)
2. The location should allow for:
  - Minimum clearance of 2½" under the cartridge(s) so it can be lowered for removal and replacement.
  - Adequate space for "in" and "out" water line connections.
  - Be near a drain for flushing and near a 110V outlet if the accessory (sold separately) Everguard™ Low Pressure Alarm is used. See Step 5.

## OPERATING SPECIFICATIONS

- For cold water use only.
- Operating Temperature: 35 – 100°F (2 – 38°C)
- Min.-Max. Working Pressure: 10-125 psi (0.7-8.6 bar), non-shock
- Flow Rate:

System	Replacement Cartridge	Flow Rate	Capacity
Insurice PF Single - 7SI	7SI	3.5 gpm (13.25 Lpm)	25,000 gal. (94,635 L)*
Insurice PF Twin - 7SI	7SI	7.0 gpm (26.50 Lpm)	50,000 gal. (189,271 L)*
Insurice PF Triple - 7SI	7SI	10.5 gpm (39.75 Lpm)	75,000 gal. (283,906 L)*
Insurice Quad PF - 7SI	7SI	14.0 gpm (53.00 Lpm)	100,000 gal. (378,541 L)*

\*As tested by Everpure

## INSTALLATION INSTRUCTIONS

1. Use the predrilled mounting holes in the manifold bracket as guides. Mark and drill anchor holes. Mount securely. See Figures 1 – 4.
2. Shut off power to equipment.
3. Connect outlet port of the Insurice PF System to equipment served. Always use an NSF approved pipe dope or Teflon® tape at all connections. Use a backup wrench on all fittings while connecting to avoid excessive stress on the system components.
4. Install a manual shut-off valve leading to the system for servicing.
5. Connect minimum 3/8" water line to the Insurice PF Single System inlet. Use a minimum 1/2" for Insurice PF Twin, Triple and Quad Systems.
6. Connect tubing to flushing valve and run to drain. The cross fitting has a flushing valve installed on the bottom.

**Note:** Some municipal plumbing codes and good sanitary practices require an air gap at the drain termination point.

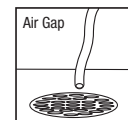

## INSTALLATION INSTRUCTIONS (continued)

7. Shut off the system inlet valve located on the inlet of the prefilter head.
8. Check to be sure the O-ring on the prefilter housing is sufficiently lubricated. Use a good grade of silicone lubricant, if needed. Position the prefilter cartridge on guide seat in the bottom of the bowl. Then thread the bowl into the head by hand. Use a sump wrench to snug the bowl onto the head.
9. Install the carbon filter cartridge(s) into the filter head(s) following directions on the cartridge label or as shown in the Cartridge Change illustrations.
10. Turn on inlet water to the filter system and check for leaks.
11. Open the flushing valve and flush the cartridge(s) by running water through at full force for ten (10) minutes. This will set the filtering media and purge any air and fines, insuring maximum filter life. See illustrations.
12. After flushing, close the flushing valve, turn on power to equipment. The system is ready for operation.

## FLUSHING

For maximum life, all carbon filter cartridges must be flushed for ten (10) minutes at full flow before use.

**ALL NEW CARTRIDGES MUST BE FLUSHED AFTER EACH CARTRIDGE CHANGE BEFORE BEING PUT INTO SERVICE!**

If the cartridges are new, have been properly flushed and both needle and follower register inadequate pressure, or the LPA is sounding, you may be experiencing inadequate water pressure or some restriction may exist in the inlet water line. In either case, the incoming water pressure must be improved to receive optimum filter life.

COMPLETE CARTRIDGE CHANGE INSTRUCTIONS CAN BE FOUND ON THE FILTER CARTRIDGE LABEL.

## CARTRIDGE CHANGE DETERMINATION

Replace the prefilter cartridge whenever it becomes excessively dirty (observed visually or by flow restriction). Follow the change instructions provided with the cartridge. Replace filter cartridges when capacity is reached, or when flow becomes inadequate, but at least annually. All filter cartridges on multiple cartridge systems should be changed at the same time. The system pressure gauge or accessory (sold separately) Everguard Low Pressure Alarm (LPA) provide a quick, simple means of determining when the filter cartridge(s) should be checked. Installed on the system outlet manifold, the gauge or LPA can be used to monitor both dynamic (flowing) and static (line) pressure. The cartridge(s) should be changed when the pressure gauge needle is in the red area while equipment is in operation, and yet the needle shows adequate line pressure between cycles. Observe the needle during the next equipment on cycle. If the needle registers adequate pressure, it can be assumed that the temporary low-pressure condition was caused by a brief power failure or other incoming pressure disruption. If the low pressure condition is not due to an external condition, check/change the prefilter first. If the low pressure condition is still not corrected, change the filter cartridges.

## REPLACEMENT PARTS

Contact your local Pentair® Everpure® Dealer for filter cartridges or system replacement parts.

Part Number	Description	Part Number	Description	Part Number	Description
System Replacement Parts					
EV3114-09	Outlet Pressure Gauge (All Systems)	EV3122-48	Insurice Twin, Triple & Quad Flush Valve	EV9606-01	7SI Replacement Cartridge 1 PK
EV3114-09	Inlet Pressure Gauge (PF Twin, Triple & Quad Flush)	EV3112-40	O-Ring for Prefilter Bowl	EV6001-07	Everguard Low Pressure Alarm 115V
EV3114-07	Inlet Valve (All Systems)	153194-06	20" Prefilter Bowl		
EV3102-01	Insurice Single PF Flush Valve	EV9534-26	20" Prefilter Replacement Cartridge 6 PK		

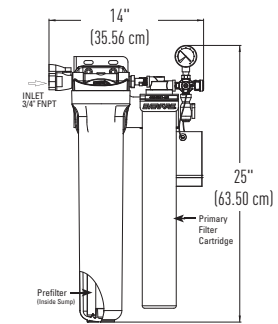

Figure 1 - Insurice PF Single - 7SI System

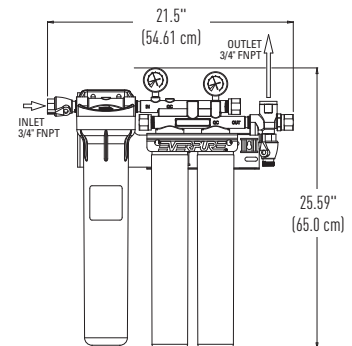

Figure 2 - Insurice Twin PF - 7SI System

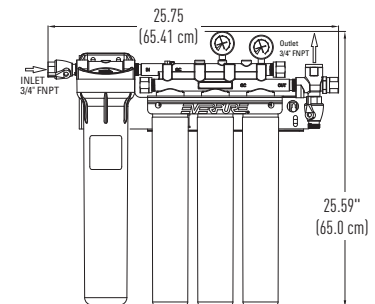

Figure 3 - Insurice Triple PF - 7SI System

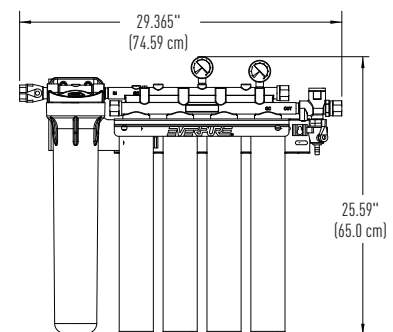

Figure 4 - Insurice Quad PF - 7SI System

**NOTES**

This installation must comply with all applicable state and local regulations.

Do not use with water that is microbiologically unsafe or of unknown quality without adequate disinfection before or after the system. Systems certified for cyst reduction may be used on waters that may contain filterable cysts.

For installations in Massachusetts, the Commonwealth of Massachusetts Plumbing Code 248 CMR shall be adhered to. Consult your licensed plumber for installation of the system. This system and its installation must comply with state and local regulations.

Not for residential use. For food service applications only.

Testing was performed under standard laboratory conditions.

Effectively filters dirt and particles as small as 1/2 micron in size by mechanical means.

NSF/ANSI Standard 53 Certified to reduce Cysts such as *Cryptosporidium* and *Giardia* by mechanical means.

EPA Est. No. 002623-IL-002.



Insurice PF 7SI systems are Tested and Certified by NSF International against NSF/ANSI Standard 42 and 53 for the reduction of:

STANDARD NO. 42 – AESTHETIC EFFECTS

Mechanical Filtration  
Nominal Particulate Class I

STANDARD NO. 53 – HEALTH EFFECTS

Mechanical Filtration  
Cyst

**PRESSURE GAUGES**

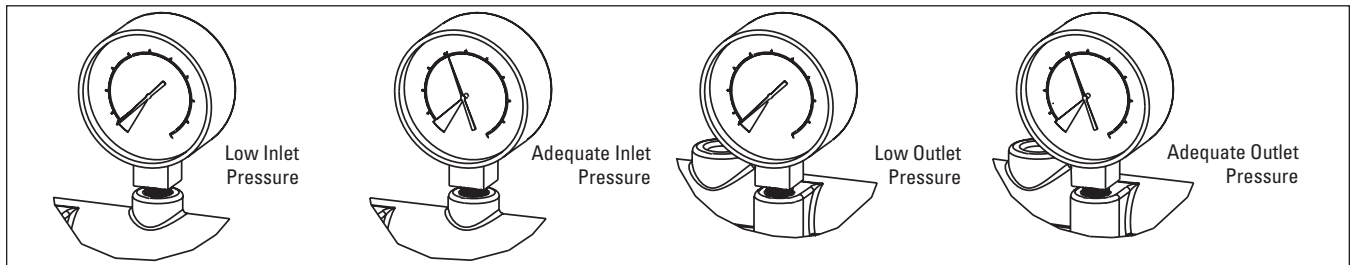

**CARTRIDGE CHANGE & FLUSHING PROCEDURES**

**Prefilter Cartridge Change**

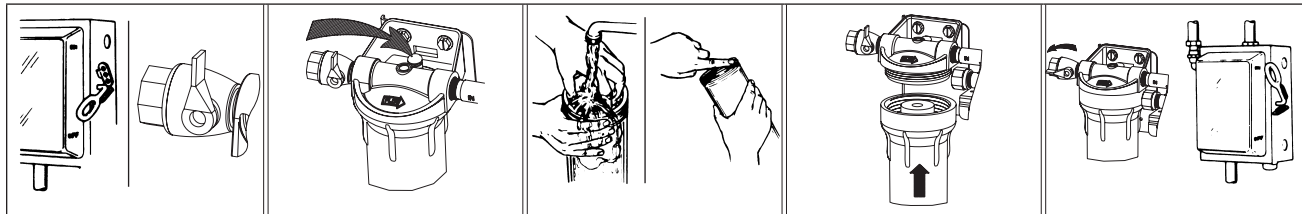

1. Shut off power to equipment. Shut off inlet water ahead of system.
2. Push red relief valve. Unscrew bowl. Remove prefilter cartridge.
3. Clean bowl with filtered water only; no special cleaners.
4. Feel head o-ring. If dry, lubricate with high quality silicone lubricant.
5. Install new prefilter cartridge in bowl. Hand tighten bowl onto head.
6. Turn on water. Turn on power to equipment.

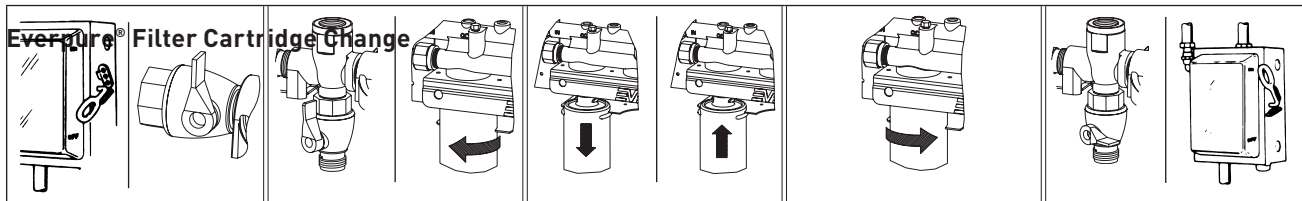

1. Shut off power to equipment. Shut off inlet water ahead of system.
2. Open flushing valve to relieve pressure.
3. Hold head firmly and push upward. Turn cartridge to left until it stops.
4. Pull cartridge downward and out of head.
5. Hold head firmly. Align cartridge lug with label. Insert new cartridge firmly into head.
6. Turn cartridge to right 90° until rotation stops.
7. Repeat steps 3 – 6 for remaining cartridges.
8. With flushing valve fully open, open inlet water at full force for 10 minutes. Close flushing valves.
9. Turn power on to equipment.

# LIMITED WARRANTY

## COMMERCIAL WATER TREATMENT EQUIPMENT

You have just purchased one of the finest water treatment units made. As an expression of confidence in this product, Pentair Filtration Solutions, LLC ("PFS") offers the following product warranty. This product is warranted against material defects in materials and workmanship to the original end-user when installed in accordance with the PFS specifications. The warranty period commences on the date of purchase and is administered as follows:

**For a period of ONE YEAR Replaceable elements (i.e., filter & water treatment cartridges)\***  
**For a period of FIVE YEARS The entire system (excluding replaceable elements)**

The unit must be used in operating conditions that conform to PFS's recommended guidelines. This warranty will not apply if the unit has been modified, repaired or altered by someone not authorized by PFS.

**If a part described above is found to have a material defect in materials or workmanship within the specified warranty period, you should notify Pentair® Everpure technical service at the phone number listed below. Any part found materially defective within the terms of this warranty will be repaired or replaced (at PFS's discretion) by your local dealer or Pentair Everpure technical service. You pay only freight from our factory and local dealer charges. Any item repaired or replaced pursuant to this warranty will be covered under the original warranty terms of the system.**

PFS is not responsible for damage caused by accident, fire, flood, freezing, Act of God, misuse, misapplication, neglect, oxidizing agents (such as chlorine, ozone, chloramines and other related components), alteration, installation or operation contrary to our printed instructions, or by the use of accessories or components which do not meet PFS's specifications. Refer to the specifications section in the Installation and Operating manual for approved application parameters.

Our product performance specifications are furnished with each water treatment unit. TO THE EXTENT PERMITTED BY LAW, EVERPURE DISCLAIMS ALL IMPLIED WARRANTIES, INCLUDING WITHOUT LIMITATION WARRANTIES OF MERCHANTABILITY AND FITNESS FOR PARTICULAR PURPOSE; TO THE EXTENT REQUIRED BY LAW, ANY SUCH IMPLIED WARRANTIES ARE LIMITED IN DURATION TO THE PERIOD SPECIFIED ABOVE FOR THE ENTIRE WATER TREATMENT UNIT.

As a manufacturer, we do not know the characteristics of your water supply or the purpose for which you are purchasing this product. The quality of water supplies may vary seasonally or over a period of time, and your water usage rate may vary as well. Water characteristics can also differ considerably if this product is moved to a new location. For these reasons, we assume no liability for the determination of the proper equipment necessary to meet your requirements, and we do not authorize others to assume such obligations for us. Further, we assume no liability and extend no warranties, express or implied, for the use of this product with a non-potable water source or a water source which does not meet the conditions for use described in the owner's guide or performance data sheet for this product.

OUR OBLIGATIONS UNDER THIS WARRANTY ARE LIMITED TO THE REPAIR OR REPLACEMENT (AT PFS'S DISCRETION) OF THE FAILED PARTS OF THE WATER TREATMENT UNIT, AND WE ASSUME NO LIABILITY WHATSOEVER FOR DIRECT, INDIRECT, INCIDENTAL, CONSEQUENTIAL, SPECIAL, GENERAL OR OTHER DAMAGES.

Some states do not allow the exclusion of implied warranties or limitations on how long an implied warranty lasts, so the above limitation may not apply to you. Similarly, some states do not allow the exclusion of incidental or consequential damages, so the above limitation or exclusion may not apply to you. This warranty gives you specific legal rights, and you may also have other rights which vary from state to state.

\*Warranty applies to material defects in materials & workmanship only.



Pentair Everpure Technical Support:  
Phone: 800.942.1153 (US Only) • 630.307.3000  
Email: [servicespecialist@pentair.com](mailto:servicespecialist@pentair.com)

### FILTRATION & PROCESSING SOLUTIONS

EVERPURE-SHURFLO WORLD HEADQUARTERS, 1040 MUIRFIELD DRIVE, HANOVER PARK, IL 60133 USA • [WWW.EVERPURE.COM](http://WWW.EVERPURE.COM)  
800.942.1153 (US ONLY) • 630.307.3000 MAIN • 630.307.3030 FAX • [CSEVERPURE@PENTAIR.COM](mailto:CSEVERPURE@PENTAIR.COM) EMAIL

EVERPURE-SHURFLO AUSTRALIA, 1-21 MONASH DRIVE, DANDENONG SOUTH, VIC 3175, AUSTRALIA  
011.1300.576.190 TEL • 011.61.39.562.7237 FAX • [AU.EVERPURE@PENTAIR.COM](mailto:AU.EVERPURE@PENTAIR.COM) EMAIL

EVERPURE-SHURFLO CHINA, 21F CLOUD 9 PLAZA, NO 1118, SHANGHAI, 200052, CHINA  
86.21.3211.4588 TEL • 86.21.3211.4580 FAX • [CHINA.WATER@PENTAIR.COM](mailto:CHINA.WATER@PENTAIR.COM) EMAIL

EVERPURE-SHURFLO INDIA, GREEN BOULEVARD, B-9/A, 7TH FLOOR - TOWER B SECTOR 62, NOIDA - 201301  
91.120.419.9444 TEL • 91.120.419.9400 FAX • [INDIACUSTOMER@PENTAIR.COM](mailto:INDIACUSTOMER@PENTAIR.COM) EMAIL

EVERPURE-SHURFLO EUROPE, PENTAIR WATER BELGIUM BVBA, INDUSTRIEPARK WOLFSTEE, TOEKOMSTLAAN, 30 B-2200 HERENTALS, BELGIUM  
+32.(0).14.283.500 TEL • +32.(0).14.283.505 FAX • [SALES@EVERPURE-EUROPE.COM](mailto:SALES@EVERPURE-EUROPE.COM) EMAIL

EVERPURE-SHURFLO JAPAN INC., HASHIMOTO MN BLDG. 7F, 3-25-1 HASHIMOTO, MIDORI-KU, SAGAMIHARA-SHI KANAGAWA 252-0143, JAPAN  
81.(0)42.775.3011 TEL • 81.(0)42.775.3015 FAX • [INFO@EVERPURE.CO.JP](mailto:INFO@EVERPURE.CO.JP) EMAIL

EVERPURE-SHURFLO SOUTHEAST ASIA, SOUTHEAST ASIA, 390 HAVELOCK ROAD, #04-01 KING'S CENTRE, SINGAPORE 169662  
65.6768.5800 TEL • 65.6737.5149 FAX • [CSEVERPURE@PENTAIR.COM](mailto:CSEVERPURE@PENTAIR.COM) EMAIL

All Pentair trademarks and logos are owned by Pentair, Inc. or its affiliates. All other registered and unregistered trademarks and logos are the property of their respective owners. Because we are continuously improving our products and services, Pentair reserves the right to change specifications without prior notice. Pentair is an equal opportunity employer.