



COUNTERTOP RO INSTALLATION MANUAL

INTRODUCTION

We are delighted that you have chosen an Express Water Countertop RO System!

As a trusted brand, we always strive to provide high-quality products and excellent customer service.

To ensure that you get the most out of your purchase, please take the time to read this installation and operation manual carefully.

This manual contains important information on how to install, use, and maintain your product correctly to maximize its performance. Please also make sure to inspect the package for any missing components or shipping damages.

Thank you again for choosing our water purification products. We are confident that you will enjoy the benefits of clean and safe drinking water for years to come.

Should you encounter any issues while using our product, our dedicated team of professionals is here to assist you. If you find any issues or have questions please contact us at **1-800-992-8876** or visit our website at **www.expresswater.com**.

TABLE OF CONTENTS

Introduction	P. 3
Table Of Contents	P. 3
Conditions	P. 4
Technical Specifications	P. 5

INSTALLATION

System Components	P. 5
Product Details	P. 6
Before Use	P. 7
System Use	P. 8
System Maintenance	P. 9
Daily Maintenance	P. 9
Filter Change Instructions	P. 10-11
Troubleshooting	P. 12-13
Replacement Filters / Replacements Table	P. 14
Warranty	P. 15



CONDITIONS READ THIS FIRST!

Please pay attention to the following installation and safety recommendations and read the manual before installing this system.

- Do not use power cords or plugs that are damaged or have loose sockets.
- If the power cord is damaged, it must be repaired by a designated professional after-sales technician or replaced by qualified personnel to avoid danger.
- Do not carry the device by pulling the power cord.
- Do not touch the power plug with wet hands.
- Do not forcibly bend the power cord or place it under heavy objects to avoid damage or deformation.
- Do not share a socket with multiple other electrical appliances.
- Do not install this product near heating equipment.
- Do not put flammable, explosive, volatile, or strong magnetic substances close to the system.
- Do not immerse the product in water, spray water directly to clean the machine, or place the system in water.
- Do not apply great pressure or impact to this product.
- Do not place this product on a sloping floor or table.
- Water source water quality, inlet water temperature, time of system use, usage habits can all affect the recycle raw water rate.
- The product is intended for indoor use only.
- When the water level of the original water tank is below the MIN water change line, replace the water source and do not add water repeatedly to avoid poor quality of raw water that affects the quality of effluent water.
- Do not put your hands on the water outlet during operation to avoid burns.
- Only maintenance technicians are allowed to disassemble and repair this product to avoid causing fire or electric shock.
- Please plug the product into a US-style socket.
- This product needs to be repaired by company professionals. Please do not disassemble the parts of the product yourself.



TECHNICAL SPECIFICATIONS

Product name	Express Water Countertop RO System
Product SKU	ROC001
Clean water flow	0.034G/min. (0.13L/min.)
Rated voltage	110V 60Hz
Rated power	1565W
Applicable water temperature	41-100 °F (5-38 °C)
Ambient temperature	39-104 °F (4-40 °C)
Inlet pressure	0~0.3MPa
Work pressure	0.4~0.6MPa
Rated total net water volume	1500L
Electric shock protection type	Type 1
Applicable water source	Municipal tap water
Water quality	Conforms to the requirements of "Drinking Water Quality Processor Hygienic Safety and Functional Evaluation Specification - Reverse Osmosis Treatment Device" (2001)
Product size	18.6"×8.3"×16" (472×212×407mm)

SYSTEM COMPONENTS

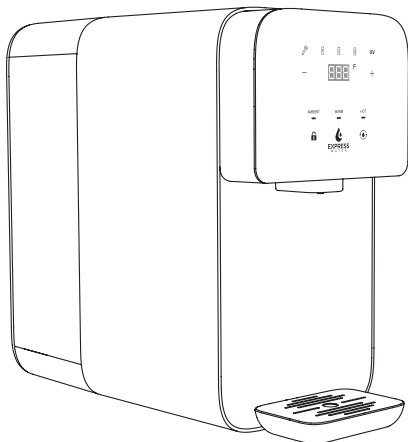

Countertop RO System

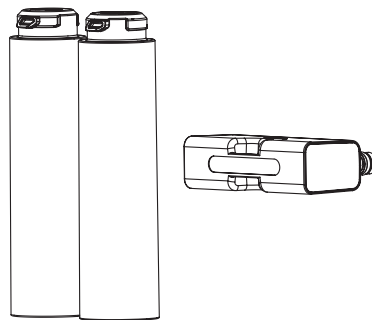

Filter Set



Water Collection Tray

PRODUCT DETAILS

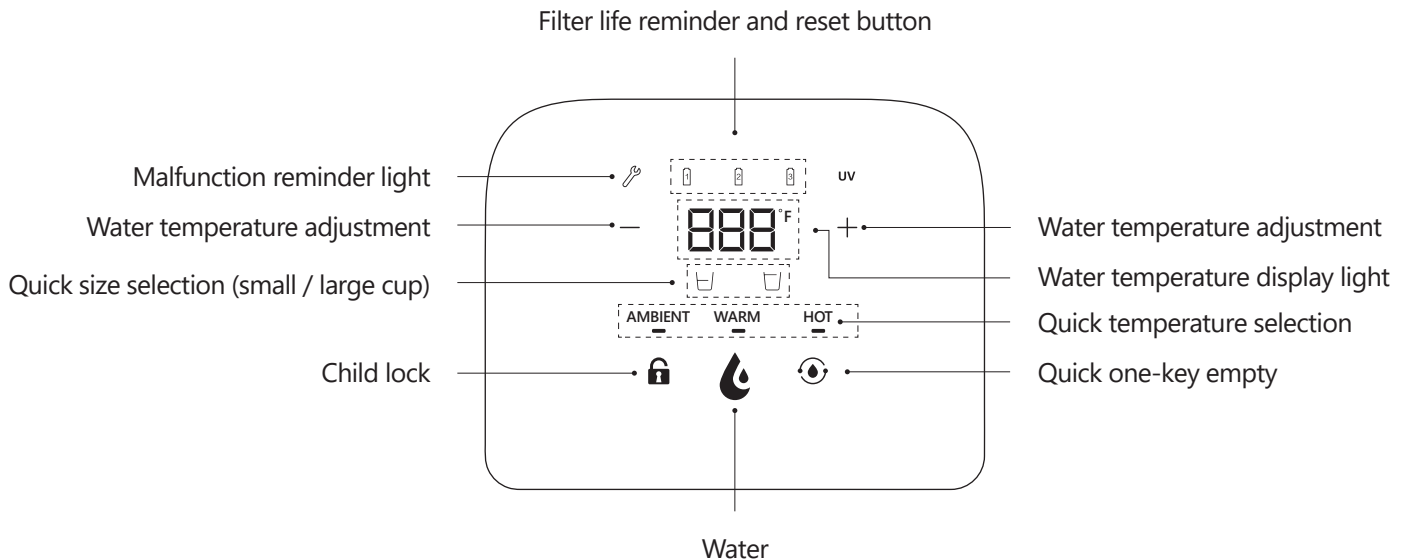
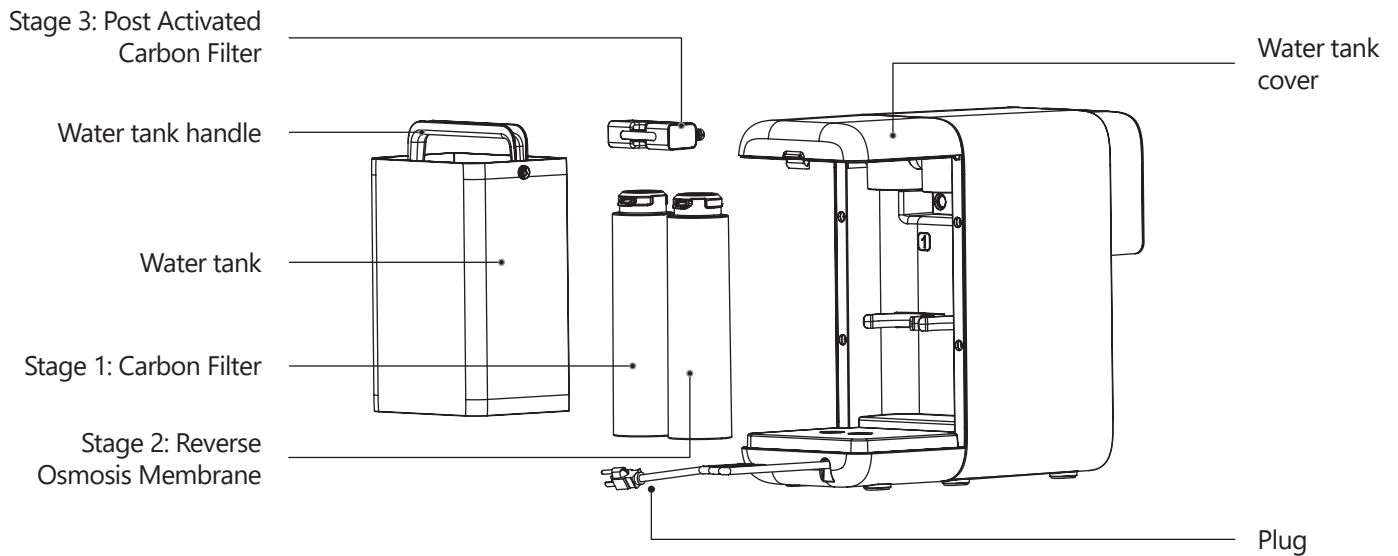
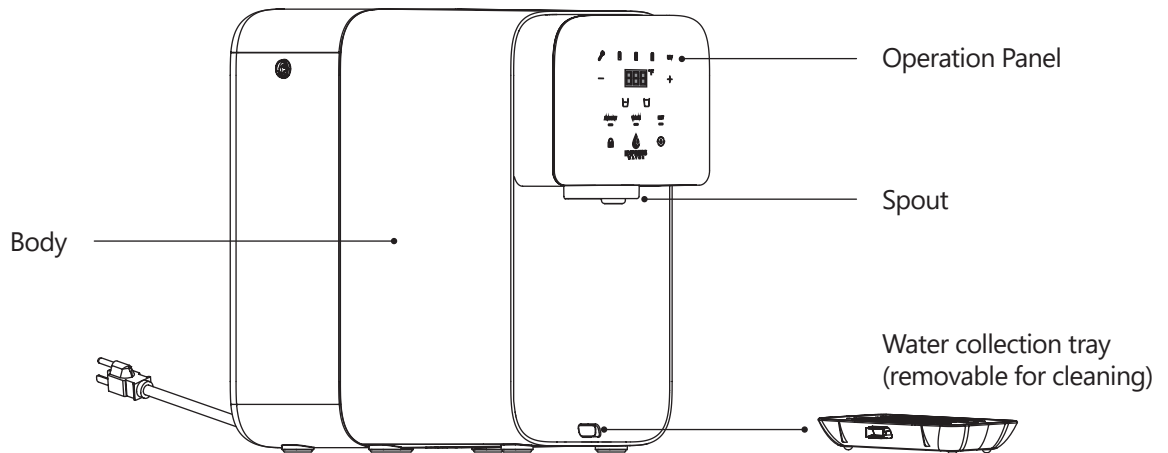

BEFORE USE

1. Placement

Open the packaging box and remove the entire machine, placing it on a table. Take the water collection box from the package and insert it into the card slot of the machine.

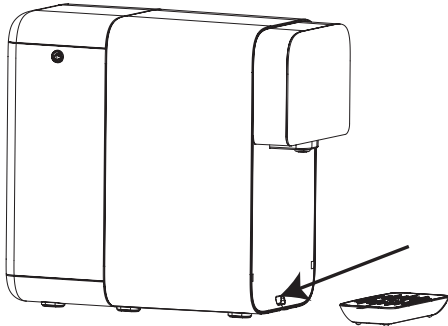

2a. Filling the water tank

Open the upper cover of the water tank and lift out the tank. After rinsing the tank, fill it with an appropriate amount of water, ensuring that the water level remains below the maximum scale but above the minimum line.

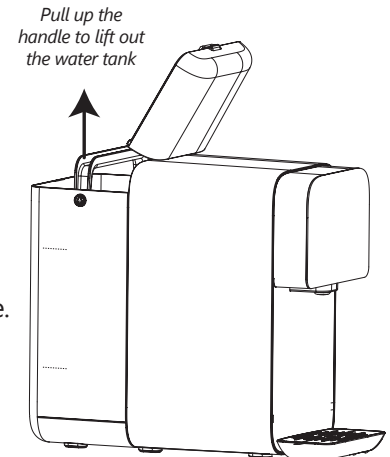

2b. Note: When filling the water tank, ensure that both the raw water area and the waste water area are filled up to the highest water level (as shown in the picture).

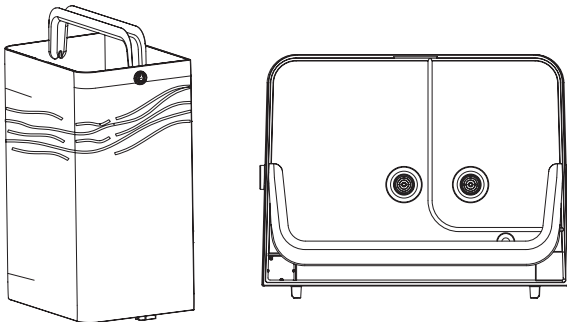

3. Powering on

Place the water tank into the machine, close the top cover, and plug in the power.

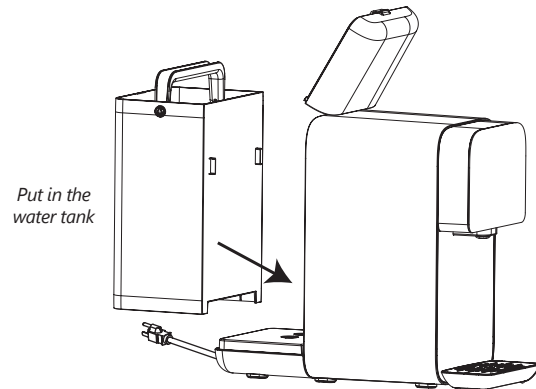

4. Flushing the filter element

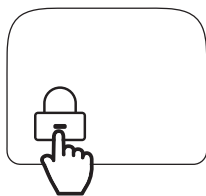

Step 1: Unlock
Press and hold the child lock button for one second to unlock the full screen.



Step 2: Water production mode, the screen displays C1.
The machine will start producing water for the first time. Please be patient and wait for approximately 13 minutes.



Step 3: One-key emptying
Press the button to empty the water in the pure water tank inside the machine.

⚠ Note: For the first use, it is recommended to repeat steps 1, 2, and 3 to flush the entire machine and the filter element. We suggest flushing with three buckets of water. This process may take some time, so please be patient. The first flush is to clean the filter element and pipeline, and the water may appear gray-black or bubble-like, which is normal. Continue to flush until the water runs clear.

SYSTEM USE

Water Dispensing Procedure:

To fill the water tank, repeat steps 2 and 3 in the "Before Use" section and plug in the machine.

If the device is in sleep mode, simply touch any key on the screen to wake it up.



To unlock, press and hold the child lock button for 1 second.

To lock it, lightly touch the button.

UV Function:

1. After powering on, the UV sterilization indicator will light up, and the sterilization process will continue for 1 hour.
2. After each water production cycle, sterilization for 10 minutes will be carried out.
3. If the device is in standby mode for more than 50 minutes, the sterilization process will be performed for 10 minutes, and this cycle will repeat in standby mode.

Temperature Selection - you can choose between two temperature modes:

Shortcut Mode	Custom Mode
<p>AMBIENT WARM HOT</p> <p> </p> <p>Room Temperature 113°F (45°C) 203°F (95°C)</p>	<p>Click to add or subtract 1 degree; long press to speed up adjustment.</p> <p>— °F </p>

Water Outlet Mode Selection:

Shortcut Mode	Custom Mode
<p>Press cup to select, then press Water Button. When at preset limit, water stops.</p> <p> → </p> <p>Small Cup Large Cup</p> <p>4oz (120ml) 8.5oz (250ml)</p>	<p>Dispense water Press again to stop</p> <p> → </p>

First Cup of Hot Water:

When the screen displays C3, the first cup of hot water will be at room temperature every time the power is turned on. So, when you want to drink hot tea, don't worry. Just start the procedure again.

Example - water for hot tea:

<p>AMBIENT WARM HOT</p> <p> </p> <p>Room Temperature 113°F (45°C) 203°F (95°C)</p>	<p> → </p> <p>Dispense water</p>	<p>Q: Why isn't the water hot? A: No need to panic! The system is designed this way. Simply run the procedure again to obtain hot water.</p>
---	----------------------------------	--



SYSTEM MAINTENANCE

If you see the screen displaying **C1**, the machine is currently producing water. You may not be able to dispense water at this moment, so please be patient. After waiting for approximately two minutes, you can try dispensing water again.

When the screen displays **C2**, it means that the water tank is running low (when the water level falls below the water level line). You can resolve this issue by opening the top cover of the water tank, lifting out the water tank, pouring out the remaining water, and filling it up with new tap water. After you close the machine and its top cover, the machine will return to normal use (note: if you recycle the old water this can cause the membrane to foul over time).

If the screen displays **E1**, it indicates a system malfunction, and the fault light will flash. To fix this, you need to put the water tank back into the machine and cover it with the water tank cover. This will eliminate the alarm and allow the machine to continue functioning normally.

DAILY MAINTENANCE

1. Please wipe the machine with a soft cloth.
2. For stubborn stains or dust, use a soft cloth with warm water.
3. Do not use volatile liquids like alcohol, gasoline, paint thinner, polishing powder, or other materials, as they may damage the machine's surface.
4. Do not wash the exterior or interior of the product with water. Rinsing the interior with water may cause water accumulation, leading to odors and bacterial growth.

If you don't plan to use the machine for an extended period:

1. Empty the water tank.
2. Press and hold the  button for 2 seconds to drain the water until the icon disappears.
3. Disconnect the power supply.

When using the machine again:

1. Clean the water tank, fill it with tap water, and plug in the power supply. Wait for it to produce water.
2. Press and hold the  button for 2 seconds to drain the water until the icon disappears. It's recommended to rinse a bucket of water.
3. Follow the "System Use" operation method for normal use.

FILTER CHANGE INSTRUCTIONS

When viewing the interface, an alert will flash indicating that the corresponding filter element has reached the end of its life.



Please replace it according to the flashing light.

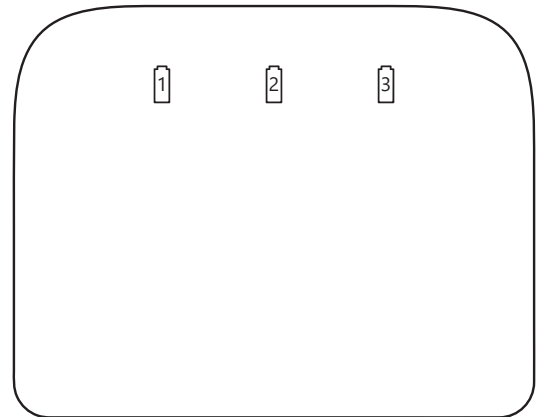

The recommended filter replacement intervals are as follows:

Filter Number	Filter Name	Recommended replacement cycle
1	Carbon Filter	Every 3-6 months*
2	Reverse Osmosis Membrane	Every 24 months*
3	Post Activated Carbon Filter	Every 3-6 months*

Before replacing the filters:

1. Unplug the machine power plug.
2. Open the tank lid
3. Lift out the water tank, placing it next to the machine.

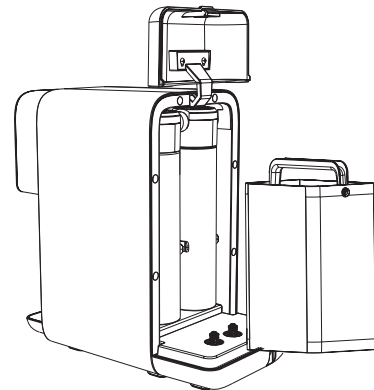

To replace the first and second filter elements:

1. Lift the filter element by hand and tilt it to an angle of about 45 degrees for easy rotation and removal.
2. Rotate the filter element counterclockwise, as shown in the picture, to remove it.
3. Turn the new filter element clockwise until you hear a "click" sound, indicating that it is installed correctly. Press it down into the machine.

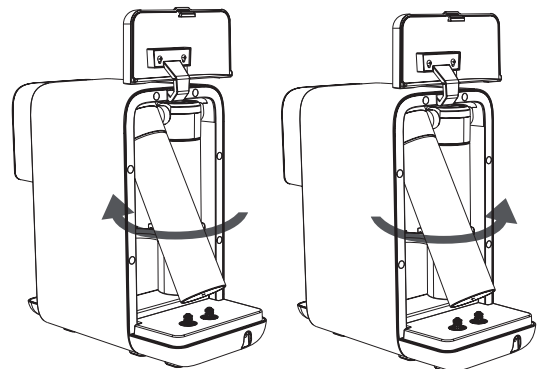

*Depending On Incoming Water Quality



To replace the third filter element:

1. Remove the first and second filter elements.
2. Pull out the third filter element as shown in the picture.
3. Firmly insert the new filter element.
4. Put the first and second filter elements back in place.

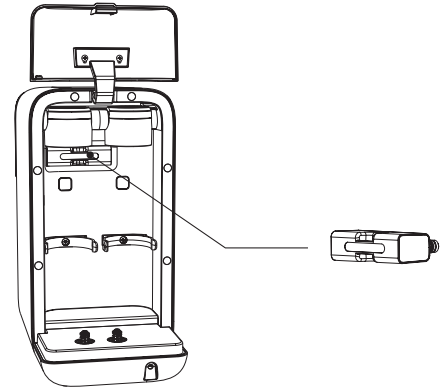

Reset and replace the water tank, fixing it tightly into place, and close the water tank cap.

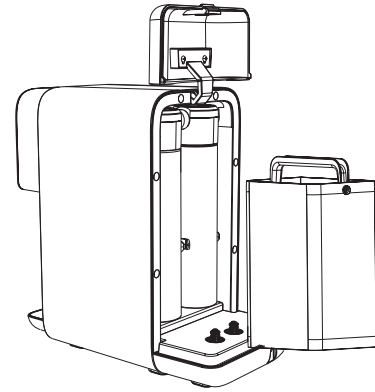

To reset the filter element:

1. Unlock the child lock.
2. The indicator light of the filter element that needs to be reset will flash.
3. Press and hold the indicator light of the corresponding filter element for 2 seconds to reset it.
4. The buzzer will sound once, and the filter element icon will turn on, indicating that the filter element has been reset successfully.
5. The filter element icon will turn off.

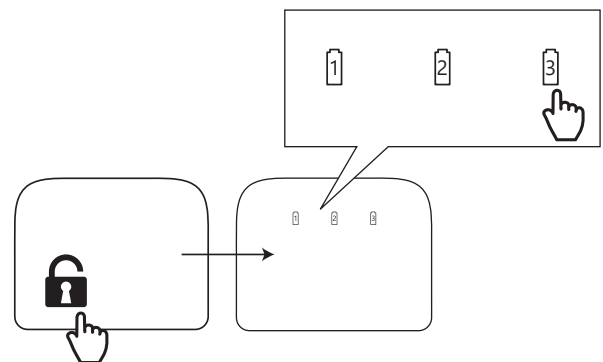

Before using the machine, repeat the following steps to flush the filter elements:

When any of the filter indicator lights are on, it is recommended to flush three buckets of water using the dedicated button.

These steps will ensure that the new filter element is properly flushed and ready for use.

TROUBLESHOOTING

PROBLEM	CAUSE
Unable to produce / process water	<p>Check whether the plug and socket are properly connected.</p> <p>Make sure that the filter element is installed correctly.</p> <p>Check whether the temperature of the water tank is lower than 0°C.</p> <p>Check whether the fault light is flashing.</p>
Low flow of pure water	<p>Check whether the filter elements at all levels are clogged.</p> <p>Check whether the filter element replacement life indicator is flashing, indicating that the replacement cycle has been reached.</p> <p>Make sure that the filter element is installed correctly and in place.</p>
No hot water	<p>Check whether the water outlet indicator light is flashing and wait to continue water production.</p> <p>Make sure that the machine is unlocked.</p> <p>Check whether the machine failure maintenance indicator light is on.</p>
E1 error displayed on the operation interface	<p>If the raw water tank cover is not in place, the operation interface displays E1, and the fault light flashes red.</p> <p>Solution: Place the raw water tank and tank cover correctly and observe the working condition of the machine. If the machine is still in a faulty state, please contact the customer service center for assistance.</p>
E2 error displayed on the operation interface	<p>If the machine produces water continuously for 30 minutes, it is considered "abnormal water production," and the operation interface will display E2, and the fault light will flash red.</p> <p>Solution: Reconnect the power supply to reset the fault state, observe the working condition of the machine. If the machine is still in a faulty state, please contact the customer service center for assistance.</p>
E3 error displayed on the operation interface	<p>When the heater of the machine is dry without water (the temperature exceeds the set value), the operation interface will display E3, and the fault light will flash red.</p> <p>Solution: Wait for about 5 minutes, or dispense ambient water to lower temperature. If the machine is still in a faulty state, please contact Express Water support for assistance.</p>
E4 error displayed on the operation interface	<p>When both the high and low liquid levels of the pure water tank of the machine are valid at the same time, the digital tube in the display interface will display E4, and the fault light will flash red.</p> <p>Solution: Replug the power supply. If there is no change, the water level float detector of the pure water tank may have failed, and you need to contact Express Water support for assistance.</p>



PROBLEM	CAUSE
<p>E5 error displayed on the operation interface</p>	<p>When the machine cannot detect the inlet water temperature, the operation interface will display E5, and the fault light will flash red. Solution: If the inlet water temperature probe fails or is not installed properly, you need to contact Express Water support for assistance.</p>
<p>E6 error displayed on the operation interface</p>	<p>When the machine cannot detect the outlet water temperature, the operation interface will display E6, and the fault light will flash red. Solution: If the outlet water temperature probe fails or is not installed properly, you need to contact Express Water support for assistance.</p>
<p>E7 error displayed on the operation interface</p>	<p>When the display board of the machine is unable to communicate with the power board, the operation interface displays E7 and the fault light flashes red. Solution: If the connection between the display board and power board is poor, or if either board is malfunctioning, please contact Express Water support for assistance.</p>
<p>C1 displayed on the operation interface</p>	<p>C1 Alert: The machine is currently producing pure water, and it may take up to 13 minutes before the water can be dispensed. Please be patient and wait for the process to complete.</p>
<p>C2 displayed on the operation interface</p>	<p>C2 Alert: The water tank is low on water, and the water level has fallen below the minimum level required for operation. To fix this, open the top cover of the raw water tank, lift it out, pour out any remaining water, refill the tank with fresh tap water, close the top cover, and resume normal use of the machine.</p>
<p>C3 displayed on the operation interface</p>	<p>C3 Alert: When the machine is powered on, the first cup of hot water dispensed will be at normal temperature. This is a normal occurrence and is due to the system's internal settings.</p>
<p>C4 displayed on the operation interface</p>	<p>C4 Alert: This alert indicates that the machine is currently emptying water using the one-key function.</p>

REPLACEMENT FILTER CHART

Replacement Filters: Express Water offers replacement filters for your Countertop RO system.
For purchasing information, please visit us at www.expresswater.com.

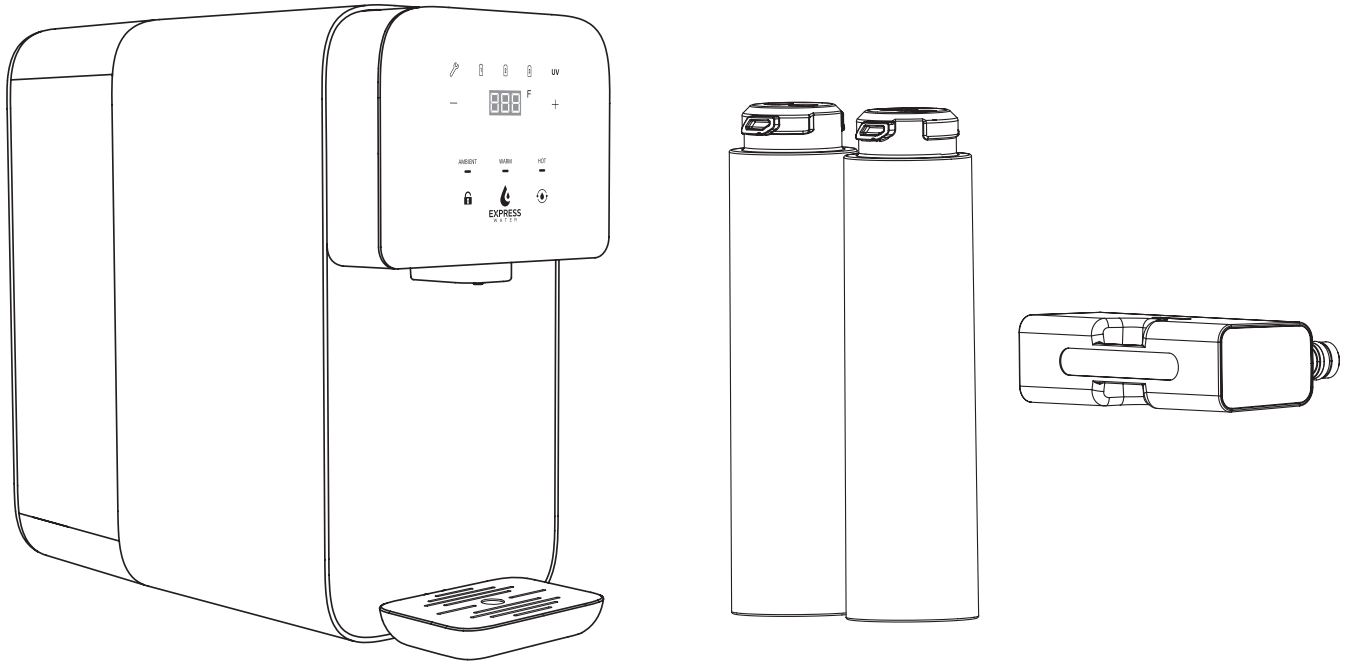

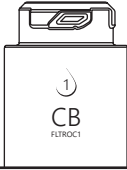
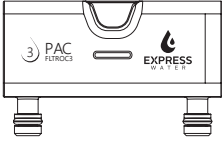
INSTALLATION DATE:			
Filters	Carbon Filter	PAC Filter	RO Membrane
			
Model	Sold as filter set: FLTSETROC1		FLTROC2
	FLTROC1	FLTROC3	
Service Life*	3-6 Months*	3-6 Months*	24 Months*
Change 1			
Change 2			
Change 3			
Change 4			

*Depending On Incoming Water Quality





EXPRESS
W A T E R

1 YEAR LIMITED WARRANTY

As manufacturer, we do not know the characteristics of your water supply or the purpose for which you are purchasing a drinking water system. Please understand that the quality of water supplies may vary seasonally or over a period of time, and that your water usage rate may vary as well. Water characteristics can also change considerably if your drinking water system is moved to a new location. For these reasons, we assume no liability for the determination of the proper equipment necessary to meet your requirements, and we do not authorize others to assume such obligations for us.

Further, we assume no liability and extend no warranties, express or implied, for the use of this product on a non-potable water source. OUR OBLIGATIONS UNDER THIS WARRANTY ARE LIMITED TO THE REPLACEMENT OF THE FAILED PARTS OF THE DRINKING WATER SYSTEM, AND WE ASSUME NO LIABILITY WHATSOEVER FOR DIRECT, INCIDENTAL, CONSEQUENTIAL, SPECIAL, GENERAL, OR OTHER DAMAGES, WHETHER FROM CORROSION OR OTHER CAUSES.

We Cover

This warranty covers any defects in the parts or manufacturing of your Express Water Reverse Osmosis Water System. Where applicable, we will give you new replacement parts in exchange for any defective parts.

What to Do

Give us a call at 1-800-992-8876 or send an email to support@expresswater.com and describe the problem to our support. Be sure to have a copy of your purchase confirmation email or receipt. Our support will verify that the product and problem are under warranty and help you arrange to send your defective part back to Express Water with your receipt and contact information (name, address, phone number, email address). Support will help arrange sending of the defective part, the delivery of your replacement part, as well as guiding you through the installation.

Time Covered

This warranty is effective for 1 full year from the date of original purchase.

Not Covered

This warranty does not cover labor for removal or installation, accumulation of dirt or grime (you are responsible for your own cleaning), systems with the serial number removed or altered, damage from improper storage (high or low temperature, sun damage, etc), damage from a system not installed as instructions directed, anyone other than original purchaser, damage from system abuse or unintended operation of system, accident, fire, flood, freezing, or any acts of God, improper water source, modification, negligence, commercial use of the system, Filters, RO Membrane, incidental damages from system failure, systems used with parts not provided by Express Water (including tanks, filters, faucets, pumps, diverter valves), or cosmetic damages.

Your State

Some states have further regulation on damages and warranty coverage. You may have other rights depending on your state.

For warranty questions, service, or help give us a call: **Monday - Friday 10 am to 5 pm PST: 1-800-992-8876**

support@expresswater.com • www.expresswater.com

Express Water Inc. **13030 Raymer St, North Hollywood, CA 91605**



EXPRESS
W A T E R

For warranty questions, service, or help give us a call:

Monday - Friday 10 am to 5 pm PST: 1-800-992-8876

support@expresswater.com • www.expresswater.com

EXPRESS WATER INC. 13030 Raymer St, North Hollywood, CA 91605