



POP UP SOLAR STREET LIGHT Instruction Manual



moma
solar

Head Office

1/3-5 McElligott Court Canning
Vale, WA, 6155

08 6141 3204

info@momasolar.com.au

momasolar.com.au

STOP AND THINK





moma
solar

MOMA Solar Pop Up Light Instruction Manual

Safety Information



PLEASE READ BEFORE INSTALLATION

Please read all instructions carefully and note these must be used in conjunction with your own site safety rules and applicable regulations.

Always obey site safety rules and report any defects immediately to your Supervisor or Management. If in doubt always consult your Supervisor or Manager. This Manual contains Warnings and Cautions which must be followed to prevent any personnel injuries, death or equipment damage. The following notices will be observed when setting up the Solar Pop-Up Light.



Warnings

-  **WARNING** INDICATES A HAZARDOUS SITUATION WHICH IF NOT AVOIDED COULD RESULT IN SERIOUS INJURY OR DEATH
-  **CAUTION** INDICATES A HAZARDOUS SITUATION WHICH IF NOT AVOIDED COULD RESULT IN MINOR OR MODERATE INJURY
-  **CAUTION** INDICATES A HAZARDOUS SITUATION WHICH IF NOT AVOIDED COULD RESULT IN PROPERTY OR EQUIPMENT DAMAGE

It is important that before using or setting up the solar pop-up light, be sure to read and understand all of the instructions, and that all of the local site safety rules and regulations are followed.

The equipment is designed for specific applications and must be used as per instructions.

Do not modify the equipment in any way. Modification of equipment could lead to injury of personnel and will void warranty of all modified components.

Safety Instructions

The area where the solar pop-up lights will be set up must be dry and free of debris.

Ensure the area where solar pop-up lights are to be set up is firm, free of subsidence and level.

Position the solar pop-up light on firm level ground. Never set up the solar pop-up light on Unstable or tilted ground .

Always lower the solar pop-up light in very high winds or electrical storms (rated in accordance with AS1170 part 2).

Keep the area surrounding the solar pop-up light clear whenever lowering or raising light

Do not move full unit when it contains water.

Use cation when lifting base by forklift. Ensure area is clear of personnel.

Only use mild soap and water to clean the Solar Panels.

ALWAYS ENSURE THE BASE IS FULL WHEN IN OPERATION

Manual Handling Safety

Carry out risk assessment of the task before carrying out any work.



moma
solar

Head Office

1/3-5 McElligott Court Canning
Vale, WA, 6155

08 6141 3204

info@momasolar.com.au

momasolar.com.au

STOP AND THINK





moma
solar

MOMA Solar Pop Up Light Instruction Manual

1. Supplied Parts

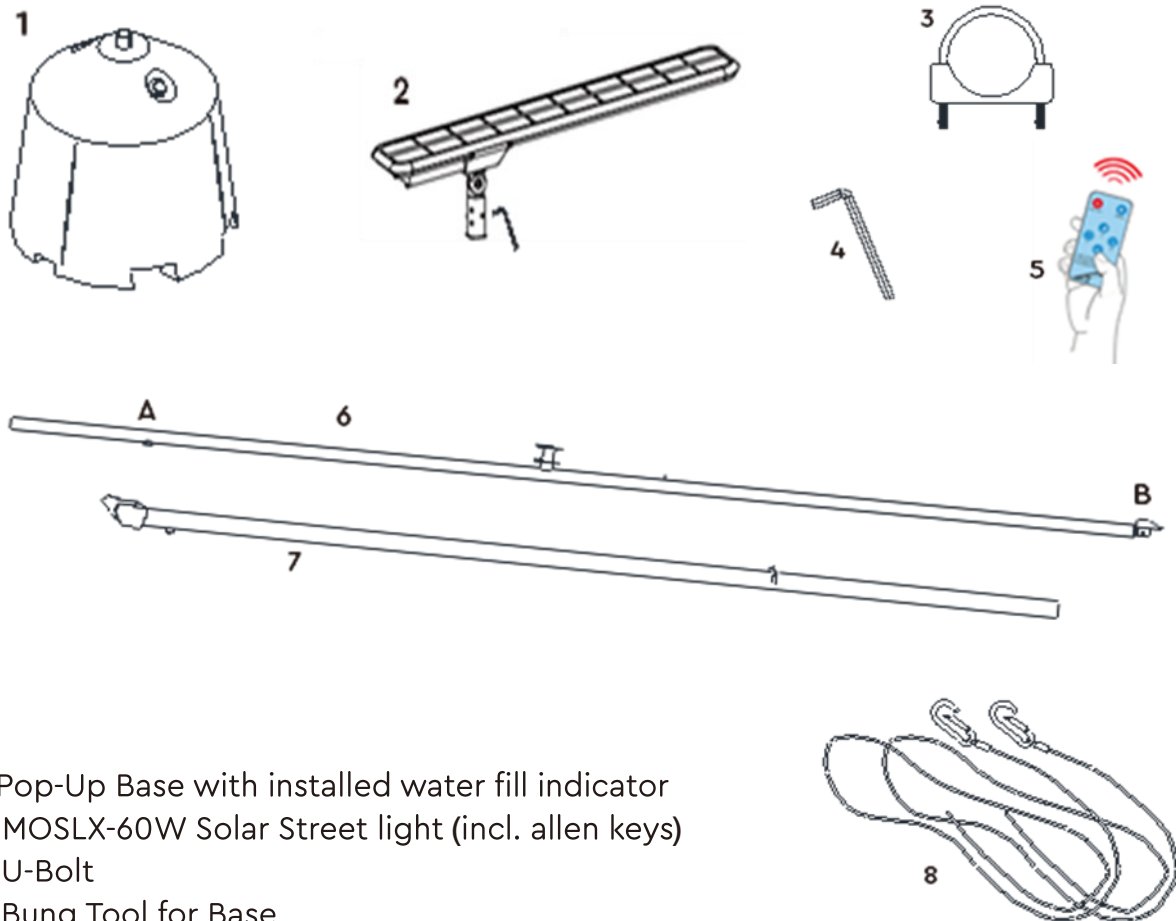

- 1 - Pop-Up Base with installed water fill indicator
- 2 - MOSLX-60W Solar Street light (incl. allen keys)
- 3 - U-Bolt
- 4 - Bung Tool for Base
- 5 - Remote Control
- 6 - Swivelpole™ – long pole (Top & Bottom Labelled A & B)
- 7 - Swivelpole™ – short pole
- 8 - 2 x 6.5m ropes with Carabiners

Please ensure all parts are present. If any parts are missing, please contact MOMA Solar



moma
solar

Head Office

1/3-5 McElligott Court Canning
Vale, WA, 6155

08 6141 3204

info@momasolar.com.au

momasolar.com.au

STOP AND THINK





2. Assembling the Pop Up

Step 1 – Layout parts and check all are present. Ensure base is in its final destination on level ground. Ensure this area is free of powerlines, existing street lighting or LED light towers, trees or tall buildings that could affect the functionality of the MOSLX fitting. Lay base on side and chock unit securely at front and on two sides ensuring top of base is propped up to be horizontally level.

Step 2 – Lay out pole parts 6 & 7 to create the G5 pole as per images below. Facing A end of pole 6 towards top of base.

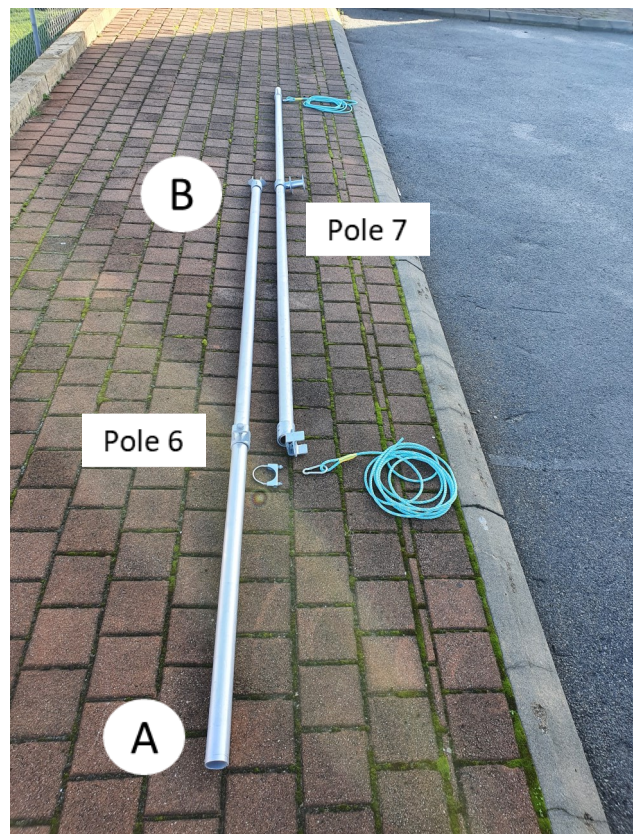
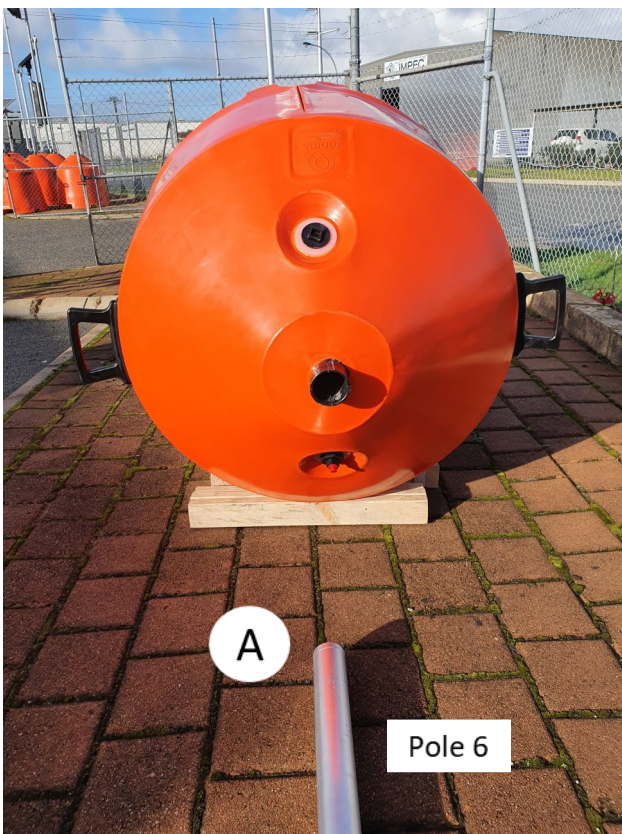



moma
solar

MOMA Solar Pop Up Light Instruction Manual

Step 3 – Undo bolt located in the centre of pole 6. If this bolt is not present please contact MOMA Solar. **This bolt cannot be substituted.**  **WARNING**

Put this bolt aside as it will be used to secure the two separate poles together.



Step 4 – Place poles side by side in the positions shown below. Slide the reel on pole 6 into the top slot of pole 7. Secure both poles together at bottom of pole 7 with bolt removed in Step 3, ensure bolt is only finger tight as it will be removed later to mount the light.



moma
solar

Head Office

1/3-5 McElligott Court Canning
Vale, WA, 6155

08 6141 3204

info@momasolar.com.au

momasolar.com.au

STOP AND THINK





moma
solar

MOMA Solar Pop Up Light Instruction Manual

Step 5 – Attach a rope & carabiner to each pole as shown below.



Step 6 – To insert pole 6 into the base, one person should stand at the top of pole 7 and one in the middle, both can then lift and slide the A end of pole 6 into the top of the base. The person at the top of the pole 7 can then carefully walk in lifting the pole hand over hand until the base is in an upright position. **⚠ CAUTION** Please ensure pole is inserted as far as possible before attempting to lift pole up.



moma
solar

Head Office

1/3-5 McElligott Court Canning
Vale, WA, 6155

08 6141 3204

info@momasolar.com.au

momasolar.com.au

STOP AND THINK





moma
solar

MOMA Solar Pop Up Light Instruction Manual

Step 7 – Install U-bolt onto base with threads pointed directly opposite to pole securing bolt and tighten.



Step 8 – Using Bung Tool check bottom bung is tightened to prevent leaks, remove top bung, insert hose and fill with water.

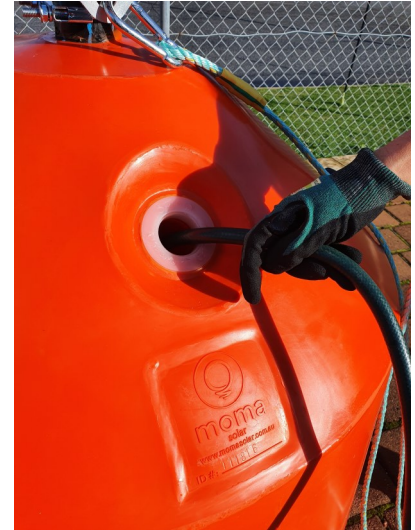
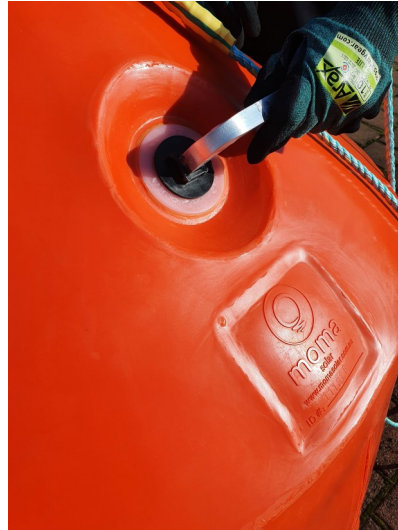

Ensure base is filled at all times during use.

Failure to ensure base is filled could lead to injury of personnel or damage of equipment



moma
solar

Head Office

1/3-5 McElligott Court Canning
Vale, WA, 6155

08 6141 3204

info@momasolar.com.au

momasolar.com.au

STOP AND THINK





moma
solar

MOMA Solar Pop Up Light Instruction Manual

3. Setting up the MOSLX fitting

Step 1 – Your MOSLX Unit will come with a set of Allen keys, blue remote, screws and bolts to suit and the adjustable spigot. Please see below images.

Please ensure all items are present. If any items are missing, please contact MOMA Solar



Step 2 – Install base of adjustable spigot to the light fitting using supplied screws, Spring washers and Nylon washers and Allen key #1.



moma
solar

Head Office

1/3-5 McElligott Court Canning
Vale, WA, 6155

08 6141 3204

info@momasolar.com.au

momasolar.com.au

STOP AND THINK





moma
solar

MOMA Solar Pop Up Light Instruction Manual

Step 3 – Using Allen key #3 and largest supplied bolt, ensure spigot on light head is angled no more than 15° and tightened. Then ensure all four bolts have been loosely placed into the spigot using Allen key #2.

If any of these four bolts are missing please contact MOMA Solar for replacement parts.

WARNING

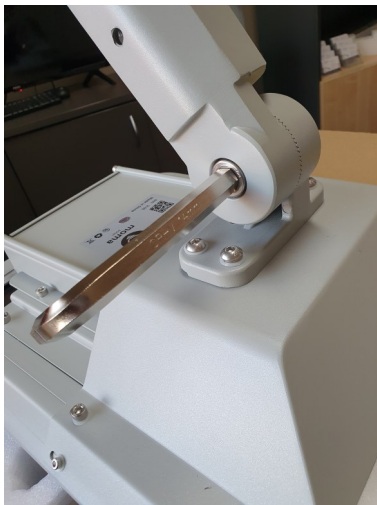

The Adjustable bracket will need to be angled no more than 15°. Failure to do so could affect operation of unit. In order to do so, simply place the adjustable bracket at the 90° angle on the mounting bracket. Each notch is equal to 5°. By angling the spigot down towards the back of the unit 3 notches, a 15° angle will be accurately achieved.



moma
solar

Head Office

1/3-5 McElligott Court Canning
Vale, WA, 6155

08 6141 3204

info@momasolar.com.au

momasolar.com.au

STOP AND THINK





moma
solar

MOMA Solar Pop Up Light Instruction Manual

Step 4 – Ensure light fitting is turned on using button located at the back of the of the light fitting. When the power button is **pressed in the unit is off**, when the button is **flush the unit is on**.



Step 5 – Press the mode button located next to the large round microwave sensor and cycle through all available modes before choosing your preferred mode. The LEDs should turn on briefly. When choosing your mode the indicator light in the microwave sensor will show briefly before returning to either Blinking Red (Not Charging) or Blinking Green (Charging).

Once mode has been chosen light is ready to be mounted.



Red Light



Orange Light



Green Light



Flashing Red Light

RED LIGHT

Microwave Control – 15 Hrs of sensor at 80% Brightness when people detected and 40% Brightness when no movement.

ORANGE LIGHT

Timing Control – First 5 Hrs at 80% Brightness, next 10 Hrs at 40% Brightness.

GREEN LIGHT

Timing & Microwave control – First 5 Hrs at 100% Brightness, next 10 Hrs of sensor at 30% Brightness when people detected and 10% Brightness when no movement.

FLASHING RED

Flashing Red - 15 Hrs at 70% Brightness

***Please see Section 5 for additional information regarding the MOSLX fitting and Troubleshooting Guide.**



moma
solar

Head Office

1/3-5 McElligott Court Canning
Vale, WA, 6155

08 6141 3204

info@momasolar.com.au

momasolar.com.au

STOP AND THINK





4. Mounting MOSLX fitting to the Pop up unit

Step 1 – Ensure the bottom rope is being held securely to **avoid the pole possibly swinging down when bolt is undone**.  CAUTION

Using a socket wrench undo the bolt at the base of the pole. Use the second rope attached to the top of the pole to rotate the pole down. **Tie the pole off securely** using a Clove hitch knot.  CAUTION





moma
solar

MOMA Solar Pop Up Light Instruction Manual

Step 2 – Have one person lift the light fitting while the other guides the pole into the spigot. Lift the light fitting until pole is inserted fully and cannot go further. Tighten the four bolts on the side using the Allen key and **ensure fitting is tightly fixed before letting go of the fitting.**

CAUTION



Step 3 – Undo knot and unclip the rope & carabiner from the pole top.



moma
solar

Head Office

1/3-5 McElligott Court Canning
Vale, WA, 6155

08 6141 3204

info@momasolar.com.au

momasolar.com.au

STOP AND THINK





moma
solar

MOMA Solar Pop Up Light Instruction Manual

Step 4 – Using second rope , pull downwards until the light fitting rotates upwards into final upright position.

Secure the poles back together **using supplied bolt**  **WARNING** and tighten. Unclip second rope and carabiner from bottom of pole.

Secure with a padlock (not supplied)

Unit has now been set up.

To rotate light , loosen U-bolt, twist pole and retighten U-bolt.



Ensure base is filled at all times during use. Failure to fill the base could lead to injury of personal and damage of equipment. MOMA Solar suggest checking the water level every 6 months under normal conditions to ensure the water level is maintained.



WARNING



moma
solar

Head Office

1/3-5 McElligott Court Canning
Vale, WA, 6155

08 6141 3204

info@momasolar.com.au

momasolar.com.au

STOP AND THINK





5. Additional Information

Using the Remote

Mode can be changed via remote, or mode button located on the MOLSX unit. Remotes are universal, require no syncing and can work across several MOSLX units.

To change via the remote, press the corresponding button to the Modes below:

The Power button will turn the light off for one night. The next night the light will turn back on. Light will be set to the most recently chosen mode.

Demo: cycles through all modes

Flash Red Indicating Light | **L**: Lighting control 15hr 70% constant brightness

Orange Indicating Light | **T**: Timing control 5hrs 80%, 10hrs 40%

Green Indicating Light | **U**: Timing & microwave control 5hrs 100%, 10hrs for 30% motion + 10% no motion

Red Indicating Light | **M**: Microwave control 15hrs 80% all night with motion (80% motion, 40% no motion)

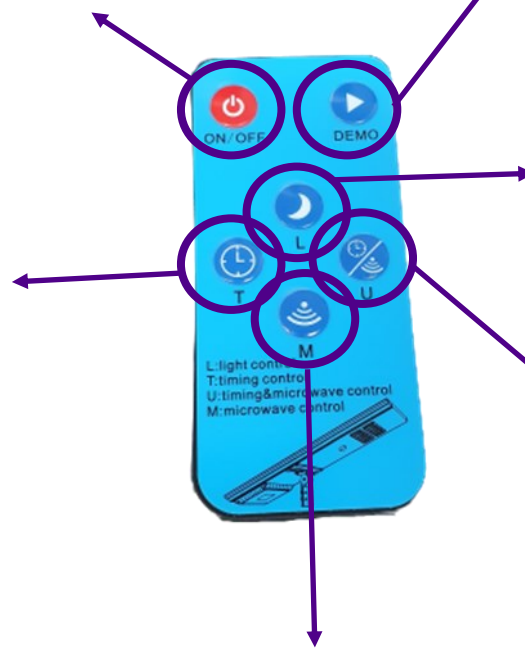



moma
solar

MOMA Solar Pop Up Light Instruction Manual

Common installations errors and Maintenance guide

1. Avoid installing the light under shadowed or shaded areas or between two buildings/surrounding flora which height exceeds the max height of the unit.
2. Do not use the light in environment temperatures above 60 degrees Celsius or below -10 degrees Celsius, otherwise this could cause a rapid attenuation of the battery and affect the battery life.
3. Please ensure all safety equipment and precautions are followed when installing the light.
4. Choose the suitable lighting mode according to local sunshine. Keep the device away from fire and oil to avoid any fire or explosion.
5. If the light does not receive charge for 10 days, the battery maybe out of power. In this instance, please charge the battery under bright sunlight to ensure the maximum battery life. Unit will need to be turned on during this charging period.
6. In order to ensure that the light works in an ideal state for a long time, please clean the solar panel regularly according to the local dust conditions. Our suggestion is annually in normal conditions, or once every 3 months in high dust conditions.



Head Office

1/3-5 McElligott Court Canning
Vale, WA, 6155

08 6141 3204

info@momasolar.com.au

momasolar.com.au

STOP AND THINK





MOSLX Troubleshooting Guide

The MOSLX solar street light is mainly composed of four parts:

- 1- Solar Panel,
- 2- Batteries,
- 3- LED lights,
- 4- Solar Controller.

Failure of these main four parts will cause the entire system to fail, and the LED lights will not be able to function at night. The MOSLX fault guidelines are based on the above 4 parts. The MOSLX Solar controller is the core part of the light which connects solar panel, batteries and LED lights, and controls the operation of the entire system.

There is an indicator light on the controller (microwave sensor), which can indicate the running status of the entire system, and it can be quickly determined which step may be the issue.

When the MOSLX solar street light has not been operating for a period of time (LED has not worked during night period), it can be observed by the indicator light on the solar controller LED at night or in daylight (solar panel is covered) to help identify the fault. The indicator light on the controller can indicate the solar light status, as shown in Table 1.



Please ensure unit is **TURNED ON** before troubleshooting begins. The power button should be **FLUSH**. If button is **PRESSED IN** the units is **OFF**.



If any parts of the unit have obtained **physical damage** the unit will **not function efficiently**. Please contact **MOMA Solar** in regards to availability of spare parts.

Mode	Status	State
1	No Light	System off or system voltage fault
2	Green	Working Mode
3	Red	Working Mode
4	Orange	Working Mode
5	Red flashing (0.5HZ)	Working Mode
6 - 7	Red flashing (1HZ)	Load open circuit
8 - 9	Green flashing (1HZ)	Charging normally
10	Red Light but Green flashing (1HZ)	Battery over discharge, and it is charging
11	Red and Green flashing (2HZ)	Battery over discharge

Table 1 – Controller indicator status description



Head Office

STOP AND THINK





moma
solar

MOMA Solar Pop Up Light Instruction Manual

- When the indicator is in Mode 1 (table 1), it may be a battery or solar controller failure. Please contact MOMA Solar on advice for resolving the fault. The above fault can be checked by testing with a Multi-meter to detect the battery voltage. Battery failure can be eliminated if the battery voltage is normal (the battery voltage range should be 10V~13.2V DC). Should the failure not come from the battery, the controller may have to be replaced.
- When the indicator is in mode 6 (table 1) it may be due to one of the 3 reasons stated below:
 1. Faulty or loose connection between LED and Solar Controller,
 2. LED is faulty,
 3. Controller is faulty.

Please check the connection between the Controller and the LED. The light can be turned on normally 20 seconds after checks performed. Should the LED still not operate, the replacement of the solar controller and LED needs to be carried out. Please contact MOMA Solar for replacement parts.

- When the indicator is in mode 7, it may be a short circuit between the Solar Controller and LED which indicates that either the LED or solar controller is faulty. Please contact MOMA Solar for replacement parts.

One method to check is to disconnect the wiring between the Solar Controller and the LED, if the indicator light flashes as per mode 6 (table 1) after 20 seconds of disconnection, check with multi-meter whether the LED connector is short-circuited or not. If there is a short circuit on the connection between controller and LED then the LED is faulty. At this time, please replace entire LED board, LED can be turned on normally after 20 seconds. If there is no short-circuit, replace the Solar Controller.

Continued over page.



moma
solar

Head Office

1/3-5 McElligott Court Canning
Vale, WA, 6155

08 6141 3204

info@momasolar.com.au

momasolar.com.au

STOP AND THINK





moma
solar

MOMA Solar Pop Up Light Instruction Manual

- When the indicator mode is mode 8, 9 or 10 (table 1) the check methods for these three modes are the same. Firstly, if there is a light source shining on the solar panel, please remove the nearby light source and wait for 2 minutes and check the indicator for mode type. If there is no nearby light source shining on the solar panel, please contact MOMA Solar for replacement Solar Controller.
- When the indicator mode is mode 11, it may be the battery, solar panel failure or controller failure.

Please use a multi-meter to detect the battery voltage, if the battery voltage is greater than 12V, please contact MOMA Solar for replacement parts. Reconnect the connection between battery and controller, observe whether the light can function normally. If LED light still does operate and the indicator shows the state of mode 11, please contact MOMA Solar for replacement parts.

If the voltage of the battery is less than 12V, please replace battery, and then observe whether the fault still exists or not. If the fault still exists use a multi-meter to measure the voltage from the solar panel whilst in the sun to determine whether if it is a solar panel failure. If there is no voltage from the solar panel this will require replacement, please contact MOMA Solar.

**The above information is the most common failure analysis, it does not include all failures.
If there are any other fault conditions, please contact MOMA Solar**

**Having Troubles?
Call Us 08 6141 3204**



moma
solar

Head Office

1/3-5 McElligott Court Canning
Vale, WA, 6155

08 6141 3204

info@momasolar.com.au

momasolar.com.au

STOP AND THINK





moma
solar

MOMA Solar Pop Up Light Instruction Manual

6. MOSLX Solar Street Light Specs



	MOSLX-20W	MOSLX-30W	MOSLX-40W	MOSLX-60W	MOSLX-80W	MOSLX-100W
LED CCT	3000-6500K					
Monocrystalline Solar Panel	28W	35W	40W	55W	72W	85W
Battery Voltage	Rated Voltage:12.8V					
Battery Cycle	2000+ Cycles					
Charge Time	6~8 hours					
Working time	15hrs/Day, Light + Time + Microwave Sensor Control					
Intelligent Controller	12V 10A MPPT Charge Controller with Microwave Sensor					
Inbuild Protection	Over Charge, Discharge, Heat and Over Load Protection					
IP Rating	IP65					
Material	Aluminium + Tempered Glass					
Working Temperature	-10°C to 60°C					
Warranty	3 Years					
Installation Height	3~6m	3~8m	4~8m	6~14m	8~14m	8~16m
Weight	6KG	7.5KG	8.5KG	10.5KG	15KG	18KG
Dimensions	710*310*90mm	840*310*90mm	970*310*90mm	970*400*90mm	1180*400*100mm	1450*400*100mm

LIFEPO4 VS LI ION

Over 2000 cycles		Over 500 cycles
Extremely low Explosion risk		Very High Risk Explosion in High Temperature
-10 to 60 Degree		0 to 45 Degree
Up to 7 Years		24 to 32 Months



moma
solar

Head Office

1/3-5 McElligott Court Canning
Vale, WA, 6155

08 6141 3204

info@momasolar.com.au

momasolar.com.au

STOP AND THINK



Lighting Council
AUSTRALIA MEMBER

