

Siebel Si 204D

'German Transport and Trainer Plane'

EN

In 1934 in the German city of Halle, Hanns Klemm, an aircraft designer and manufacturer, set up a branch of his aircraft factory. The new plant was to produce multi-engined, all-metal aircraft, in contrast to the original factory where wood was still being used for building the aeroplanes. In 1937, the Halle plant was taken over by the famous German aviator Friedrich Siebel who also gave it his name. The plant mainly focused on licence-built designs, but had a couple of their own aircraft designs too. The first type to be produced by this new plant was the Fh 104 Hallore, a design in fact originating in the Klemm works.

In 1938, Germany's flag carrier Deutsche Luft Hansa in cooperation with the RLM announced tender for a fast, twin-engined transport aircraft. Before the winning design could be found, the war had broken out which meant the new type would be used just (or mainly) by the German military. The prototype Si 204A first flew on 23 May 1941, being of an all-metal construction and powered by a pair of Argus As 411 engines and differed from all later versions by having a stepped pilots' canopy. Its production was commenced at the Halle plant at first but as their workers were busy with producing Ju 88 bombers, the production was later transferred to the French Société Nationale de Constructions Aéronautiques du Nord (SNCAN). The third prototype machine was finished as the new Si 204D version which had completely glazed pilots' office similar to that of the He 111H/P and Ju 88A bomber aeroplanes and in this new configuration, the type perfectly suited to the trainer role. The Si 204D was produced not just by the French plant, but in the Protectorate of Bohemia and Moravia (former Czechoslovakia) by Aero, Letov and CKD factories too. The final variety to be developed during the war time was the Si 204E which featured a gun turret and bomb bay in the central section of the fuselage, enabling the type to take part in the bomber crew training or it was even used as a makeshift night fighter. The German Luftwaffe operated the Siebel mainly in so-called B- and C- flight training schools and as a liaison aircraft. The machines which were fitted with radar equipment were used for night fighter training and a handful of the Si 204 was also operated by the Deutsche Luft Hansa during the war.

The end of the Second World War did not bring the career of the type to its end, the Siebel proved to possess marvelous flying capabilities, was reliable and also quite efficient. Several of the Si 204 was taken over by the victorious Allies and were test flown by or even put to regular service with the British RAF, USAAF, Soviet air force, Aeroflot (Soviet Airlines), Czechoslovak air force, ČSA (Czechoslovak Airlines) and French Armée de l'Air and Aéronavale. The post war production went on at both the French SNCAC and Czechoslovak plants. The French machines were known as the NC700 to NC702 and dubbed the Martinet and were also exported to Sweden and Poland. In Czechoslovakia, the various indigenously built versions of the Siebel were put to service as the C-3A/B, C-103 or D-44 respectively. At first, they were to serve for training purposes only, but the 1948 communist coup and various other reasons too meant that no other and more advanced types would be available to replace them eventually, so they went on to serve with the bomber units of the ČSLA (Czechoslovak Air Force) well until the mid 1950s when they were replaced by the Il-28 jets.

Si 204D characteristics and performance:

Wingspan 21.28 m, length 11.95 m, max. speed 364 km/h at 3,000 m, service ceiling 7,500 m, range 1,800 km.

CZ

V roce 1934 založil Hanns Klemm v Halle pobočku své firmy. Ta měla vyrábět, na rozdíl od mateřské továrny, vyrábějící celodřevěné letouny, vícemotorové letouny celokovové konstrukce. V roce 1937 převzal továrnu v Halle známý německý letec Friedrich Siebel a přenesl na ni své jméno. Továrna se zabývala hlavně licenční výrobou, ale konstruovala i vlastní typy. První konstrukcí nové továrny se stal Fh 104 Hallore, který vznikl ještě jako projekt v továrně Klemm.

V roce 1938 vypukla dopravní společnost Lufthansa ve spolupráci s RLM soutěž na rychlý dvumotorový dopravní letoun. Než byla soutěž ukončena, vypukla válka. O letoun ale jevila stále zájem Luftwaffe. Prototyp letounu označeného Si 204A vzlétl poprvé 23. 5. 1941. Tento dvumotorový celokovový letoun byl poháněn dvojicí motorů Argus As 411 a od všech pozdějších verzí se odlišoval tím, že měl stupňovou před. Byl zaveden do výroby, ale protože továrna v Halle byla vytížena výrobou Ju 88, byla výroba přenesena do Société Nationale de Constructions Aéronautiques du Nord (SNCAN) ve Francii. Třetí prototyp byl vyroben jako nová verze Si 204D. Odlišoval se celoprosklenou přední, podobnou jakou byly vybaveny bombardovací letouny He 111 H/P nebo Ju 88A. Hodil se tak skvěle k výcviku. I jeho výroby byla předána do SNCAN ve Francii a také do továrny Aero, Letov a ČKD v Protektorátu Čechy a Morava. Poslední verzi vyvinutou za války byla Si 204E, vybavená střeleckou věží a pumovnicí v centroplánu. Ta byla určena k bombardovacímu výcviku. Nouzově mohla být použita i jako noční bombardér. Luftwaffe používala Si 204 hlavně v tzv. B a C školách a jako spojovací. Stroje vybavené radarem sloužily k výcviku nočního stíhání. Několik kusů používala během války i Lufthansa.

Konec války ale neznamenal konec historie Si 204. Siebel Si 204 měl skvělé letové vlastnosti, byl spolehlivý a výkonný. Dost letounů zabavili vítězové. Ukořistěné Si 204 tak testovaly nebo používaly britská RAF, USAAF, sovětské letectvo i Aeroflot, Československé letectvo i ČSA a francouzské Armée de l'Air i Aéronavale. Výroba ve Francii u SNCAC pokračovala i po válce, stejně jako v Československu. Ve Francii vyráběný Si 204 v několika verzích byl označen NC 700 až 702 pojmenován Martinet. Byl dokonce exportován do Švédska a Polska. Československé Si 204 byly označovány podle verze C-3A/B, C-103 a D-44. Jejich výroba pro nově budované československé letectvo i státní aerolinie ČSA se rozeběhla hned po válce. Měly být používány jen k výcviku. Díky komunistickému převratu a nemožnosti je nahradit z různých důvodů jinými typy tvořily ale výzbroj bombardovacích jednotek ČSLA až do jejich náhrady proudovými Il-28 v polovině padesátých let.

Si 204D TTD

Rozpětí 21,28 m, délka 11,95 m, max. rychlost 364 km/h ve výšce 3 000 m, praktický dostup 7 500 m, dolet 1 800 km.

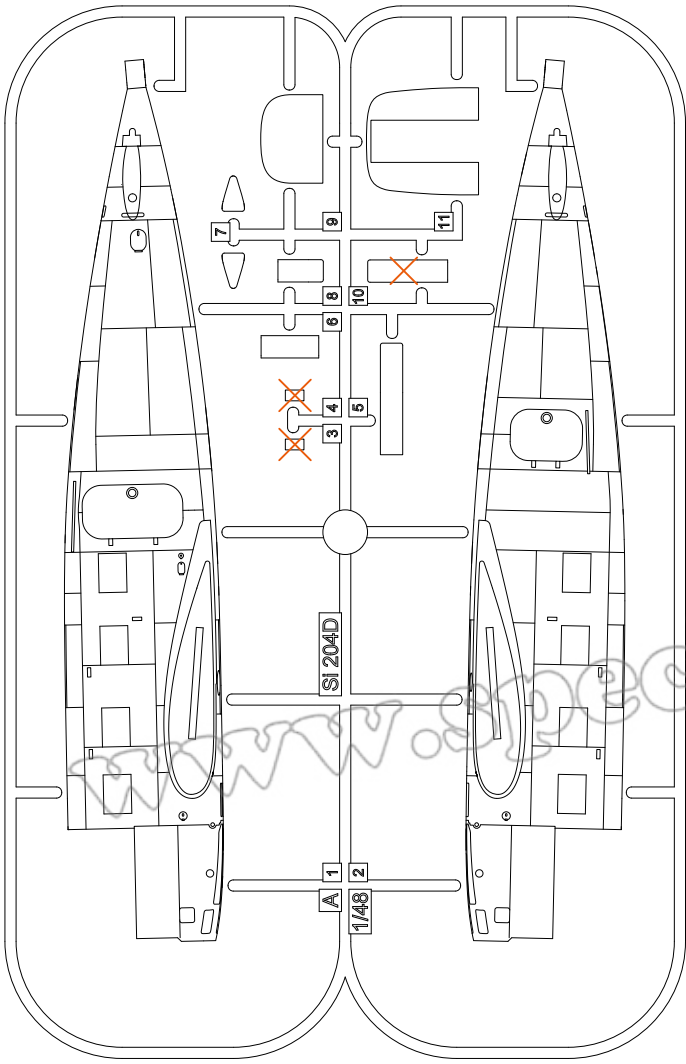

A B

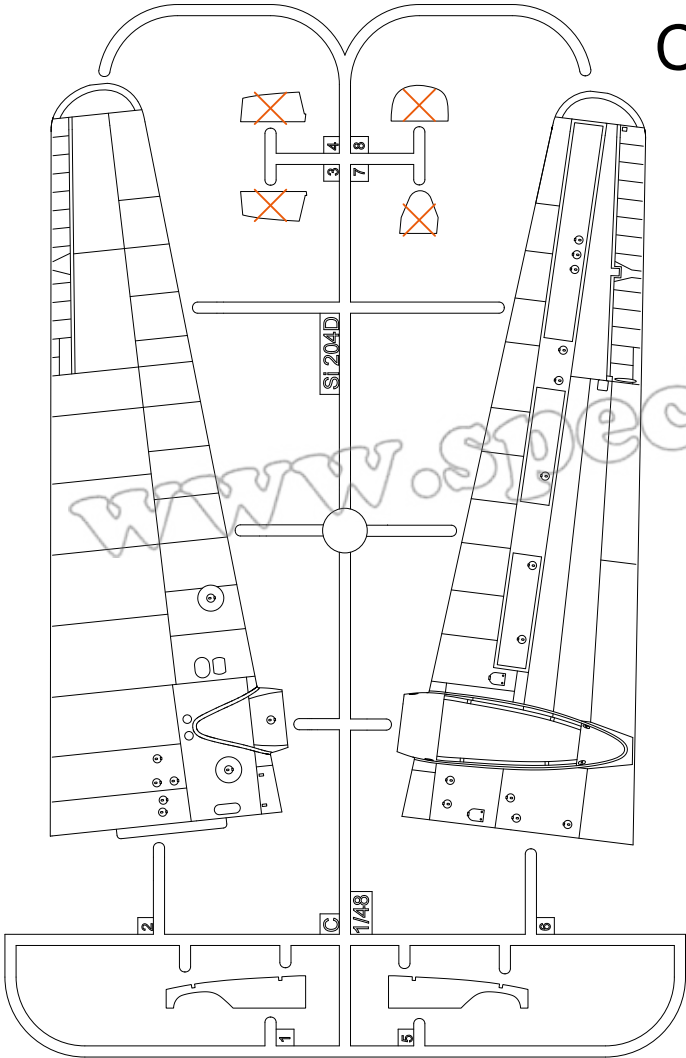
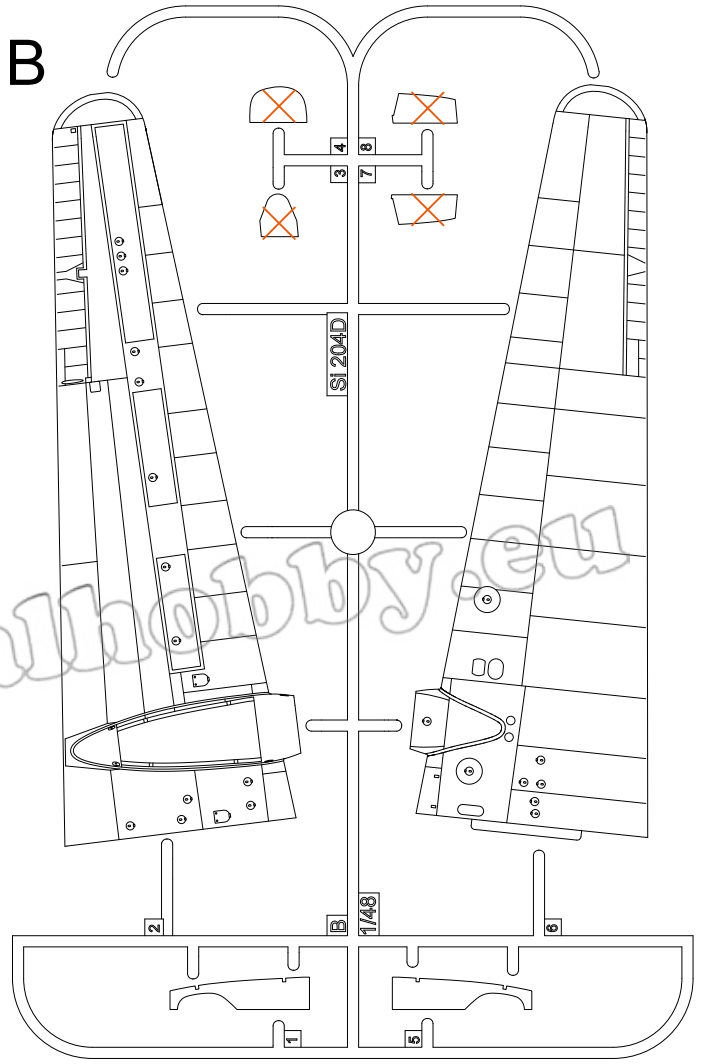

C D

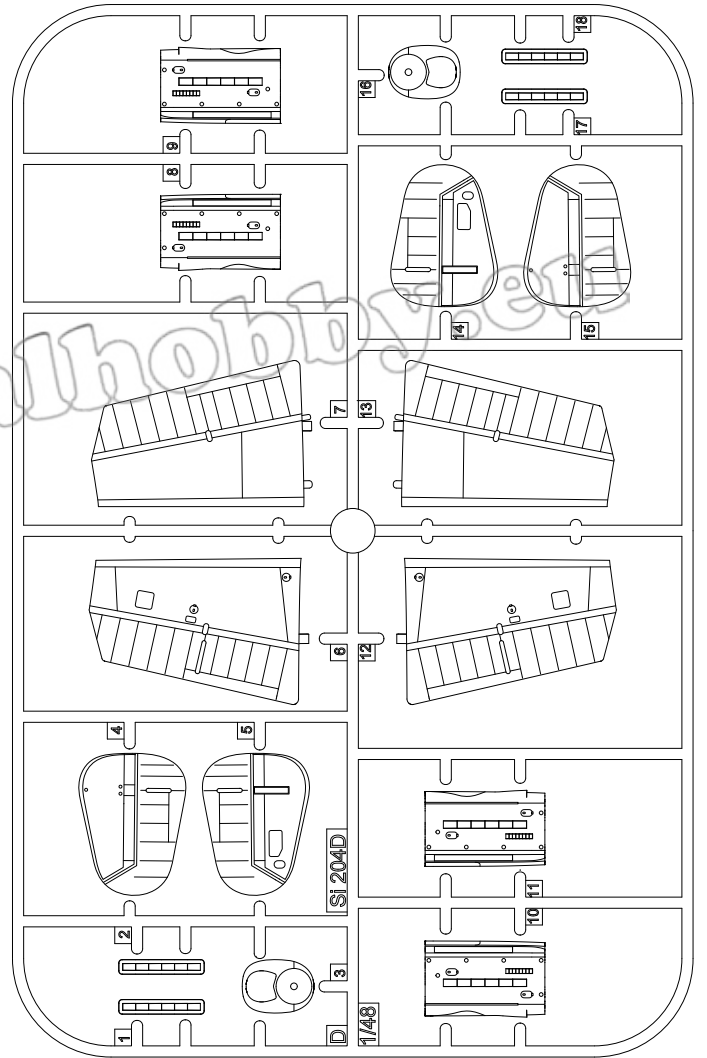

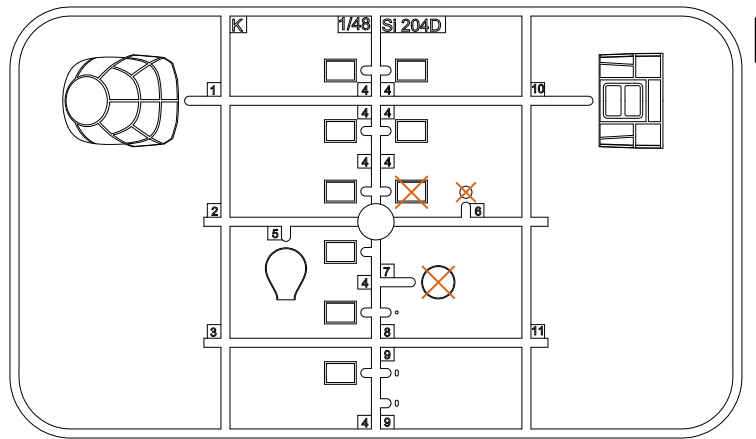
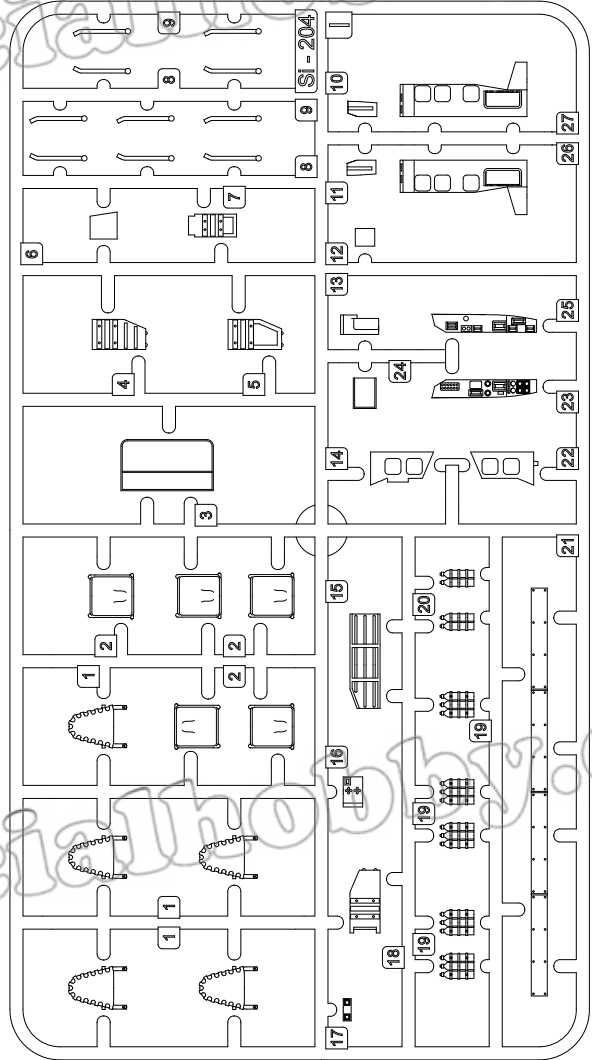
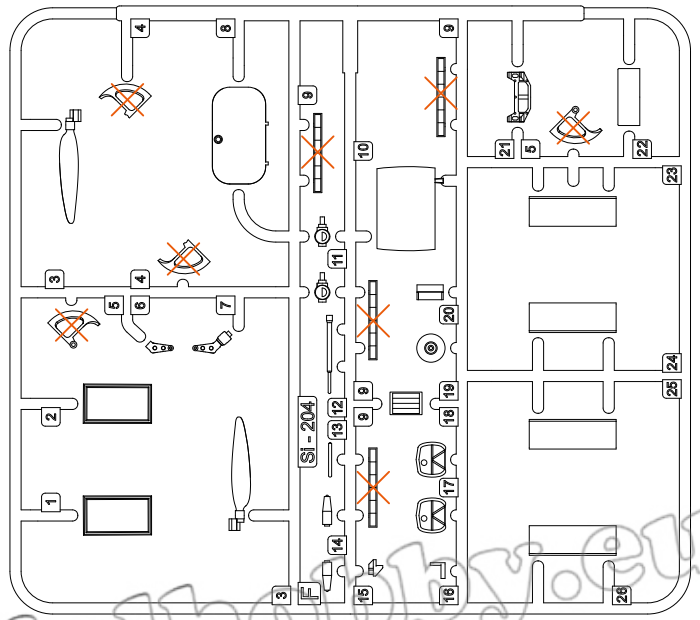
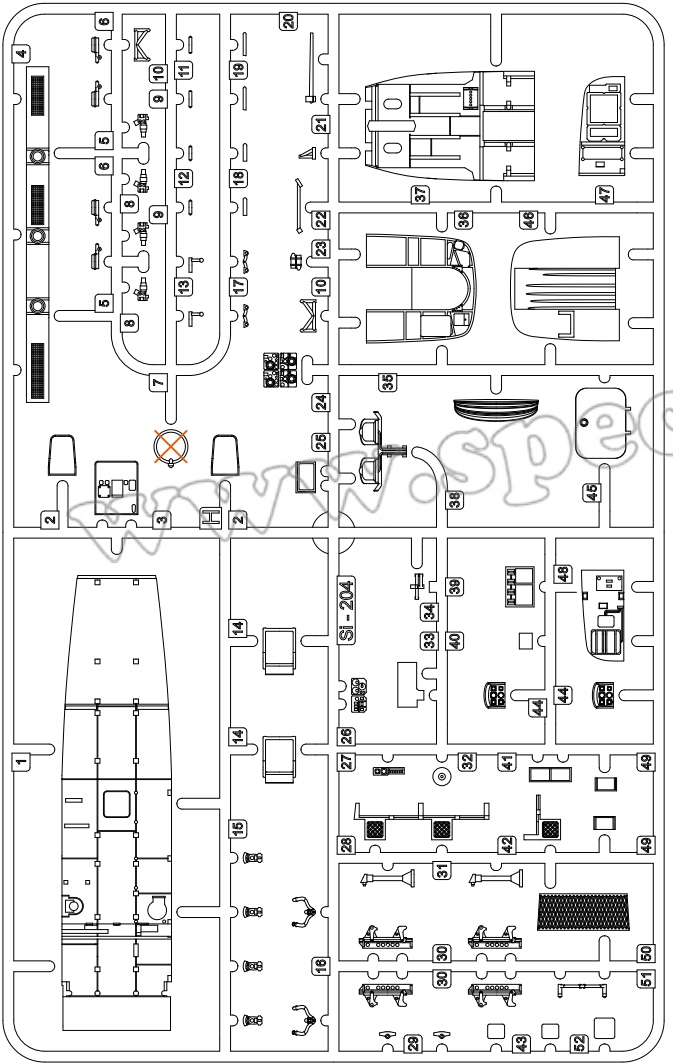
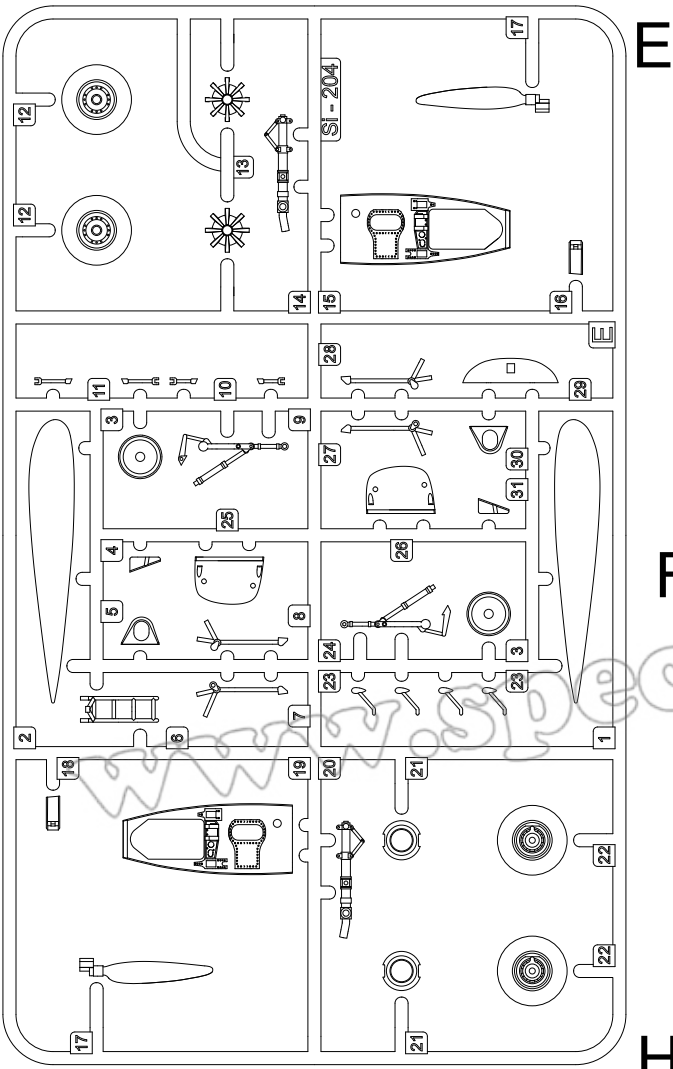

PUR1

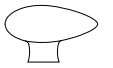

K

STEP 1a

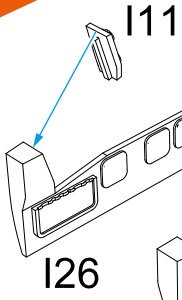

STEP 1b

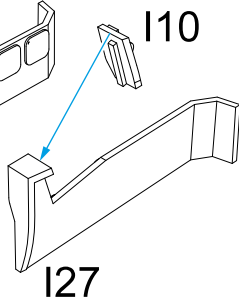

STEP 2a

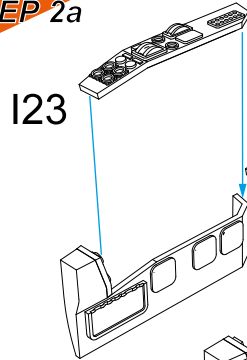

STEP 2b

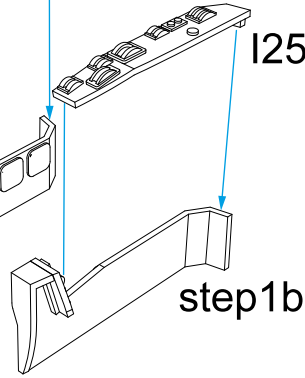

STEP 3

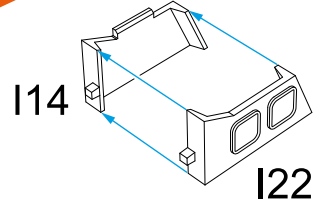

STEP 5

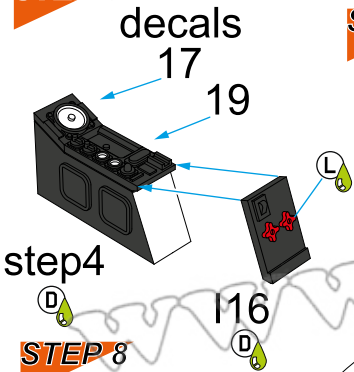

STEP 6

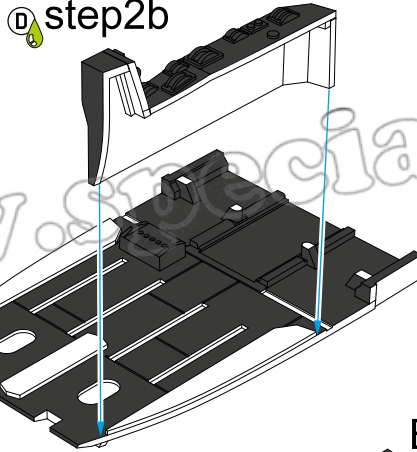

STEP 7

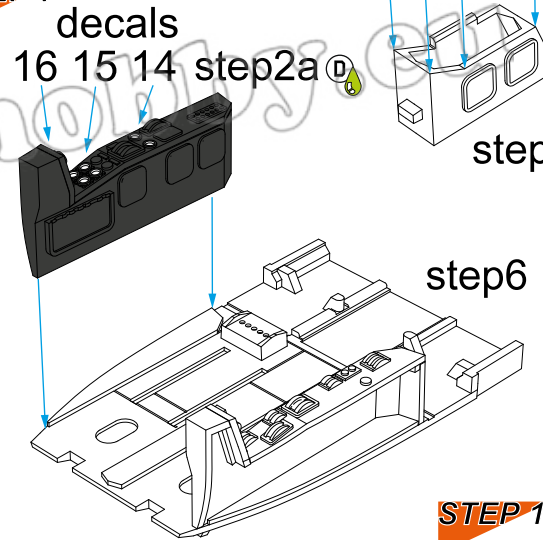

STEP 4

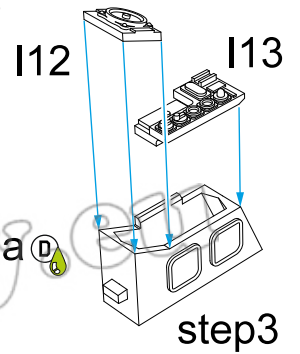

STEP 8

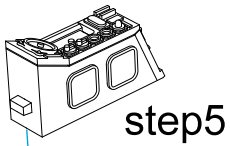

STEP 9

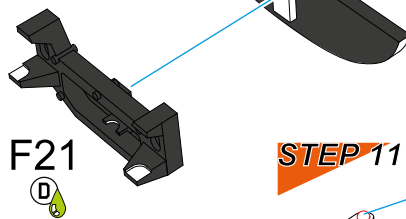

STEP 10

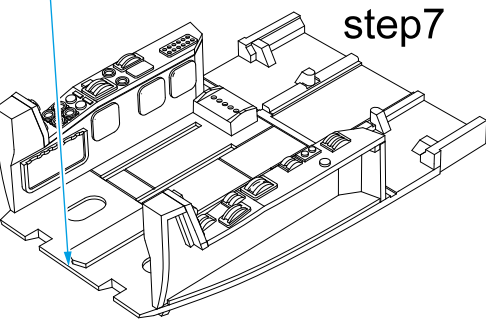
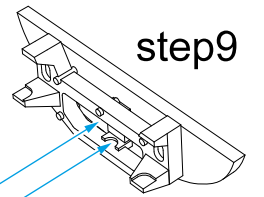

STEP 11

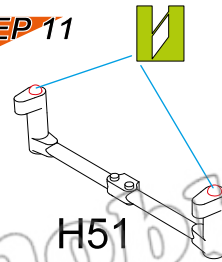

STEP 12

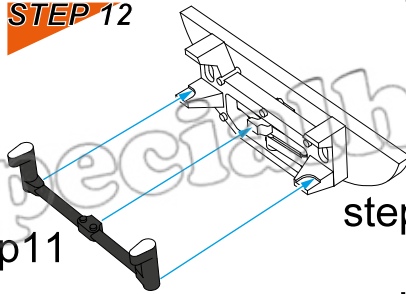

STEP 17



STEP 13

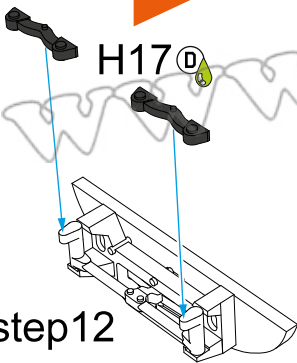

STEP 15

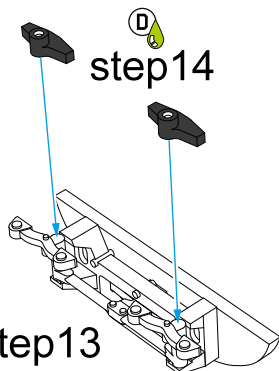

STEP 16a

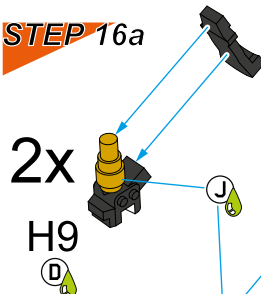

STEP 16b

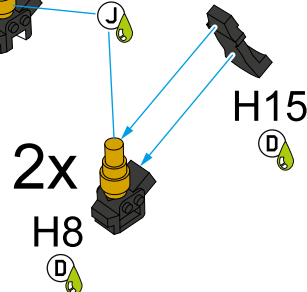

STEP 14

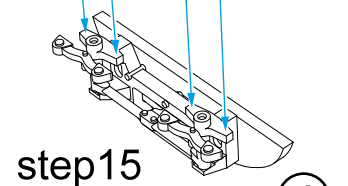
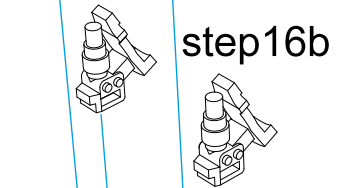
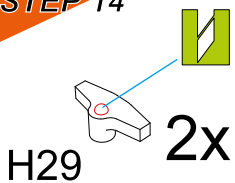

STEP 18

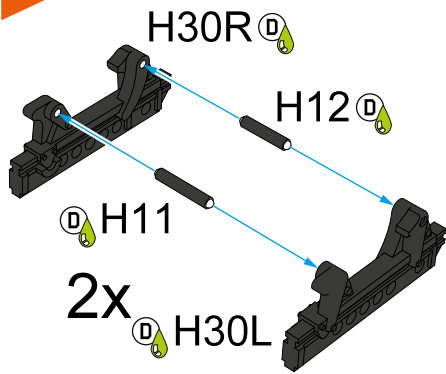

STEP 19

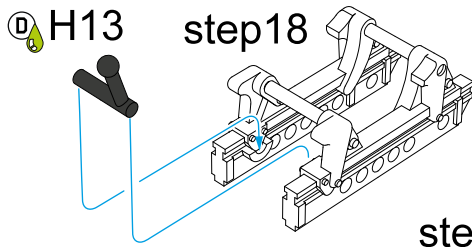

STEP 20

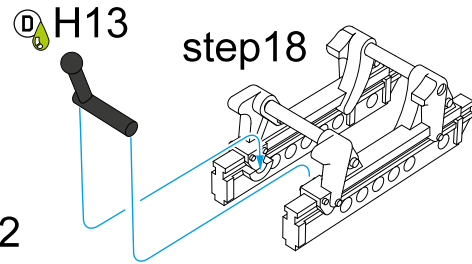

STEP 21

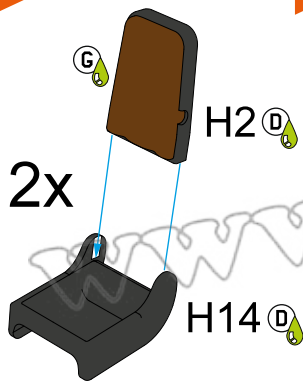

STEP 22

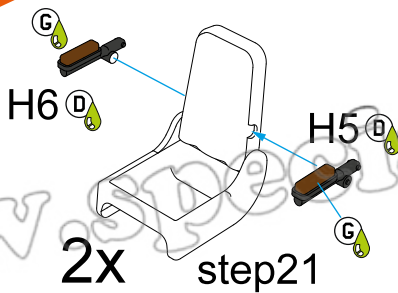

STEP 23

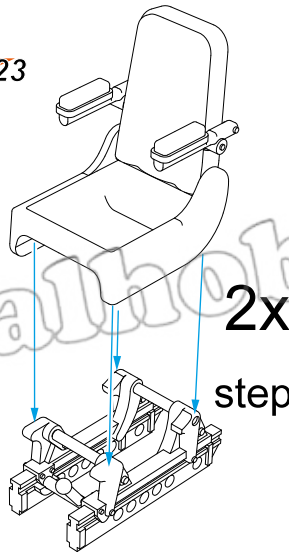

STEP 24

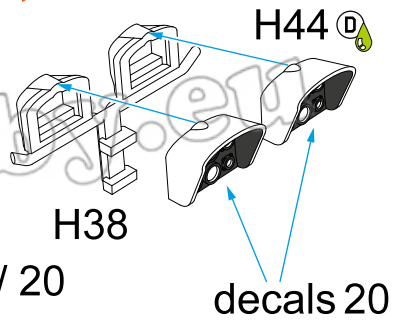

STEP 25

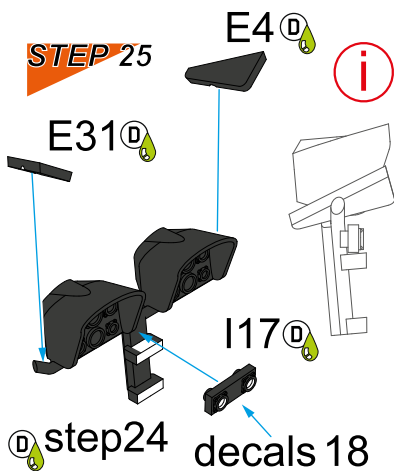

STEP 26

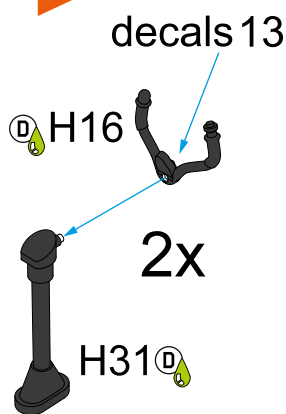

STEP 27

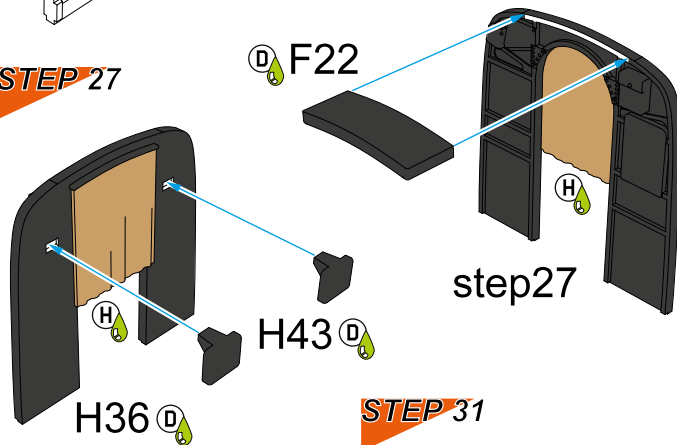

STEP 28

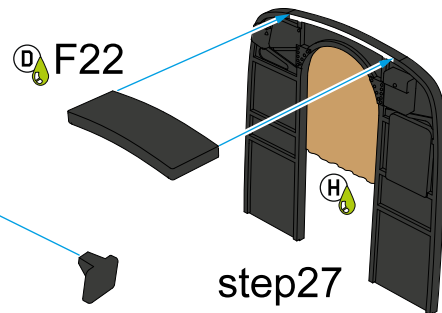

STEP 31

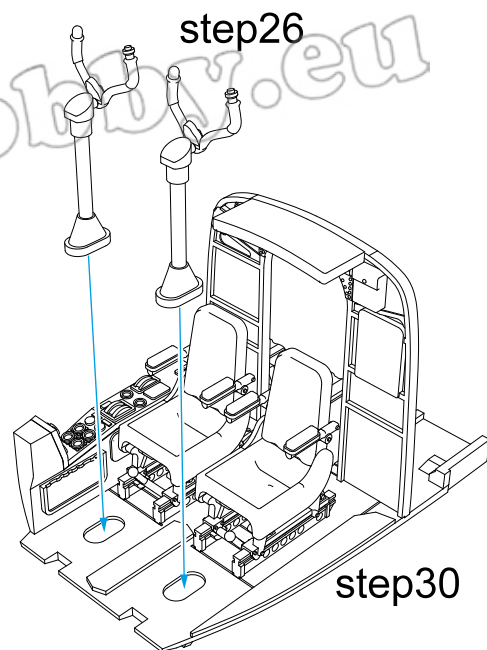

STEP 29

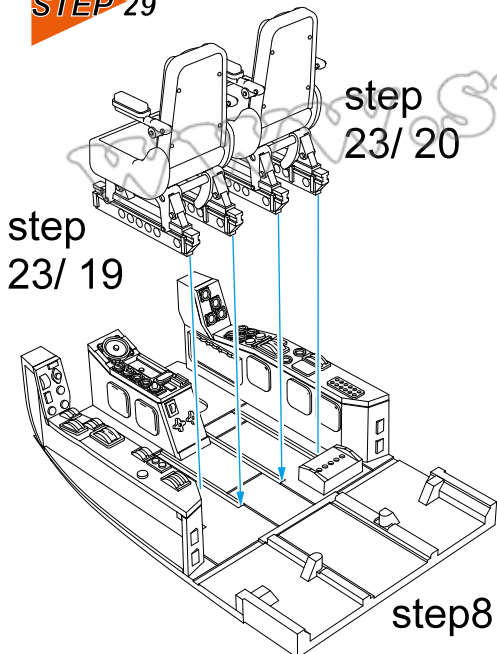

STEP 30

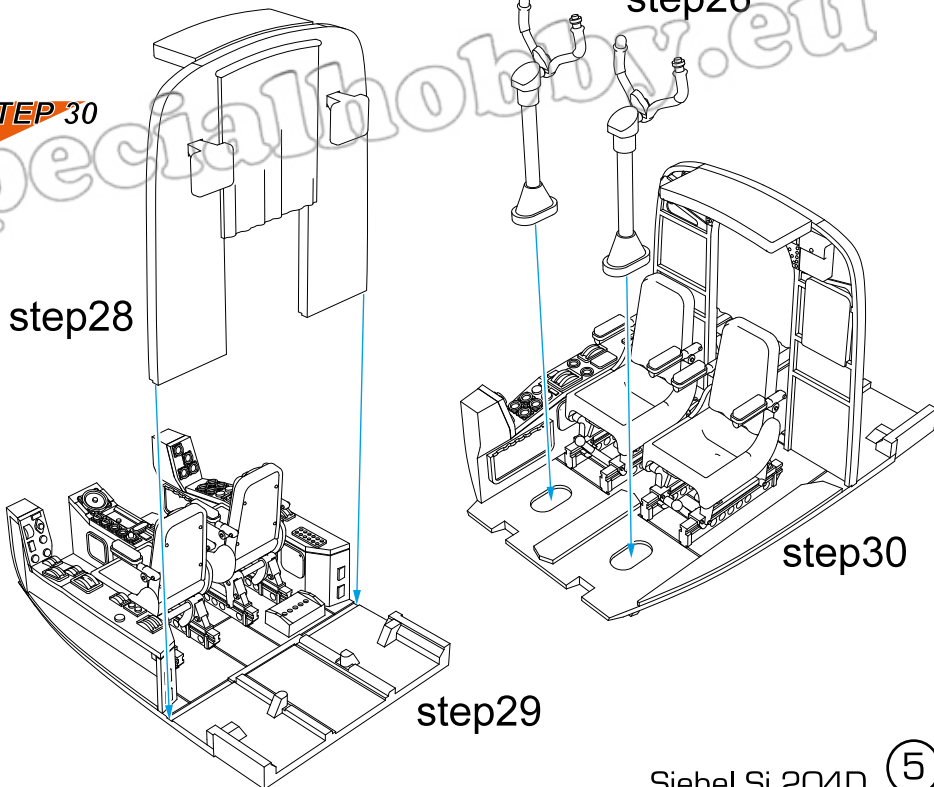

STEP 32

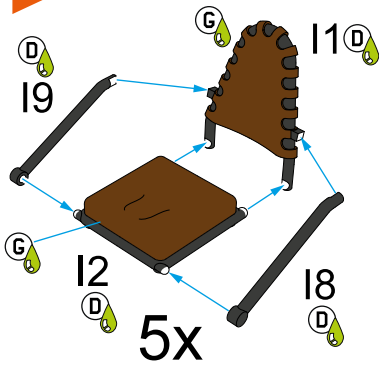

STEP 33

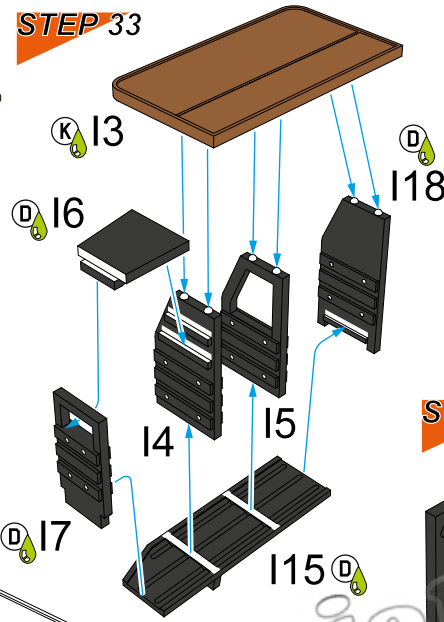

STEP 34

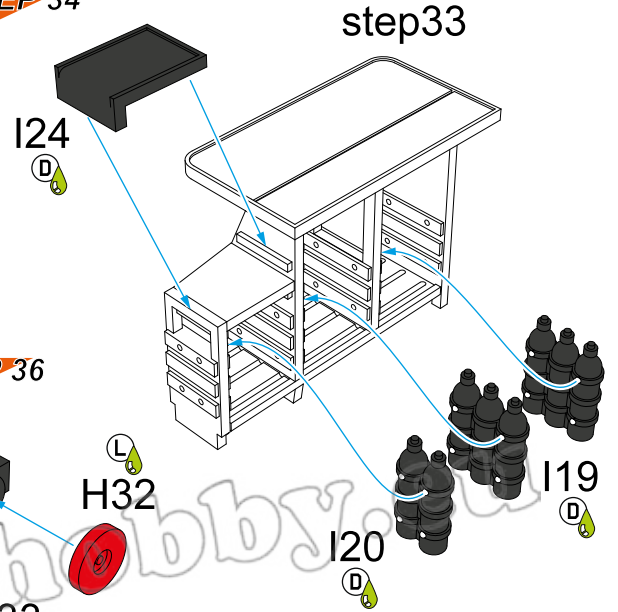

STEP 35

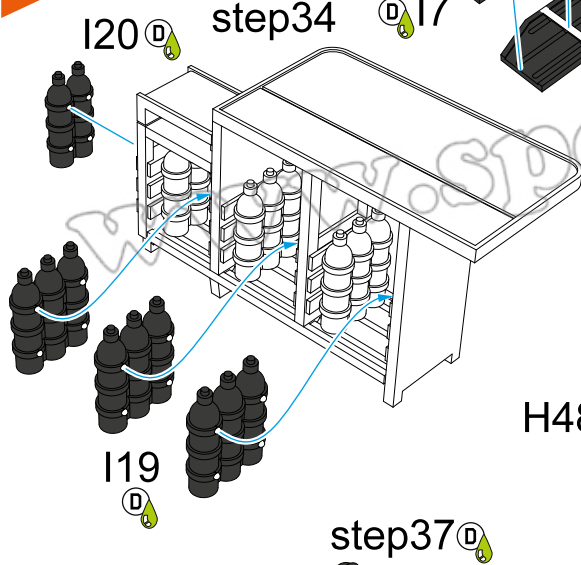

STEP 36

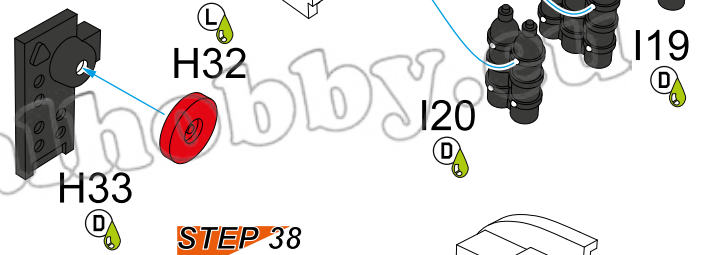

STEP 37

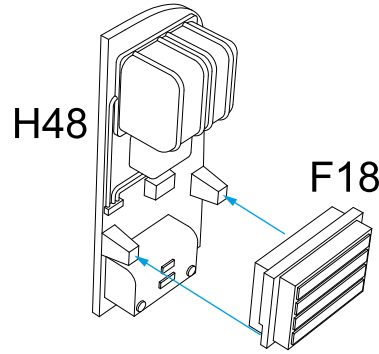

STEP 38

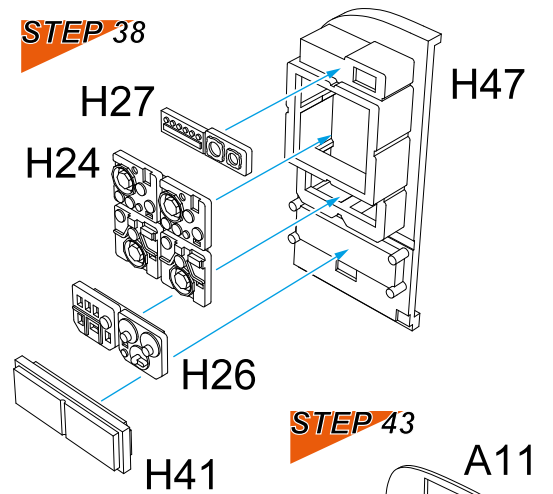

STEP 39

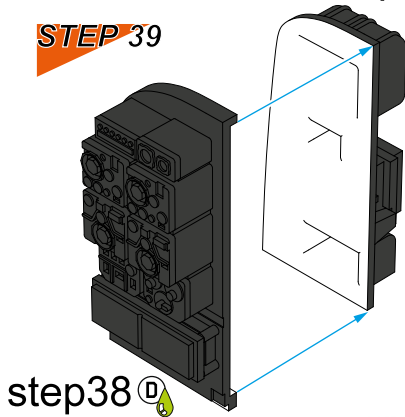

STEP 43

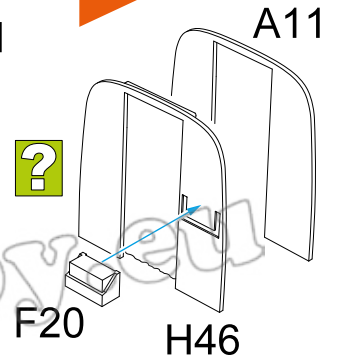

STEP 42

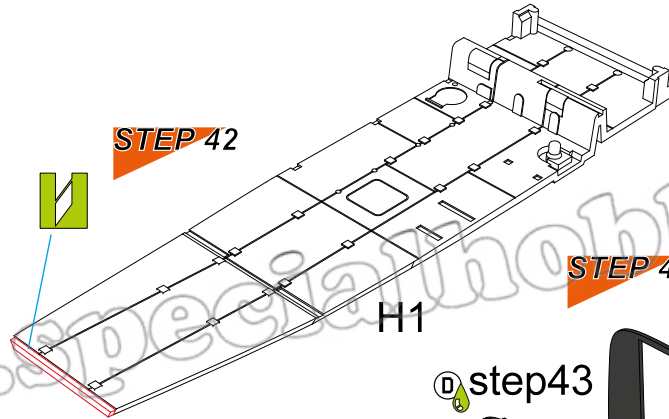

STEP 44

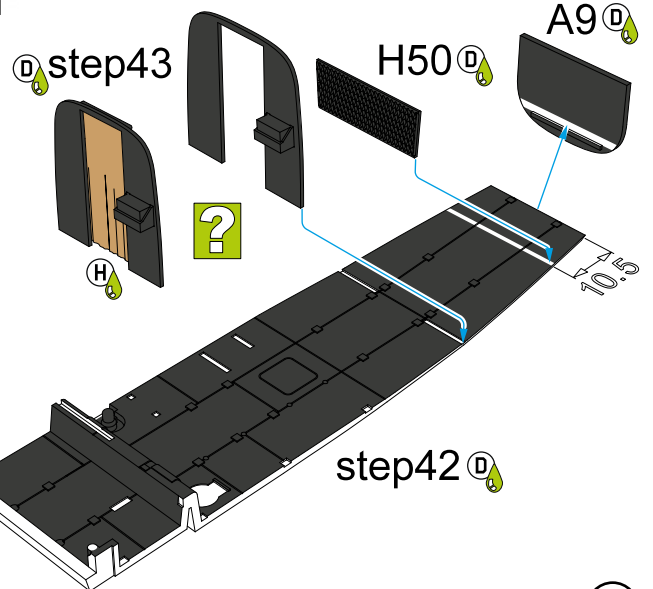

STEP 40

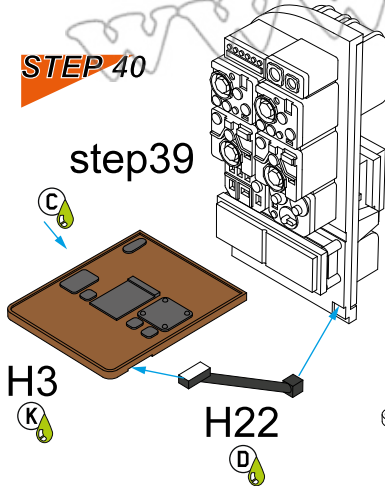

STEP 41

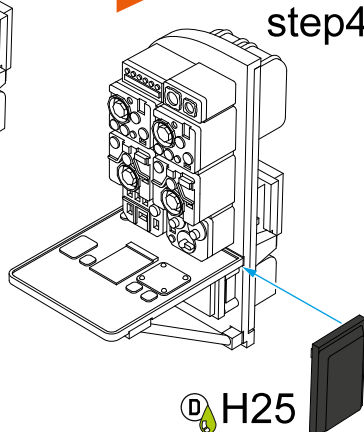

STEP 45

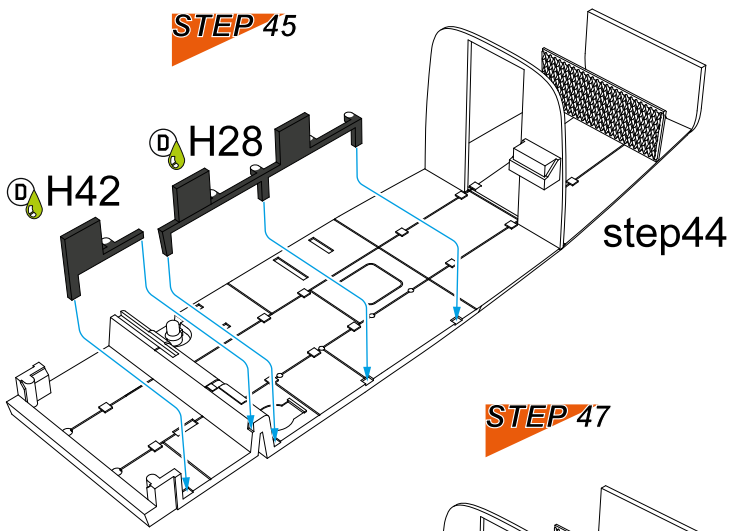

STEP 46

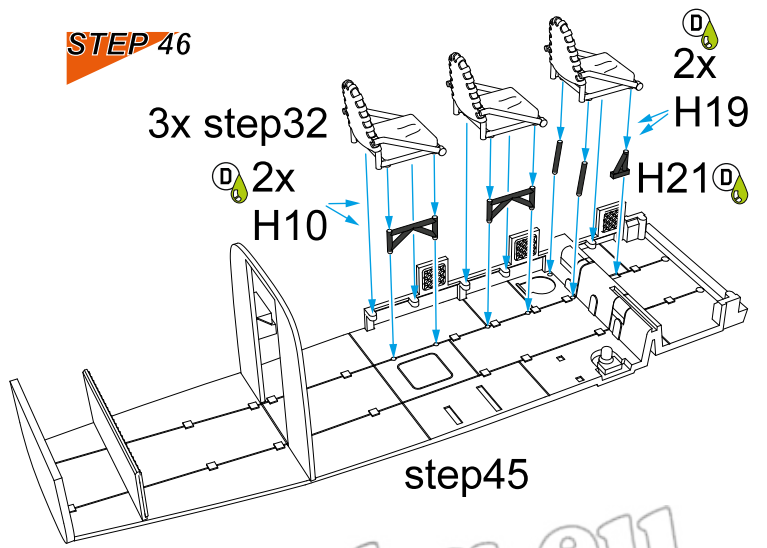

STEP 47

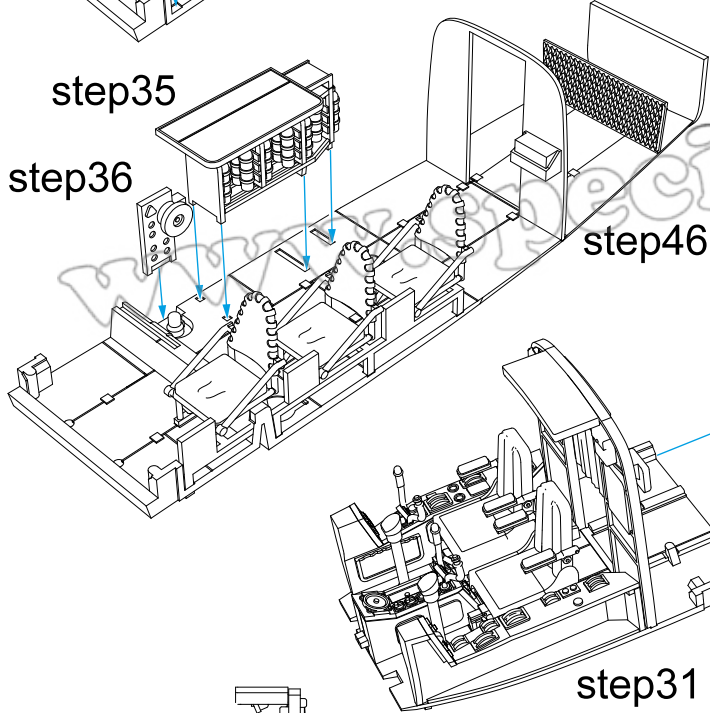

STEP 48

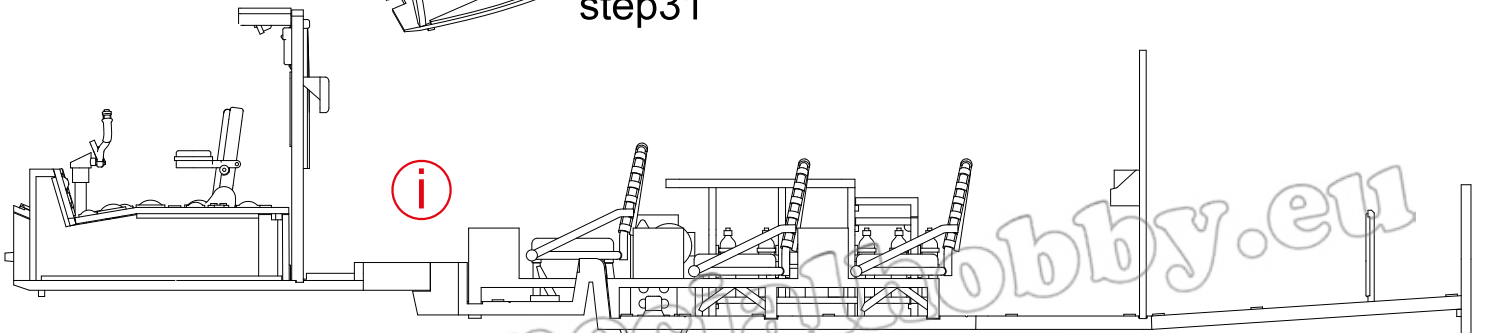
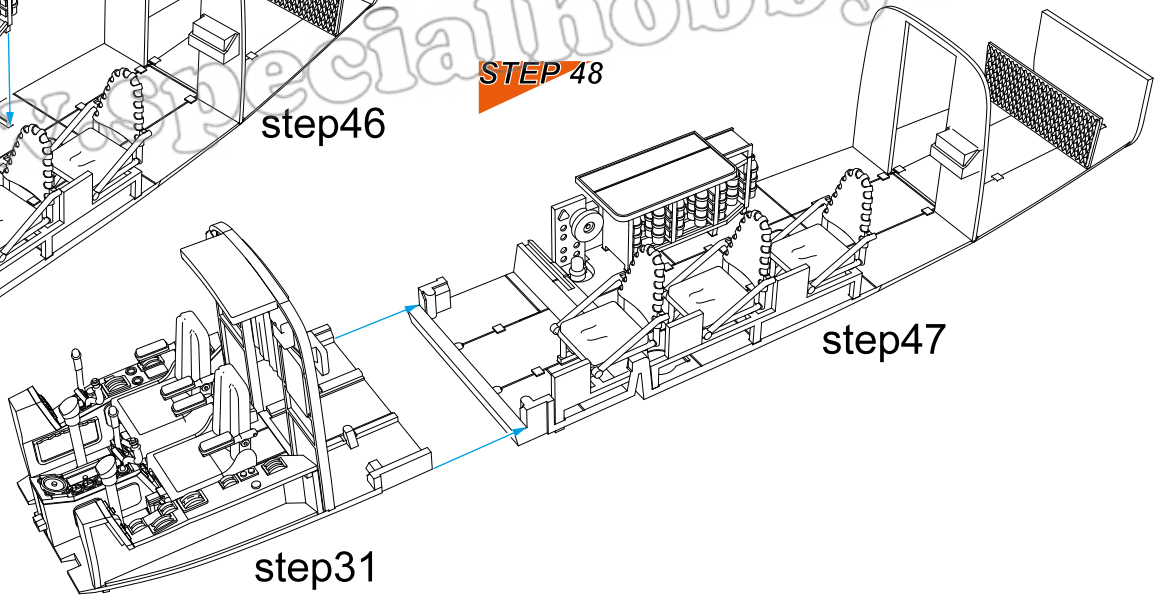

STEP 49

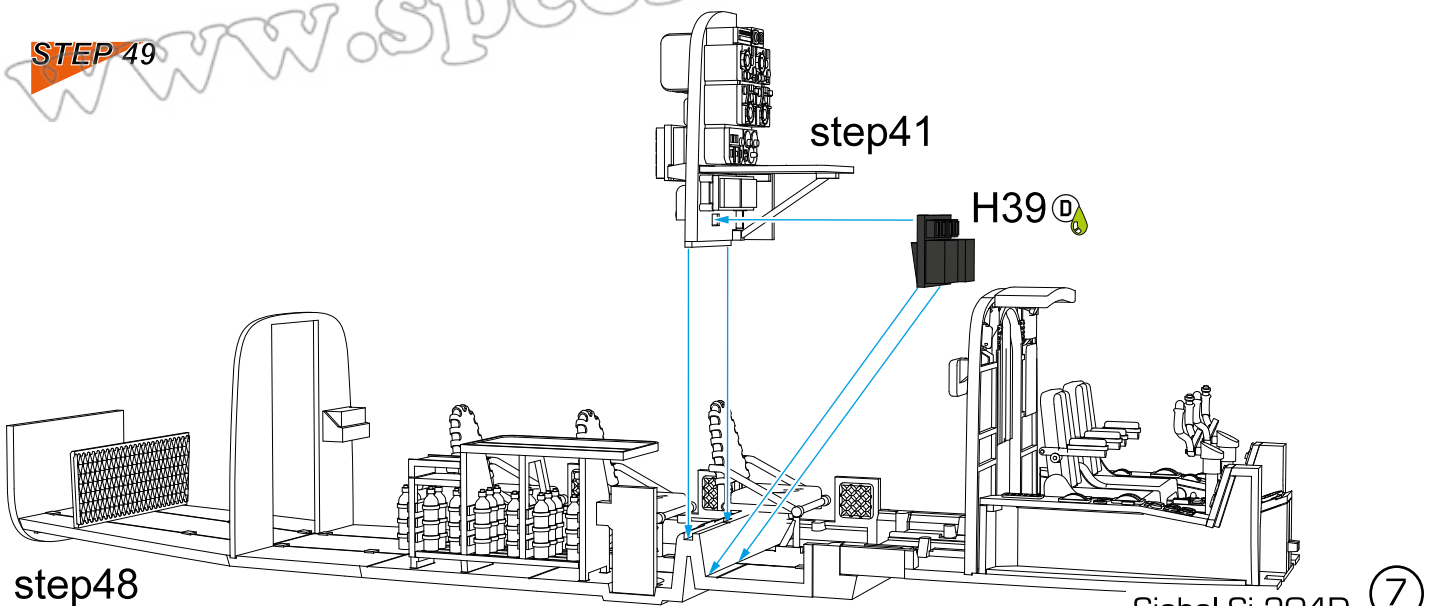

STEP 50

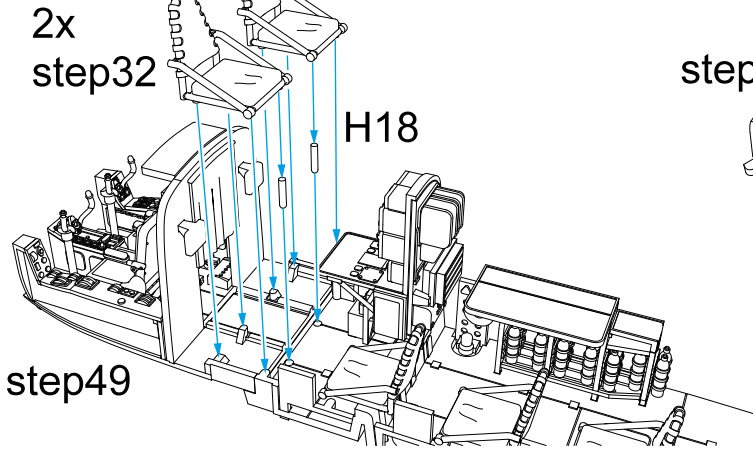

STEP 51

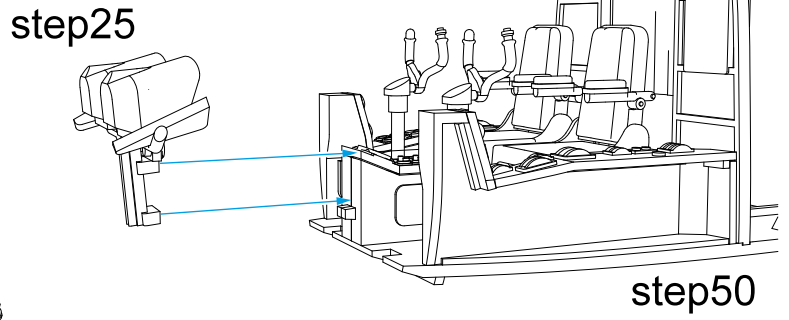

STEP 52

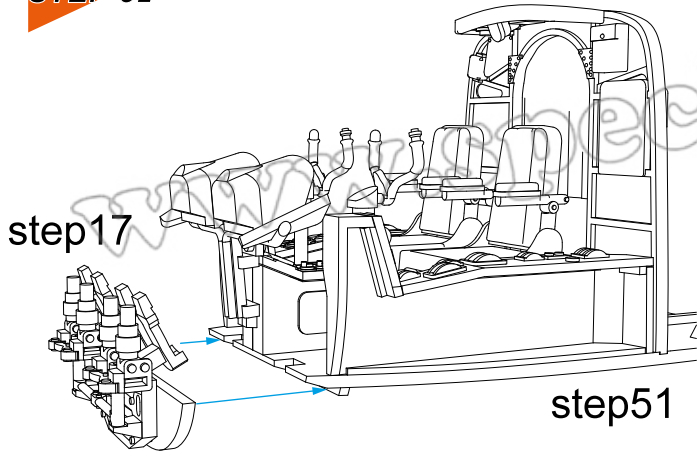

STEP 53

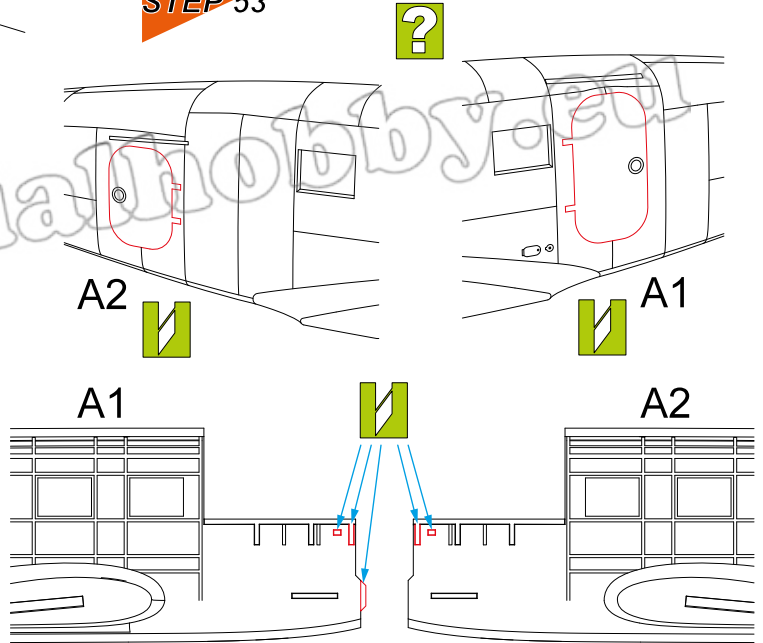

STEP 54

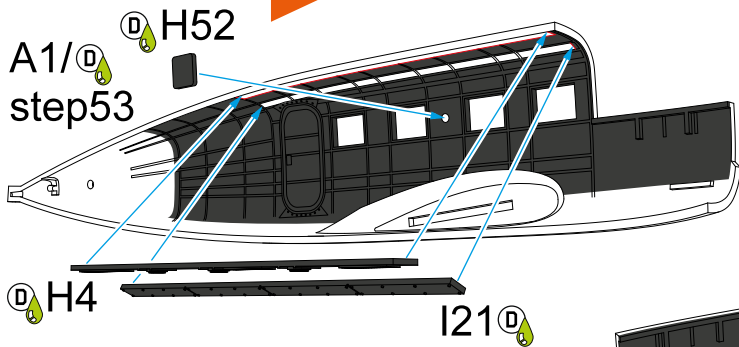

STEP 55

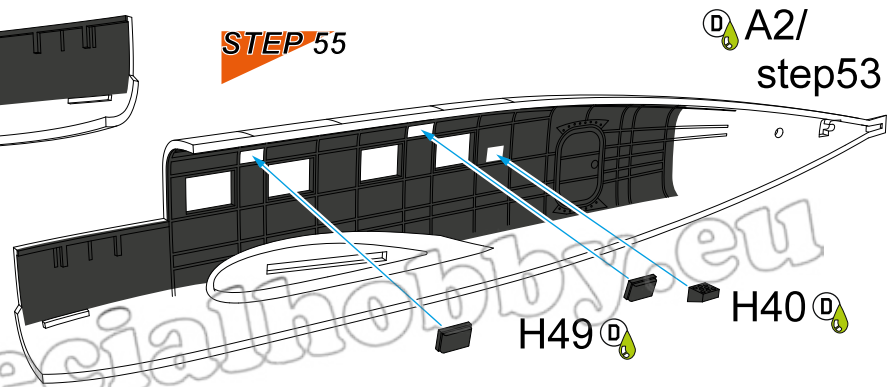

STEP 56a

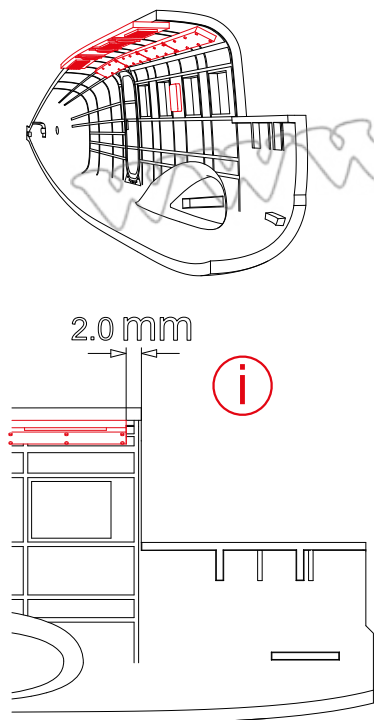

STEP 56b

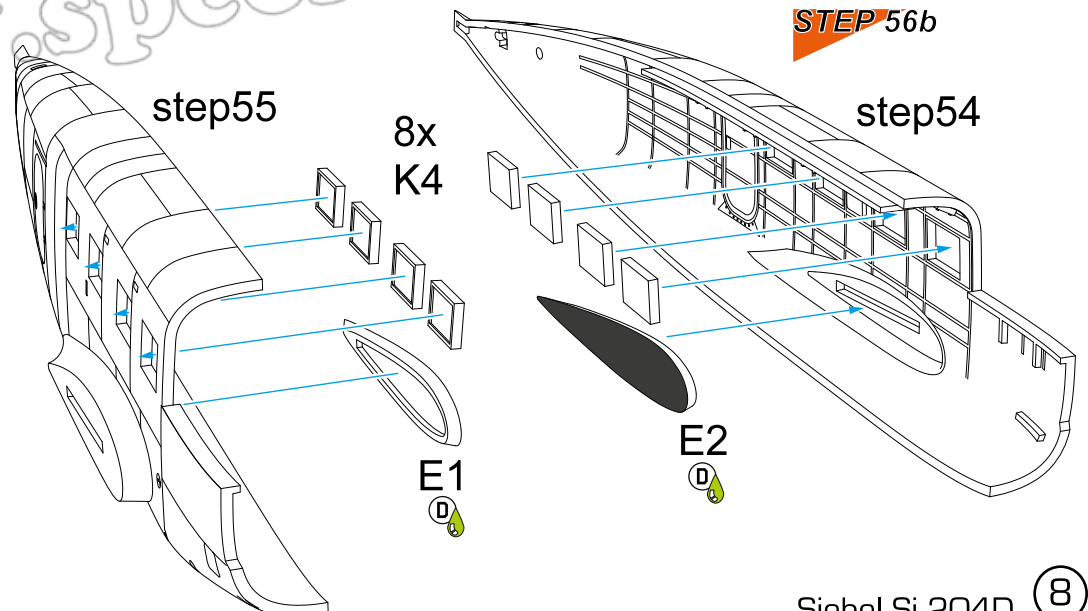

STEP 57

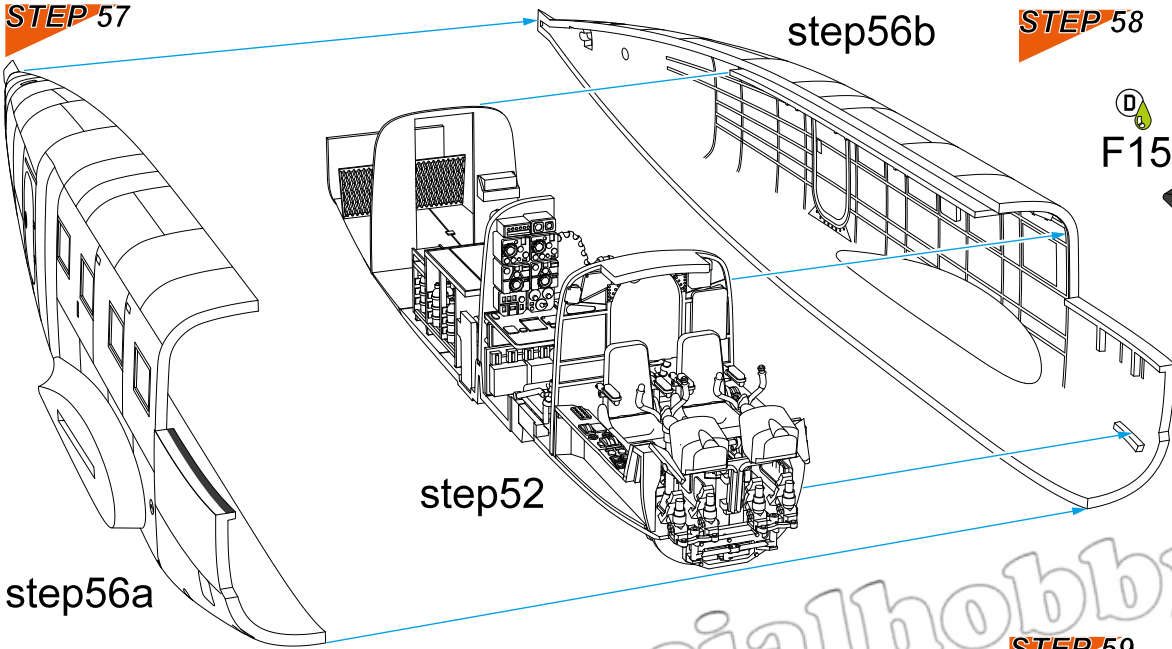

STEP 58

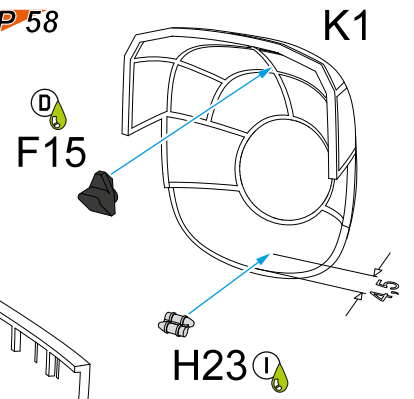

STEP 60

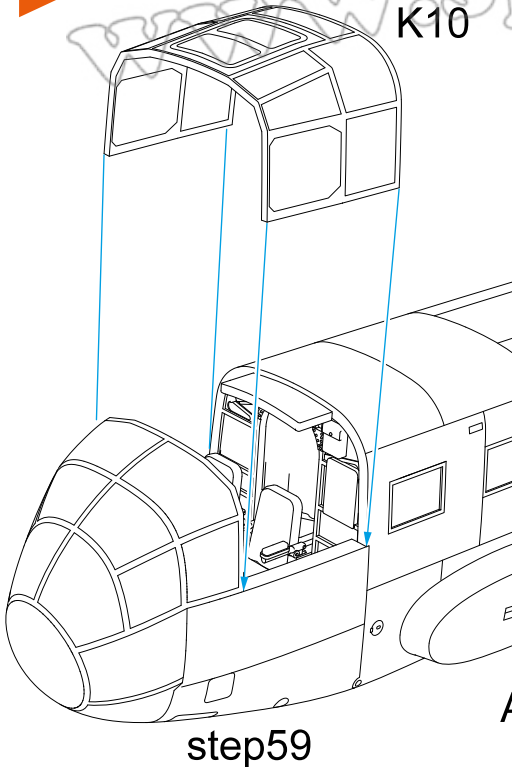

step58

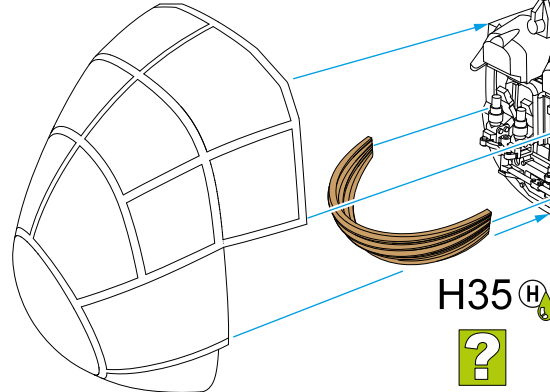

STEP 59

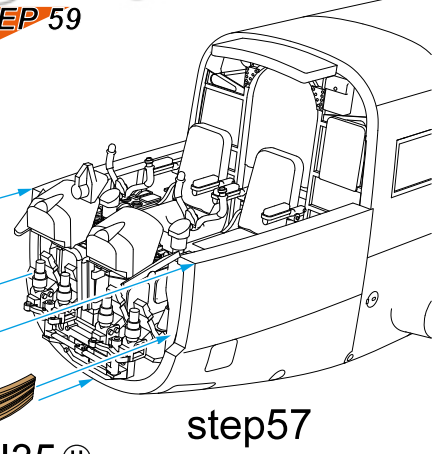

step59

step57

A7

A8

A7

A6

A5

step60

STEP 61

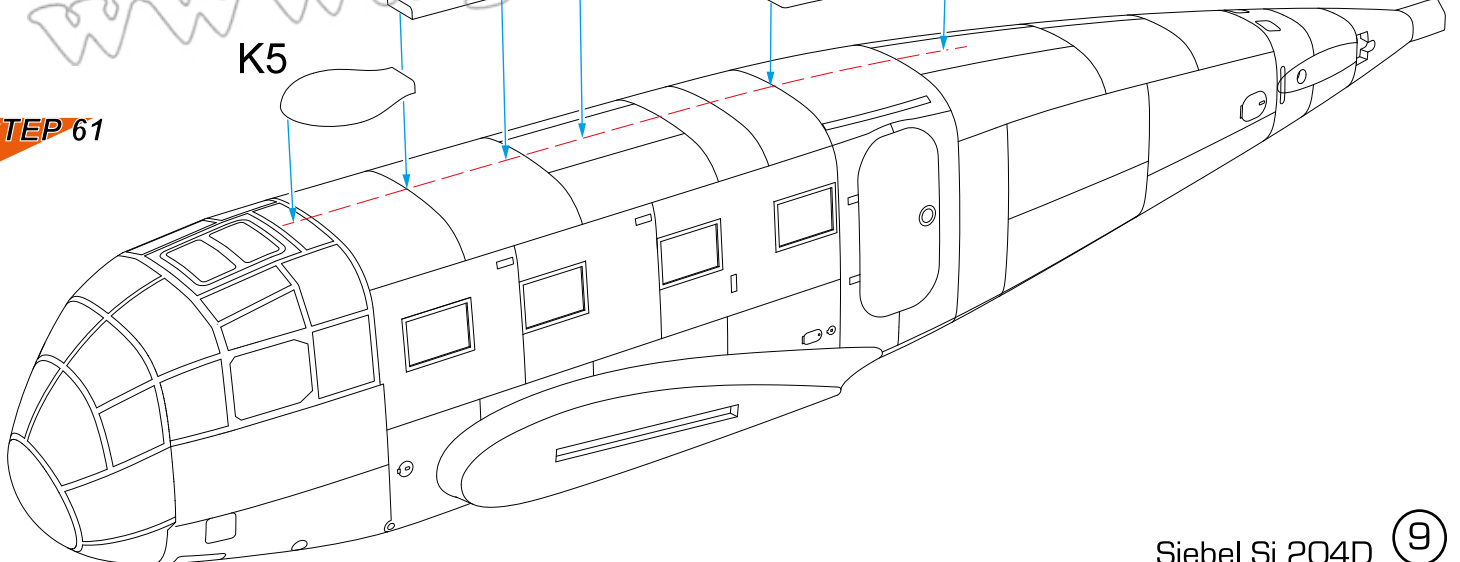

STEP 62

E C6/ B2 opposite

E26/ E25 opposite

Dry fit first

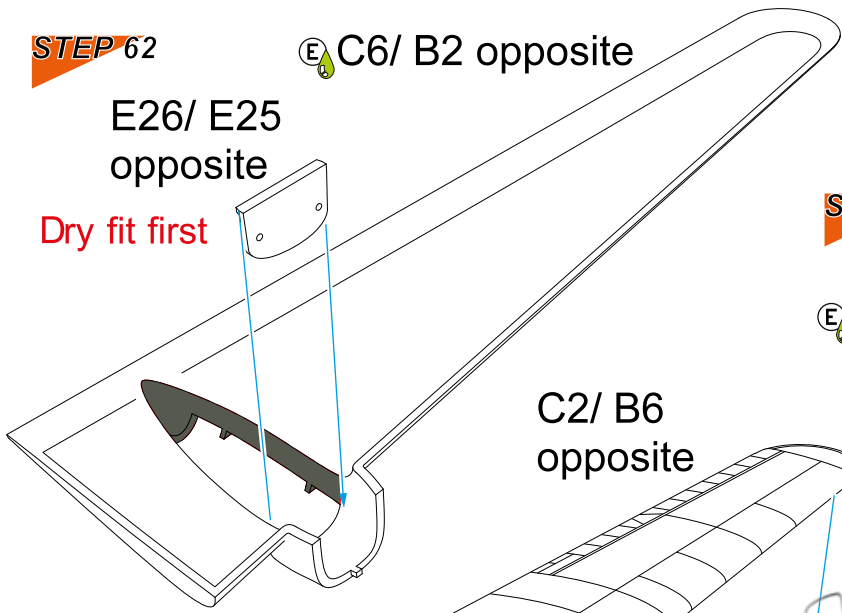

C2/ B6 opposite

STEP 63

E18/ E16 opposite

E1/ E2 opposite

E19/ E15 opposite

E E5/ E30 opposite

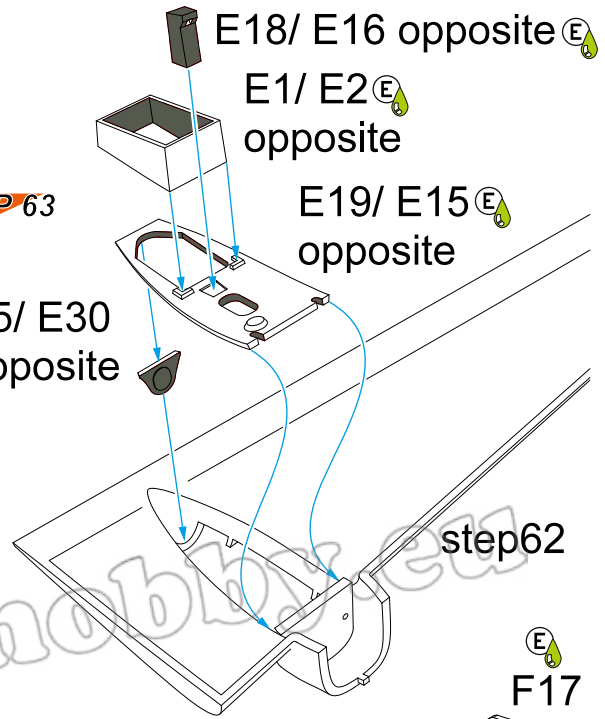

step62

E F17

STEP 64

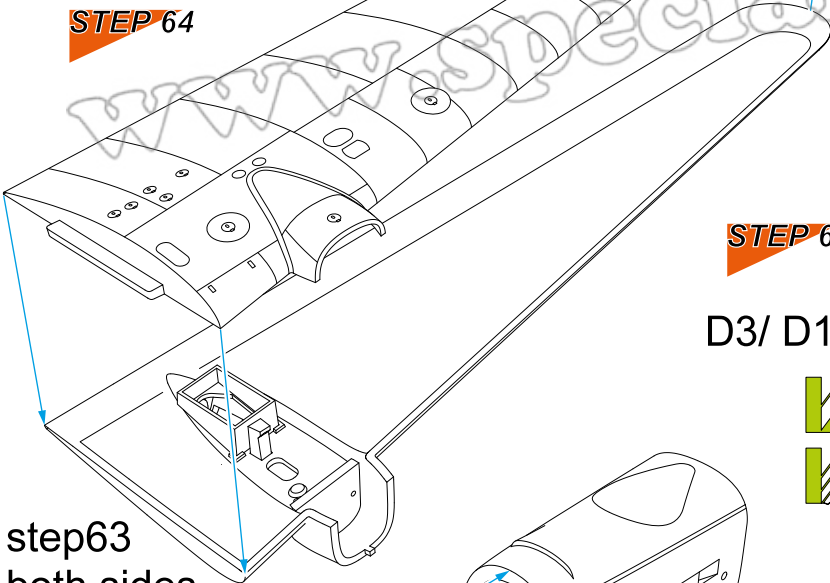

step63 both sides

STEP 67

D3/ D16

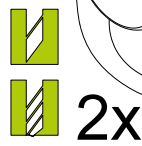

2x

STEP 65

F23/ F24

2x

F25/ F26

STEP 66

D8/ D11

D9/ D10

F D1/ D2

F D17/ D18

STEP 68

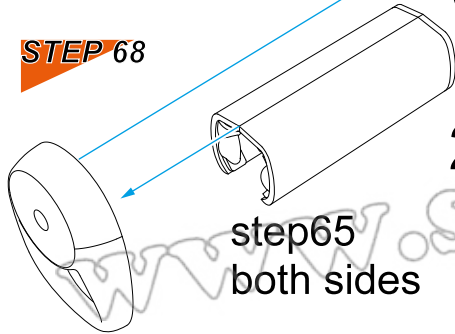

2x

step65 both sides

step66 both sides

step67 both sides

STEP 69

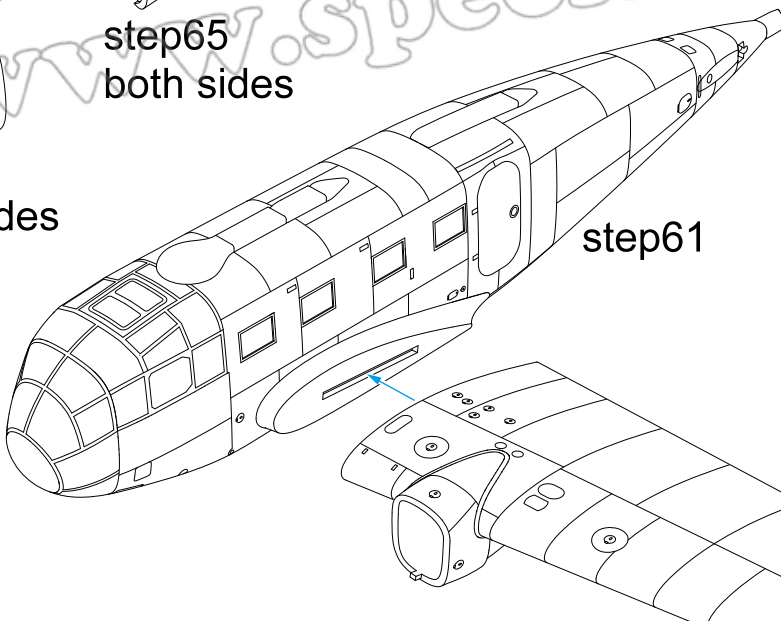

step61

step64 both sides

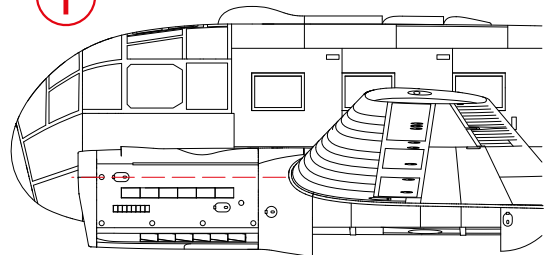

STEP 70

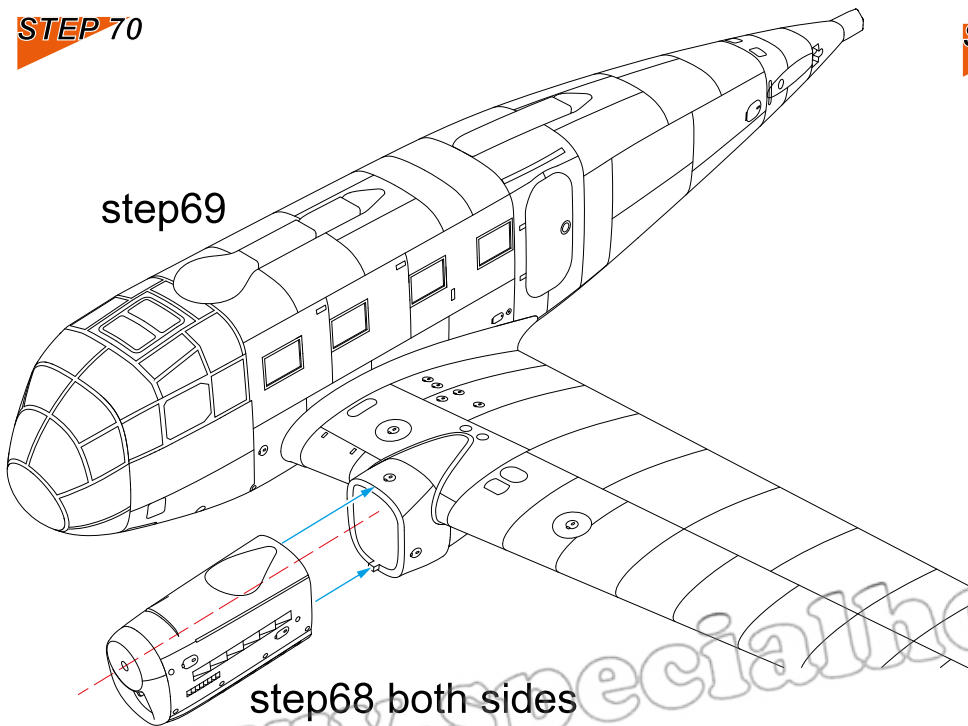

Dry fit first

STEP 71

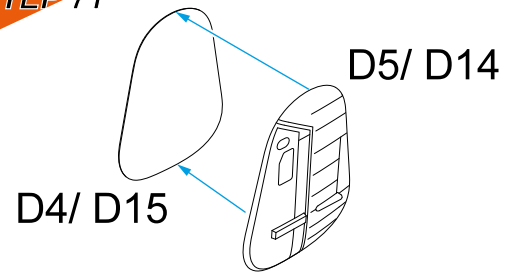

STEP 72

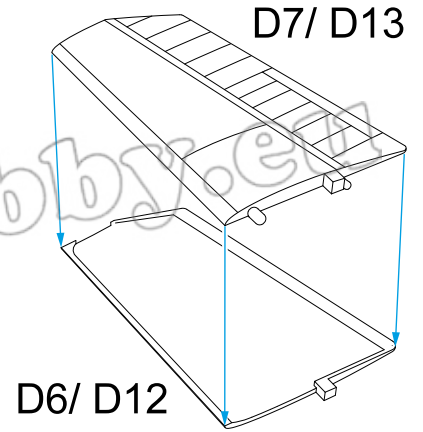

STEP 73

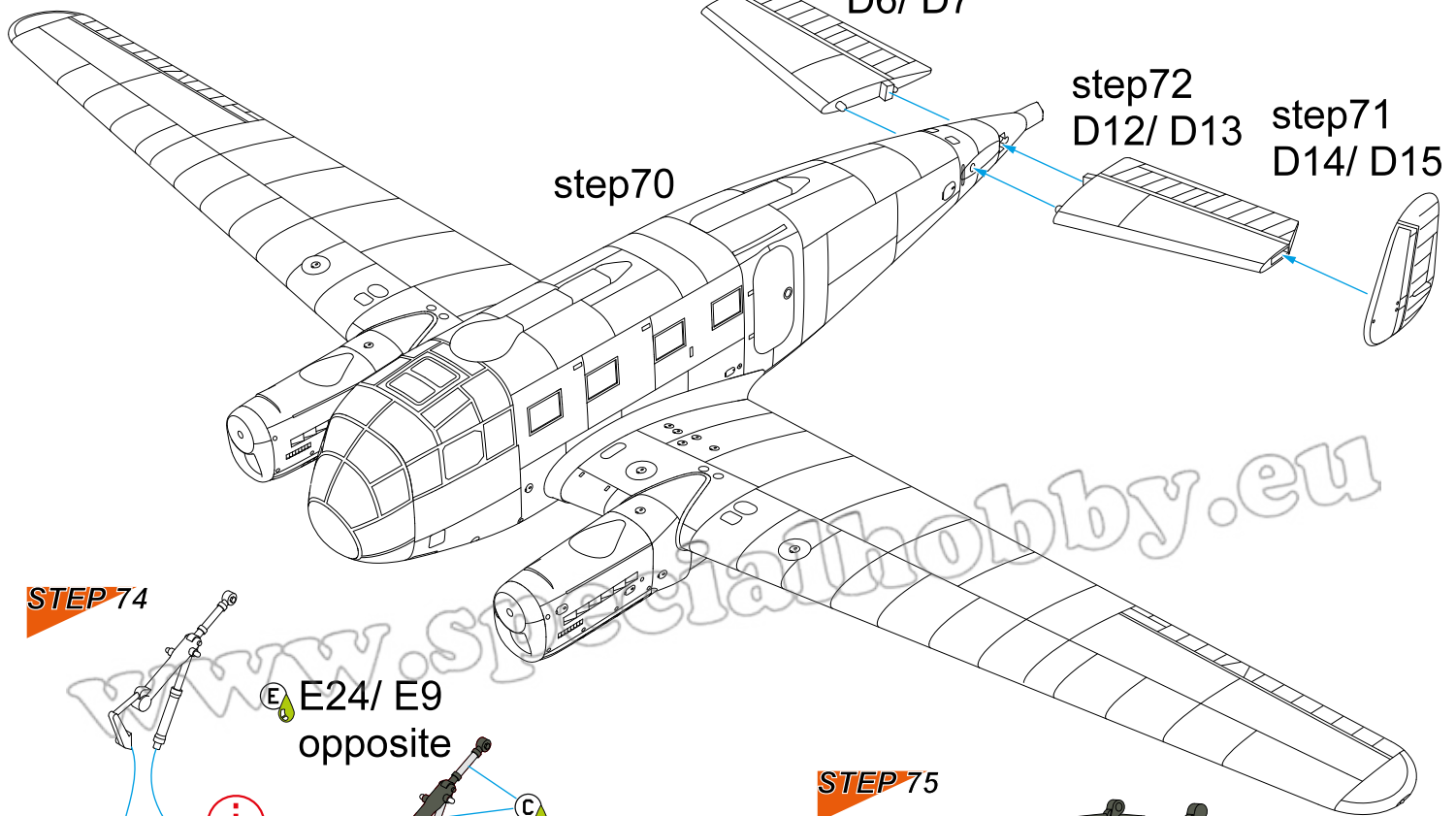

STEP 74

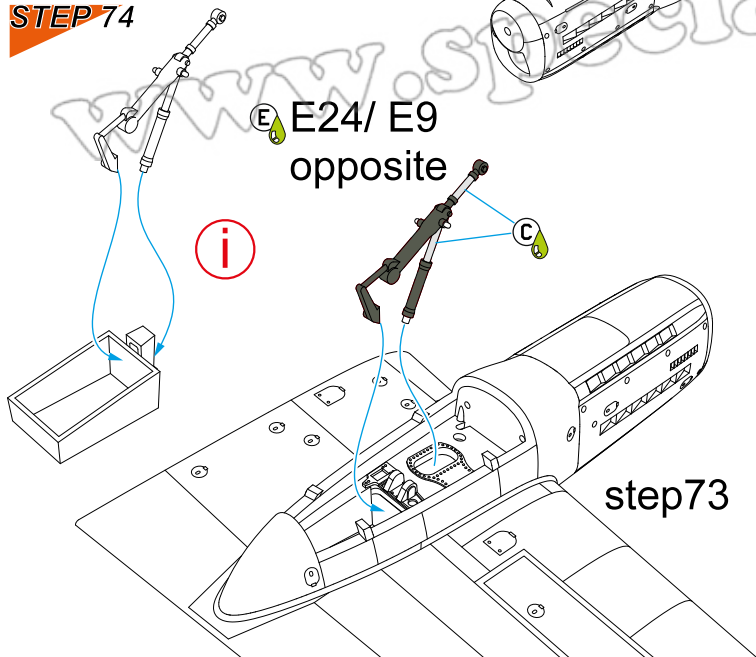

STEP 75

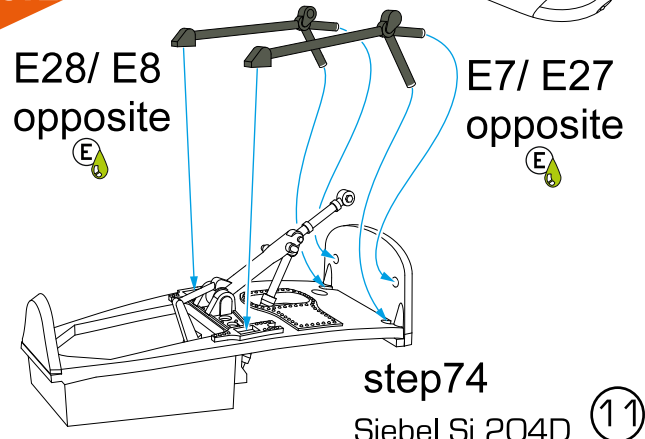

STEP 76

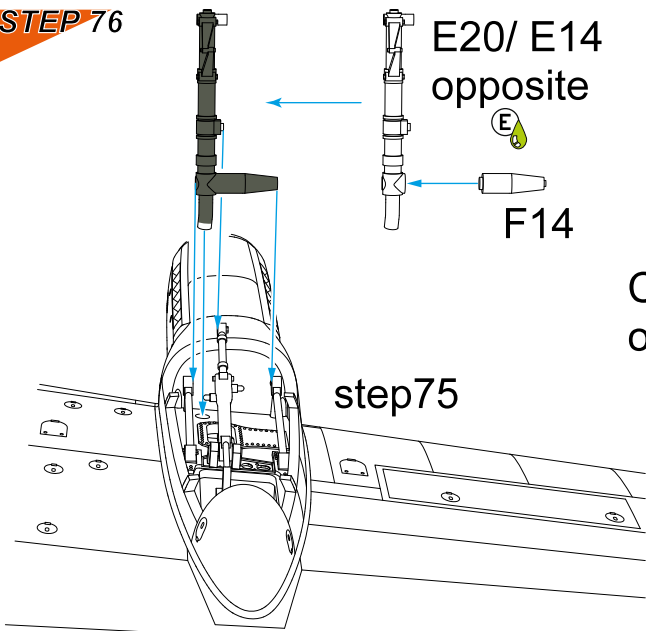

STEP 77

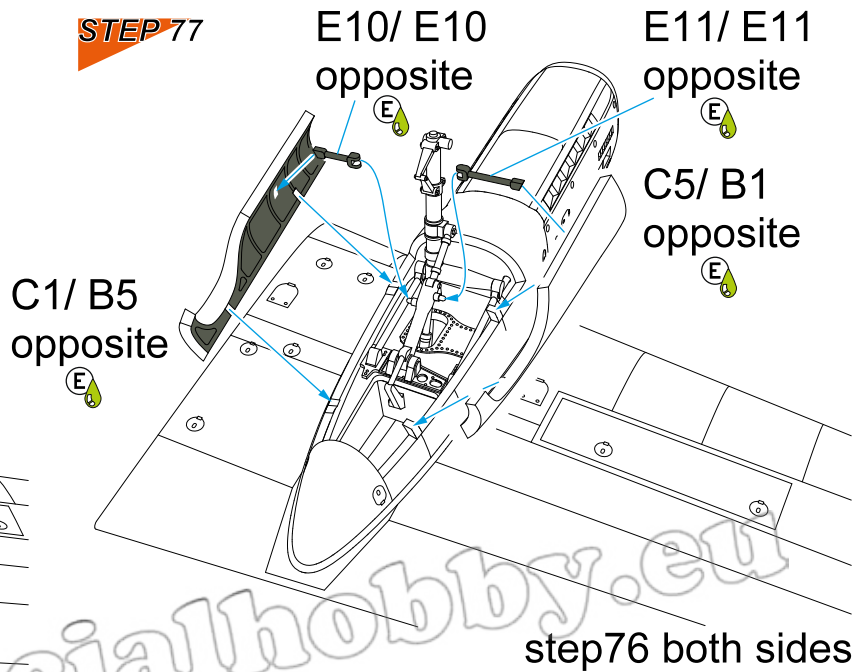

STEP 79

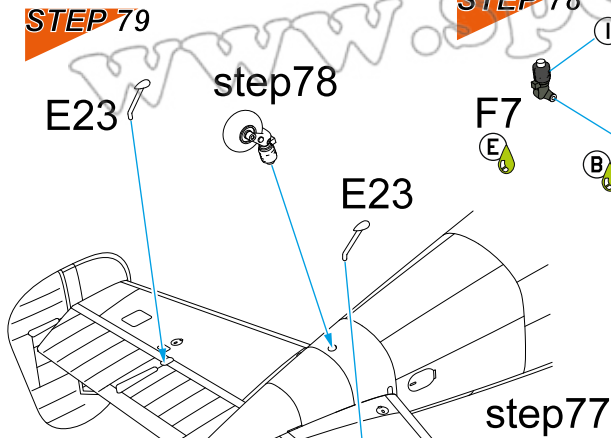

STEP 78

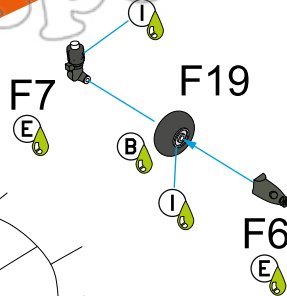

STEP 80

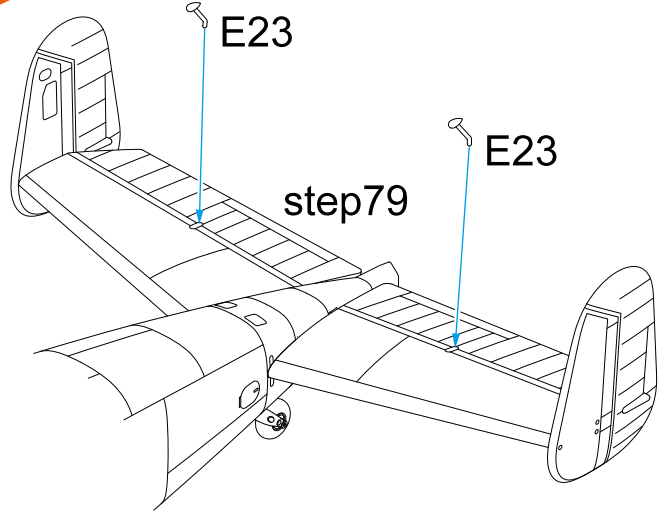

STEP 81

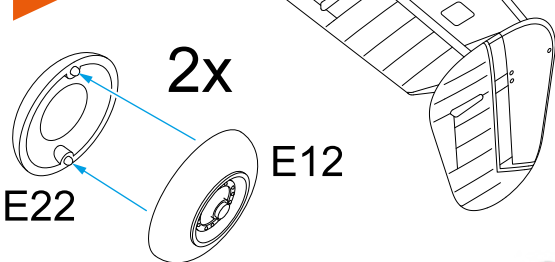

STEP 82

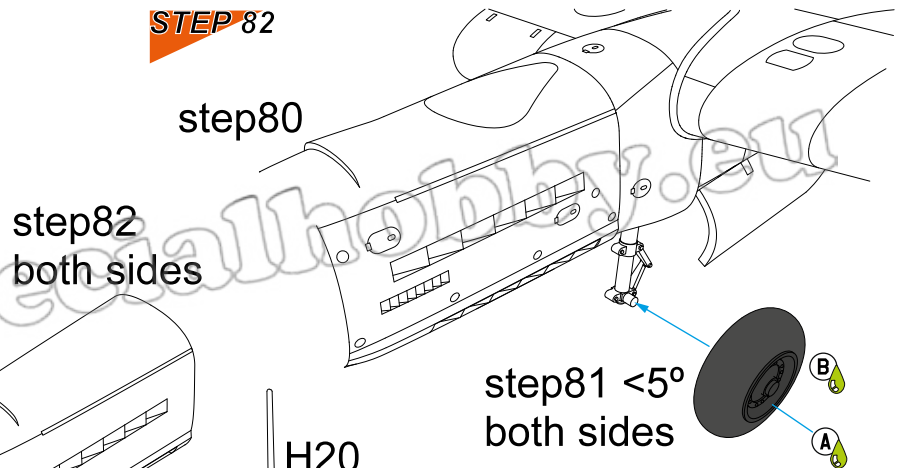

STEP 83

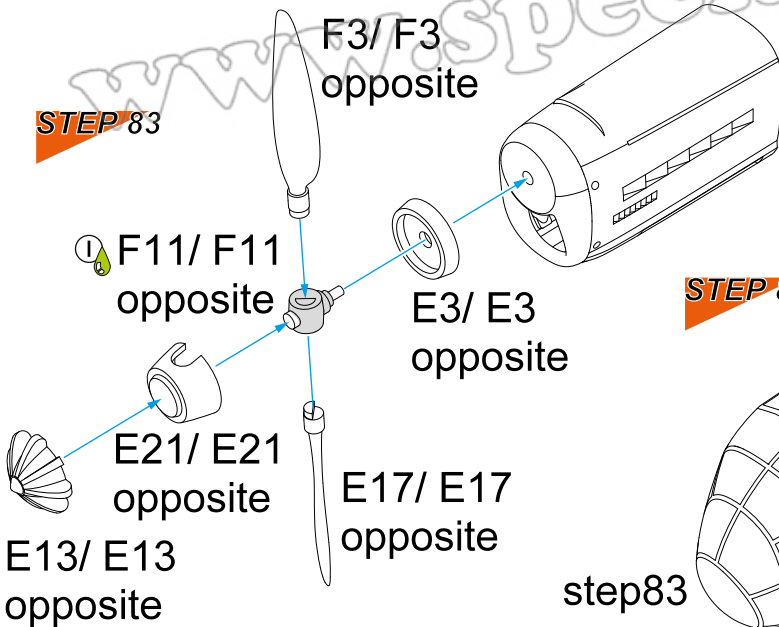

STEP 84

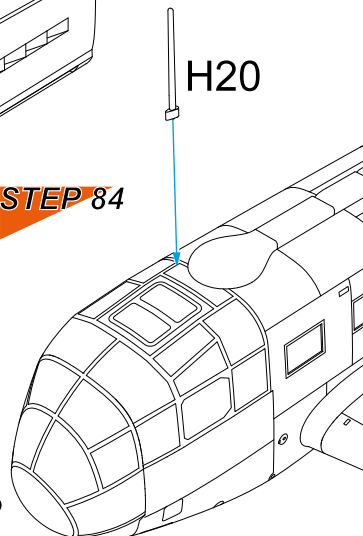

STEP 85

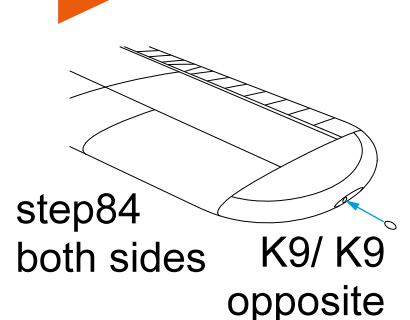

STEP 86

PUR1

camo C
only

step85

STEP 87

F13

step85/
step86 ?F16
<40°**STEP 89**

step87

STEP 88

F8

E6

? H45

D

K8

D

step88 ?

step87

F12

Barvy GUNZE/ GUNZE Colour No.

A Černá/ Black	H2/ C2	E Šedá 02/ Grey 02	H70/ C60	I Hliníková/ Aluminium	H8/ C8
B Barva pneu/ Tire Black	H77/ C137	F Opálený kov/ Burnt Iron	H76/ C61	J Mosaz/ Brass	MC219
C Tmavý kov/ Gun Metal	H28/ C78	G Barva kůže/ Leather	H17/ C29	K Barva dřeva/ Wood	H37/ C43
D Černošedá 66/ Black Grey 66	C116	H Pískově žlutá/ Sand Yellow	H66/ C119	L Červená/ Red	H3/ C3

SYMBOLSMOŽNOST VOLBY
OPTIONAL
NACH BELIEBEN
OPTIONPOUŽIT KYANOAKRYLÁTOVÉ LEPIDLO
INSTANT CYANOACRYLATE GLUE
ZYANOAKRYLATKLEBER
COLLE CYANOACRYLATOHNOUT
BEND
BIEGEN
COURBERZHOTOVIT NOVÉ
SCRATCH BUILD
FERTIGSTELLEN
ACHEVERŘEZAT/VRTAT
CUT OFF/DRILL
ENTFERNEN
DETACHER

GSI colour code

NATRÍT
COLOUR
FARBEN
PEINDRE

Siebel Si 204D-1, W.Nr. 221313, SR+AU, Flugzeugführerschule (FFS) C15, Luftwaffe, based at Bourges, occupied France, Summer 1943. This aircraft had a yellow fuselage band and a couple of its cockpit glazing panes was painted white.

Siebel Si 204D-1, W. Nr. 221313, SR+AU, Flugzeugführerschule (FFS) C15, Luftwaffe, základna Bourges, okupovaná Francie, léto 1943. Letoun, označený žlutým pruhem na trupu měl část prosklení předě trupu zatřené bílou barvou.

CAM. A

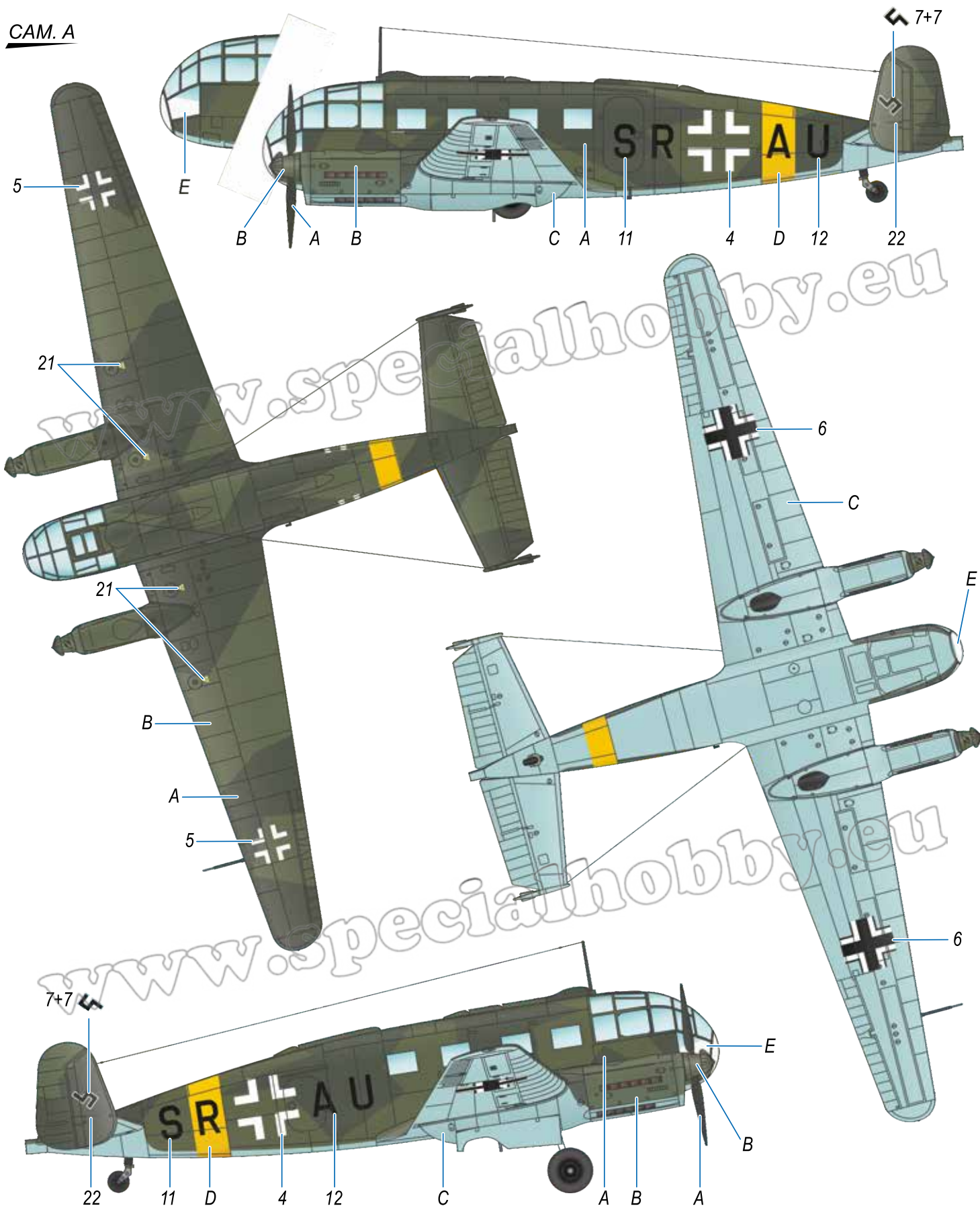

- | | | | | |
|---|--|---|---|---|
| A Black Green
Schwarzgrün
Černozelená
H65/C18/RLM70 | B Dark Green
Dunkelgrün
Tmavě zelená
H64/C17/RLM71 | C Light Blue
Hellblau
Světle modrá
H67/C115/RLM65 | D Yellow
Gelb
Žlutá
H413/C113/RLM04 | E White
Weiß
Bílá
H1/C1 |
|---|--|---|---|---|



Siebel Si 204D, DL+NT, Luftwaffe, 1945. On 7 May 1945 it landed at Belpu in the Swiss Confederation with its national markings painted out and the colour still sticky. Five people arrived aboard the plane including Grand Mufti of Jerusalem Mohammed Amin al-Husseini. War criminal al-Husseini was sent back and the aircraft seized by the Swiss military.

Siebel Si 204D, DL+NT, Luftwaffe, 1945. Tento letoun přistál 7. 5. 1945 v Belpu ve Švýcarsku. V té době měl zatřené výsostné znaky (po přistání byla barva ještě čerstvá). Na palubě bylo pět osob, včetně Amína al-Husajního, velkého jeruzalémského muftího. Válečný zločinec Amín al-Husajní byl vrácen do Německa a letoun byl zabaven švýcarským letectvem.

CAM. B

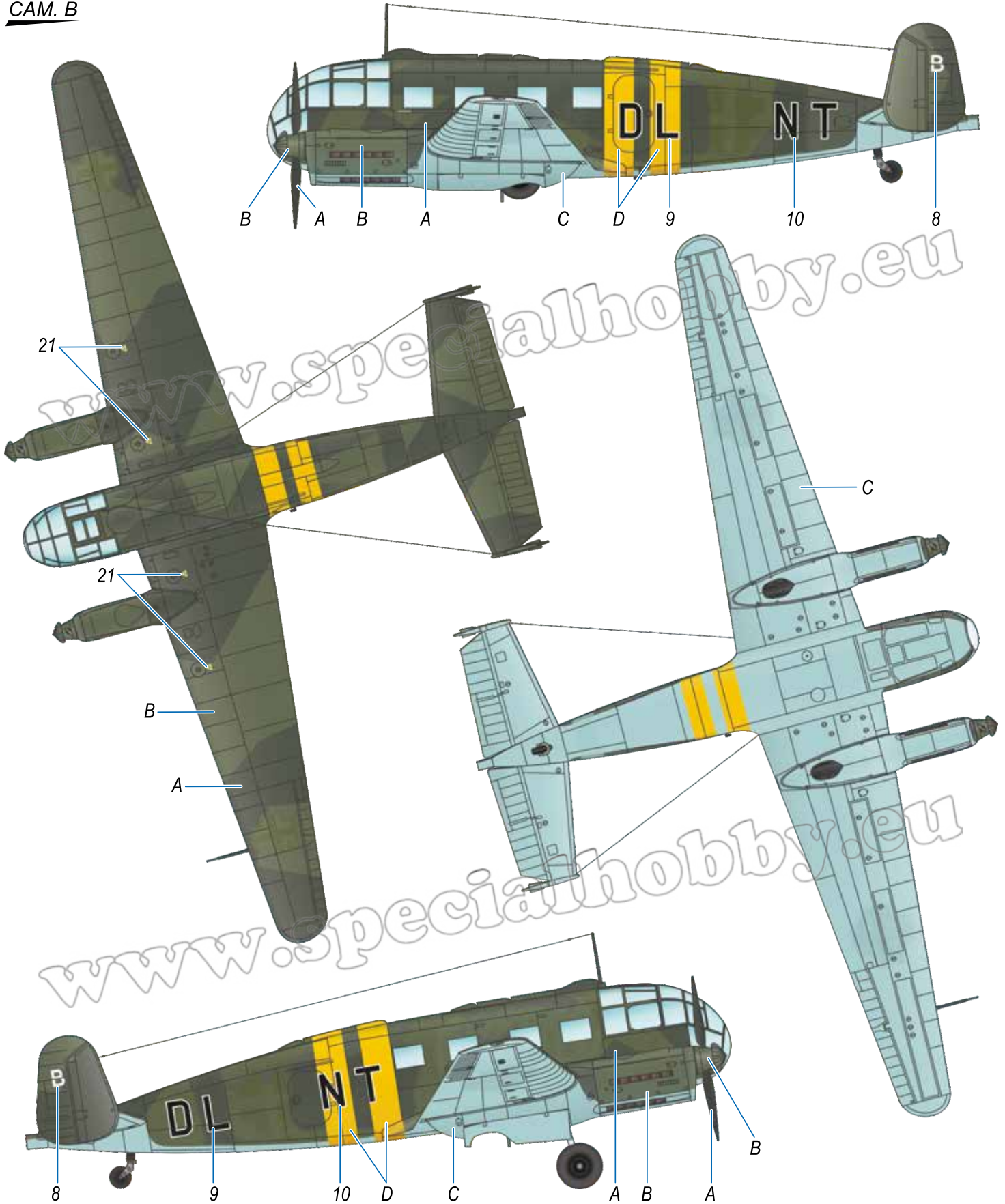

- | | | | | | | | |
|----------|--|----------|---|----------|--|----------|--|
| A | Black Green
Schwarzgrün
Černozelená
H65/C18/RLM70 | B | Dark Green
Dunkelgrün
Tmavě zelená
H64/C17/RLM71 | C | Light Blue
Hellblau
Světle modrá
H67/C115/RLM65 | D | Yellow
Gelb
Žlutá
H413/C113/RLM04 |
|----------|--|----------|---|----------|--|----------|--|



Siebel Si 204D, B-3 (ex DL+NT), Swiss Air Force, Dübendorf, Switzerland, 1945–1955.

Siebel Si 204D, B-3 (ex DL+NT), Schweizer Luftwaffe, Dübendorf, Švýcarsko, 1945–1955.

CAM. C

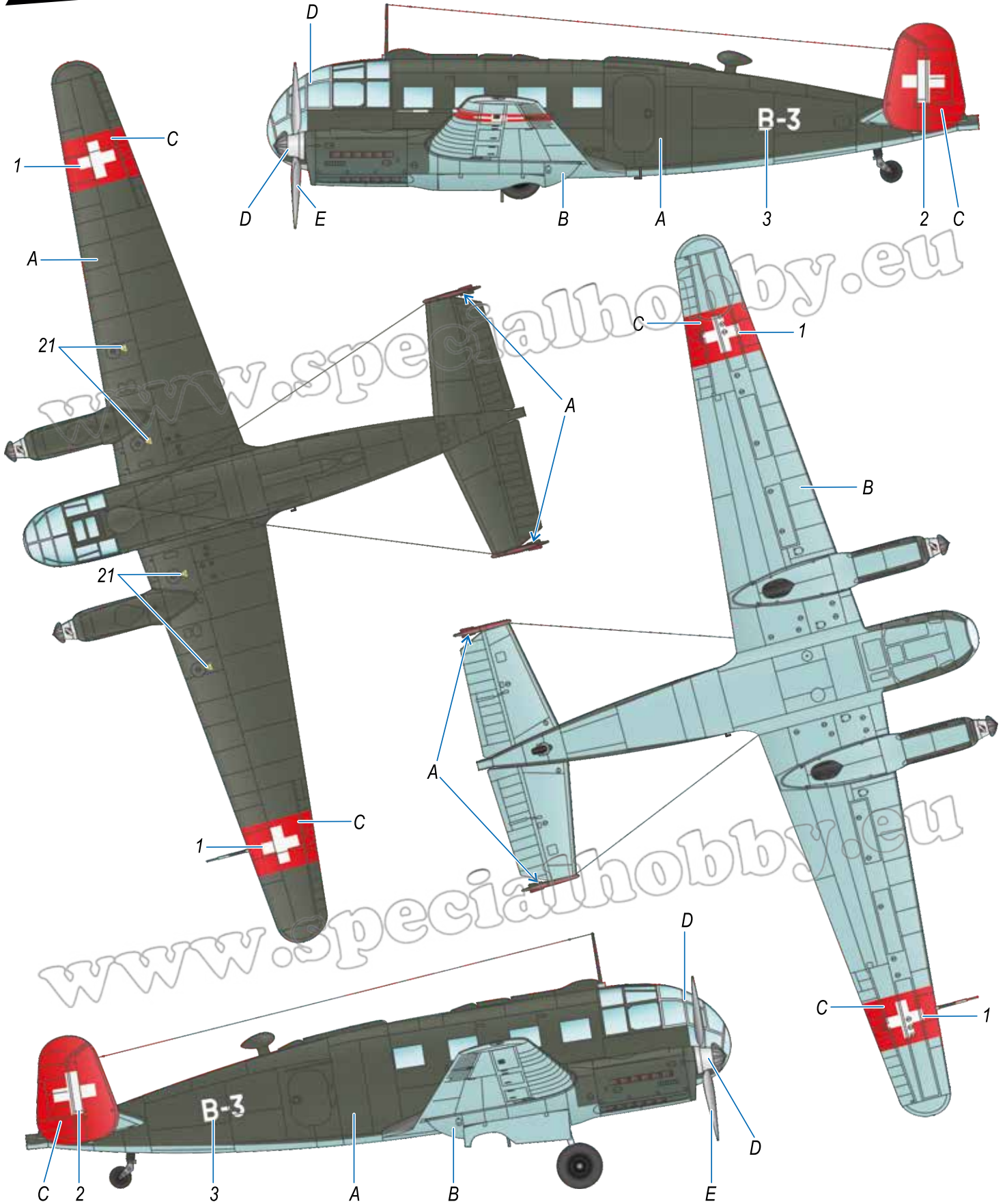

A	Black Green Dunkelgrün Černozelená H65/C18/RLM70	B	Light Blue Graublau Světle modrá H67/C115/RLM65	C	Red Rot Červená H3/C3	D	Aluminium Hliníková H8/C8	E	Steel Ocelová H18/C28
----------	---	----------	--	----------	--------------------------------	----------	---------------------------------	----------	-----------------------------

Swiss 'Dunkelgrün' and 'Graublau' were licence produced 'Schwarzgrün' and 'Hellblau' German camouflage shades.

