

Driver: Michal Orlowski Date: 8th October 2023 Event/Track: Workshop  
Qualify: 1st Final: 1st Best Lap: 17.9

**TRACK TYPE**

Grip Level High  Medium  Low   
 Type Tight  Open  Mixed   
 Condition Flat  Bumpy  Mixed   
 Surface Clay  Long Astro  Carpet   
 Grass  Short Astro  Mixed   
 Weather cork floor

**TYRES**

|         | FRONT      | REAR       |
|---------|------------|------------|
| Tyres   | Honeycomb  | Honeycomb  |
| Wheels  | Schumacher | Schumacher |
| Inserts | Cragg      | Cragg      |

Notes:

Notes:

**FRONT SUSPENSION**

KEY: P = Plastic, A = Alloy, B = Brass, CF = Carbon Fibre, S2 = Schumacher Composite, M = Medium, S = Stiff, Sh = Short, H = High, L = Low, F = Front, R = Rear, Y = Yes, N = No

Ride Height 18 mm  
 Wheelbase 0  +1.5  +3.0  +4.5   
 Toe 1 deg In  Out   
 Camber at Ride Height -1.5 deg  
 Anti Roll Bar 0.9  1.0  1.1  1.2   
 Front Wing Y  N   
 Bump Steer Washers 1 mm  
 Pivot Block Height H  M  L   
 Steering Arm Kit  A  B  C

Notes:

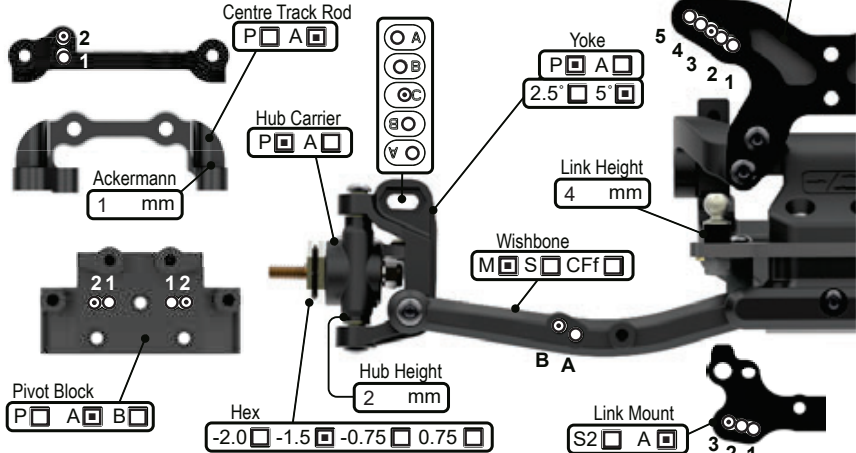

**REAR SUSPENSION**

KEY: P = Plastic, A = Alloy, B = Brass, CF = Carbon Fibre, S2 = Schumacher Composite, M = Medium, S = Stiff, Sh = Short, H = High, L = Low, F = Front, R = Rear, Y = Yes, N = No

Ride Height 18 mm  
 Wheelbase 0  +2  +4  +6   
 Anti-Squat 1  2  3  4   
 Toe 4  3.5  3  2.5  2  1.5  1.0  0.5   
 Camber at Ride Height -1.5 deg  
 Anti Roll Bar 1.0  1.1  1.2  1.3  1.4   
 Wing Gurney Height mm  
 Rearward Shock Position Y  N   
 Driveshaft Type CVD  U/J   
 Gearbox Type Laydown  Layback

Notes:

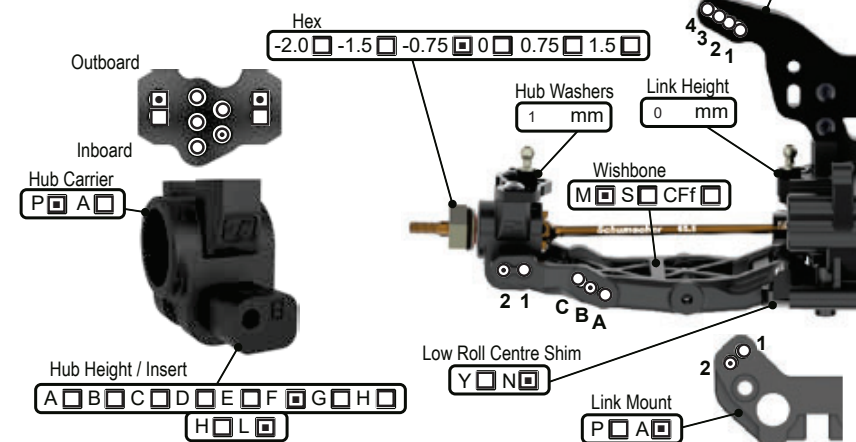

**TRANSMISSION**

B = Ball, 2g = 2 Gear, 4g = 4 Gear  
 Diff Height H  M  L   
 Diff Oil cSt  
 Diff Type B  2g  4g   
 Motor 7t  
 Rotor Dia. 12.5 mm  
 Timing 35 deg  
 Pinion 21 t  
 Spur 78 t  
 Motor Plate A  CF   
 Lock Out Y  N   
 Slipper Plates 2  3

**CHASSIS**

Chassis A  C/F   
 Chassis Insert 0mm  +5mm   
 LiPo Position 1  2  3  4  5  6  7  8   
 X Brace Y  N   
 Running Weight 1480 g  
 Radio Tray 1  2  3   
 Notes:  
 No weight at the front of the car

**EQUIPMENT**

E.S.C. HW G2S  
 Servo PowerHD GTS-3  
 RX Sanwa RX-493i  
 LiPo Sunpadow 3800  
 Bodyshell JC F2

**WEIGHTS**

Chassis F  R   
 Rear Strap F  R   
 Radio Tray Y  N   
 Under LiPo Y  N

**SHOCKS**

KEY: i = Internal, e = External, V = Vented, S = Sealed, A = Aeration

|              | FRONT  | REAR   |
|--------------|--|--|
| Cap          | V <input type="checkbox"/> S <input type="checkbox"/> A <input type="checkbox"/> | V <input type="checkbox"/> S <input type="checkbox"/> A <input type="checkbox"/> |
| Body         | kashima  | kashima  |
| Oil          | 450 cSt  | 400 cSt  |
| Piston       | 3x1.6  | 3x1.7  |
| Spring       | blue hr lb/in  | blue hr lb/in  |
| Limiters (i) | mm   | mm   |
| Stroke       | 22.5 mm  | 29.0 mm  |
| Limiters (e) | mm   | mm   |

Notes:

