

# Bulldog T.1



## TARANGUS

TA4806

The Bulldog, initially developed by Beagle Aircraft, as the B.125 Bulldog, first flew on May 19, 1969. The first order for the type came from the Swedish Air Force. However, before any planes were actually built, Beagle Aircraft ceased trading and the production rights, along with the Swedish order, were transferred to Scottish Aviation.

The airplane was operated by the United Kingdom (130 a/c for the RAF, five of which were later transferred to the armed forces of Malta), Sweden (58 a/c for the air force, 20 for the army), Malaysia (15), Kenya (14), Ghana (13), Nigeria (37), Jordan (22), Lebanon (6), Hong Kong (2), Botswana (6) and one for a civilian customer in Venezuela.

Today, many Bulldogs have found a new life with civilian operators, as both the RAF and the Swedish air force have sold off their aircraft.

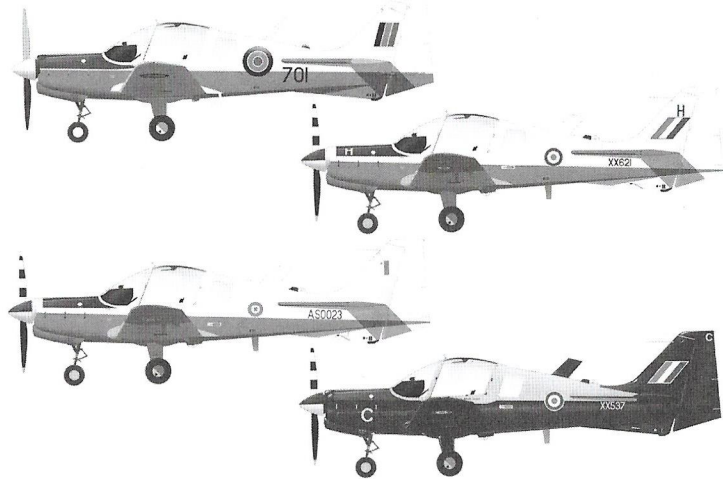

Scale 1/48

# Bulldog T.1

Scale 1/48

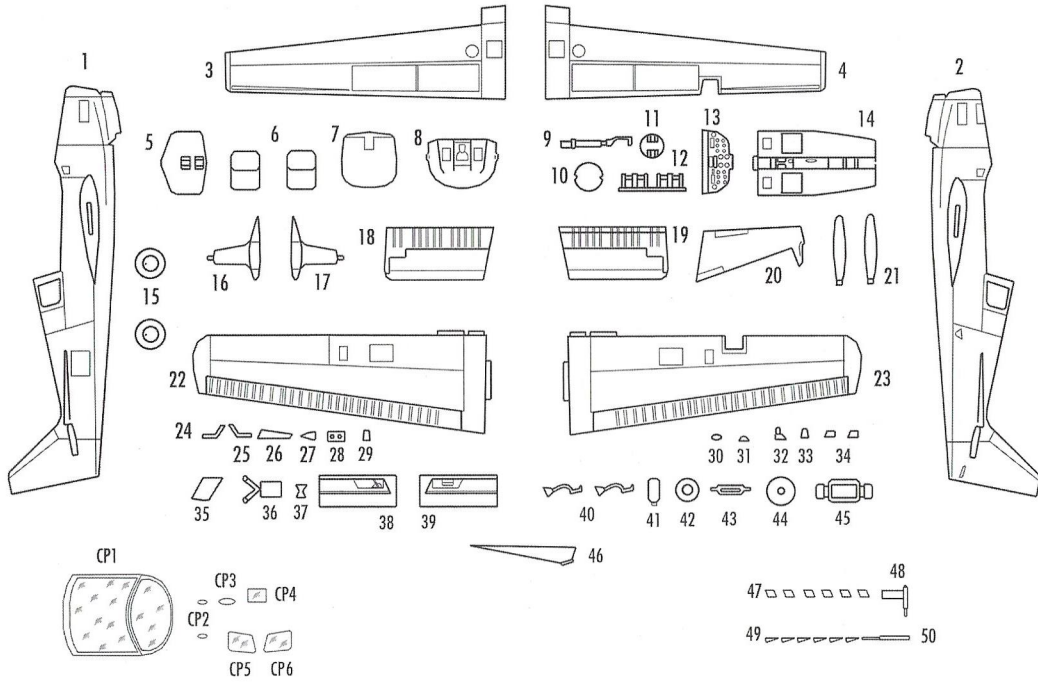

- |            |         |          |         |        |        |
|------------|---------|----------|---------|--------|--------|
|            |         |          |         |        |        |
| Matt Black | Lt.Grey | Dk.Green | Leather | Chrome | Silver |
|            |         |          |         |        |        |
| Aluminium  | Rust    | Tyre     | Red     | Green  | Yellow |

- |                     |           |        |      |         |               |                      |   |
|---------------------|-----------|--------|------|---------|---------------|----------------------|---|
|                     |           |        |      |         |               |                      |   |
| Cross-hatch pattern | Open hole | Remove | Band | Antenna | Scratch build | Symmetrical assembly | ? |

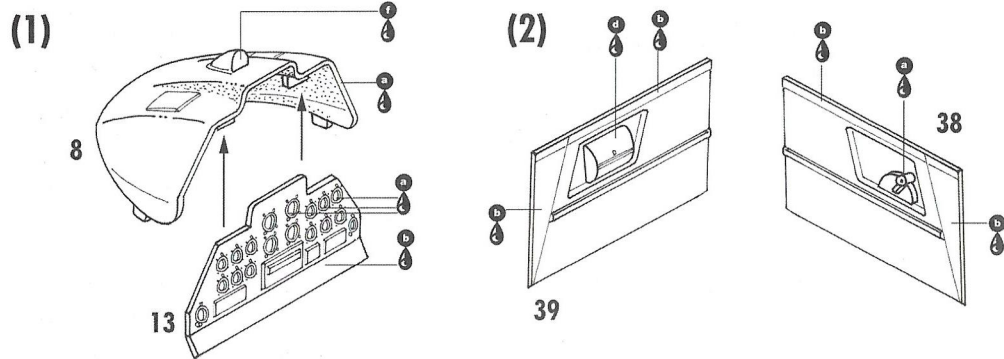

# Bulldog T.1

Scale 1/48

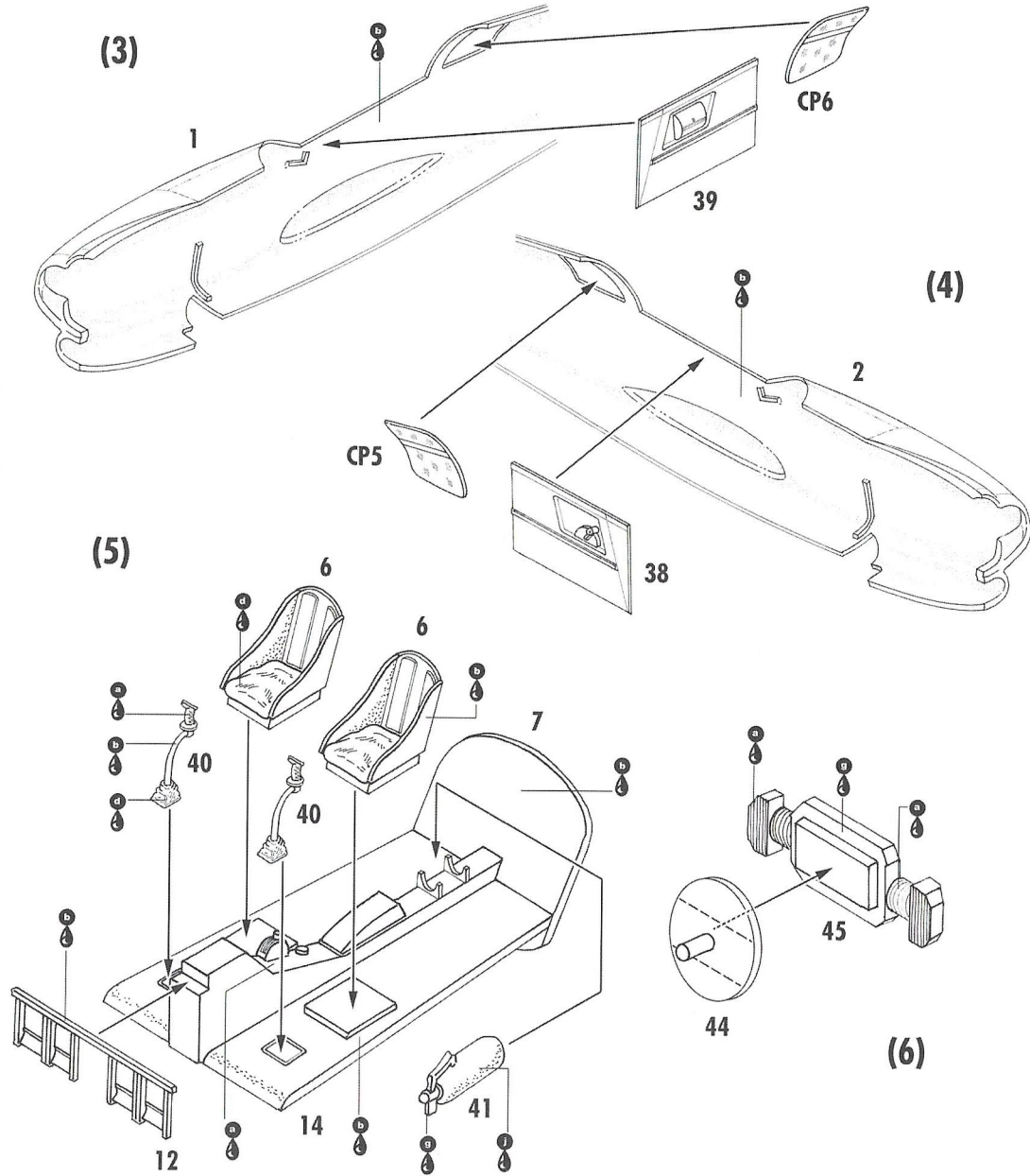



(7)

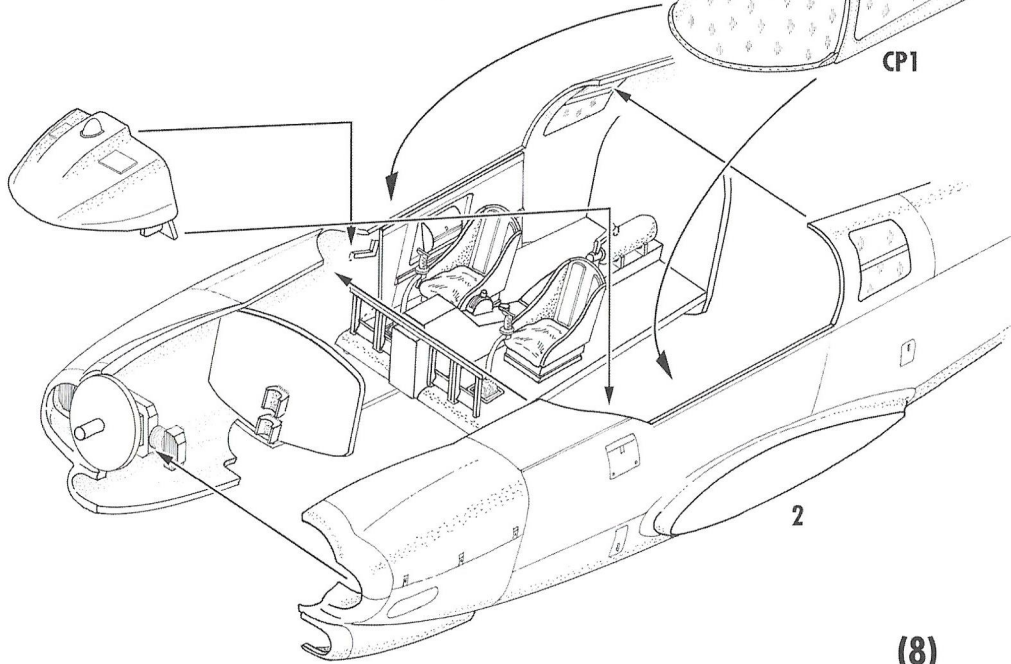
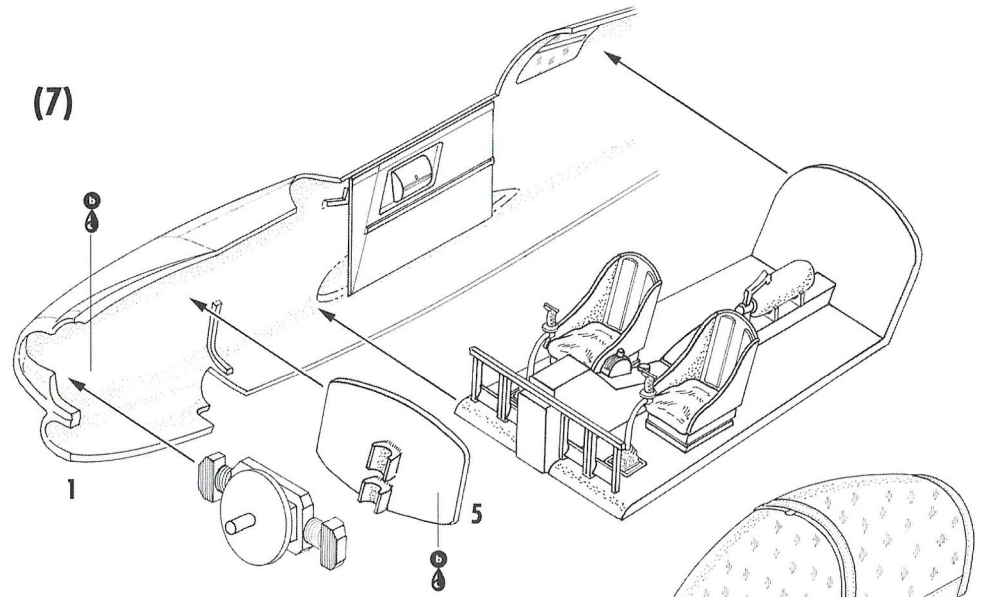

(8)

(9)

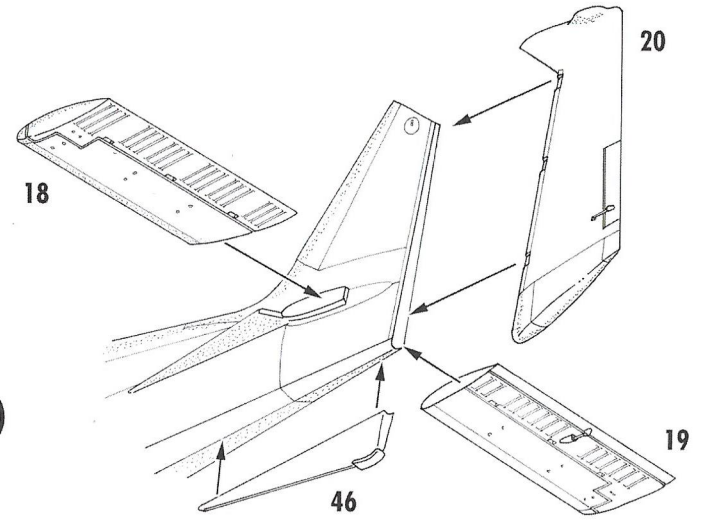

(10)

(info)

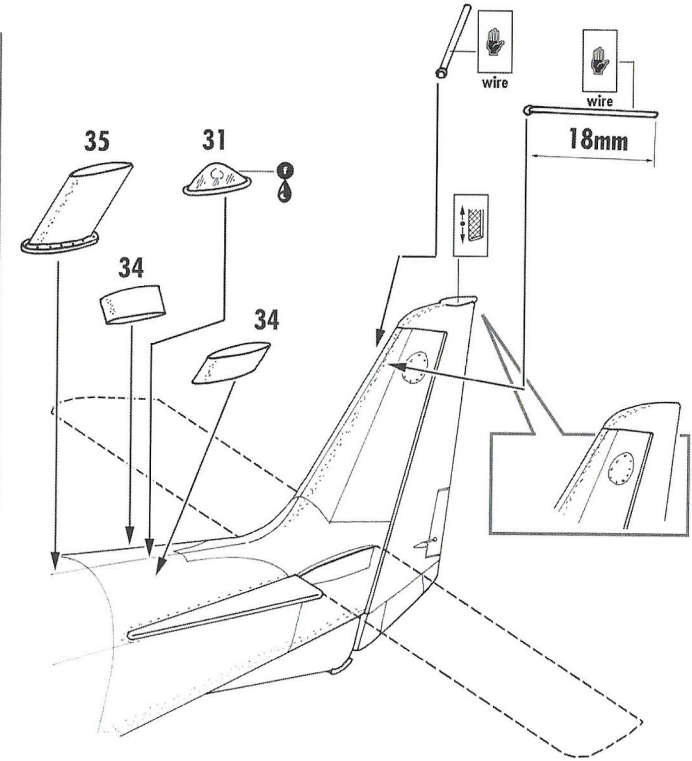
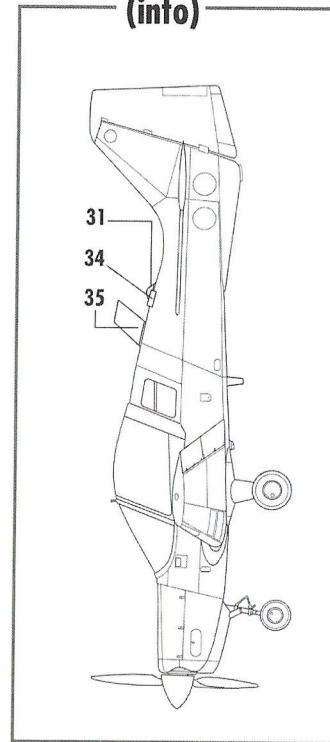

(11)

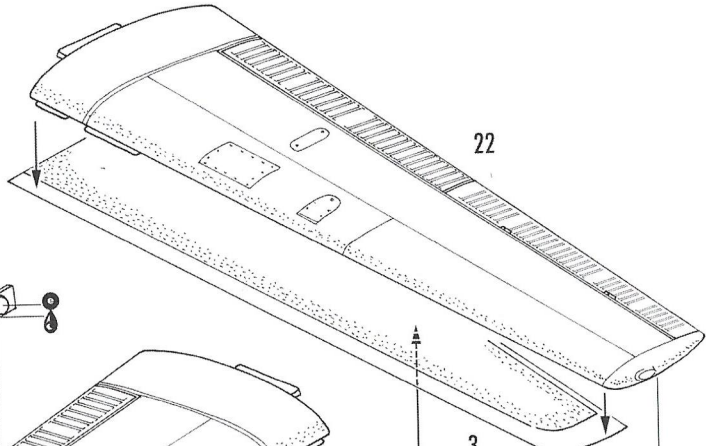

(12)

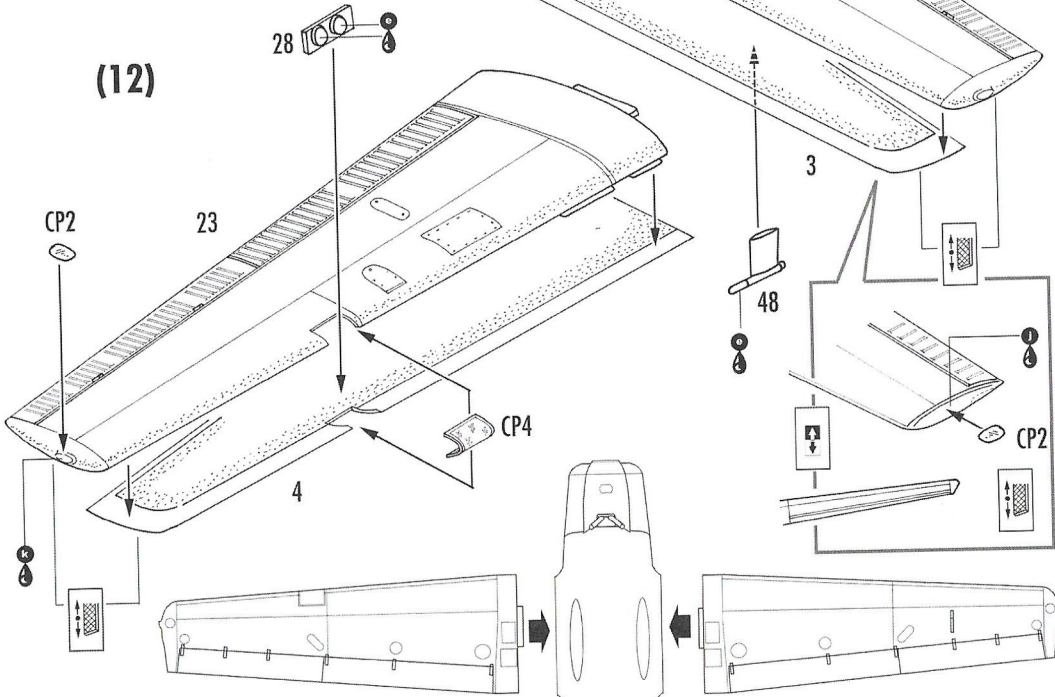

(13)

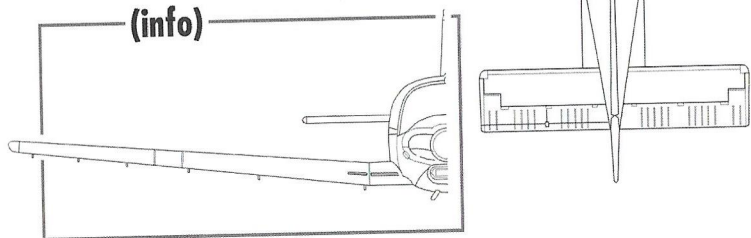

(14)

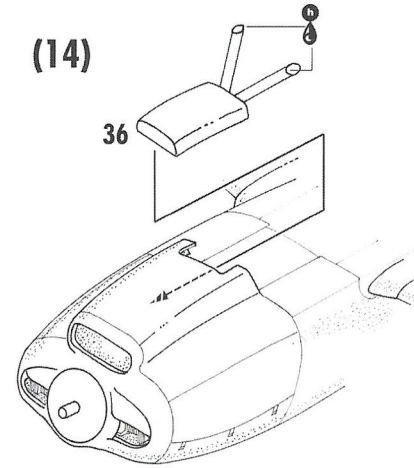

(15)

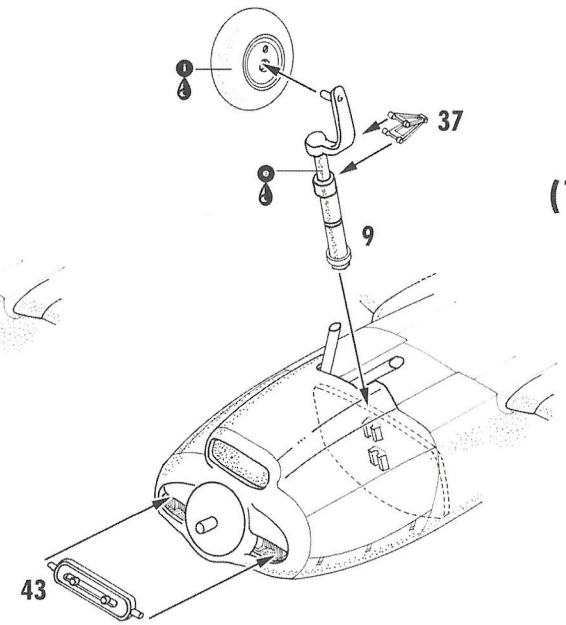

(16)

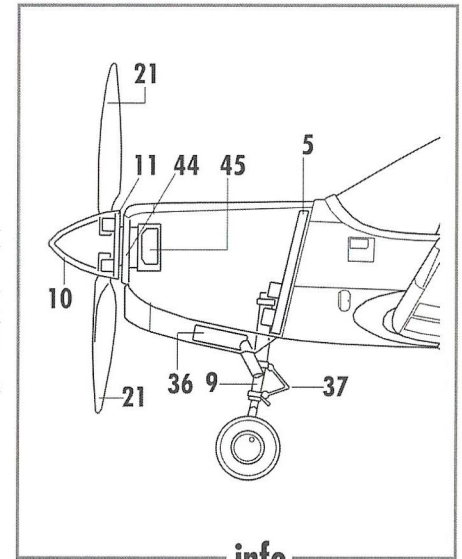
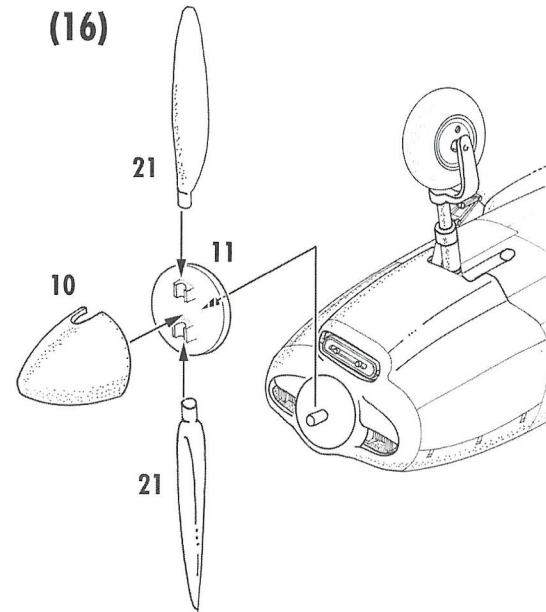

info



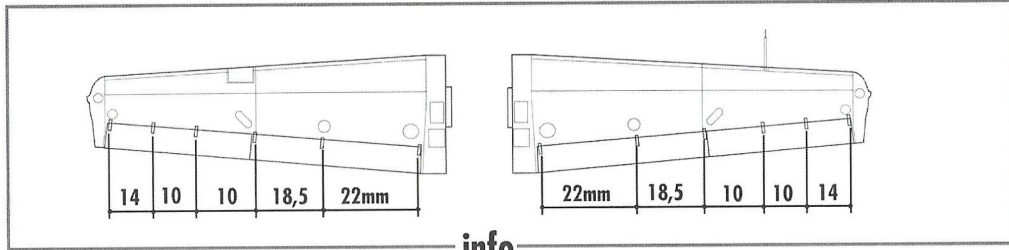

(17)

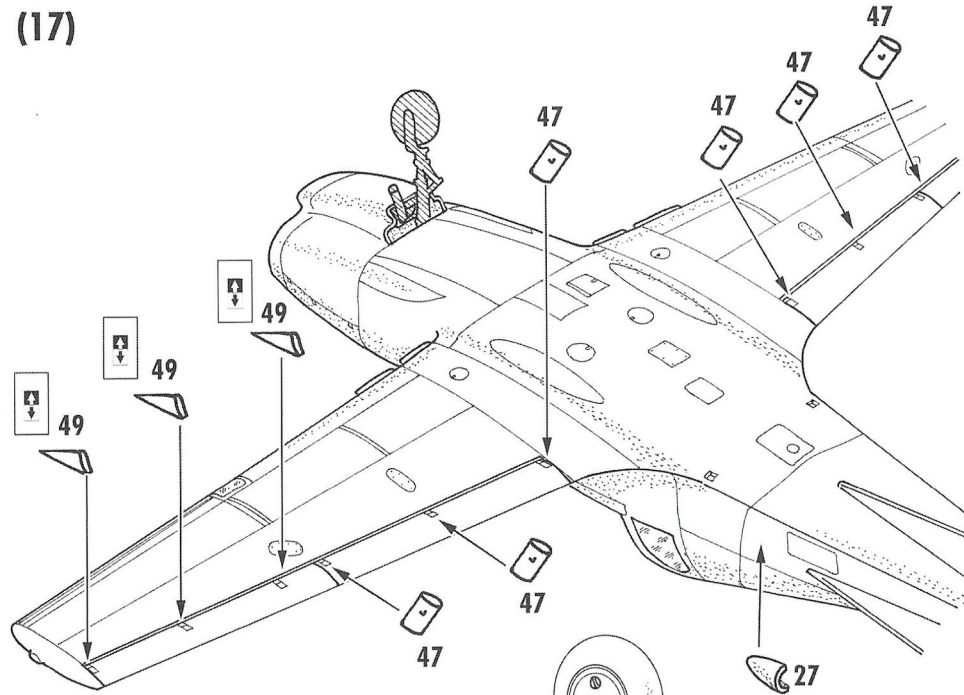

(18)

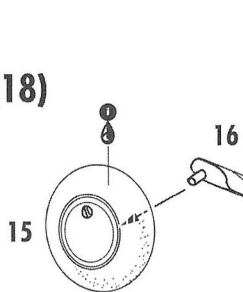

16

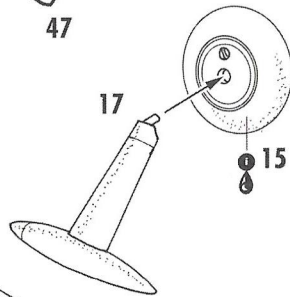

(19)

(20)

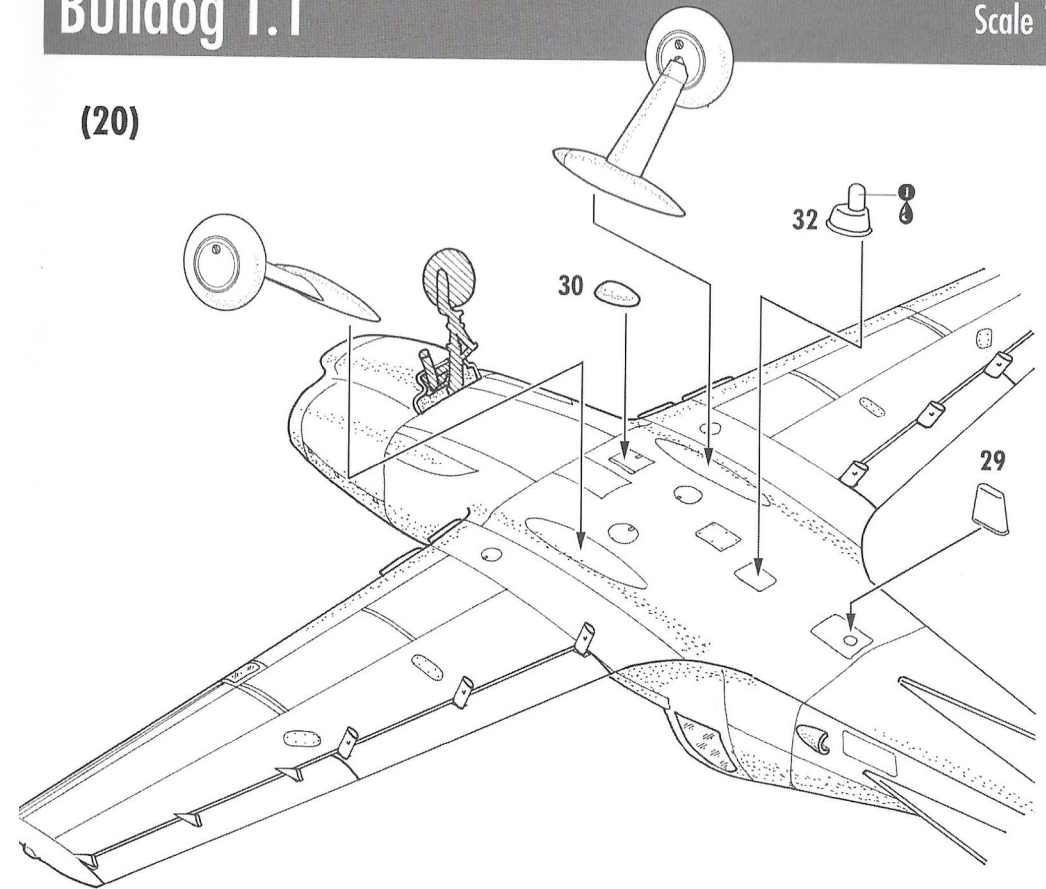

info

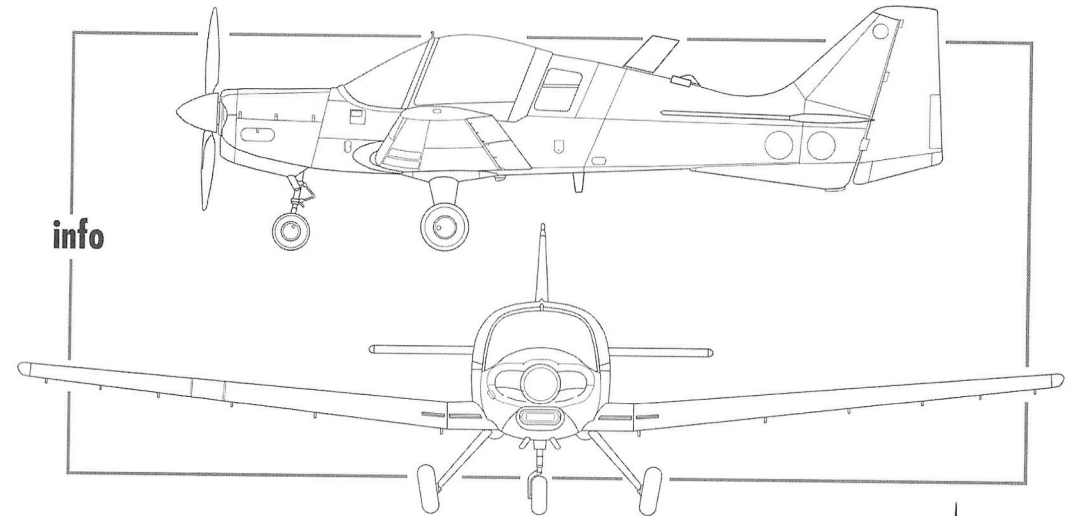

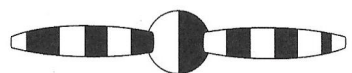
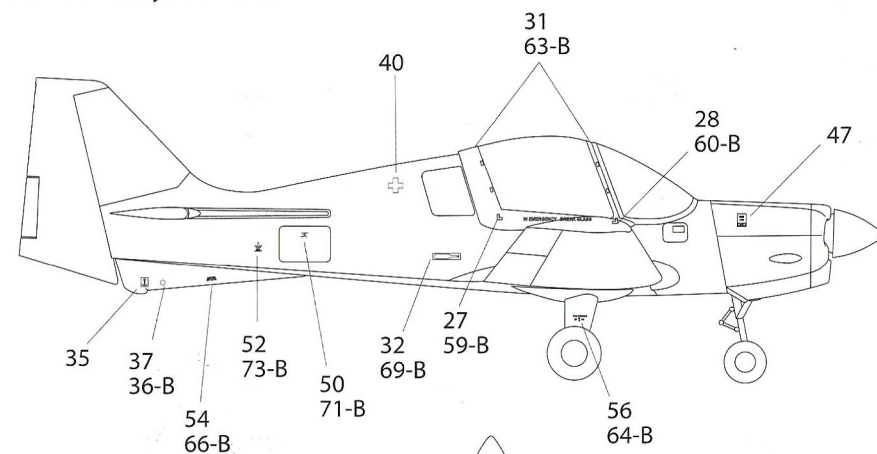
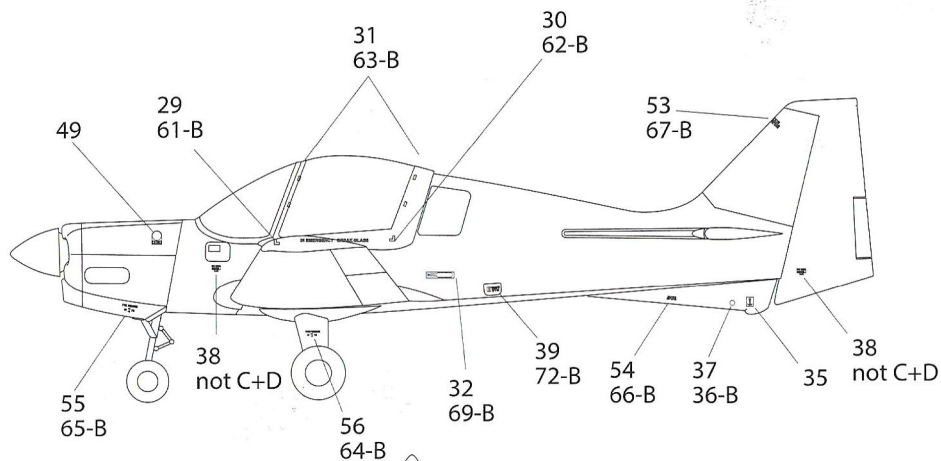

Propeller front and spinner painting for RAF and Malta, back is black with yellow tips

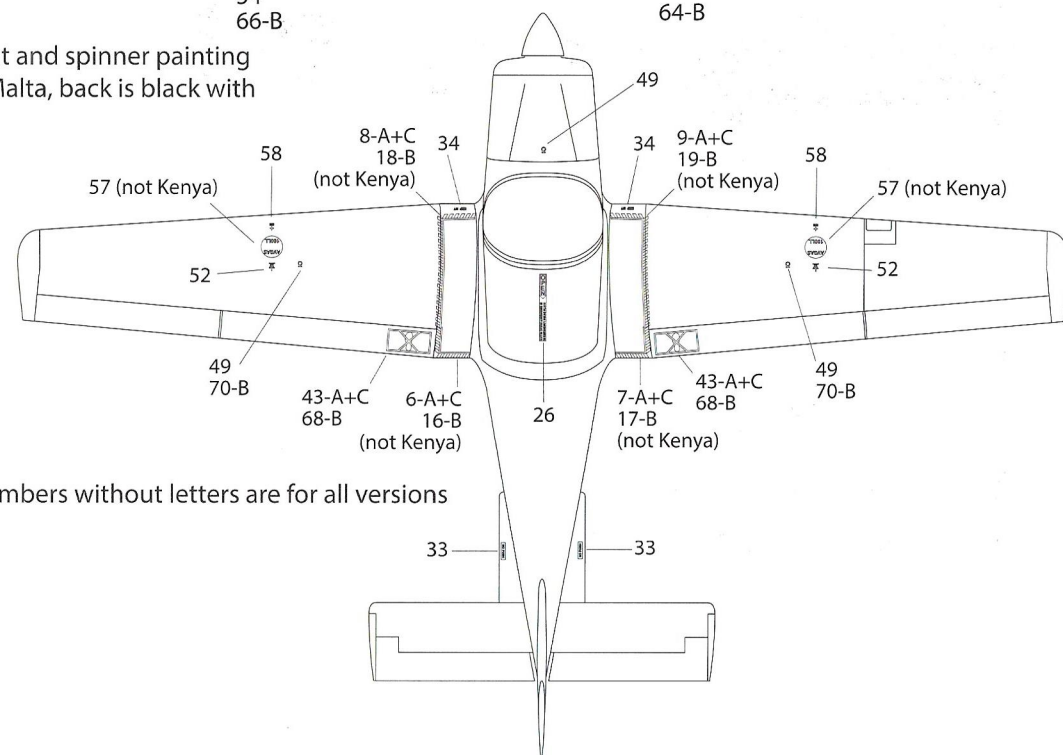
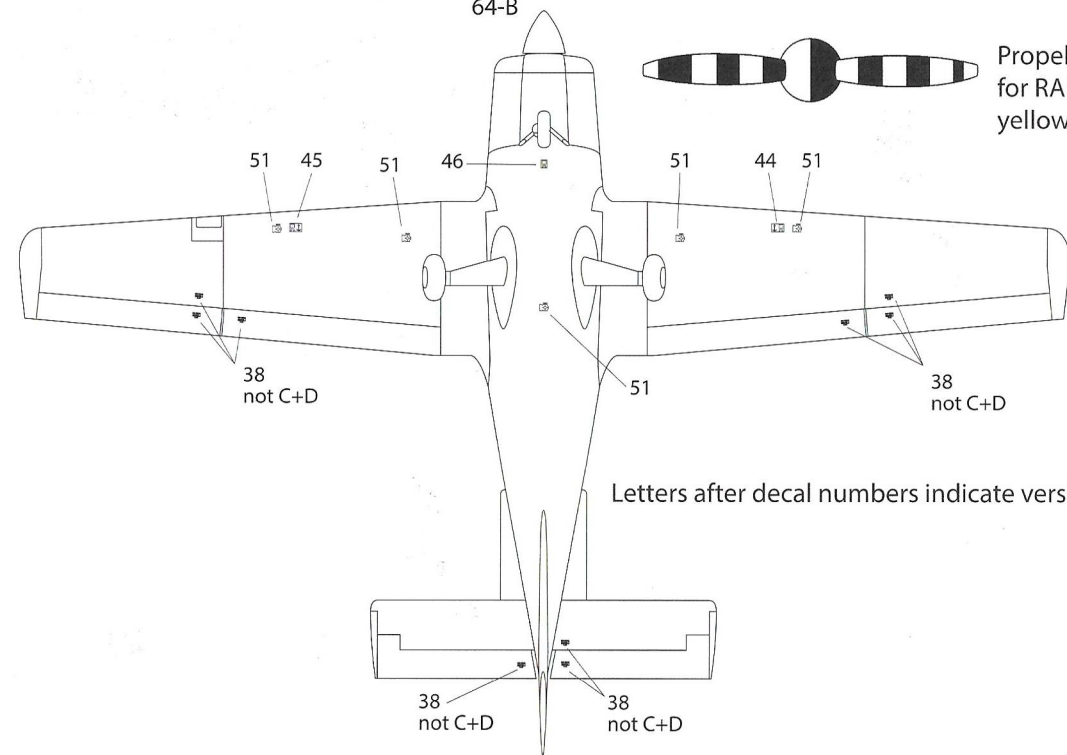

Letters after decal numbers indicate version. Numbers without letters are for all versions

- A** **537 Signal Red:** Gunze Sangyo H023, Humbrol 174
- B** **627 Light Aircraft Gray:** Gunze Sangyo H332, Humbrol 166
- C** **Gloss White:** Gunze Sangyo H001, Humbrol 22

- D** **Gloss Black:** Gunze Sangyo H002, Humbrol 21
- E** **Trainer Yellow:** Gunze Sangyo H329, Humbrol 24
- F** **Matt Black:** Gunze Sangyo H012, Humbrol 33





Version A - XX621 Yorkshire University Air Squadron



Version B - XX537 RAF East Lowlands Universities Air Squadron

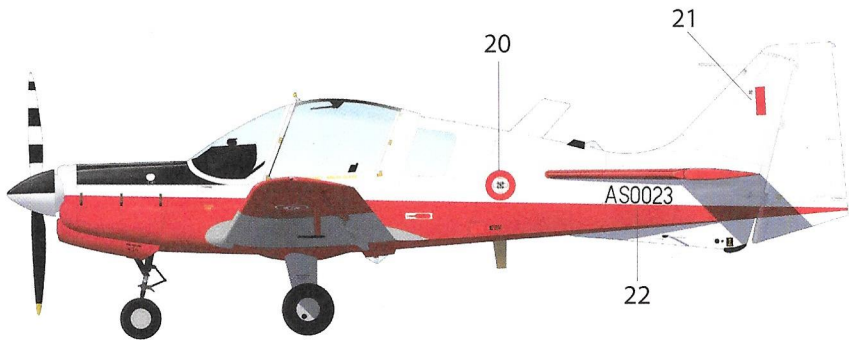

Version C - AS0023 Air Wing of the Armed Forces of Malta

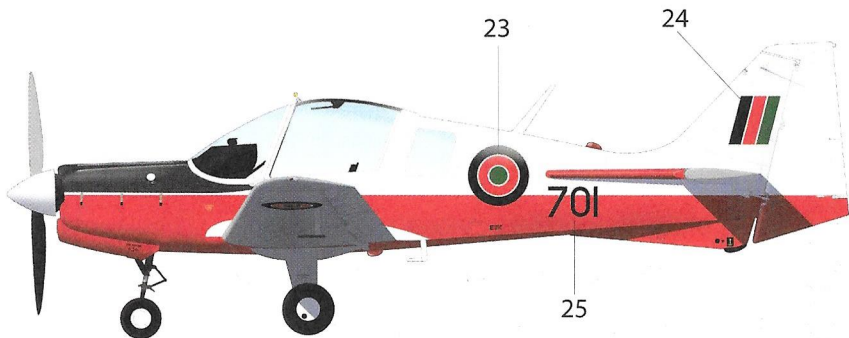

Version D - 701 Kenya Air Force

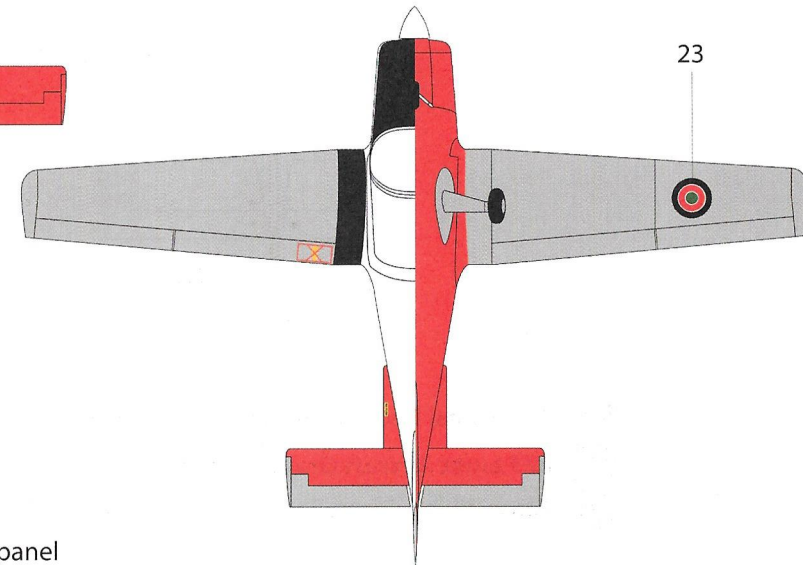
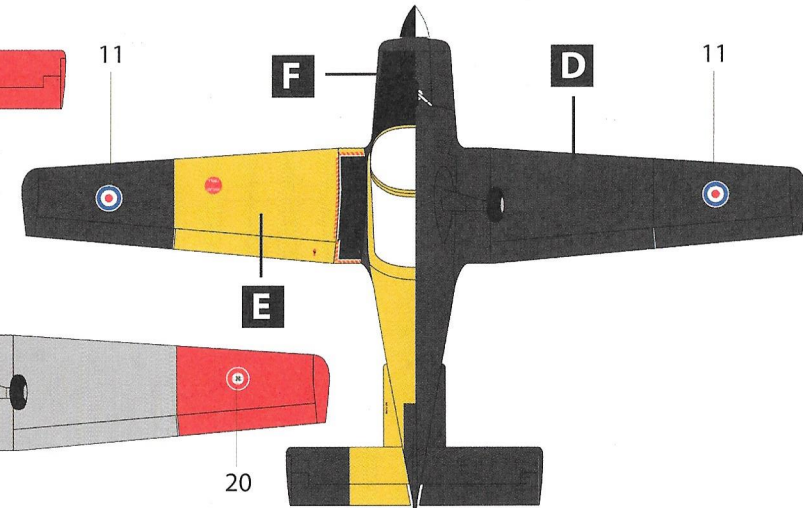
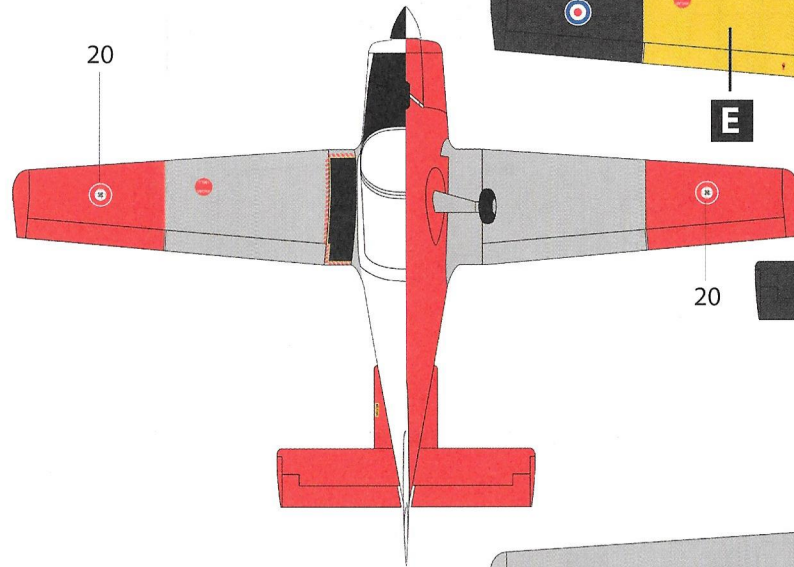
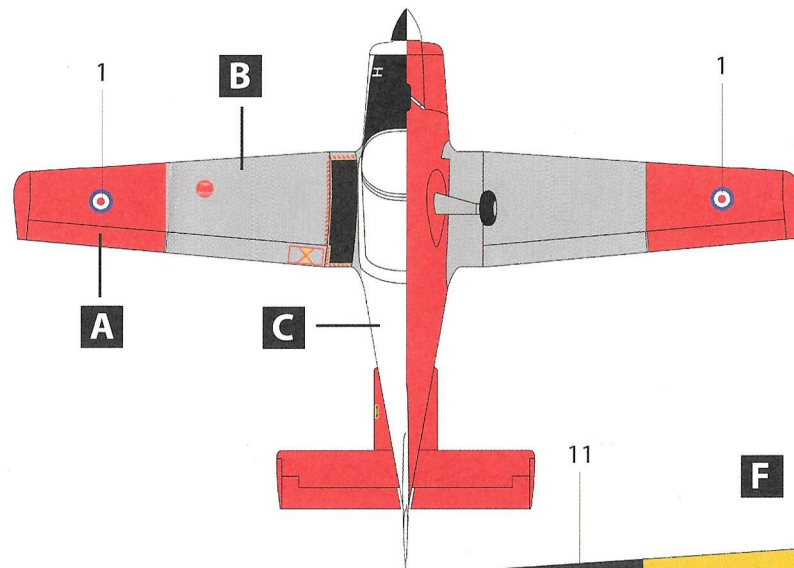

All Aircraft in gloss finish, except anti glare panel