

Plastic model kit containing 839 parts.

Wing span: 972mm Length: 664mm

1/32
SCALE



01E038

Avro Lancaster Grand Slam

History of the Avro Lancaster

From failure to success. The four-engine Avro type 683 Lancaster was developed from the disappointing twin-engine Manchester, which suffered from engine fires caused by its unreliable Rolls Royce Vulture engine-installation.

However, the basic Manchester airframe was of sound design. A logical solution was to increase the wingspan and replace the two Vultures with four Merlin engines. The engine-installation originally developed by Rolls-Royce for the Beaufighter II, was quickly adapted and fitted in graceful underslung nacelles. The prototype BT308 made its first flight on January 9th, 1941 and it soon proved to be an excellent aircraft with good handling and high load capability. Initially designated Manchester III, it was soon renamed Lancaster. The general outline of the Lancaster remained the same throughout production, apart from the MK II which used Bristol Hercules radial engines, in case a shortage of the Merlin should arise. The Mk I and III were similar, differing only in the type of

Merlin engine fitted. In the case of the Mk III, the Packard built Merlin 28 was utilised. The Lancaster began to equip bomber squadrons in early 1942, where it quickly became the backbone of RAF Bomber Command.

The type was used in many famous raids, such as on the M.A.N. factory in Augsburg, the spectacular Dambusters Raid on the Ruhr Valley dams, and sinking the "Tirpitz" to name but a few. It became famous for its use in high accuracy bombing operations by 617 squadron. Its 33-foot-long bomb bay enabled it to carry high loads as well as the spinning "Upkeep" mine used to break the Ruhr dams. Specially adapted aircraft could carry the massive 12.000 lb "Tallboy" and 22.000 lb "Grand Slam" earthquake bombs.

At the end of the war it was also used for food dropping sorties for the starving Dutch population and transporting the many prisoners of war back home from Germany. Postwar Lancasters were used for testing jet engines and in-flight refueling system. As a bomber it was gradually replaced, but it found a useful role in Coastal Command until the last one was withdrawn in October 1956. The RCAF and French l'Aéronavale, however, continued to use the Lancaster until the mid-sixties. A total of 7,377 Lancasters were built in the UK and Canada.



BE CAREFUL



REMOVE



GLUE TOGETHER



PLEASE WAIT FOR A FEW MINUTES UNTIL DRY



MAKE 2 PIECES



DRILL HOLE



DO NOT GLUE



INSTANT GLUE FOR METAL



BEND



FILL HOLE



SEQUENCE OF WORK



OPTIONAL



USED COLOUR



APPLY DECAL



MARKING OPTION

CAUTION

When using both glue and paint, do not use these near an open flame, due to the flammable properties of these items.

The symbols provided, such as 'X', refer to the basic colours of parts, although a more comprehensive list is supplied for your use for Tamiya, Mr Hobby and AK-Interactive codes.

When removing parts from sprues, take extreme care. Consider correct tools such as Xuron Sprue Cutters

Please check the symbology on the left and familiarise yourself before building this model kit.

In cooperation with:



www.ak-interactive.com



HK MODELS 01E038

PAGE 01

This small instruction booklet is used to build 'Grand Slam', follows the main instruction of the Lancaster Mk 1, with the exception of the following steps:

1

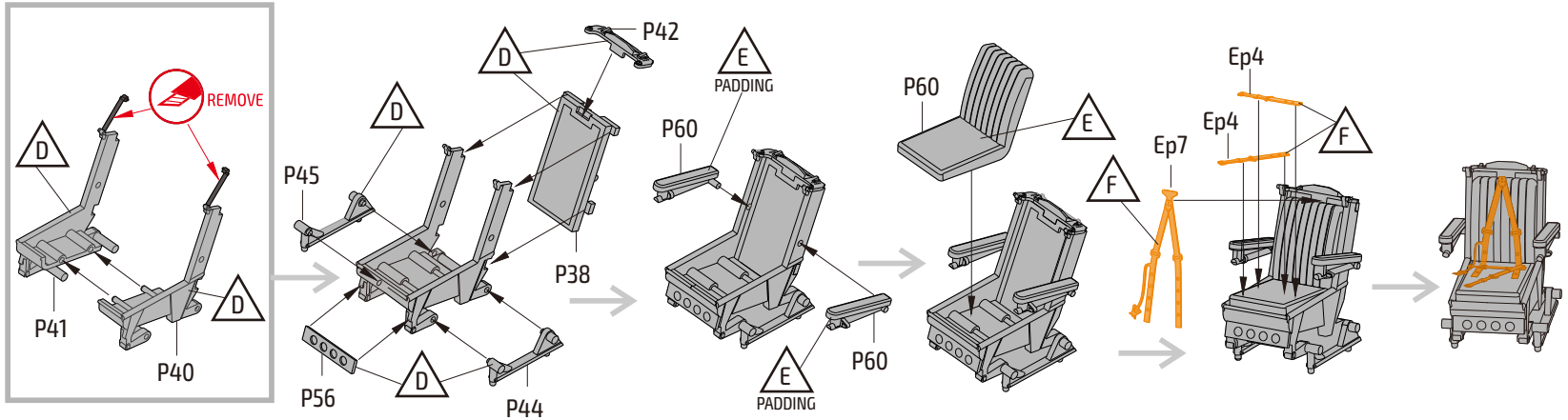

11

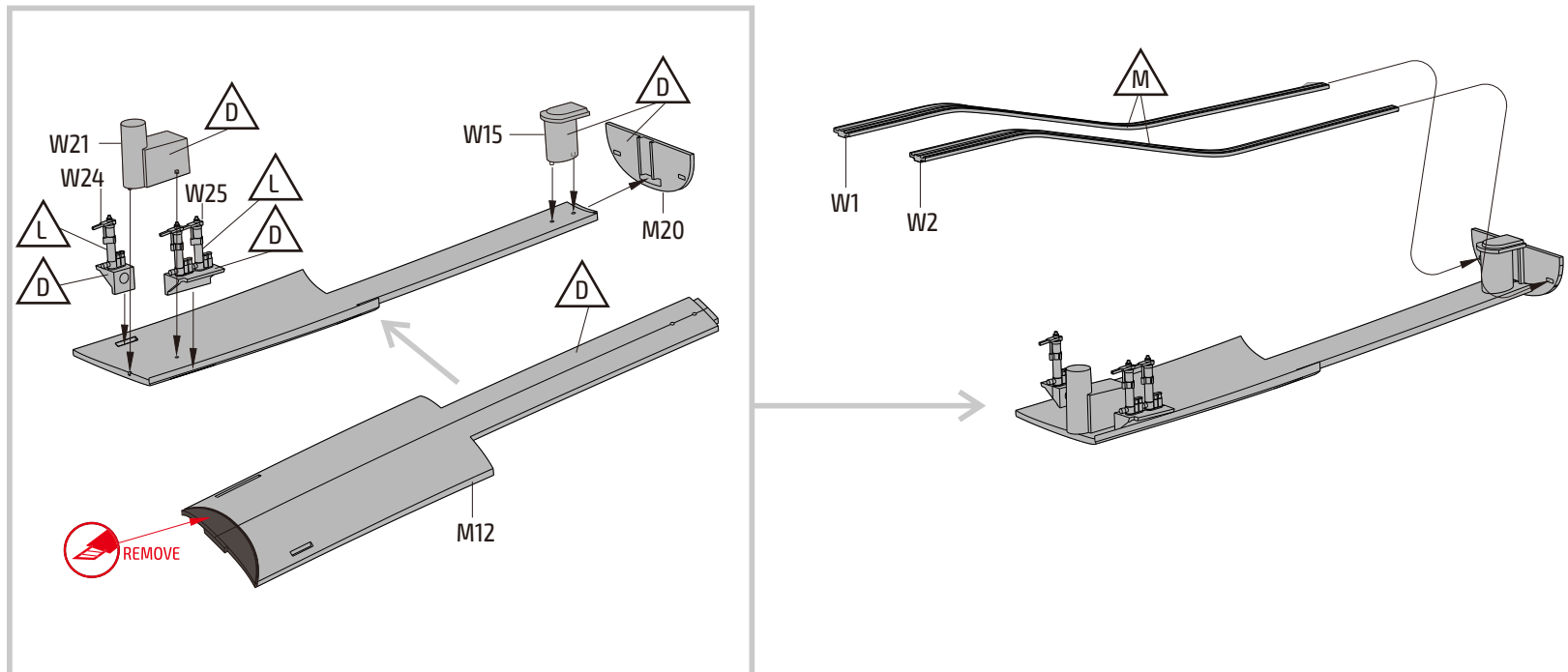

12

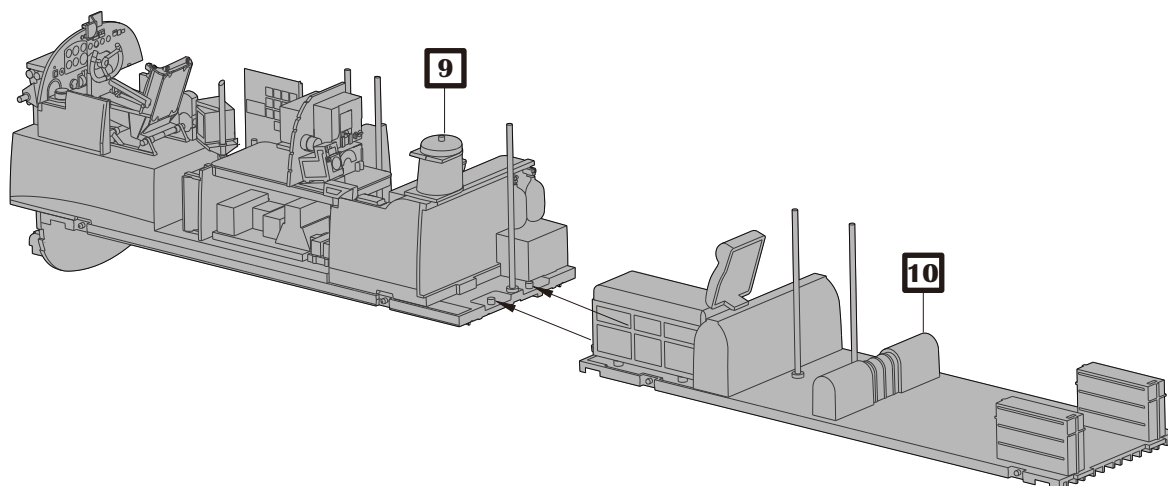

15

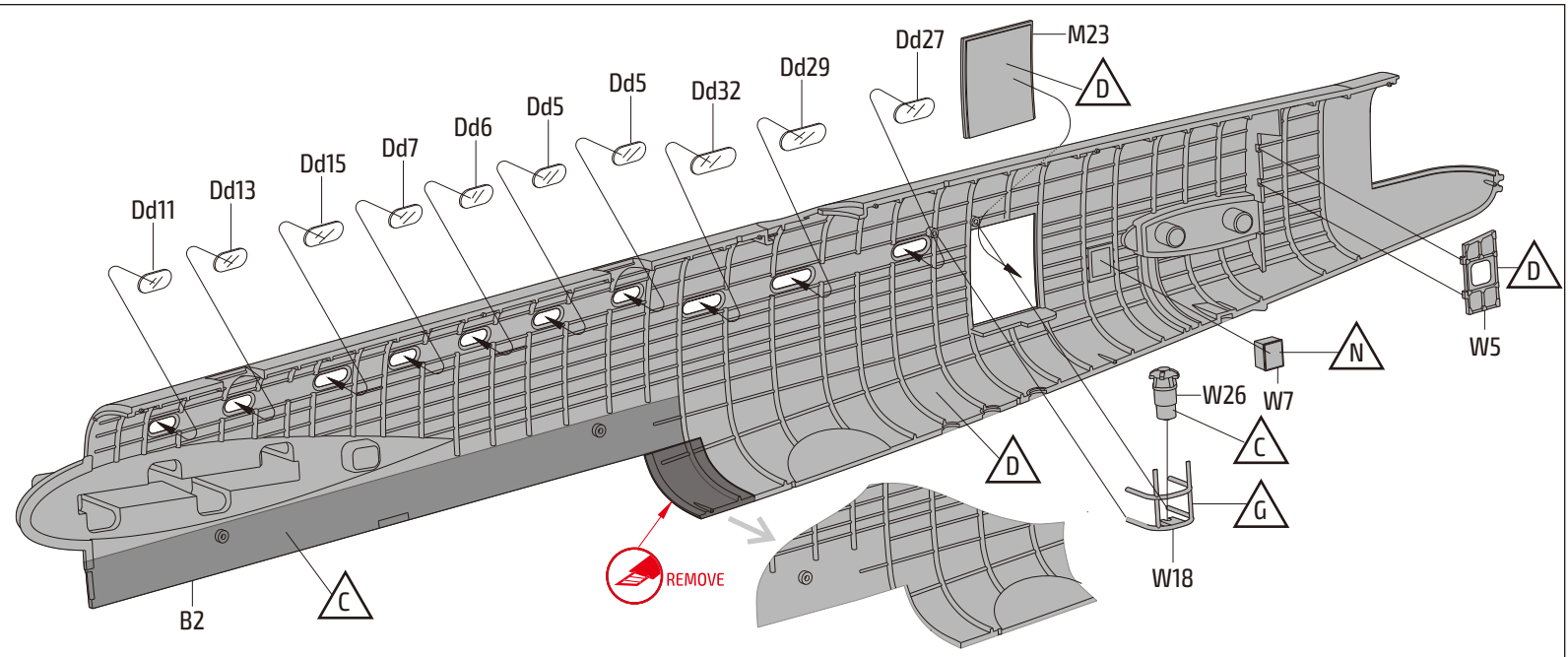

16

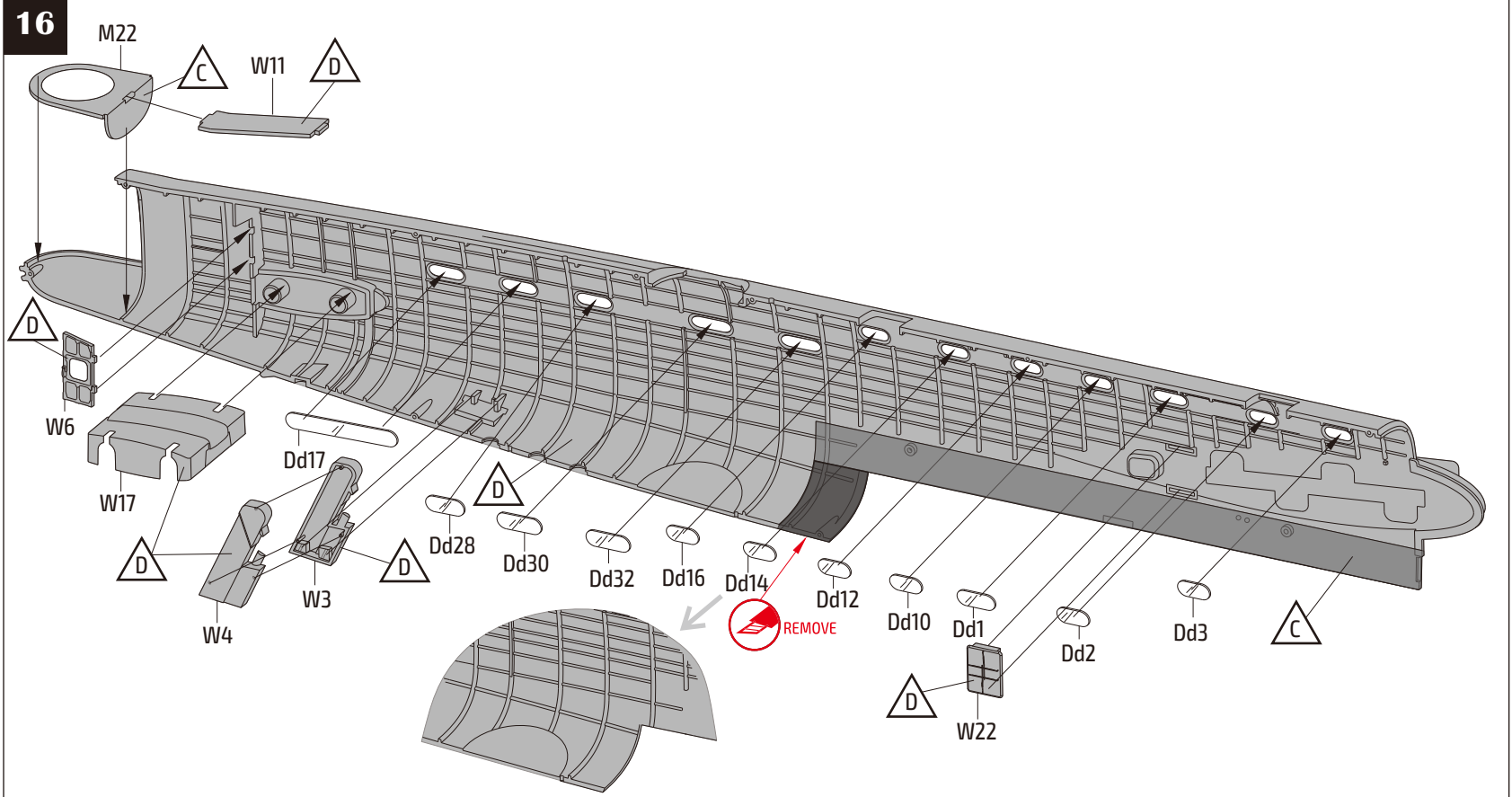

19

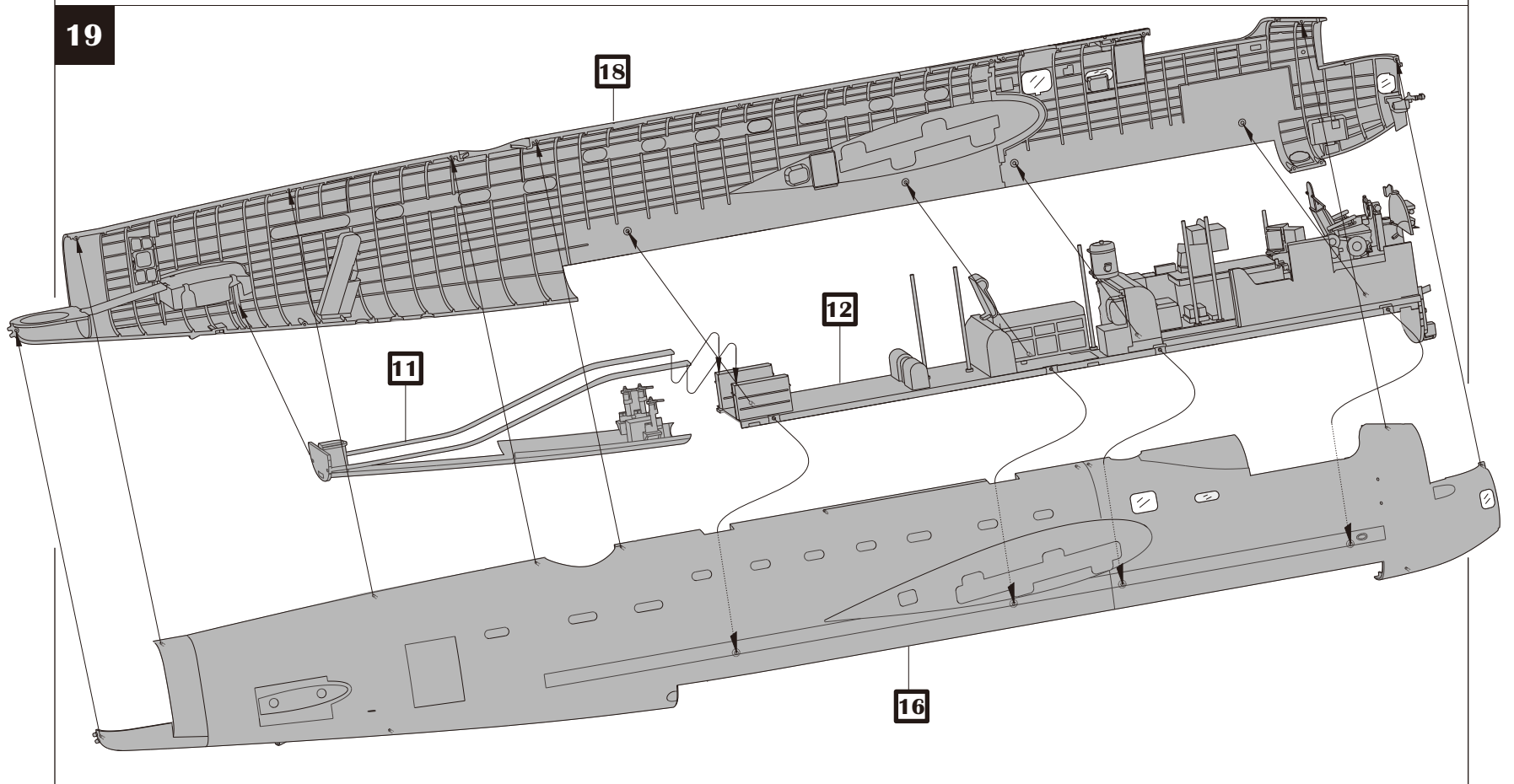

23

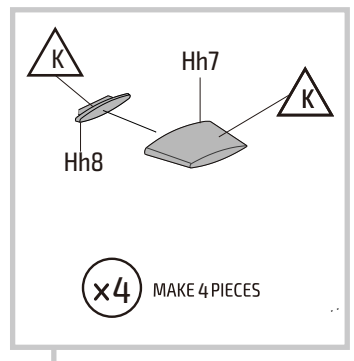
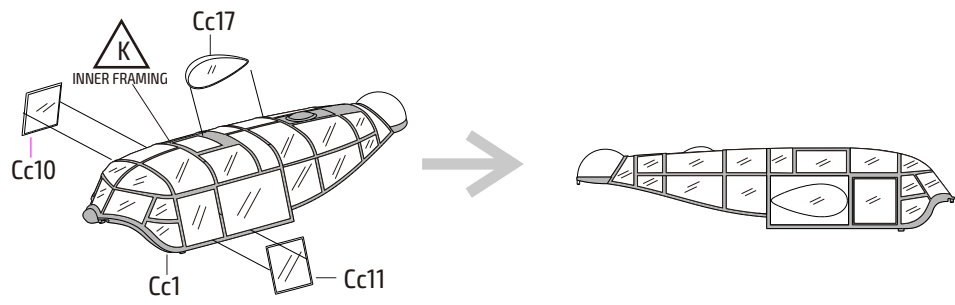

27

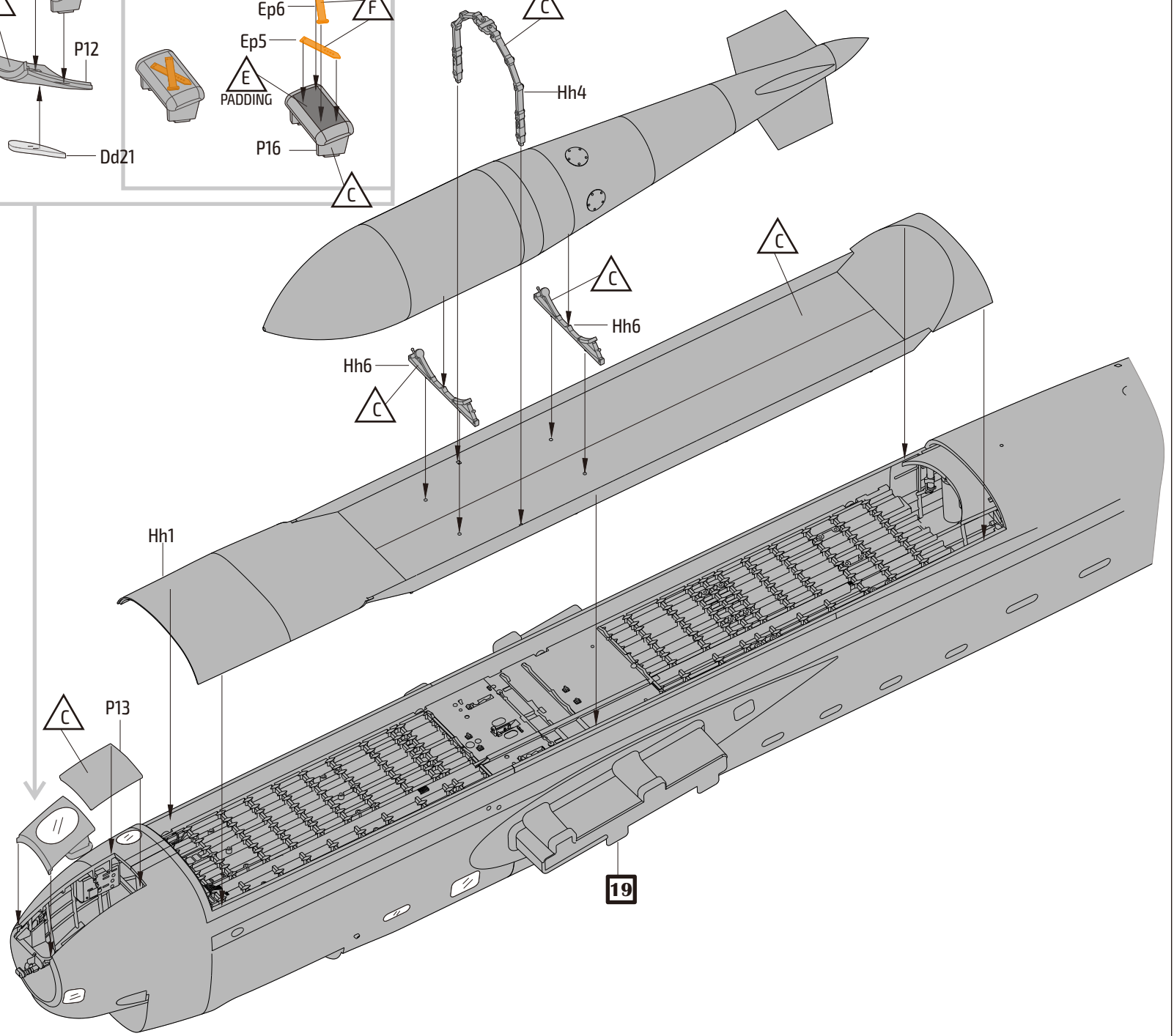
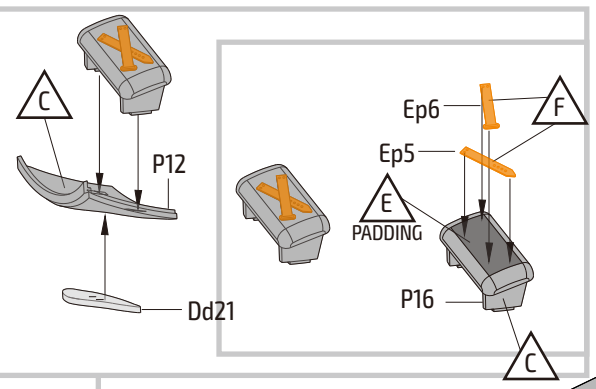
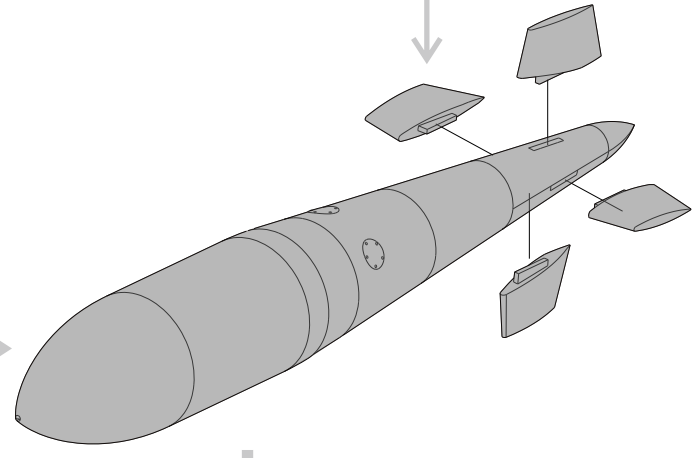
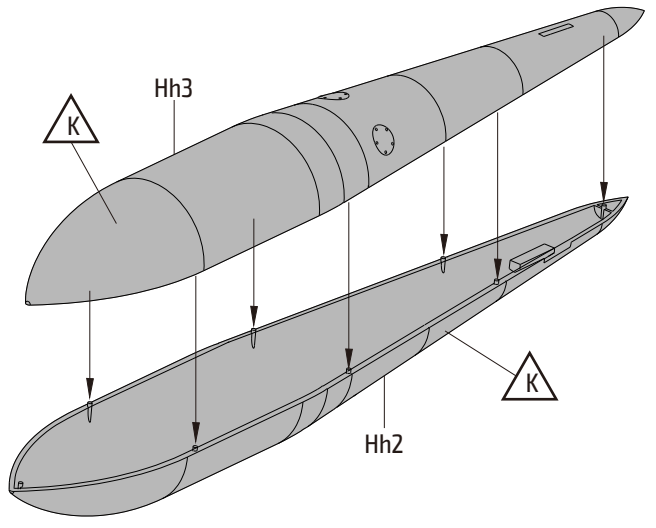

35

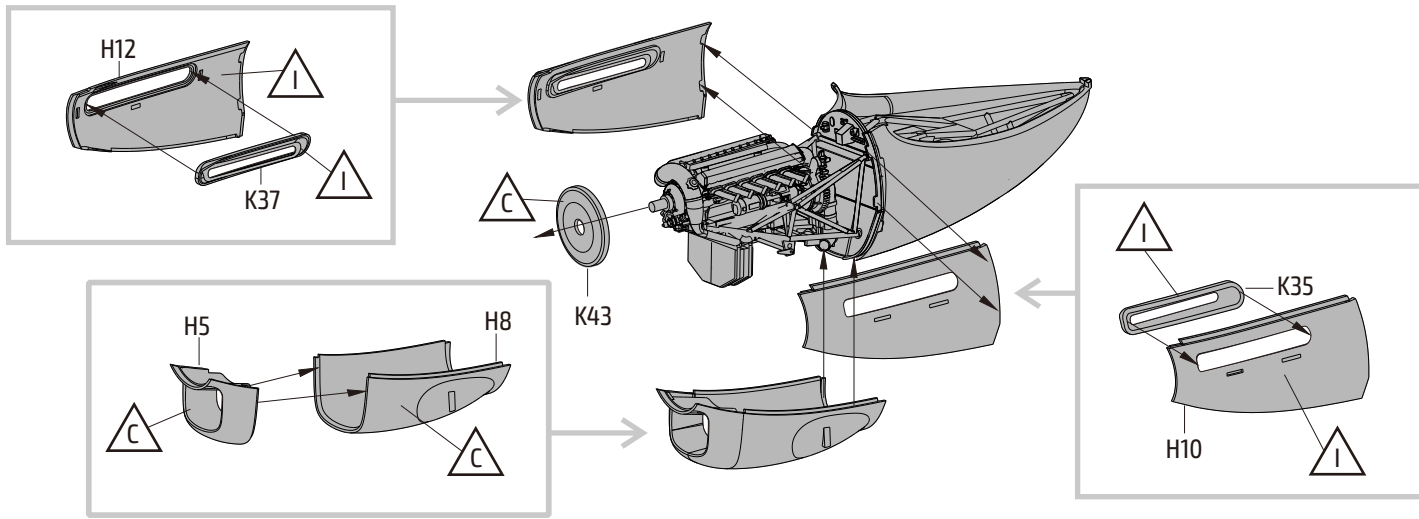

38

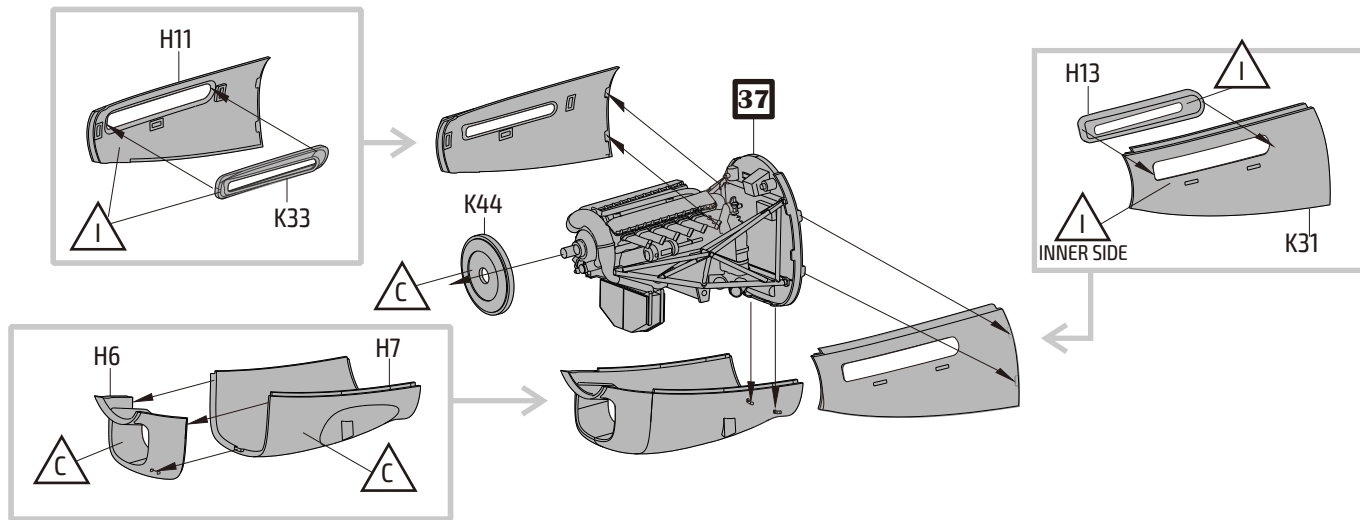

52

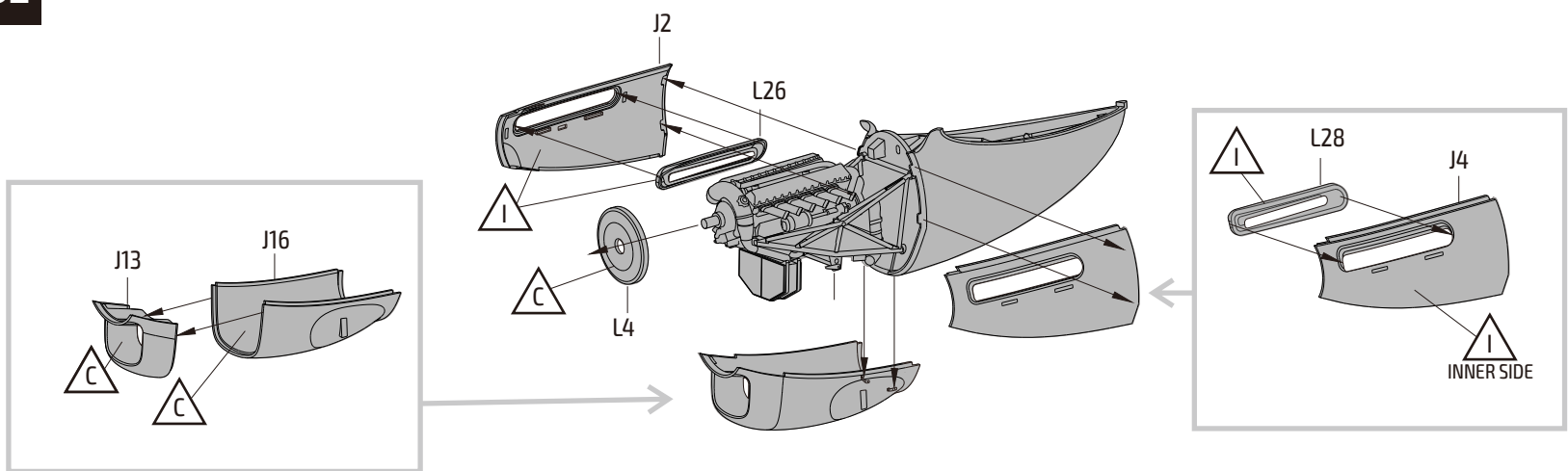

57

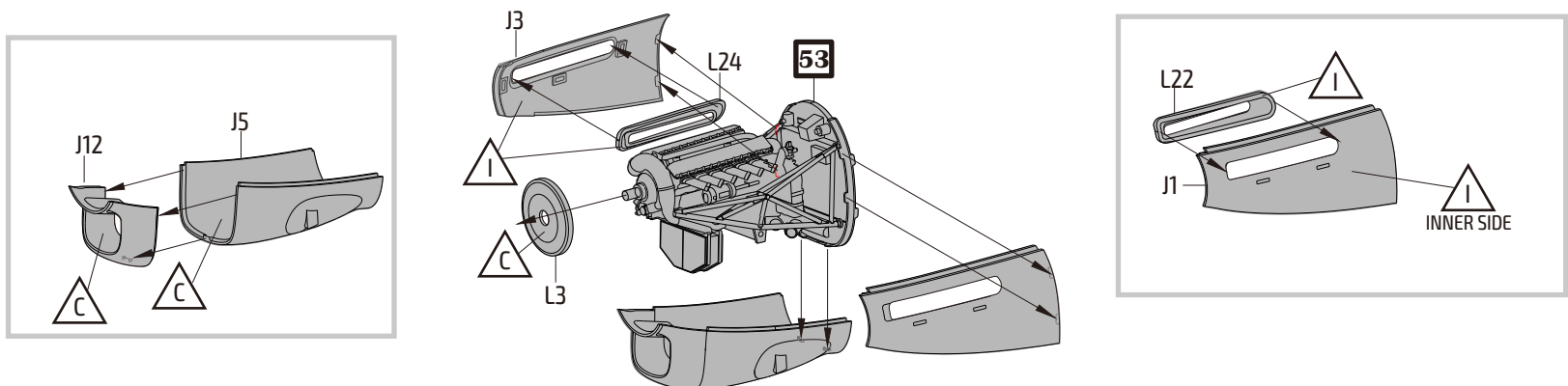

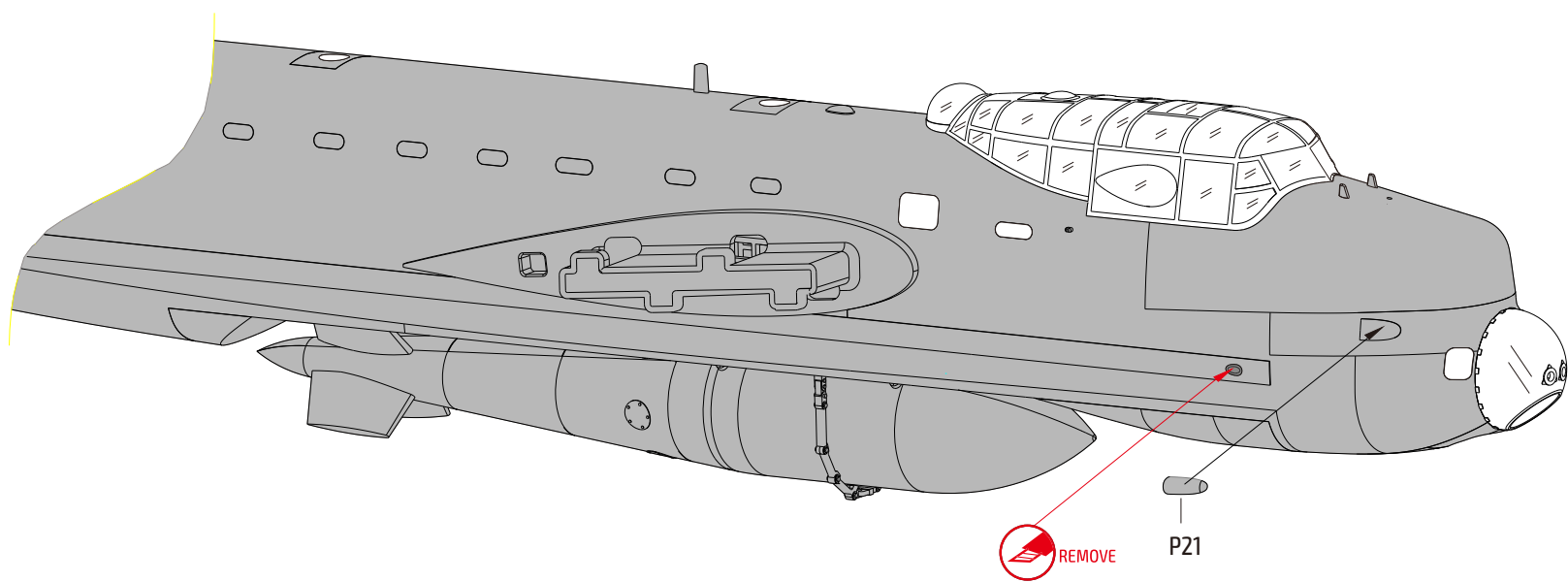
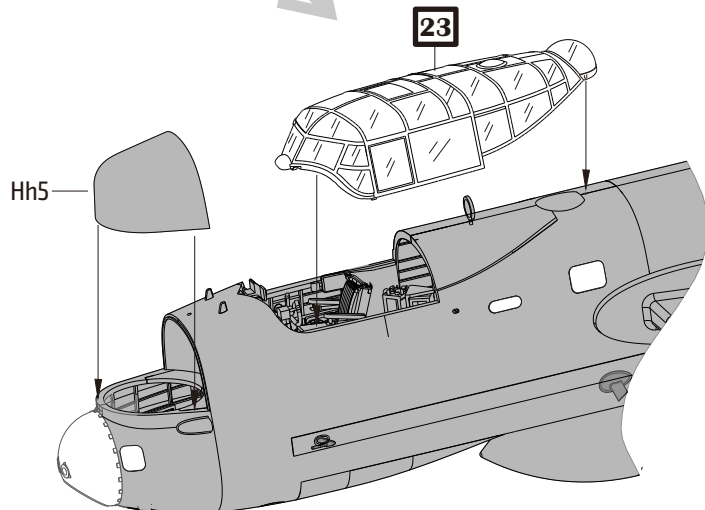
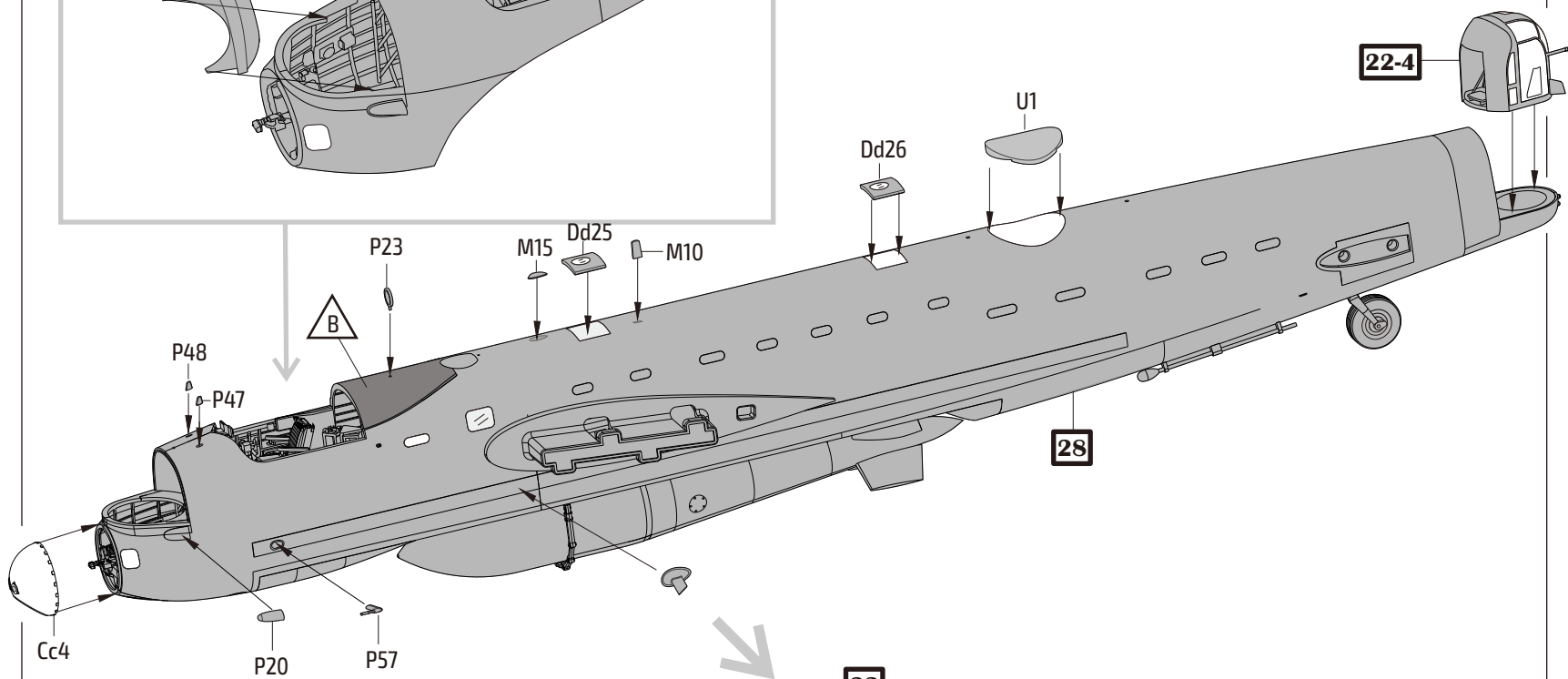
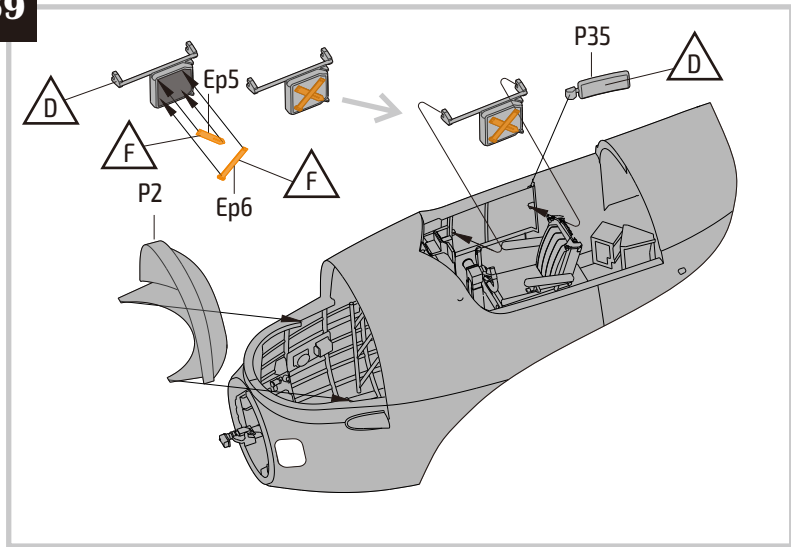

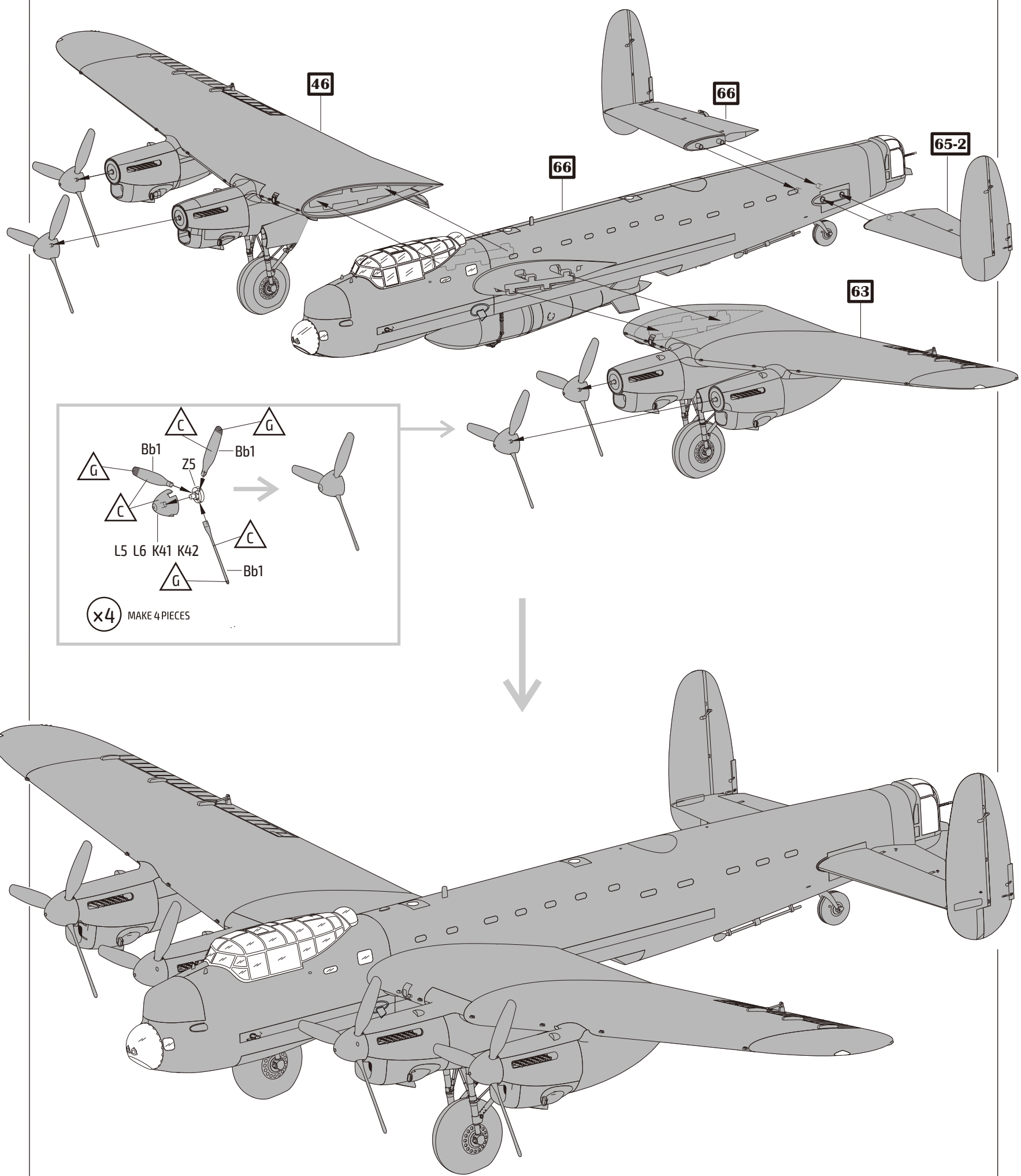

Parts

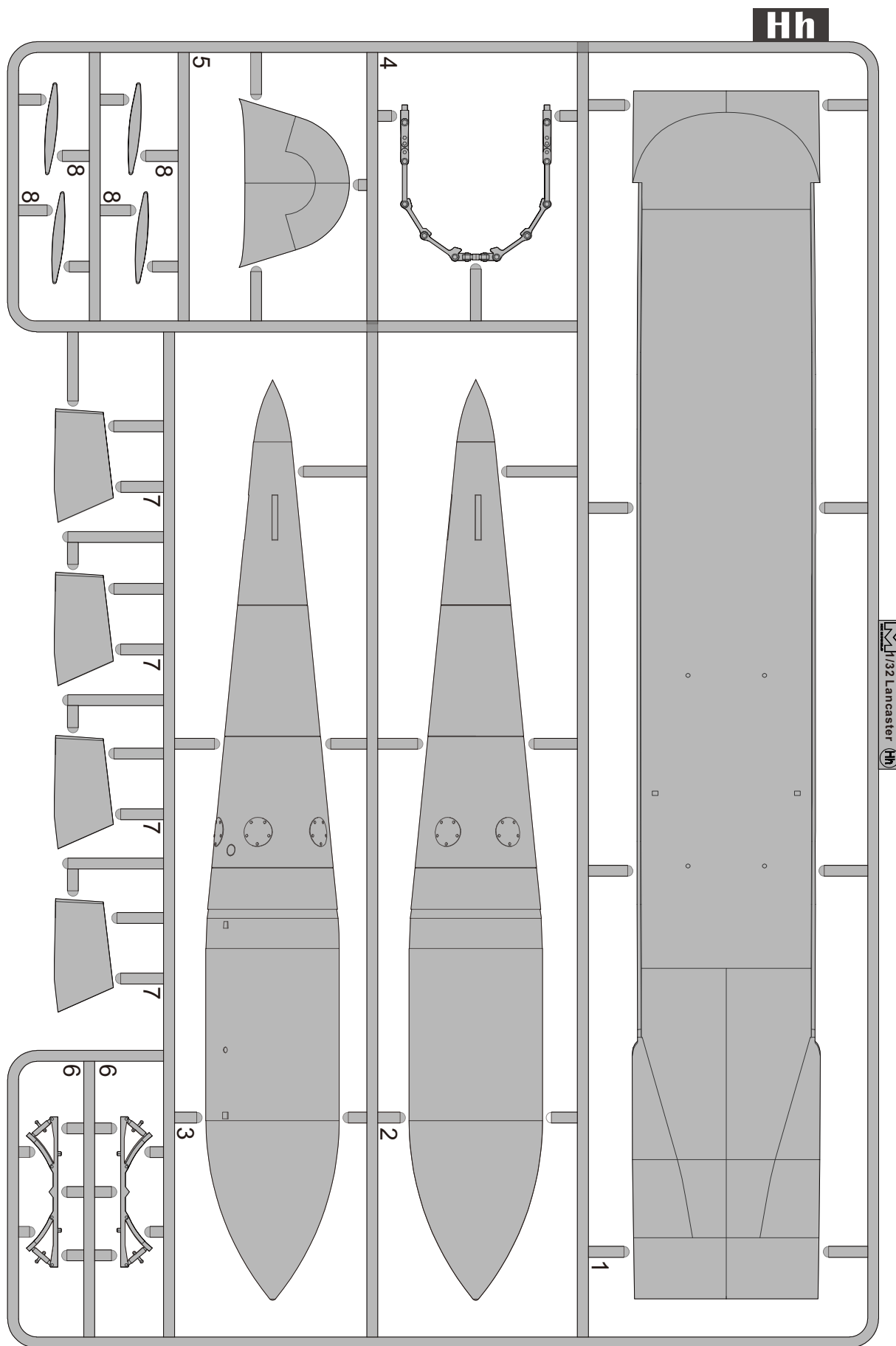

1/32 Lancaster Hh

Decal images

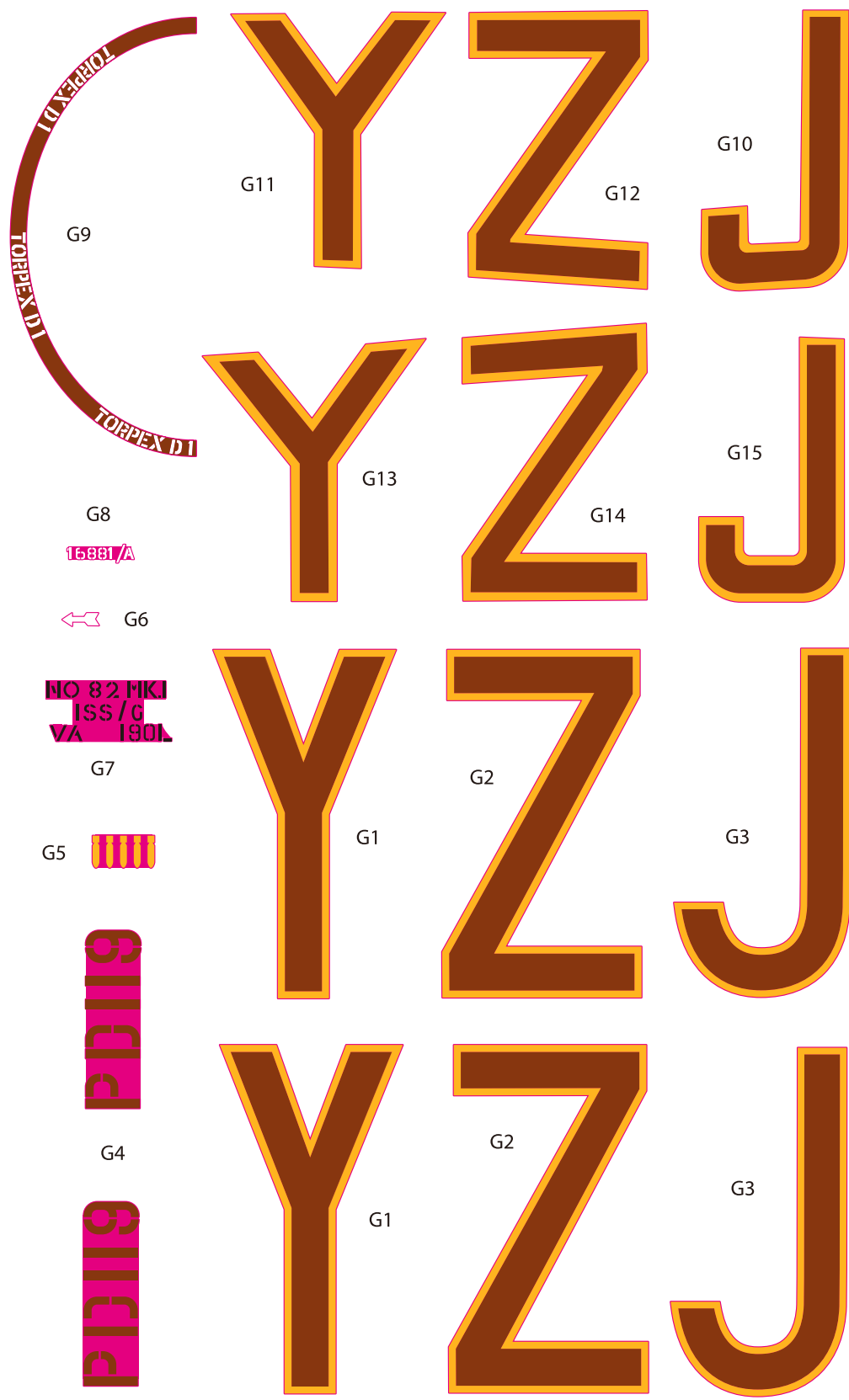

Avro Lancaster B Mk.I Special "Grand Slam"

HK Models 01E038

MARKING

A

B Mk.I Special, PD119/YZ-J, No.617 Sqn. RAF, Woodhall Spa, UK, April 1945

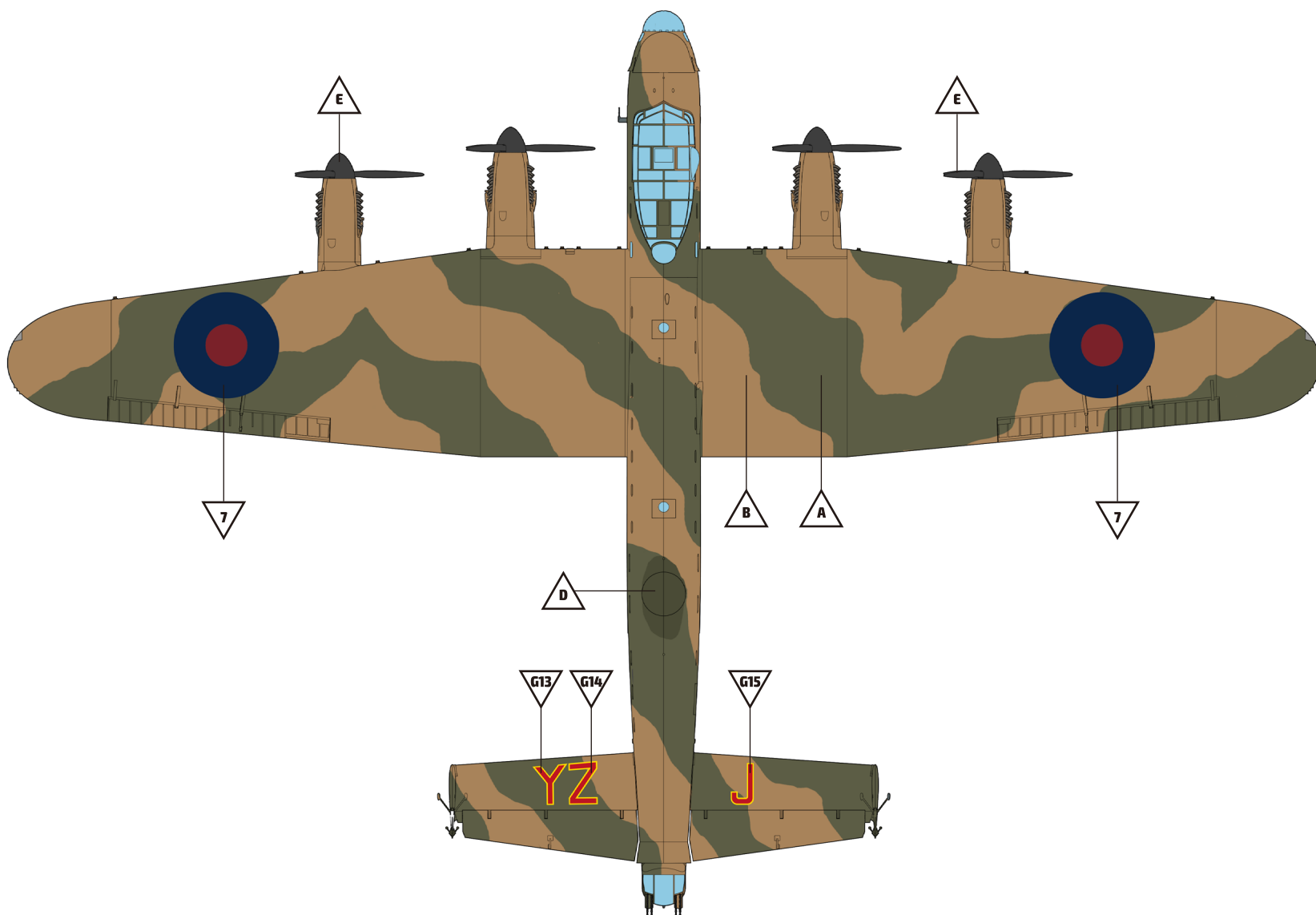
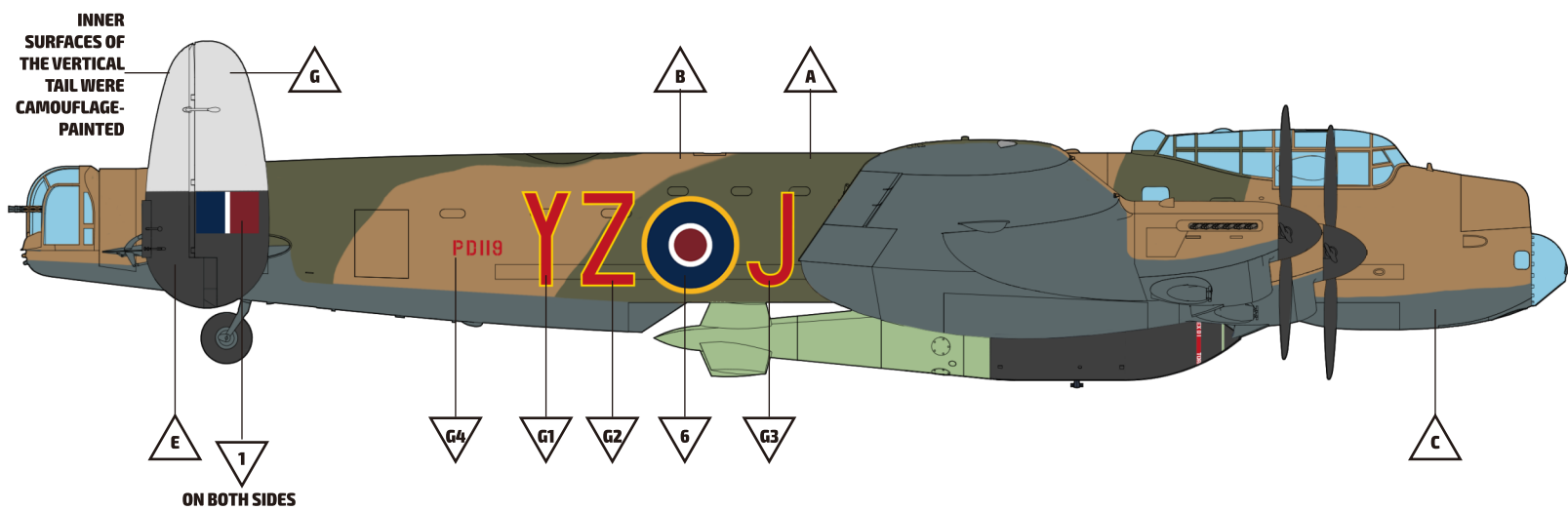

MARKING

A

B Mk.I Special, PD119/YZ-J, No.617 Sqn. RAF, Woodhall Spa, UK, April 1945

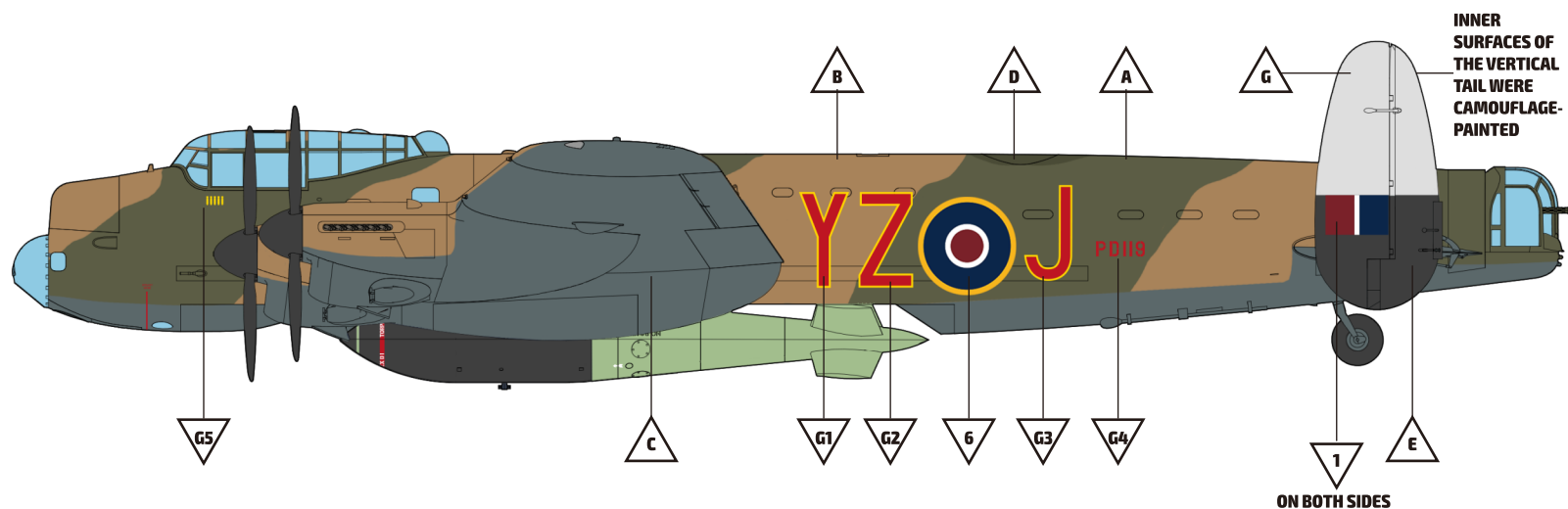

INNER SURFACES OF THE VERTICAL TAIL WERE CAMOUFLAGE-PAINTED

ON BOTH SIDES

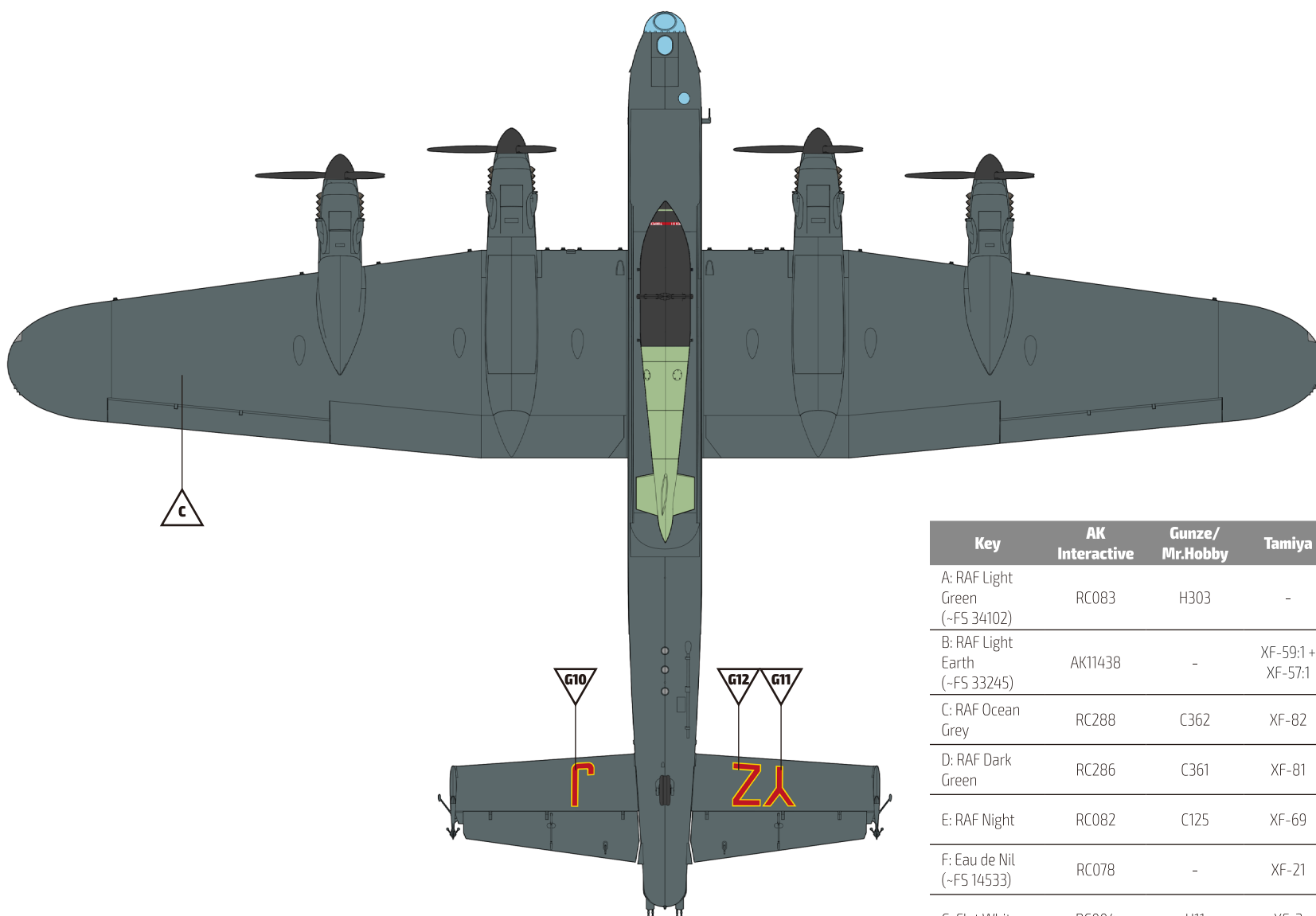
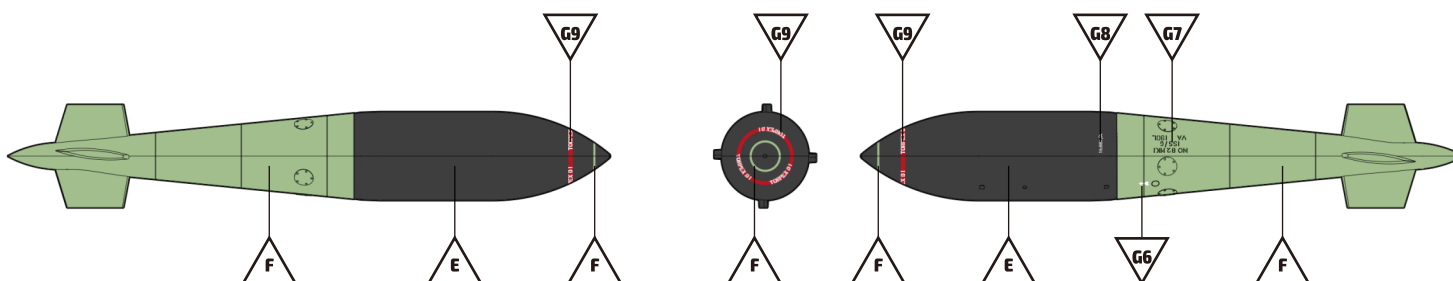

Key	AK Interactive	Gunze/Mr.Hobby	Tamiya
A: RAF Light Green (~FS 34102)	RC083	H303	-
B: RAF Light Earth (~FS 33245)	AK11438	-	XF-59:1 + XF-57:1
C: RAF Ocean Grey	RC288	C362	XF-82
D: RAF Dark Green	RC286	C361	XF-81
E: RAF Night	RC082	C125	XF-69
F: Eau de Nil (~FS 14533)	RC078	-	XF-21
G: Flat White	RC004	H11	XF-2

Colour Guide

Key	AK Interactive	Tamiya	Gunze/Mr.Hobby
A: RAF Dark Green	RC286	XF-81	C361
B: RAF Dark Earth	RC287	XF-52:4 + XF-3:2 + XF-51:1 + XF-2:1	C369
C: RAF Night	RC036	XF-69	C125
D: RAF Interior Green	RC293	XF-71	C364
E: Dark Green Leather	AK2063	X-5	H6
F: Tan	RC019	XF-78	H27
G: Flat Yellow	RC008	XF-3	H413
H: Flat Red	RC006	XF-7	H13
I: Aluminium	AK479	XF-16	MC218
J: Gunmetal	RC015	X-10	MC214
K: Olive Drab	RC259	XF-62	H52
L: Steel	AK476	XF-56	MC213
M: Brass	AK475	X-12	MC219
N: Flat White	RC004	XF-2	H11
O: Rubber Black	RC022	XF-85	H77

In cooperation with:



www.ak-interactive.com

Illustration, manual layout and format: **HK Models, Tomek Wajnkaim & AK-Interactive**
 Manual and assistance: **AK-Interactive**
 Introductory text: **Cees Broere**
 Published & Printed version: **1nd Version**