



It is highly recommended that you visit [www.metalearth.com/360/icx126](http://www.metalearth.com/360/icx126) to see the completed model before assembling your own

ICX126



SILENCE

### TO CREATE THE BEST CONNECTIONS

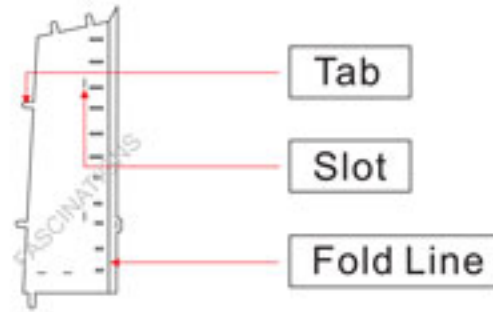

**Legends:**

- Engraved/Color side
- Non-engraved/Silver side
- Attention point
- Insert tab and bend 90 degrees
- Insert tab and twist 90 degrees

**Assembly tip:**  
If needed, slightly twist tabs to hold parts together then untwist and bend them down for a nice finish

**Recommended tools:**

-Wire cutters: helpful for taking parts from the metal sheets.



-Tweezers or needle nose pliers: helpful for folding parts, bending and twisting tabs.



### ASSEMBLY STEPS

Step 1

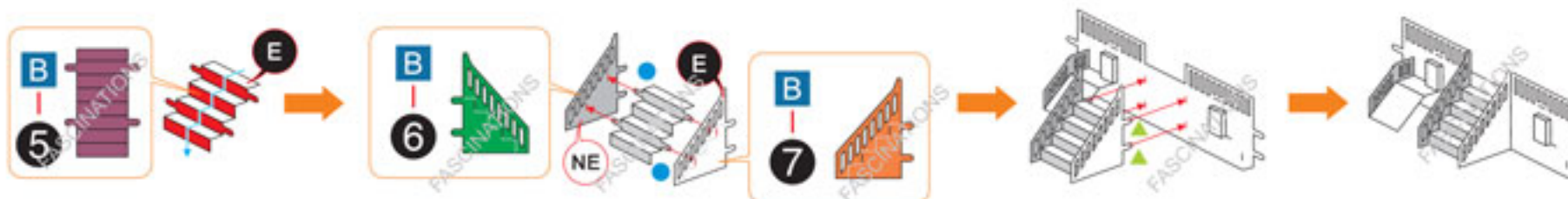
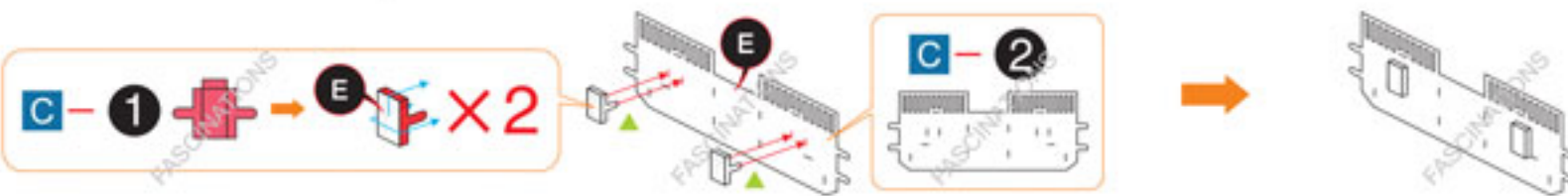

### METAL SHEET A

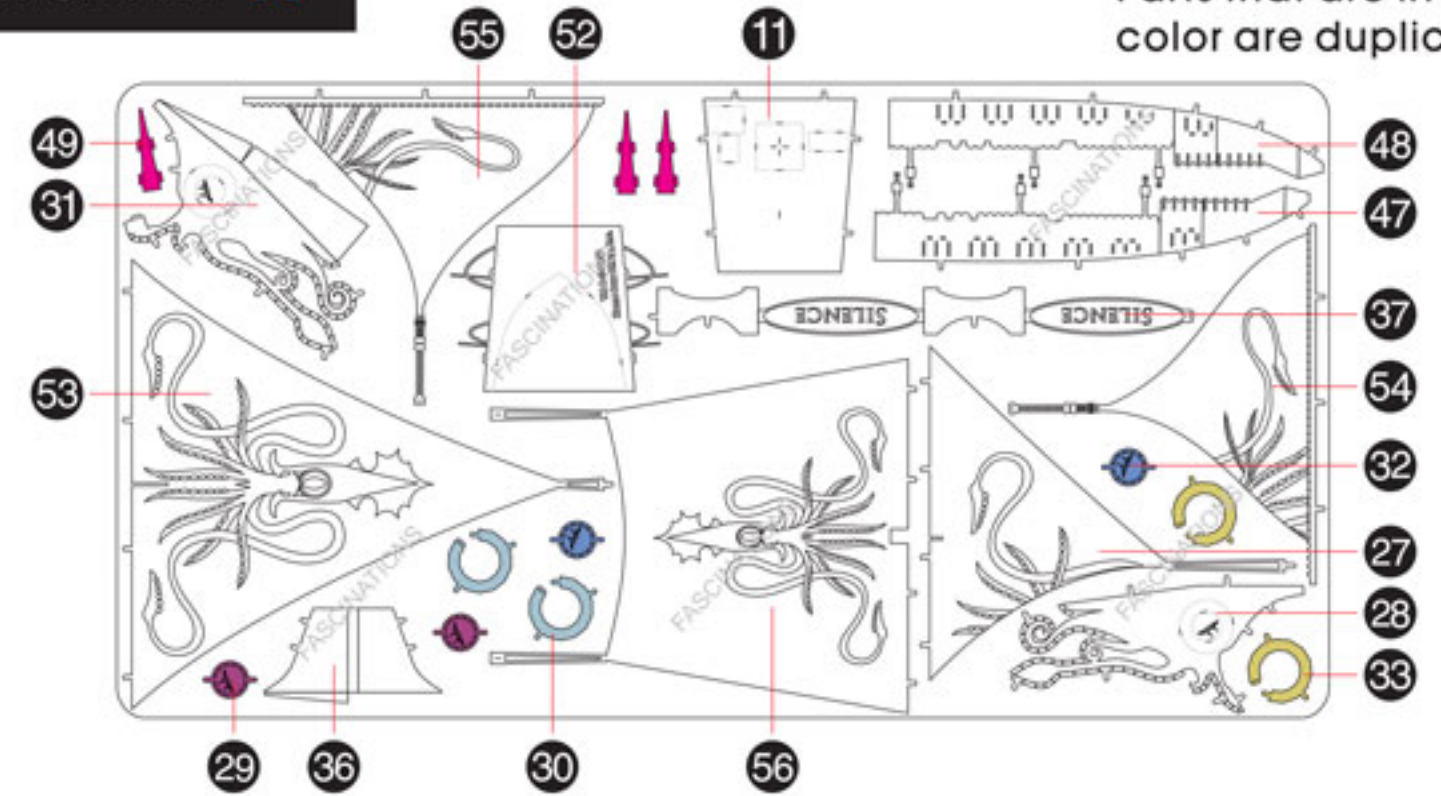

### METAL SHEET B

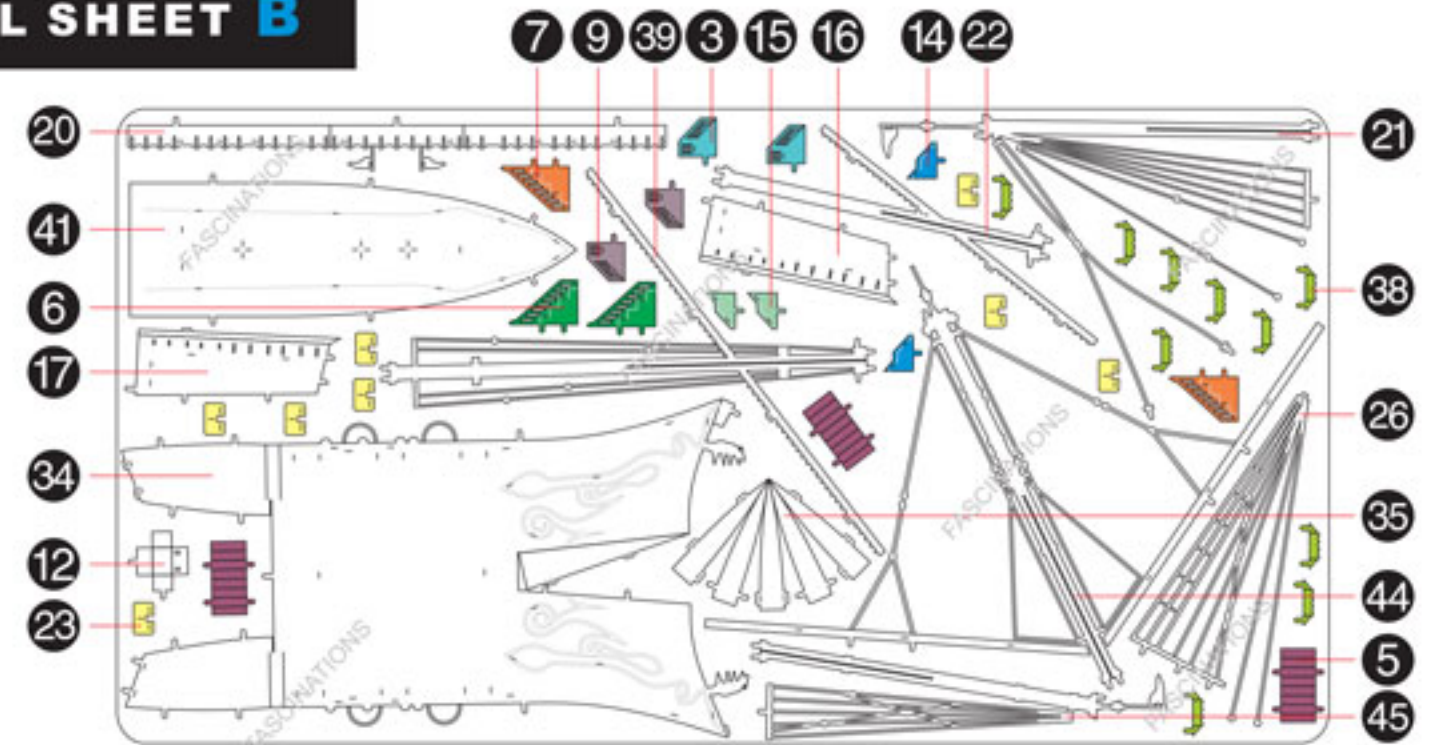

### METAL SHEET C

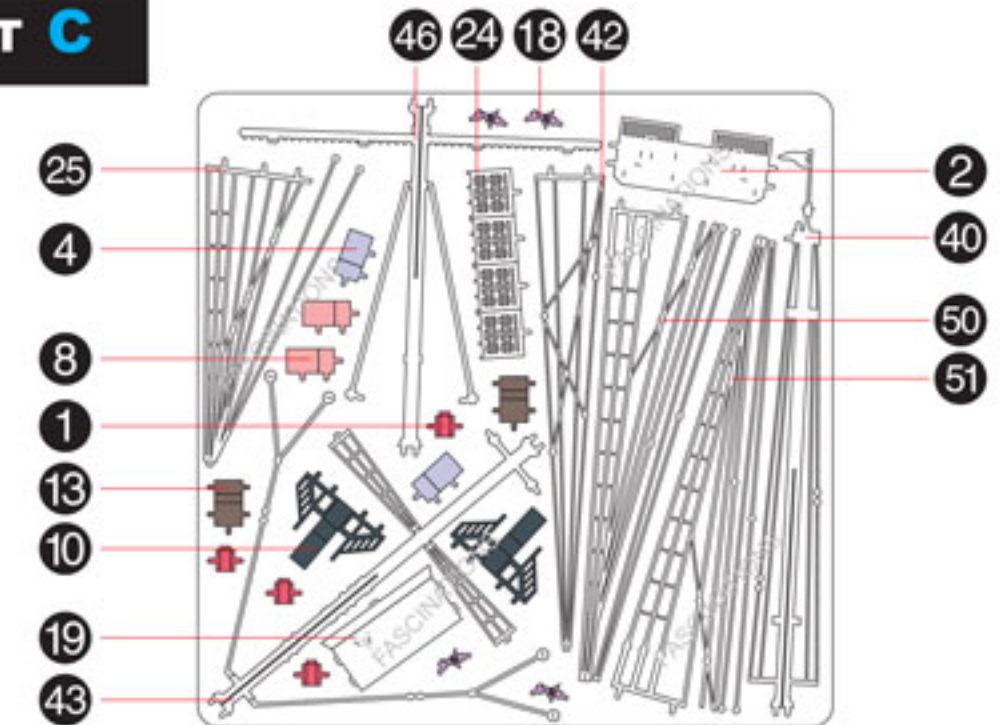

In order to avoid possible injury from sharp edges, please carefully discard the metal sheets after parts have been removed



### Step 2

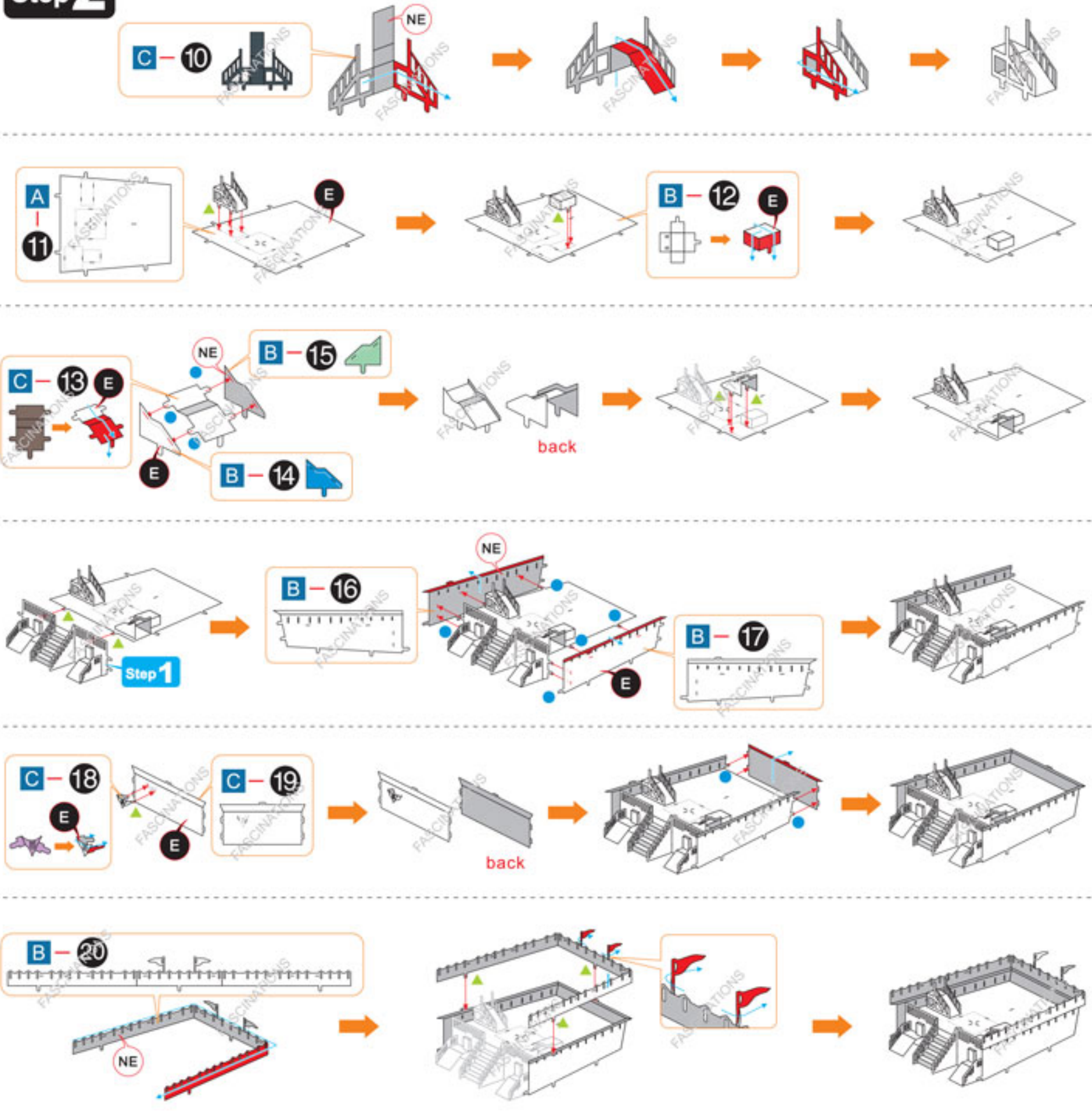

### Step 3

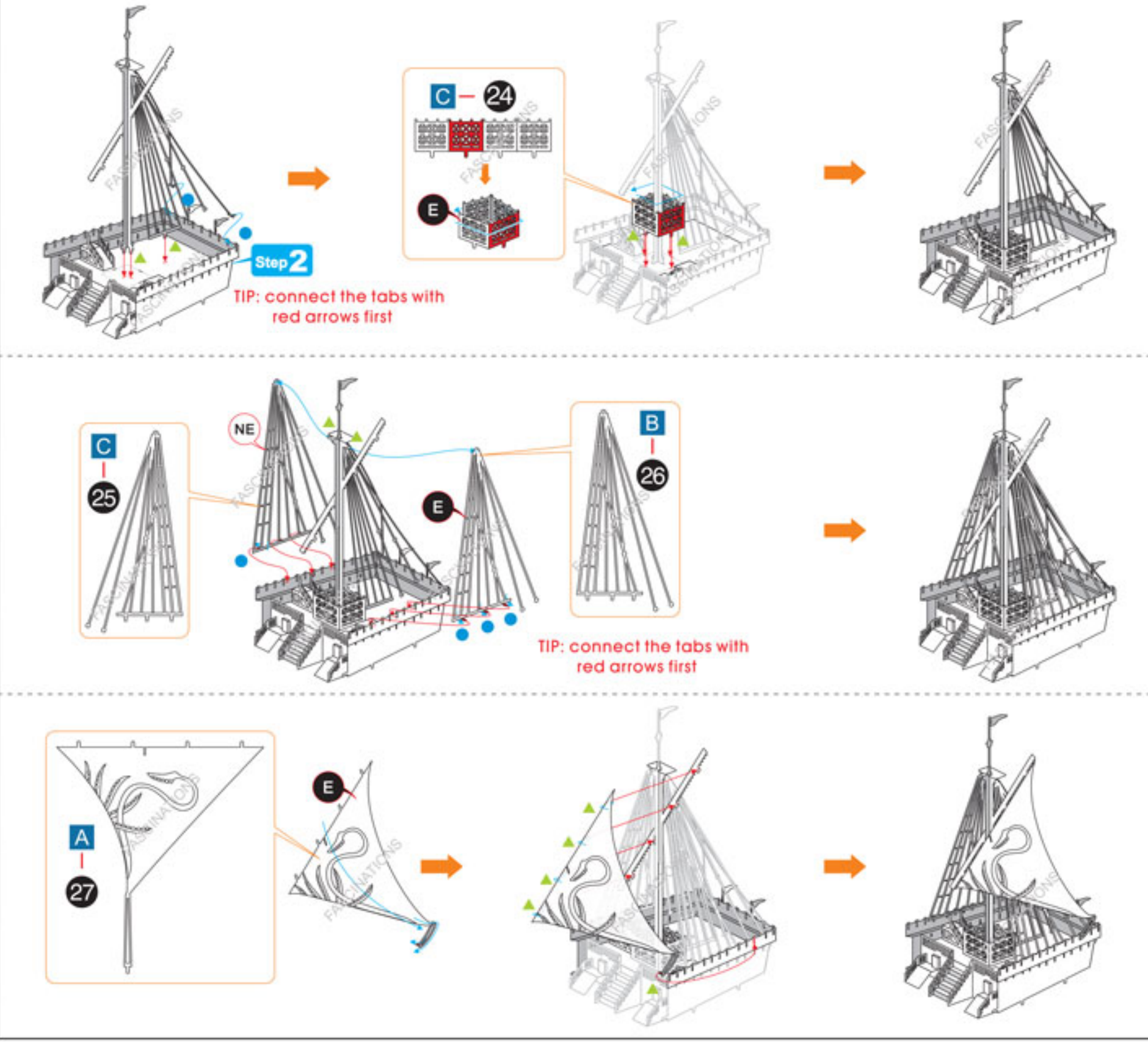
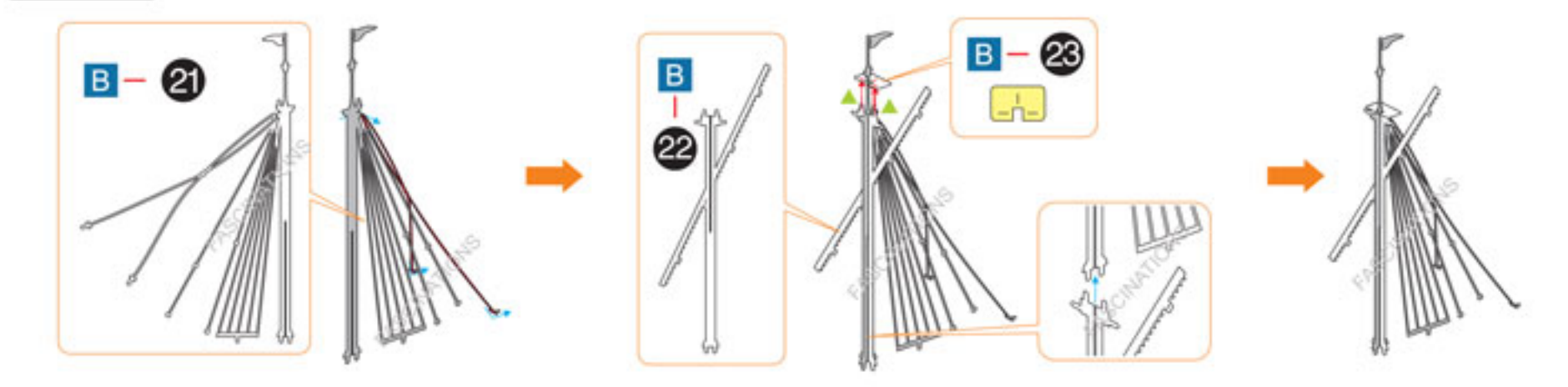

### Step 4

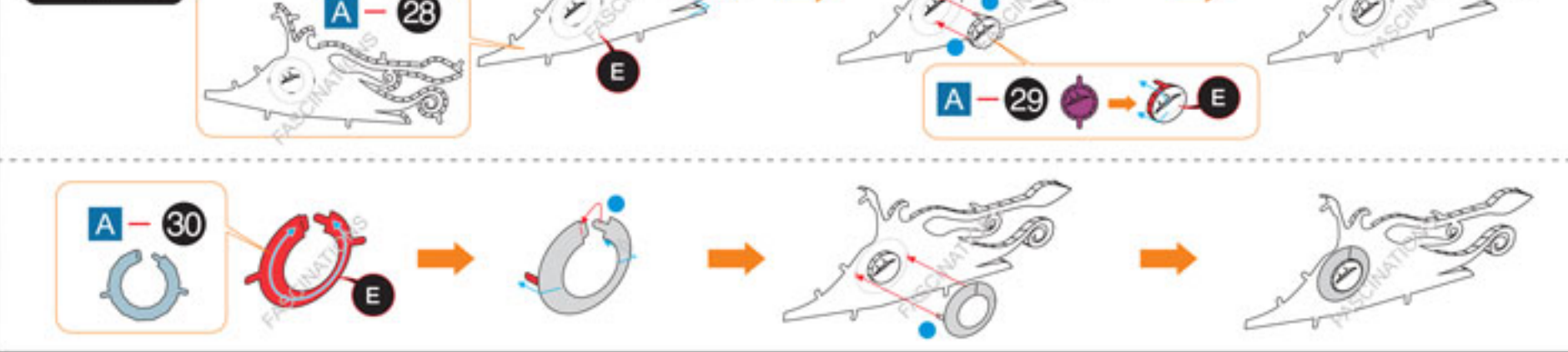

### Step 5

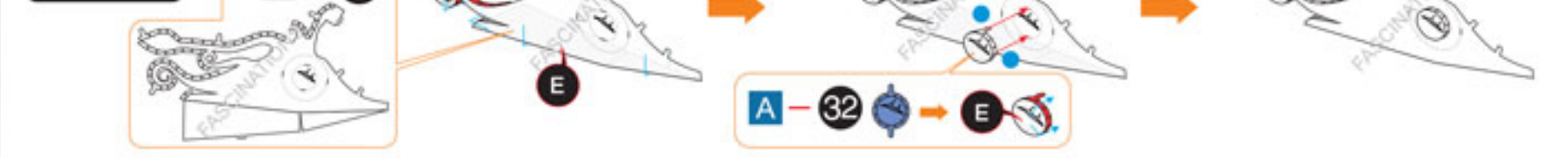





### Step 6

