

HEXBUG[®]

VEX[®]
ROBOTICS

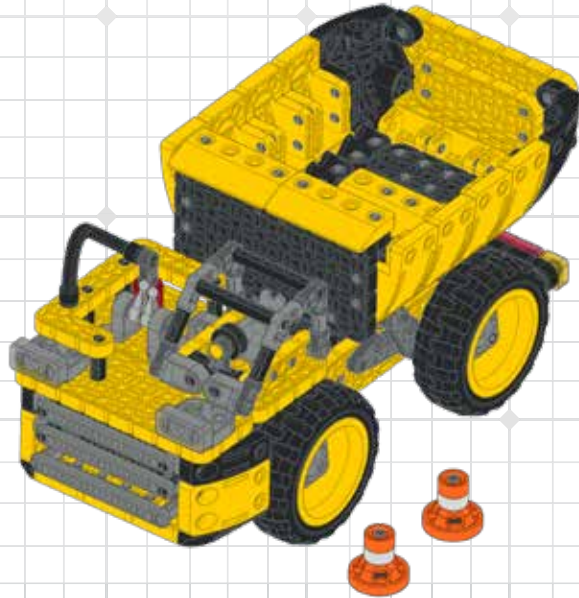

DUMP TRUCK[™]

PARENT/GUARDIAN • PARENT/TUTEUR • PADRE/GUARDIÁN • RODZIC/OPIEKUN • VANHEMPI /HUOLTAJA • FÖRÄLDER / MÅLSMAN

Part Size • Taille de la pièce • Tamaño de la pieza •
Teilegröße • Dimensione parte • Wielkośc części • Osan
koko • Delstorlek • Delstørrelse • Del Størrelse • 零件尺寸

Quantity • Quantité •
Cantidad • Menge •
Quantità • Ilość •
Määrä • Mängd •
Antall • Antal •
數量

1x

228-4133-004

1x5

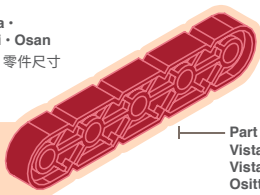

Part View • Vue de la pièce •
Vista de la pieza • Teilansicht •
Vista parte • Widok części •
Osittainen näkymä • Del bild •
Delvisning • Delvisning •
零件圖示

Part Number • Numéro de pièce • Número de
la pieza • Teilenummer • Numero di parte •
Numer części • Osannumero • Artikelnummer
• Delnummer • Del Nummer • 零件編號

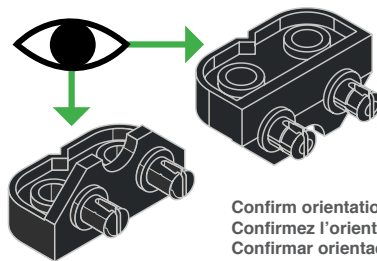

Confirm orientation
Confirmez l'orientation
Confirmar orientación
Ausrichtung prüfen
Confirmare l'orientamento
Potwierdź orientację
Vahvista suunta
Bekräfta riktning
Bekreft retning
Sørg for, at de vender rigtigt
確定零件安裝方向

Alert Alerte Alerta Warnung Attenzione Ostrzeżenie Varoitus Varning Varsle Alarm 警告	Correct Correcte Correcto Richtig Corretto Prawidłowo Varoitus Rätt Riktig Korrekt 正確	Incorrect Incorrecte Incorrecto Falsch Non corretto Nieprawidłowo Väärä Fel Feil Forkert 錯誤	Flip Retourner Voltear Umdrehen Capovolgere Przerzuc Käännä Vänd Vend Flip 翻轉	Rotate Liquider Faire tourner Girar Drehen Ruotare Obróć Pyöritä Rotera Roter Drej 旋轉	Wind up Liquider Dar cuerda Aufziehen Arrotola Nawin Kierrä Drag upp Trek opp Træk op 捲起	Notice Avis Aviso Hinweis Fare attenzione Zwróć uwagę Huomaa OBS Merknad Bemærk 注意

Sticker Autocollant Calcomania Aufkleber Etichetta Naklejka Tarra Klistermärke Klistrermerke Klistermærke 貼紙	Zoom view Zoom Vista con zoom Zoom-Ansicht Vista con zoom Powiększenie Suurennettu näkymä Zoom vy Zoom-visning Zoom visning 放大查看	Alternate view Autre vue Vista alternativa Andere ansicht Vista alternativa Widok alternatywny Vaihtoehtoinen näkymä Alternativ vy Alternativ visning Alternativ vinkel 多視角查看	Connectors Connecteurs Conectores Anschlüsse Connettori Złącza Liittimet Anslutningar Kontaktpunkter Stik 連接頭	Electrical Électrique Eléctrico Elektrik Elettrico Elektryczne Sähköinen Elektrisk Elektrisk Elektrisk 電子件	Motion Déplacement Movimiento Bewegung Movimento Ruch Liike Rörelse Bevegelse Bevægelse 運動件	Structure Structure Estructura Struktur Struttura Konstrukcja Rakenne Struktur Struktur Bygning 結構件

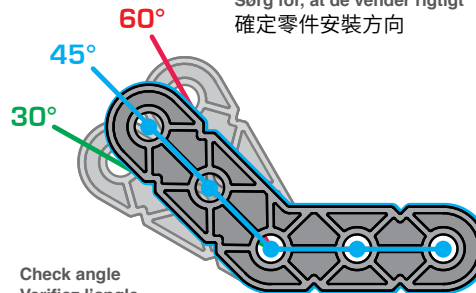

Check angle
Verifiez l'angle
Verificación de ángulo
Winkel prüfen
Controllare l'angolazione
Sprawdź kąt
Tarkista kulma
Kontrollera vinkel
Sjekk vinkel
Tjek vinklen
檢查零件角度

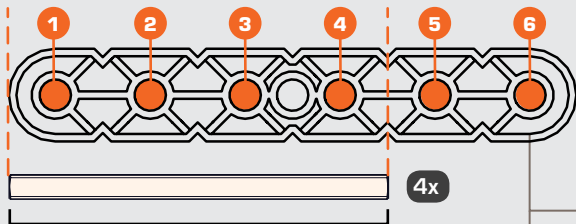

1x6

Count before you connect
 Compter avant de connecter
 Contar antes de conectar
 Erst zählen, dann verbinden
 Contare i pezzi prima di collegarli
 Policz, zanim połączysz
 Laske ennen kuin yhdistät
 Räkna innan du sätter ihop
 Tell før du kobler til
 Tæl, før du samler
 核對零件型號及規格

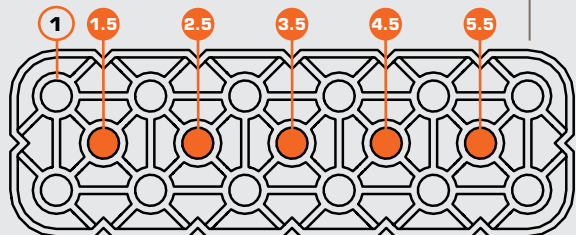

2x6

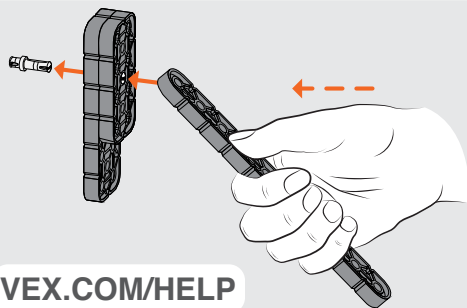

Remove connectors
 Retirez connecteurs
 Retirar conectores
 Verbindungsstücke entfernen
 Rimuovere i connettori
 Wyjmij łączniki
 Poista liittimet
 Ta bort kopplingar
 Fjern kontaktpunkter
 Fjern koblingsdelene
 移除連接頭

VEX.COM/HELP

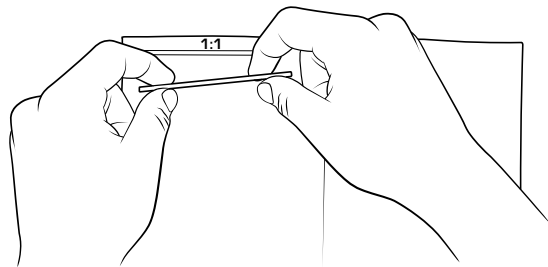

1:1

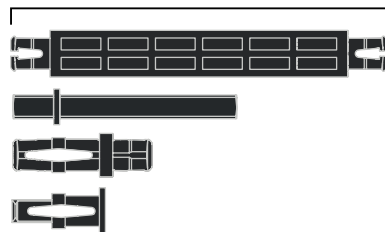

Check pieces against actual size in manual
 Vérifiez les pièces contre leurs tailles réelles dans le manuel
 Verificar partes contra tamaño real en el manual
 Bauteile mit der originalgröße in der Anleitung vergleichen
 Controllare le dimensioni dei pezzi nel manuale rispetto alla grandezza naturale
 Sprawdź elementy względem rzeczywistego rozmiaru w instrukcji
 Tarkista kappaleiden todellinen koko vertaamalla ohjekirjaan
 Kontrollera bitarnas storlek mot storleken i handboken
 Sjekk delene mot faktisk størrelse i manualen
 Tjek, om brikkerne passer med den rigtige størrelse i manualen
 檢查零件的實際尺寸並與說明書上的尺寸比對

PARTS/ LES PIÈCES/ PARTES/ BAUTEILE/ PARTI/ CZESCI/ OSAT/ DELAR / DELER/ BYGGEDELE/ 零件清單

1x **1x2**
228-3201-001



1x **1x7**
228-3201-006



1x **1x8**
228-3201-007



1x **2x4**
228-3201-019

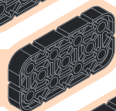

1x **2x10**
228-3201-025

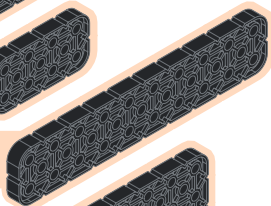

1x **3x6**
228-3201-034

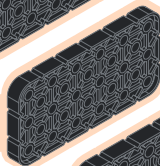

2x **4x4**
228-3201-040

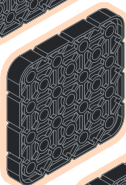

2x **4x6**
228-3201-042

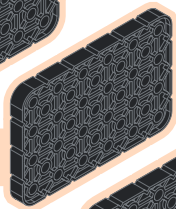

1x **4x8**
228-3201-043

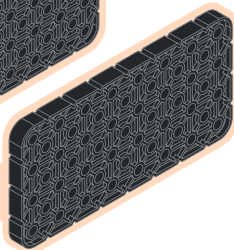

1x **3x4**
228-3201-032

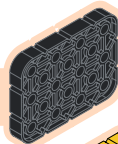

1x **3x5 90°**
228-3449-150

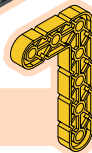

5x **1x4**
228-3449-003

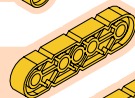

1x **2x5**
228-3449-020

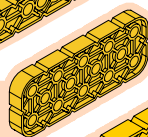

3x **2x7**
228-3449-022

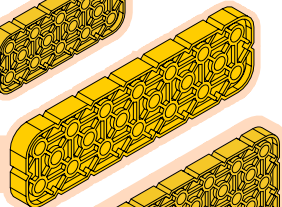

1x **3x8**
228-3449-035

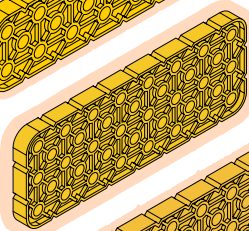

1x **4x8**
228-3449-043

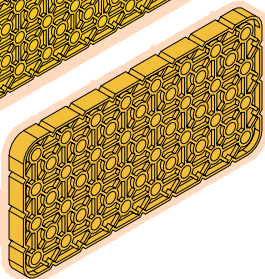

2x **1x1**
228-3943-154



2x **1x1**
228-3446-154



3x **1x1**
228-4133-154



2x **2x2**
228-3446-1925



4x **2x2**
228-3944-1925

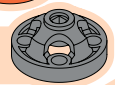

4x
228-3616-1924

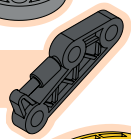

8x
228-3449-2109

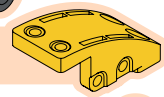

2x
228-4146-510

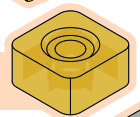

2x
228-3945-511

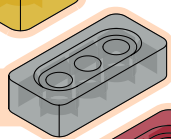

2x
228-4143-511

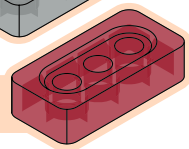

2x
228-5573-1909

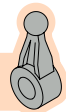

1x
228-3944-1859

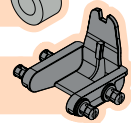

2x
228-3201-2100



1x
228-3201-2120



1x
228-3201-2121



1x
228-3201-2134

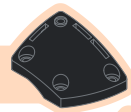

1x
228-3201-2135



3x
228-3449-1704

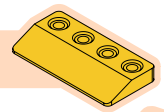

8x
228-3449-2101

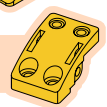

PARTS/ LES PIÈCES/ PARTES/ BAUTEILE/ PARTI/ CZESCI/ OSAT/ DELAR / DELER/ BYGGEDELE/ 零件清單

8X **0.25x**

228-3201-114



121X **1x1**

228-3616-060



2X **2x2**

228-3616-062

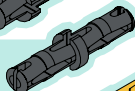

1X **0x2**

228-3449-084

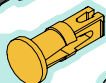

6X **0x2**

228-5573-086

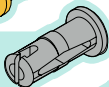

3X **0x3**

228-3616-087

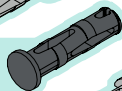

1X **3x3**

228-5573-089

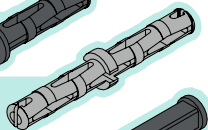

4X **2x**

228-3616-080

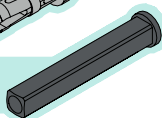

4X

228-3201-109



4X **0.25x**

228-3201-063



4X **0.5x**

228-3944-064

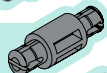

7X **1x**

228-3201-065

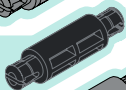

5X **1.5x**

228-3944-066

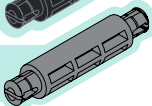

6X

228-3201-129



2X

228-3944-130



6X

228-3944-133

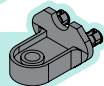

12X

228-3201-128



2X

228-3201-132



2X

228-3944-131

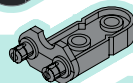

6X

228-3944-135

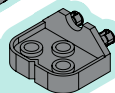

2X

228-3201-134

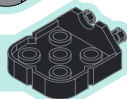

2X

228-3201-067

2x

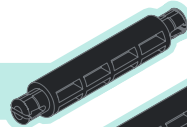

2X

228-3201-069

3x

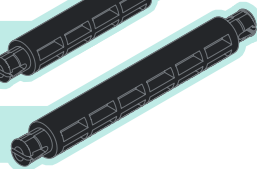

4X 228-3616-178



2X 228-3944-175



6X 228-3616-172



7X 228-3944-127



1X 228-3944-1255

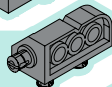

1X 228-3201-1251



1X 228-3201-220



2X 228-3201-368



1X 228-3201-137

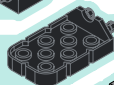

1X 228-3944-1254

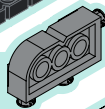

1X **3x** 228-2500-119

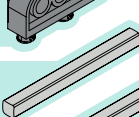

1X **8x** 228-2500-124

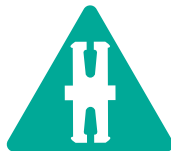
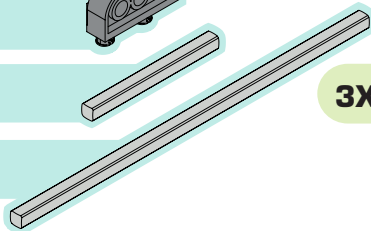

4x 228-3944-112



8X 228-2500-143



1x 228-3201-163



4X 228-3201-1956



1X **6x** 228-3201-1934

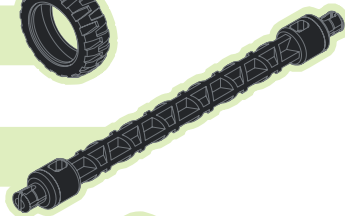

4X 228-3449-1953

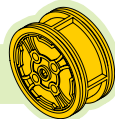

3X 228-3944-1472

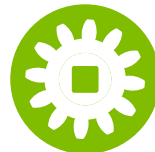
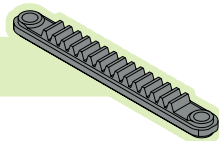

3x4



x1

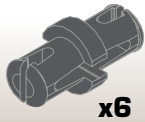

x6



1x1

1:1



x2

4x4



x1

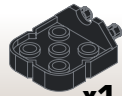

x1



x1



x1

2x

1:1

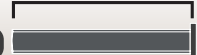

1

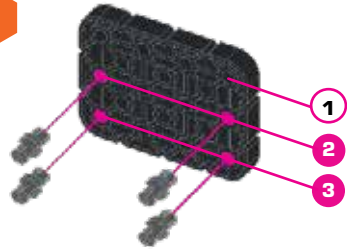

2

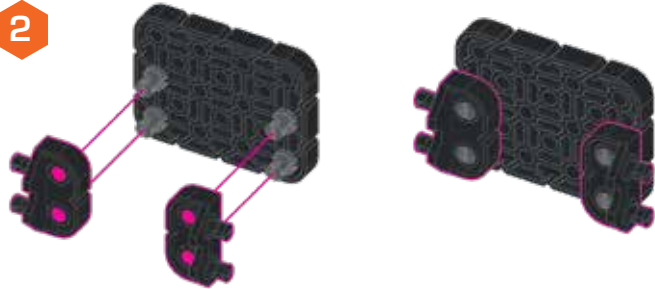

3

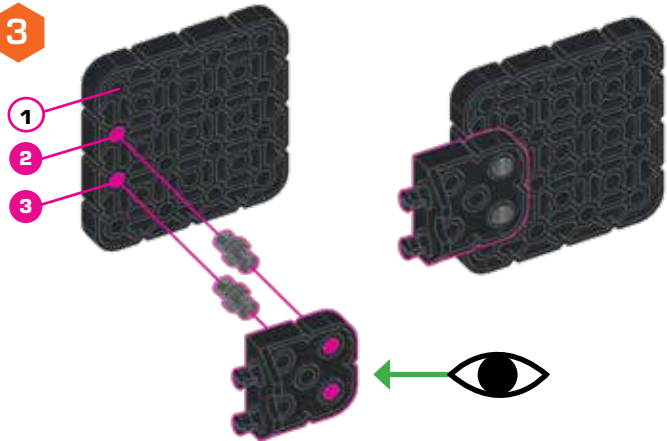

4

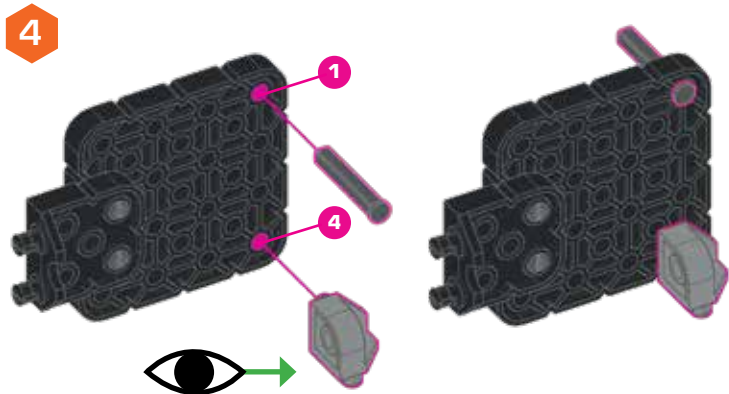

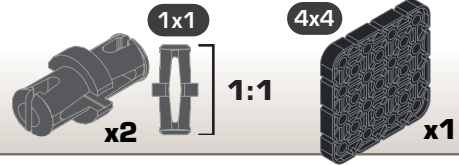
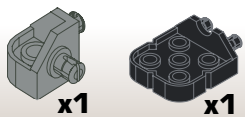
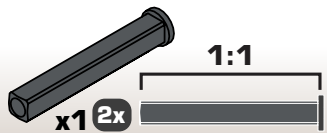

5

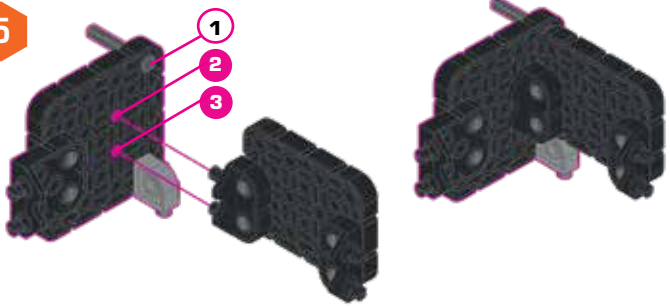

6

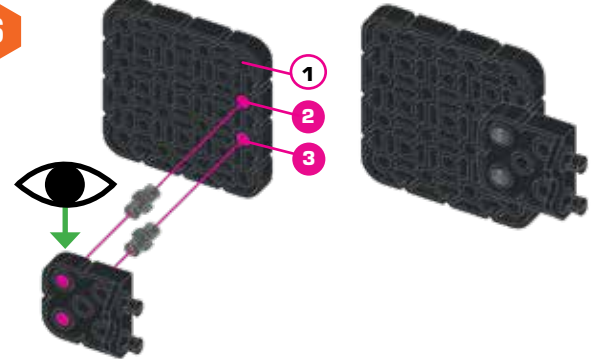

7

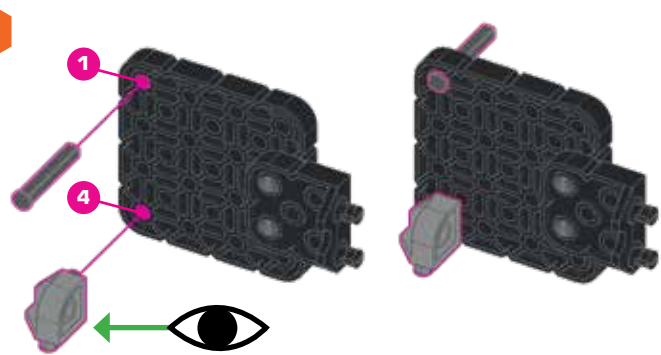

8

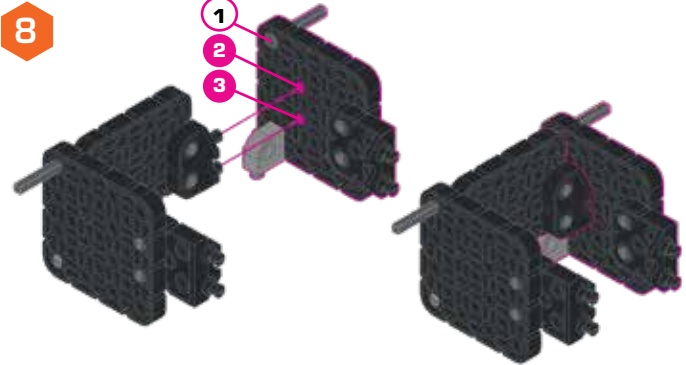

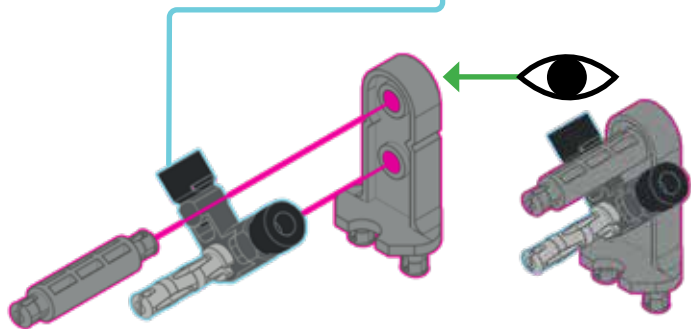
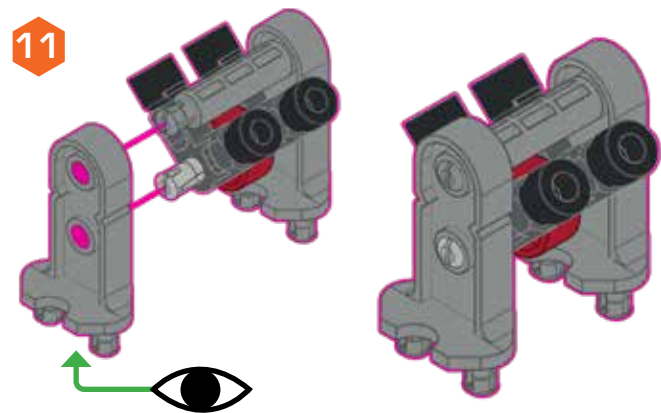
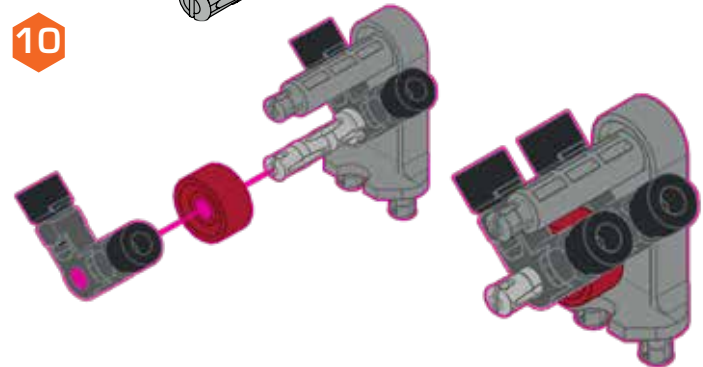
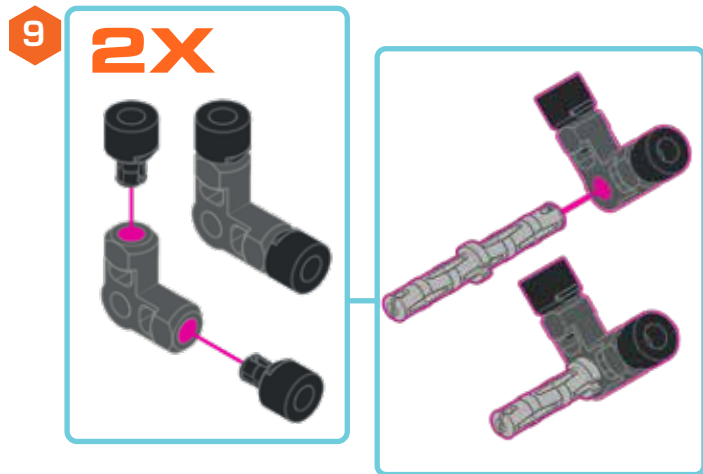
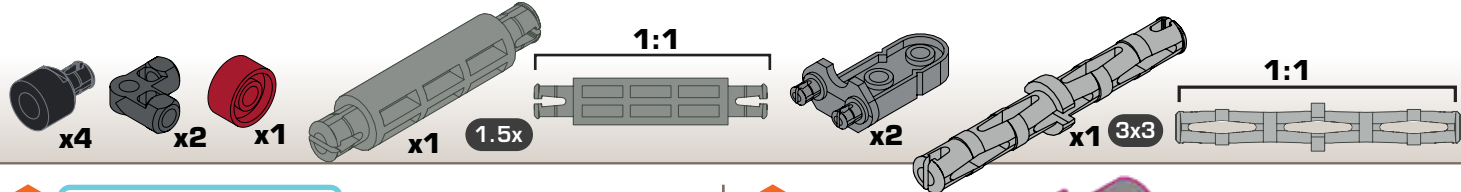

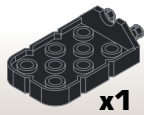

x1

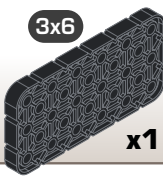

3x6

x1



x1



x2

12

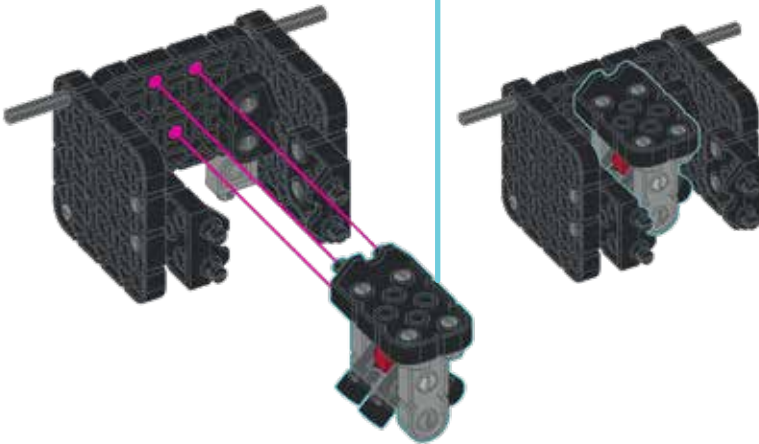
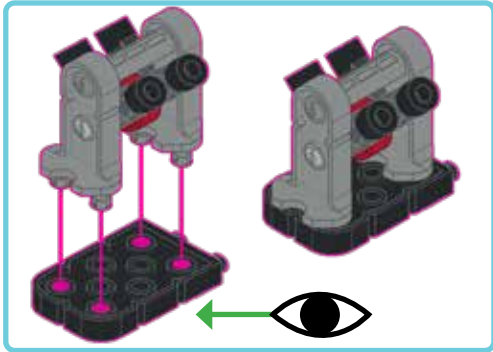

13

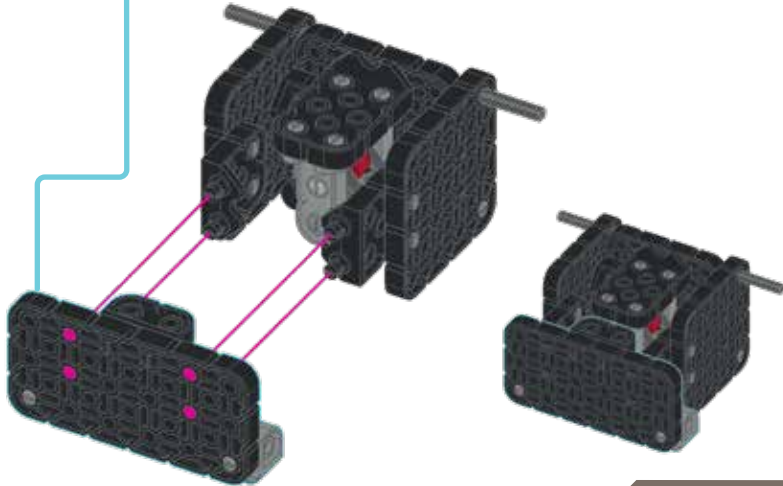
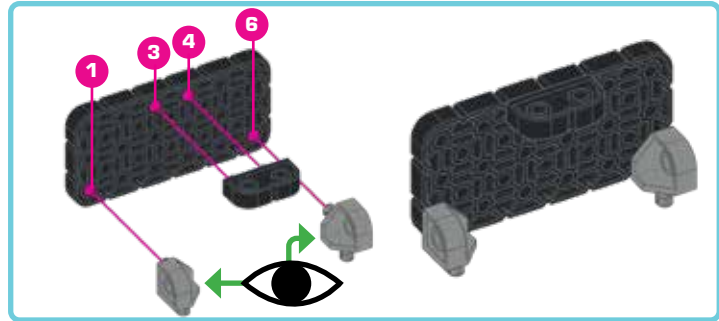

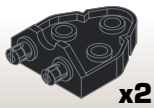

x2

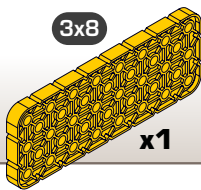

3x8

x1

14

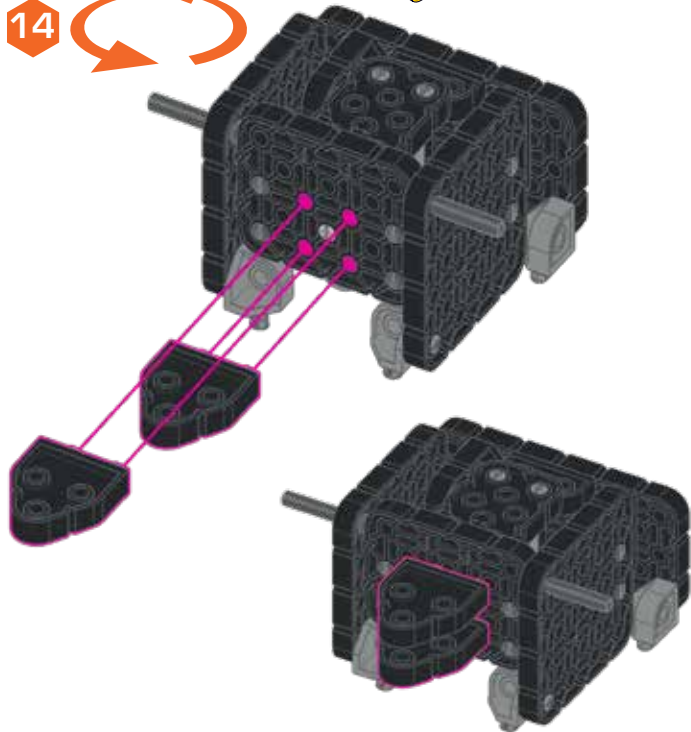

15

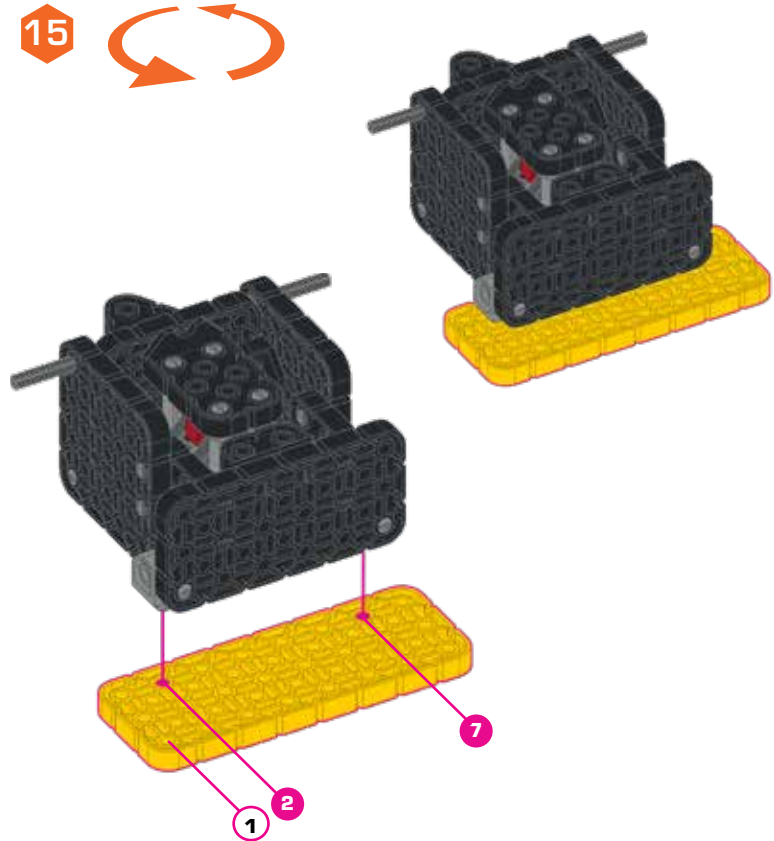

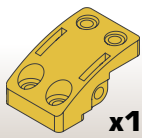

x1

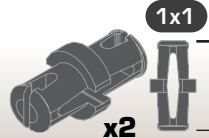

x2



1x1

1:1



x1

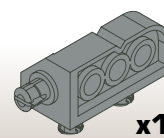

x1

16

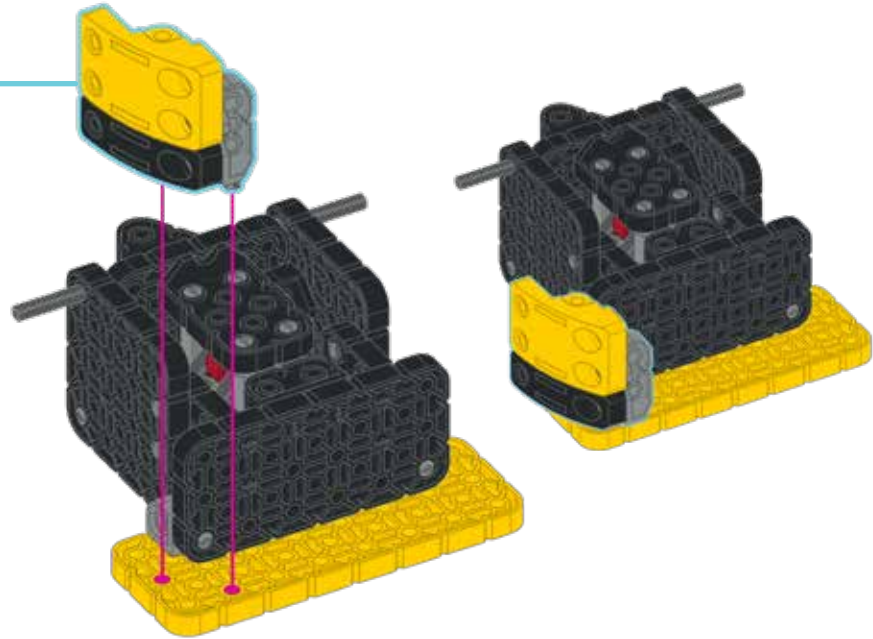
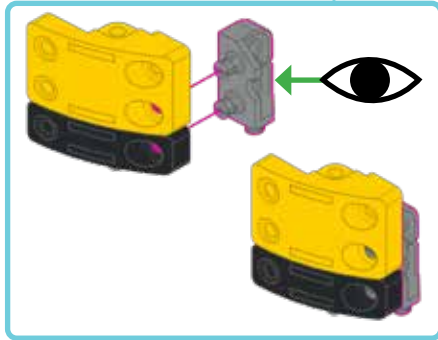
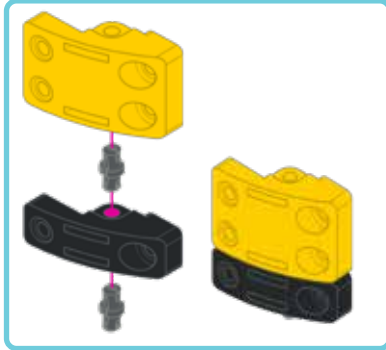

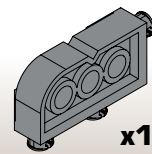
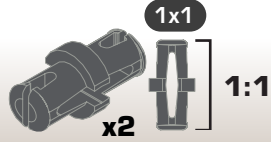
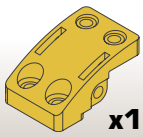

17

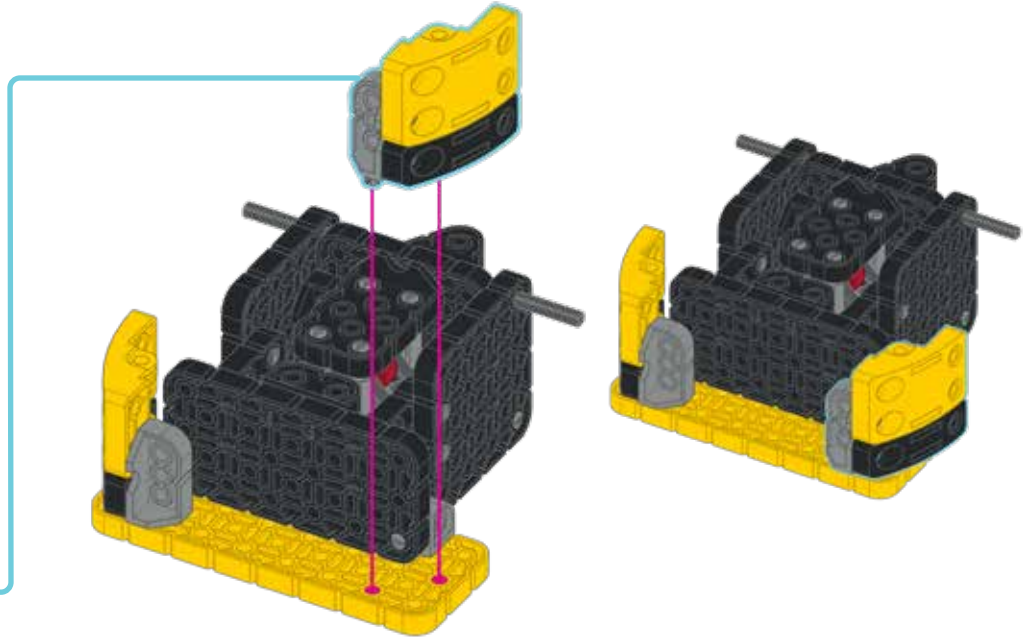
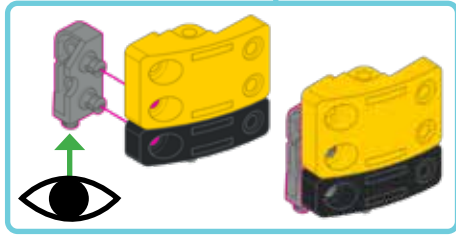
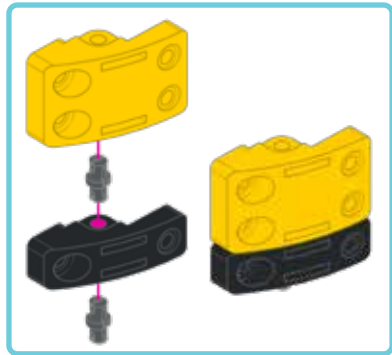

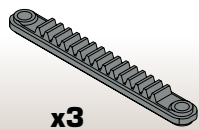

x3

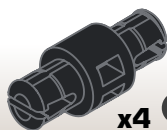

x4

0.25x



1:1

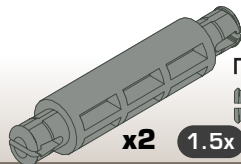

x2

1.5x



1:1

18

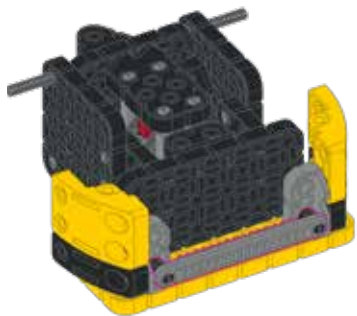
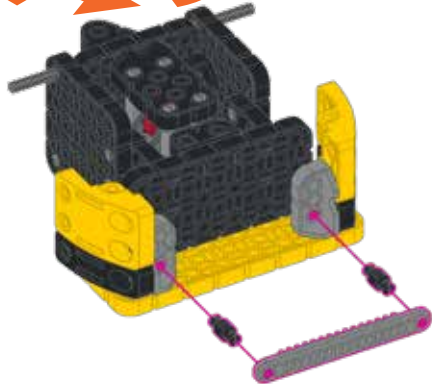

19

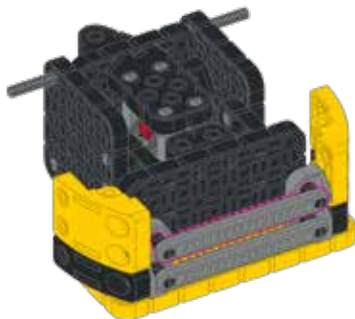
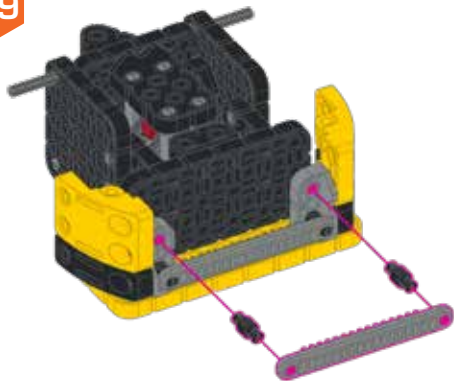

20

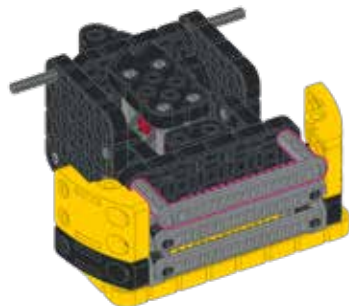
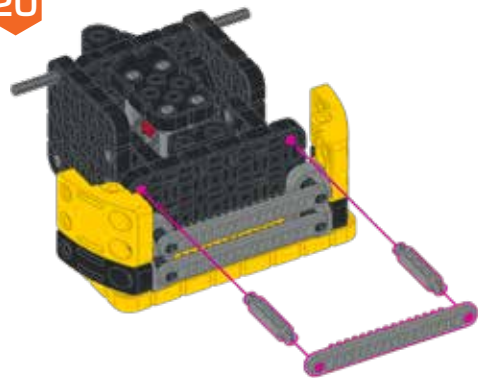

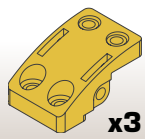

x3

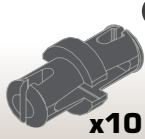

x10



1x1

1:1



x1



x1

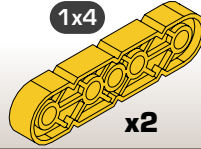

1x4

x2

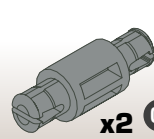

x2

0.5x



1:1

21

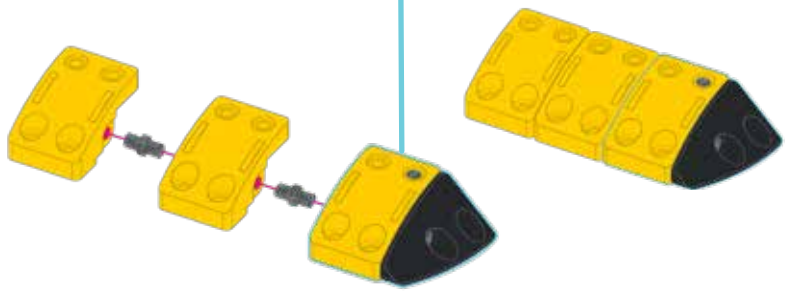
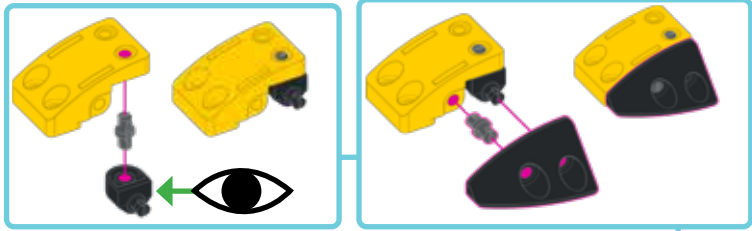

22

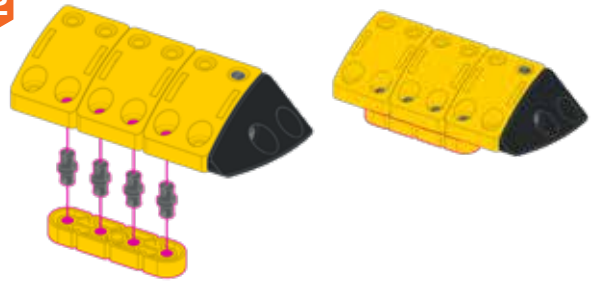

23

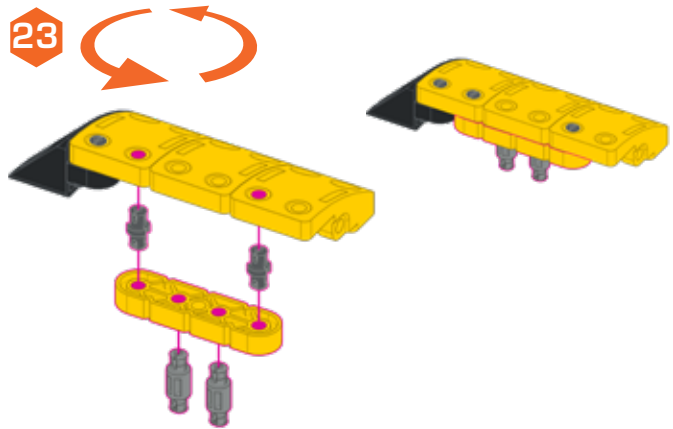

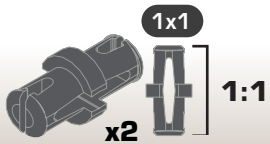

24

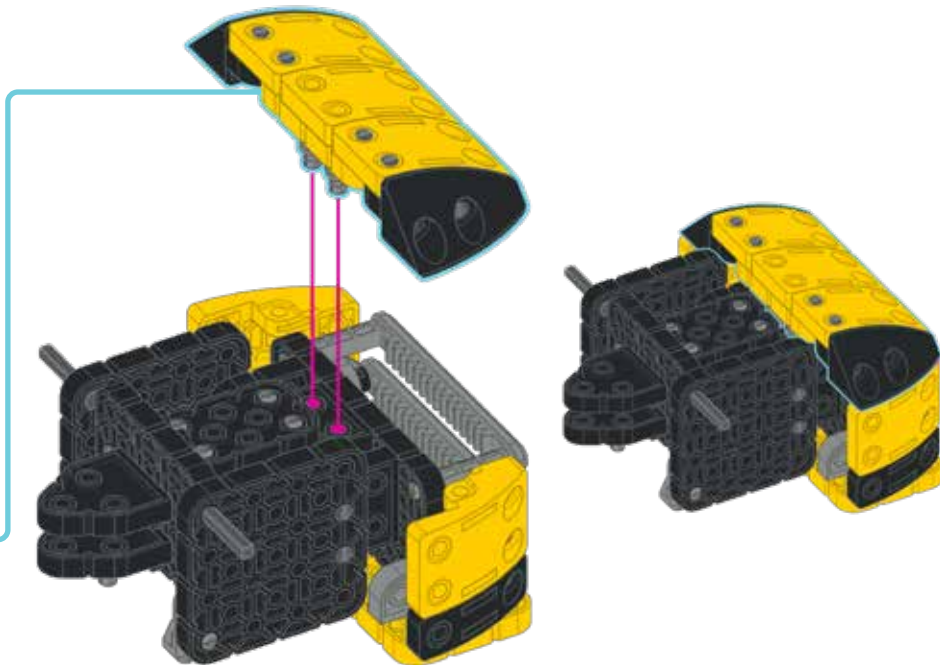
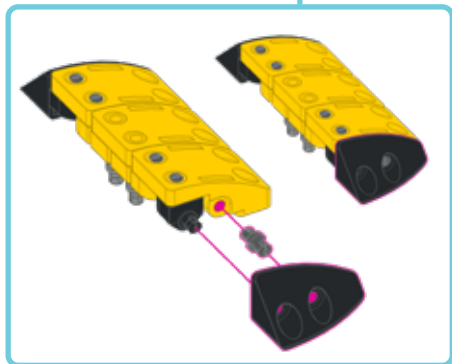
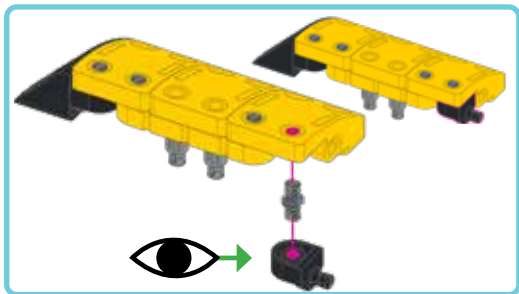

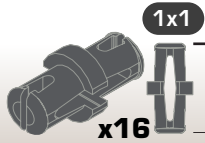
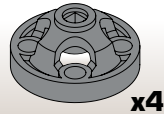
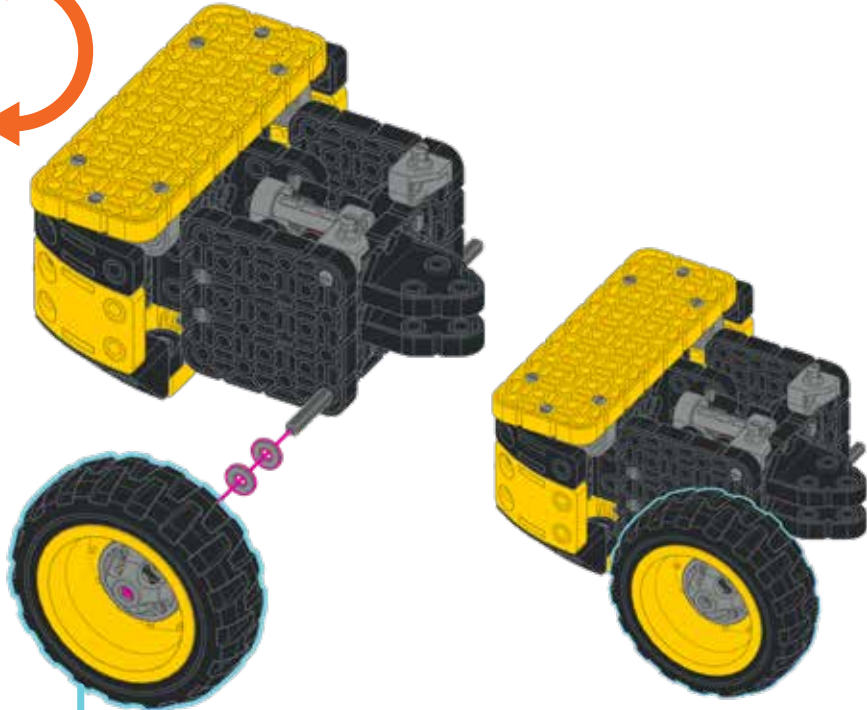
**1x1****1:1****25**



x2

4x8

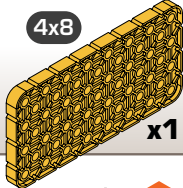

x1

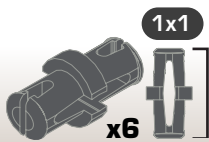

x6

1x1

1:1

26

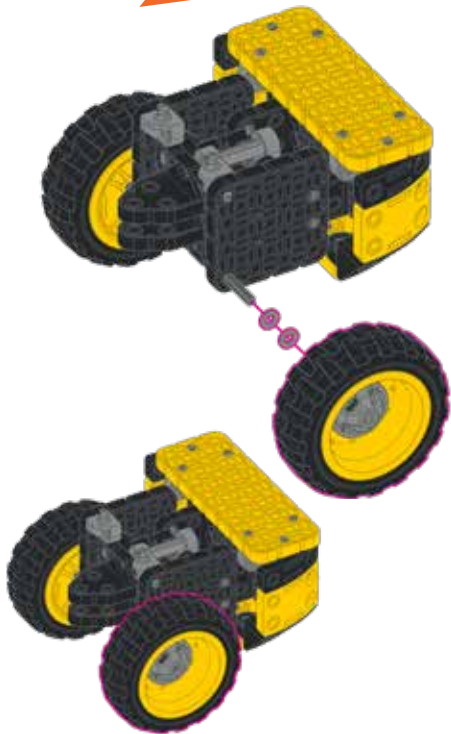

27

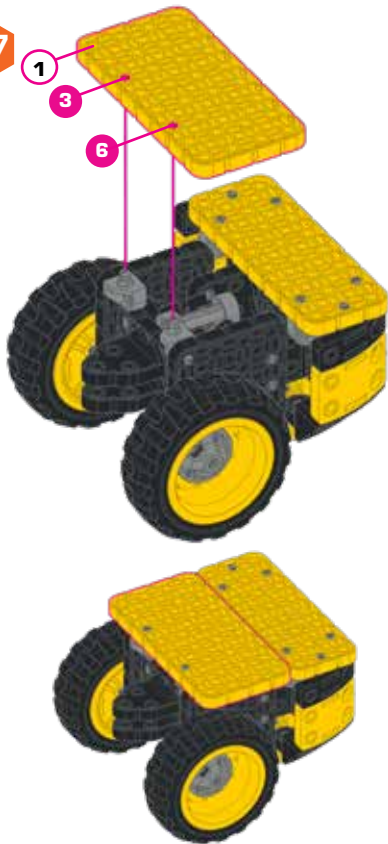

28

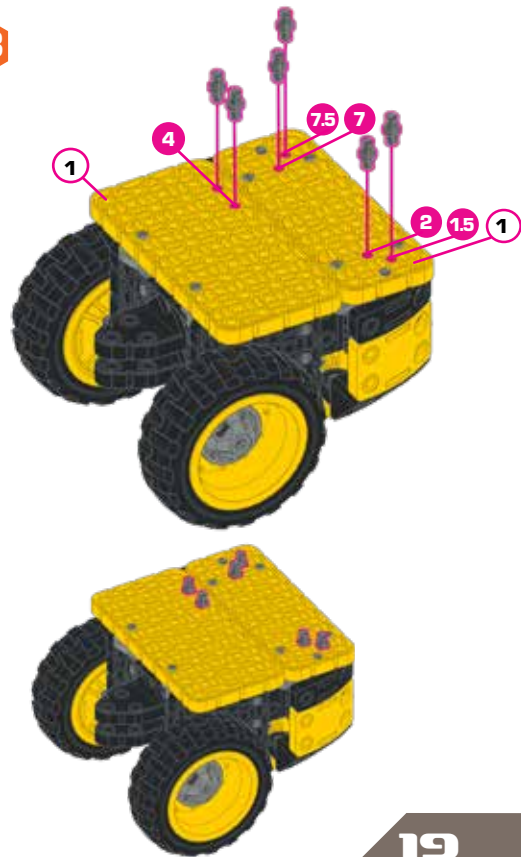

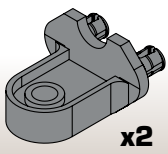

x2

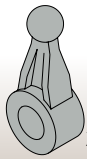

x2

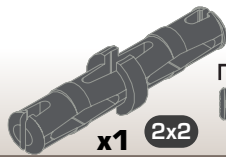

x1

2x2



1:1

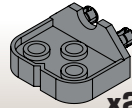

x2

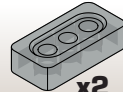

x2

29

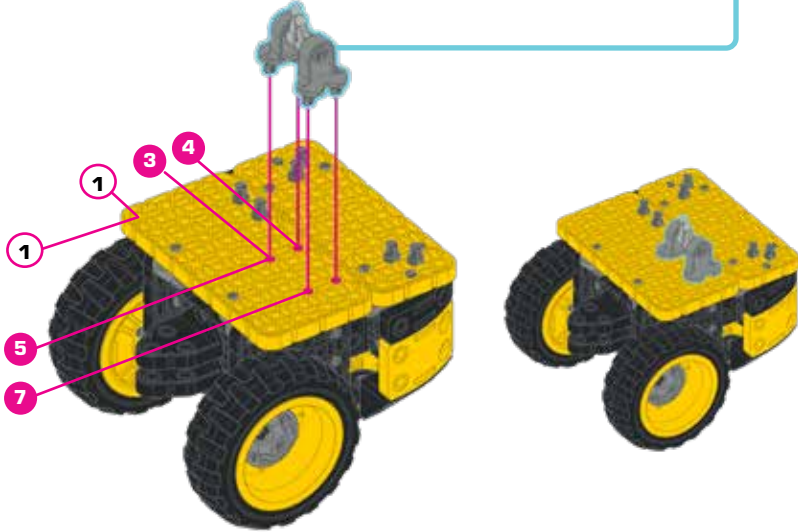
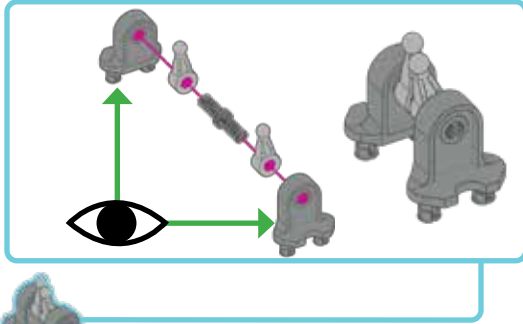

30

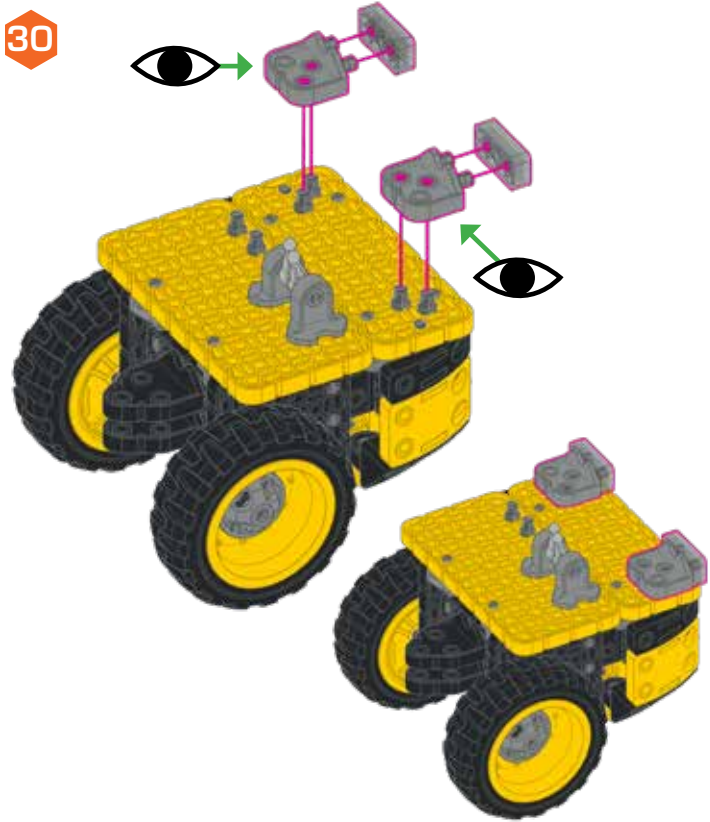

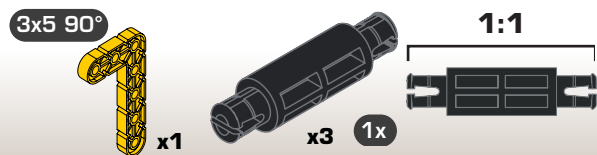
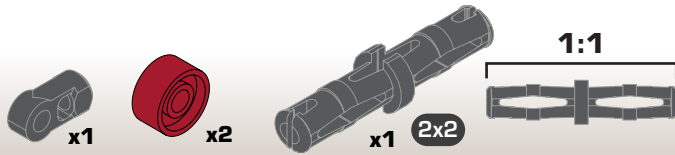

31

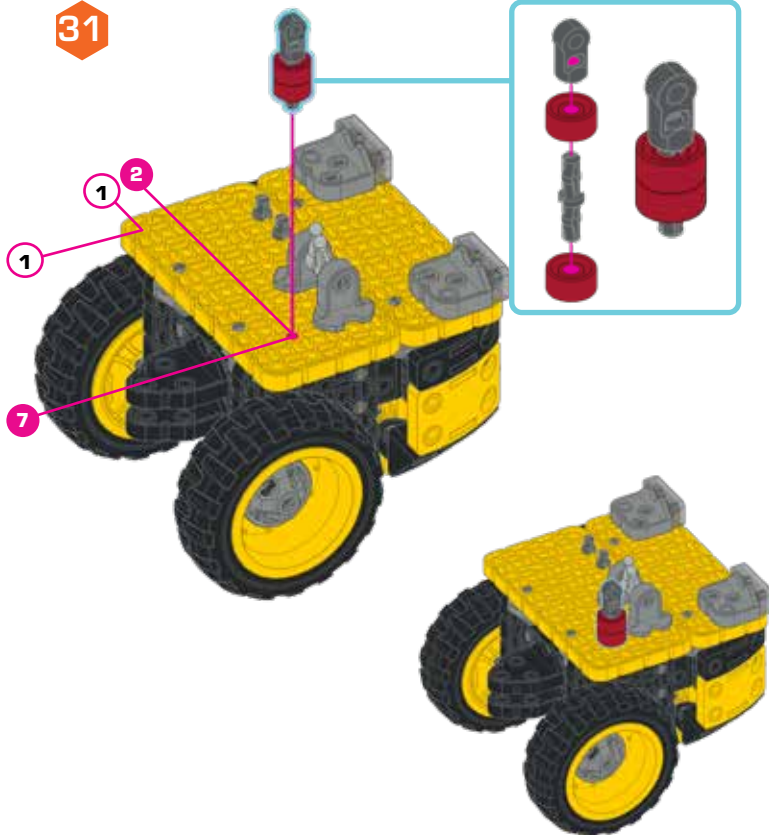

32



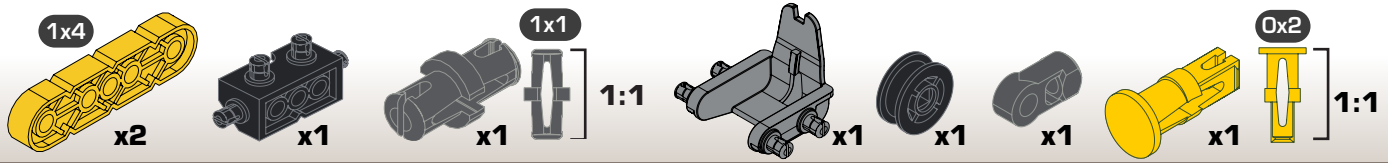

33

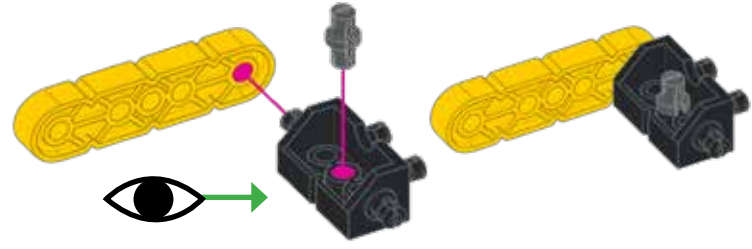

34

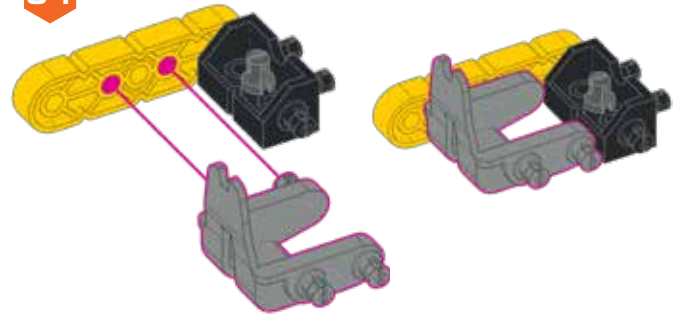

35

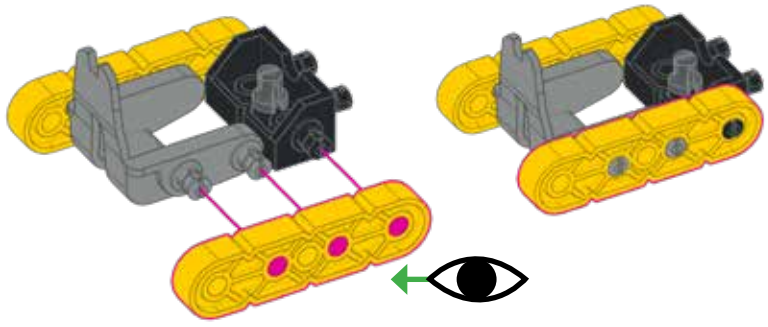

36

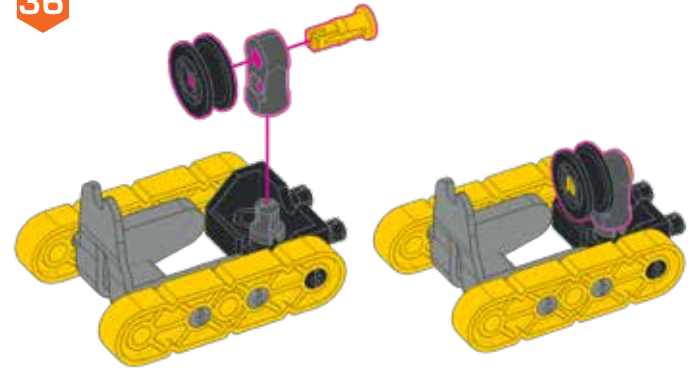

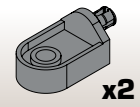
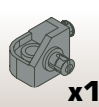
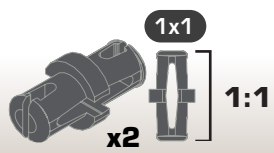

37

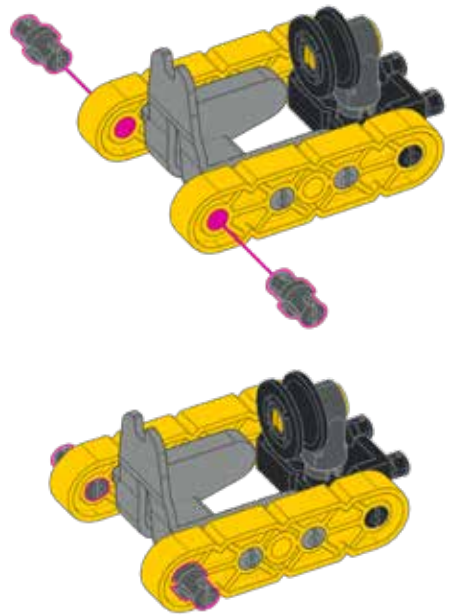

38

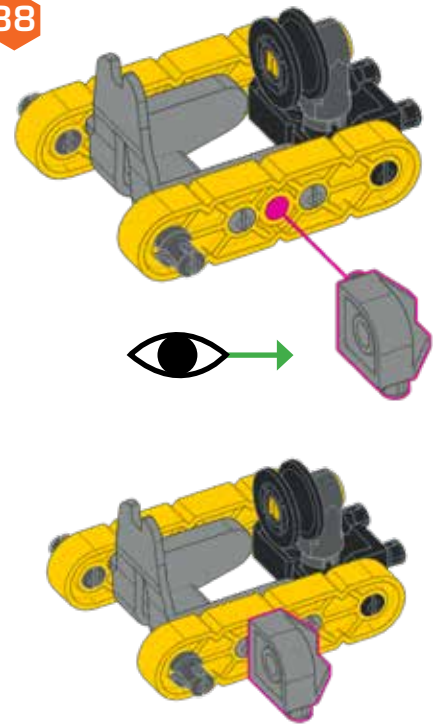

39

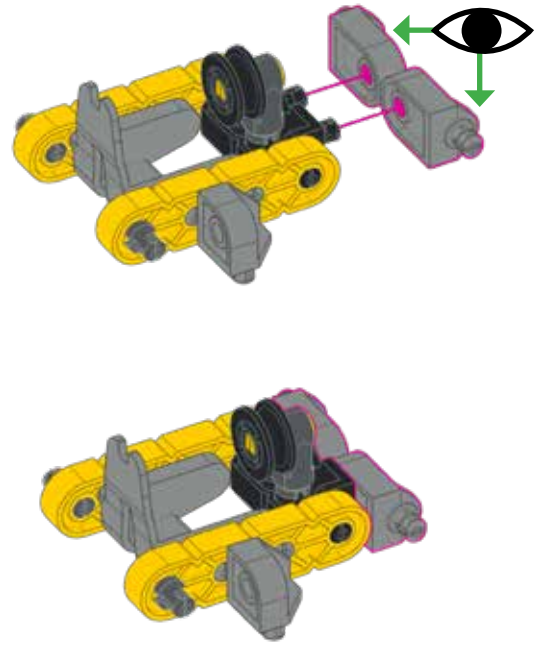

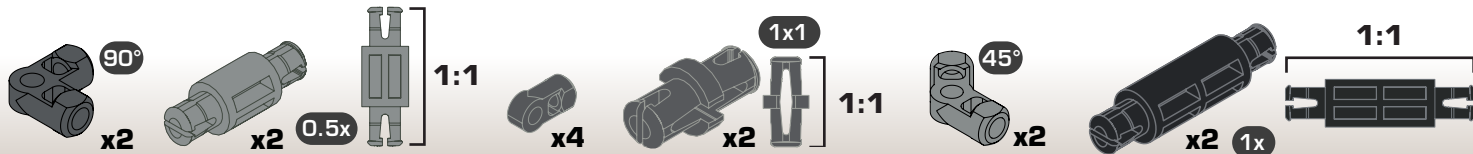

40

2X

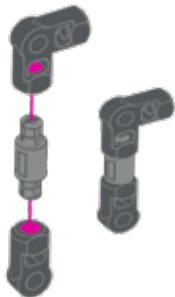

2X



2X

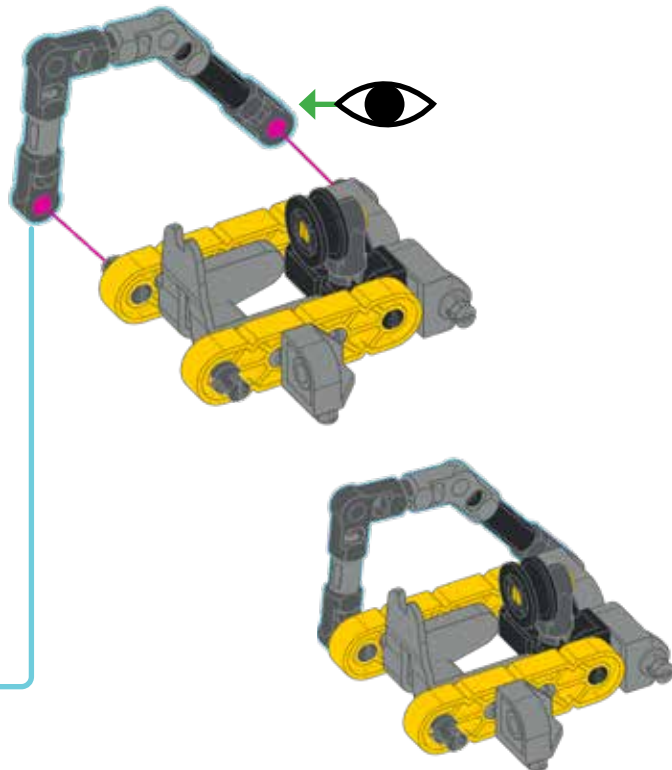



x2 3x

1:1



41

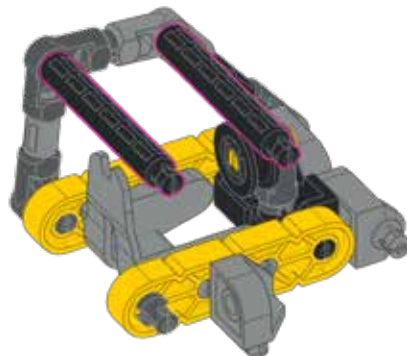
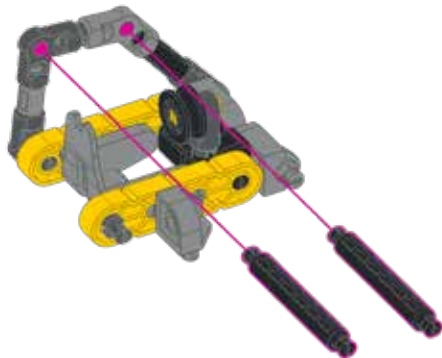

42

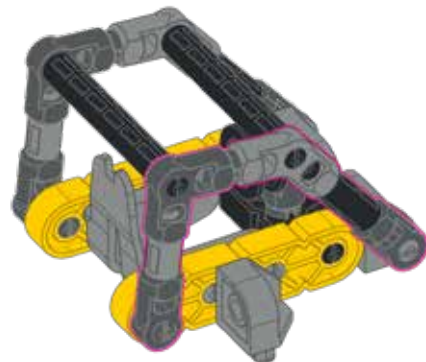
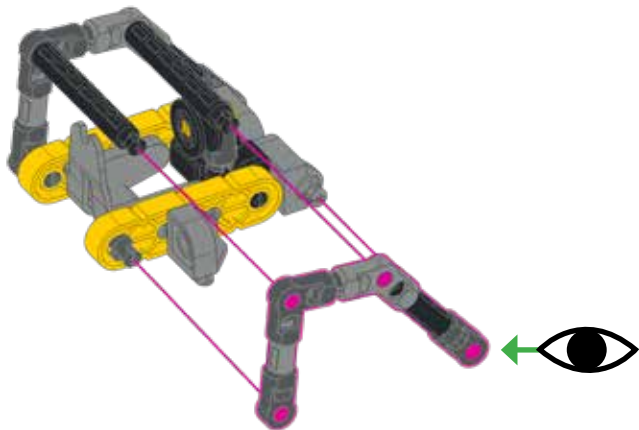

43

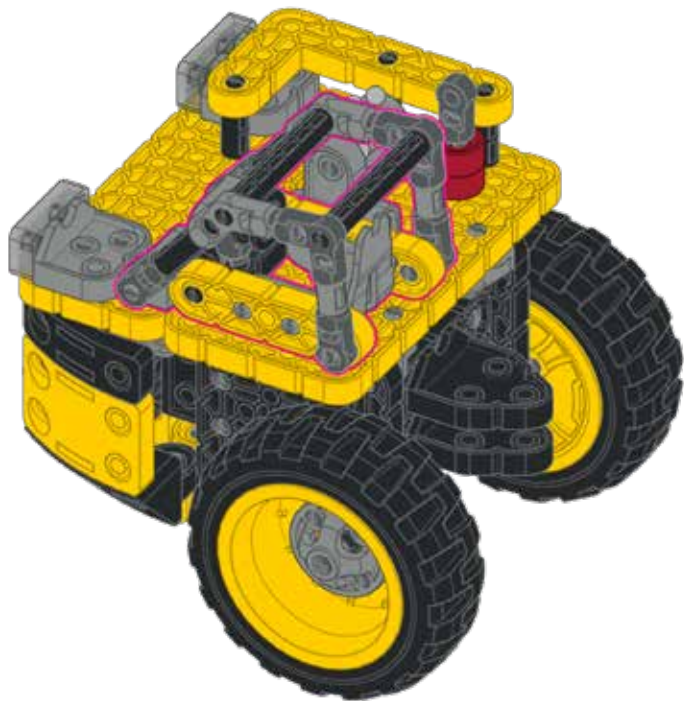
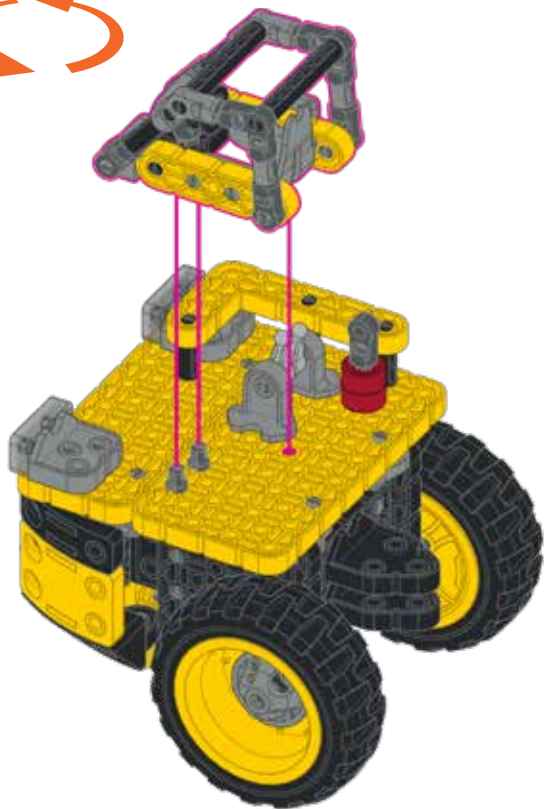

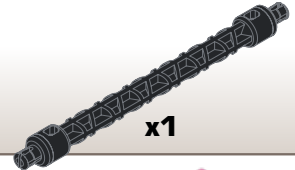
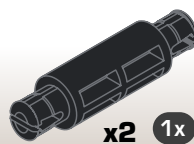
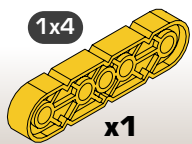

44

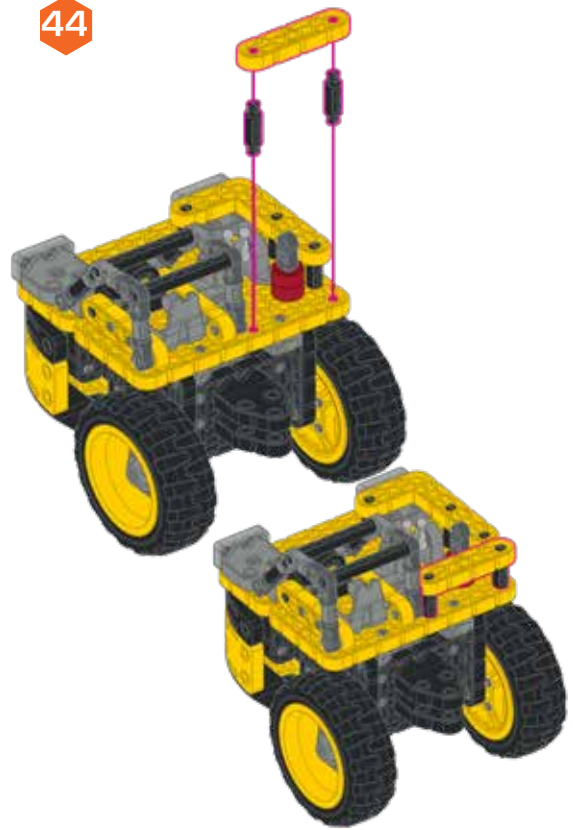

45



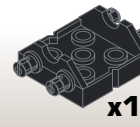
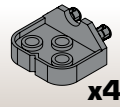
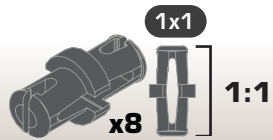
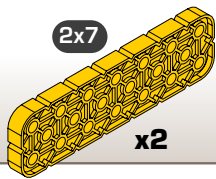

46

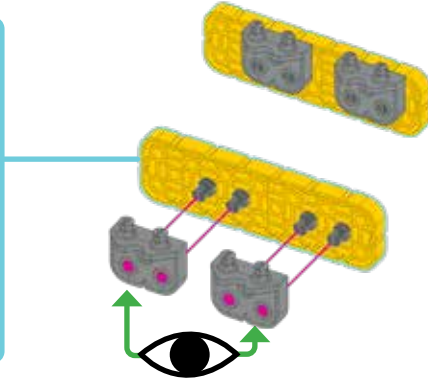
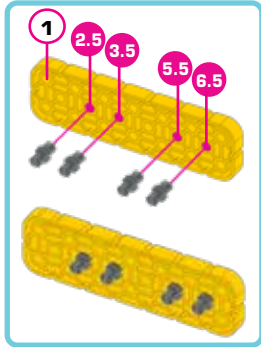

47

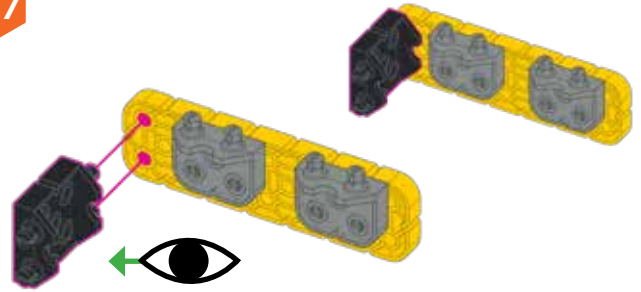

48

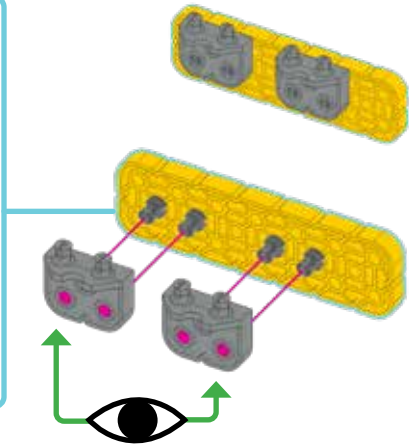
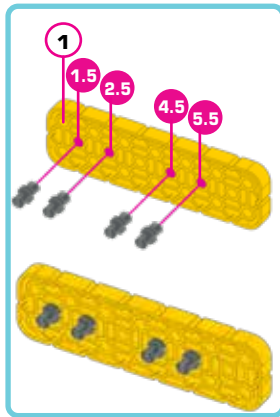

49

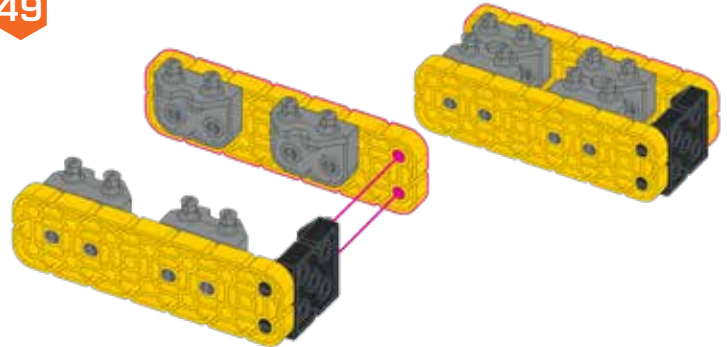

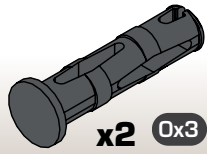

1:1

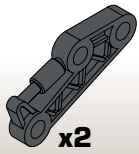

x2

2x10



x1

50

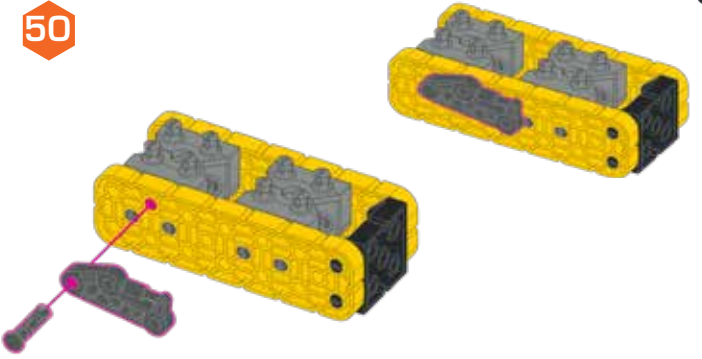

52

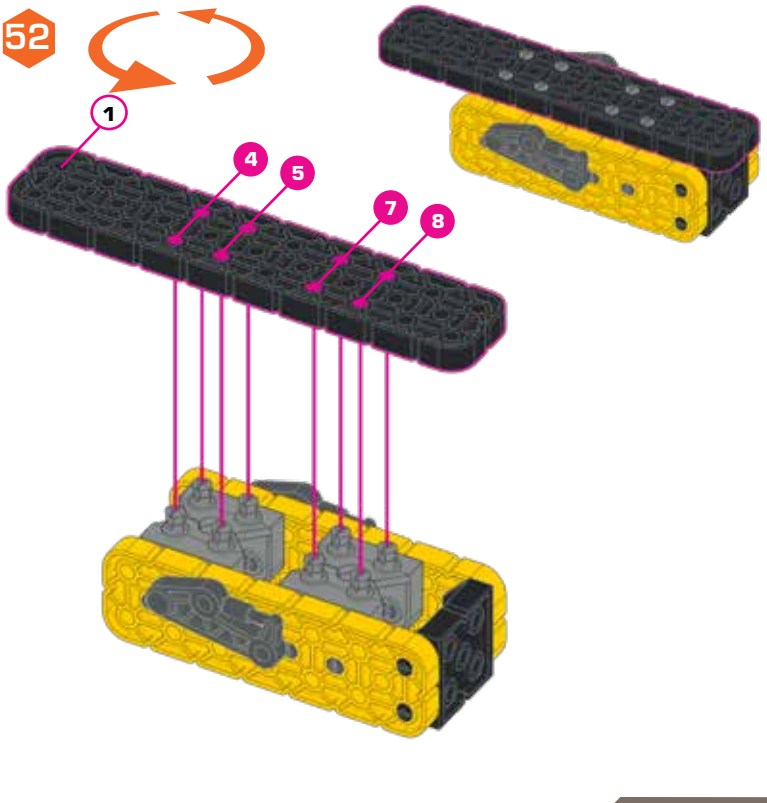

51

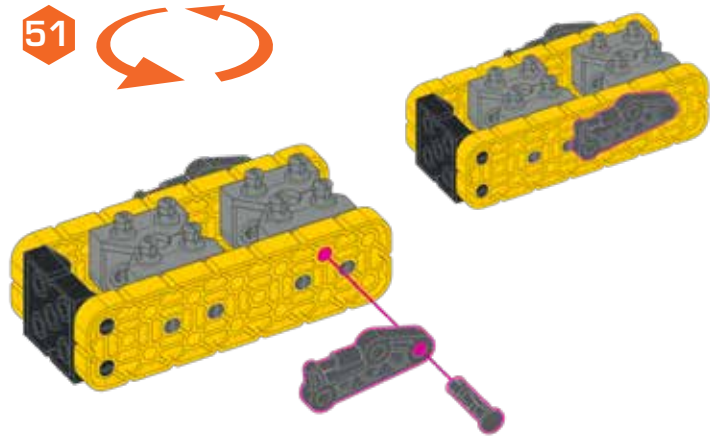

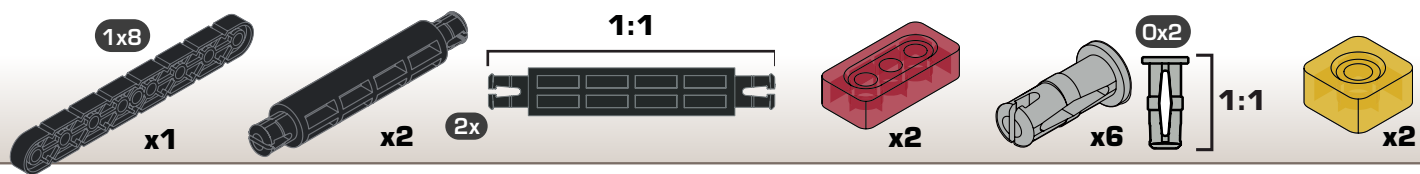

53

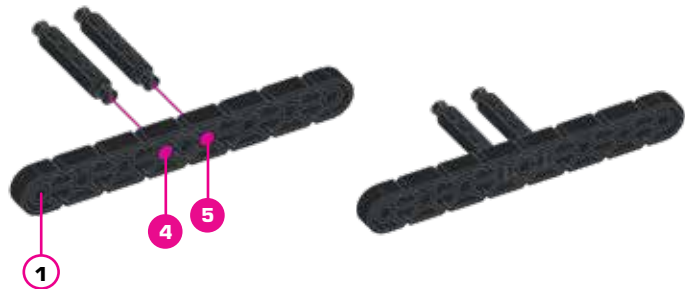

54

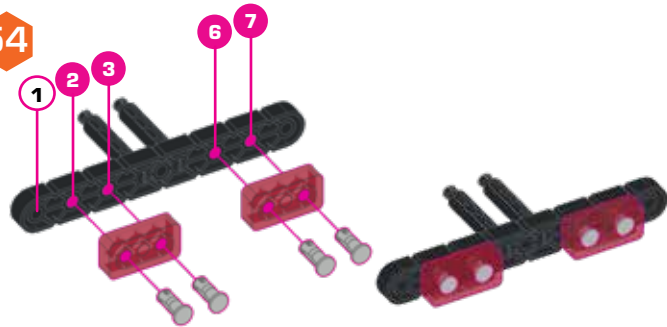

55

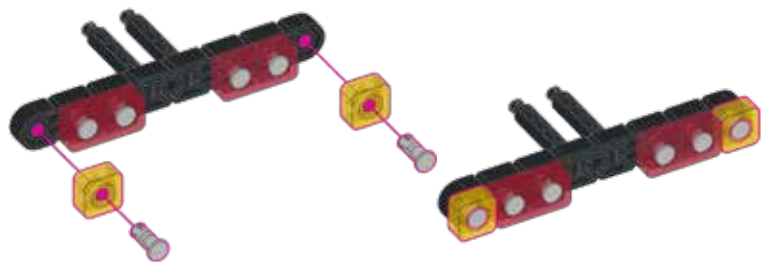

56

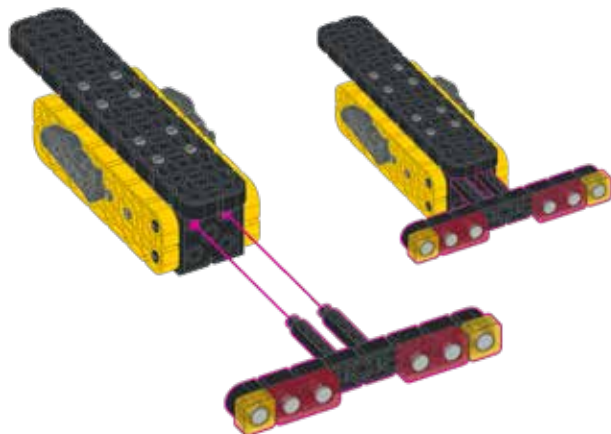

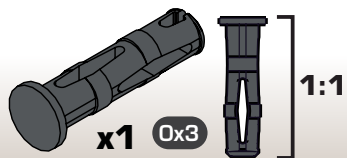

57



1x3



x1

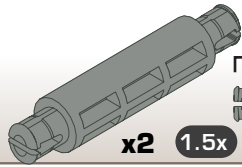

x2

1.5x

1:1



58



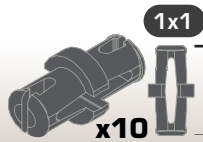

1:1

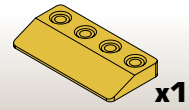

59

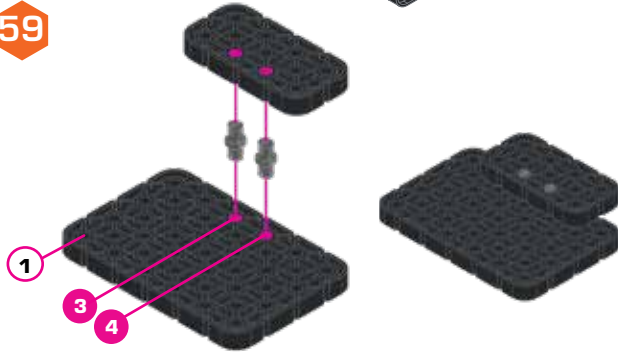

60

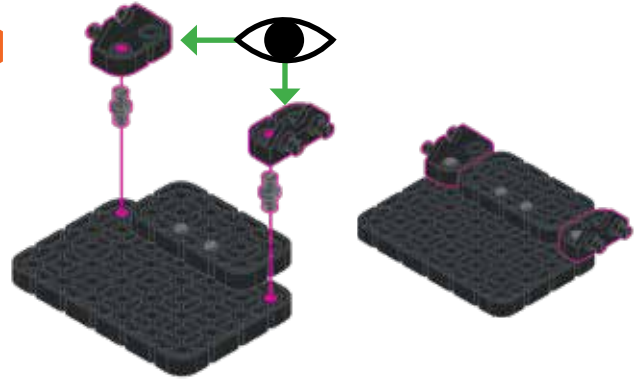

61

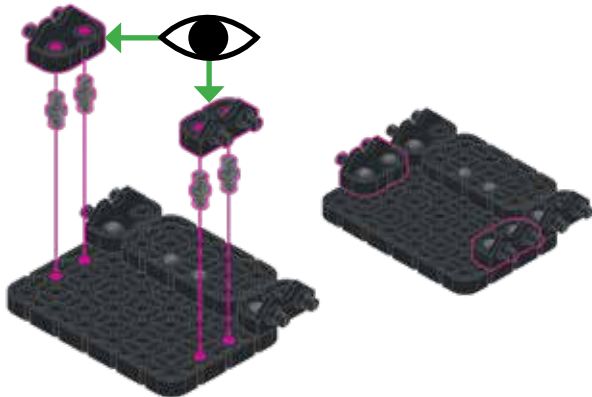

62

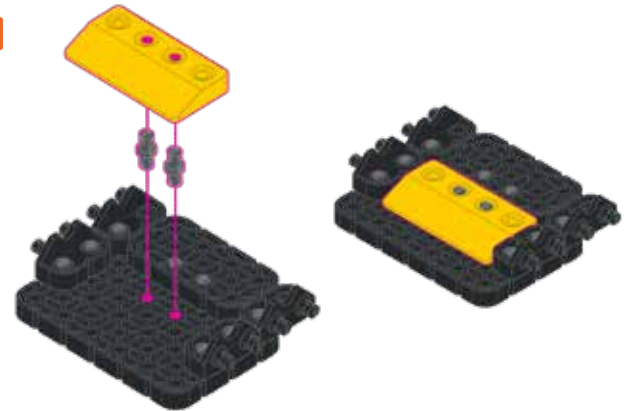

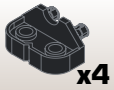

x4

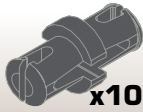

x10



1:1

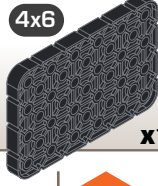

x1

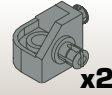

x2

63

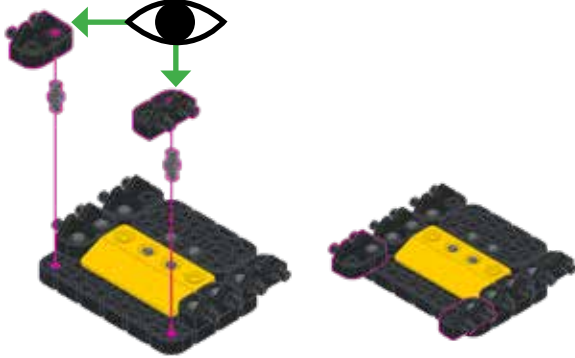

64



65

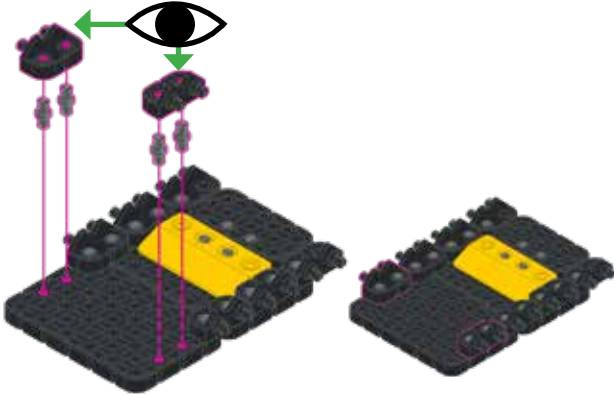

66

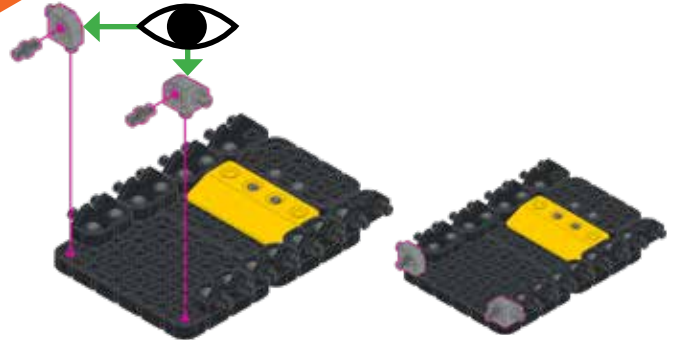

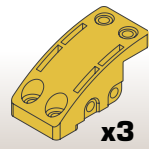
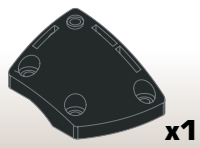
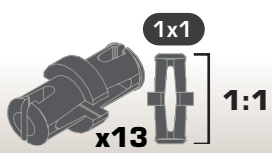

67

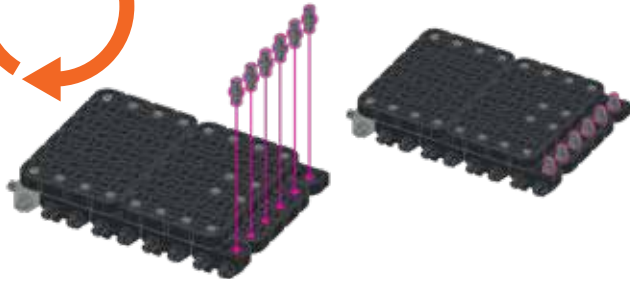

68

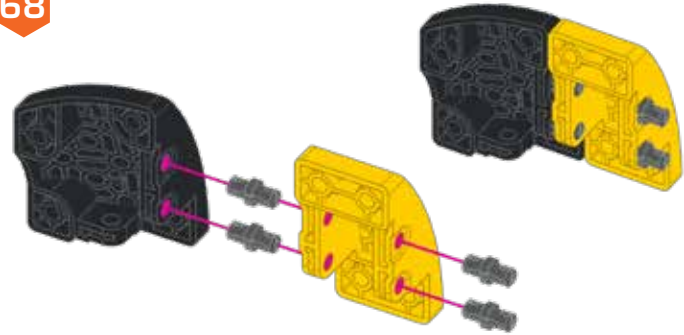

69

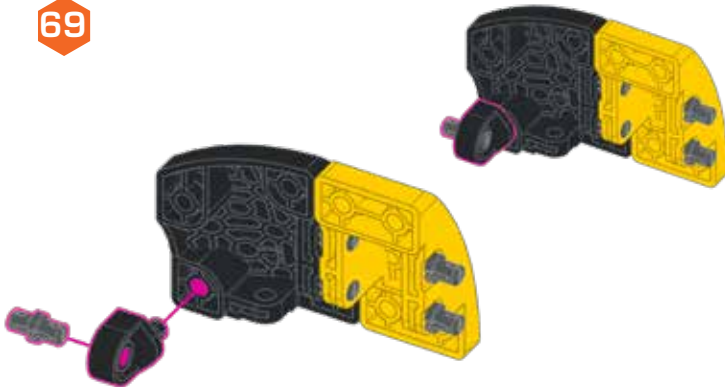

70

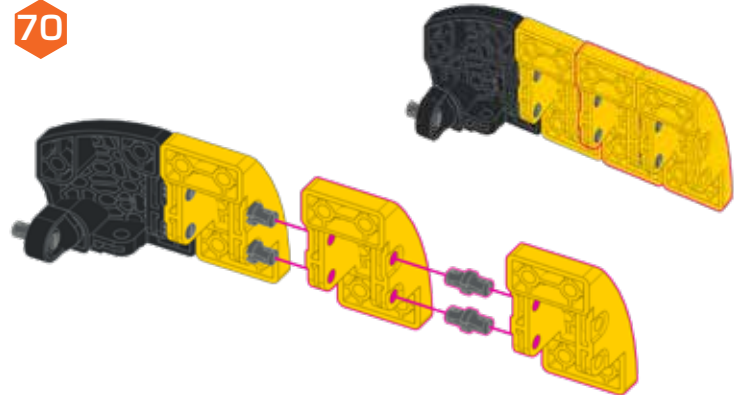

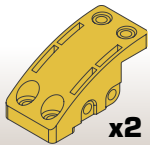

x2



x9



1x1

1:1



x1



x1

71

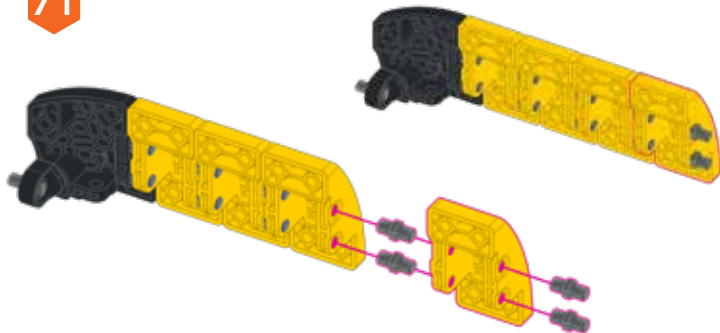

72

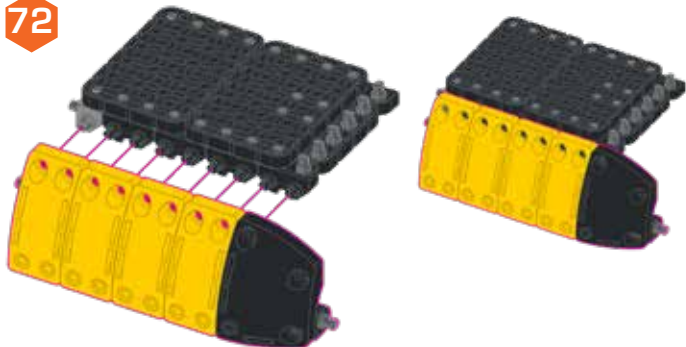

73

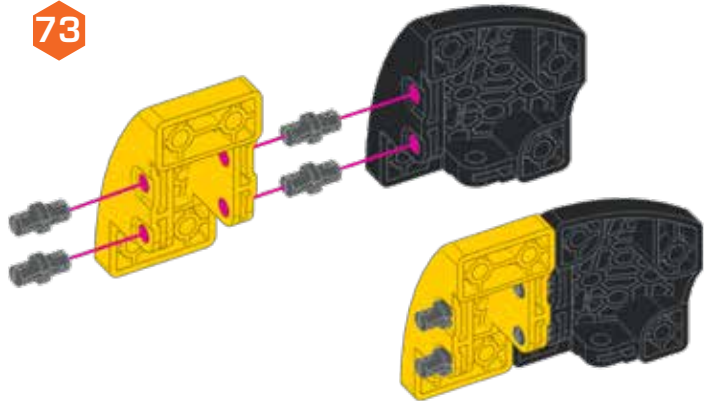

74

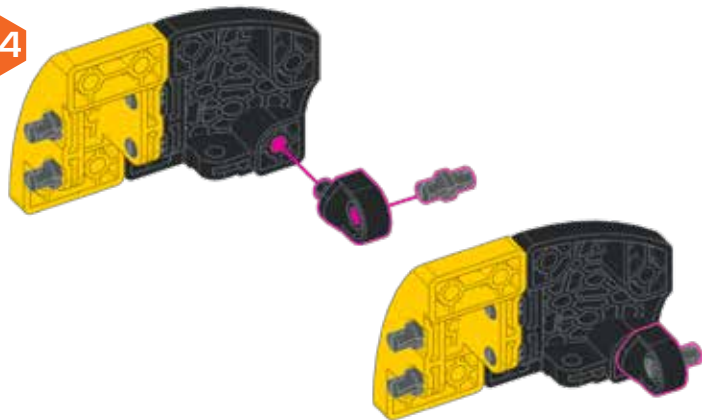

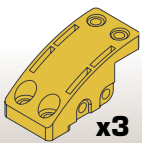

x3



x6



1x1

1:1

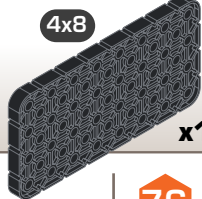

4x8

x1



x1



x2

75

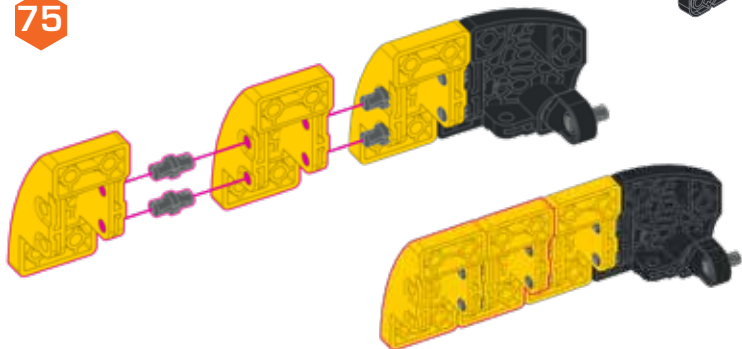

76

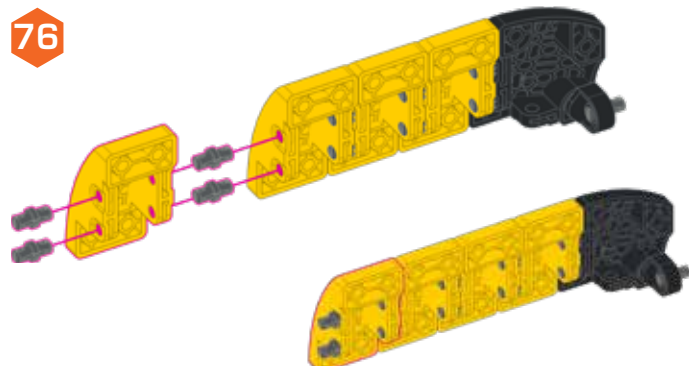

77

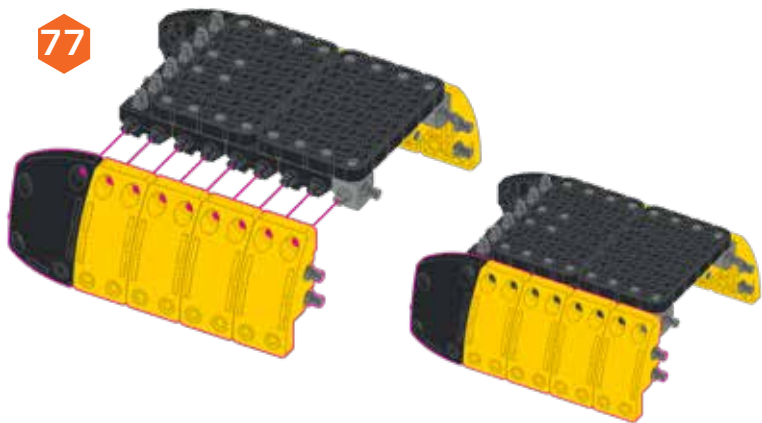

78

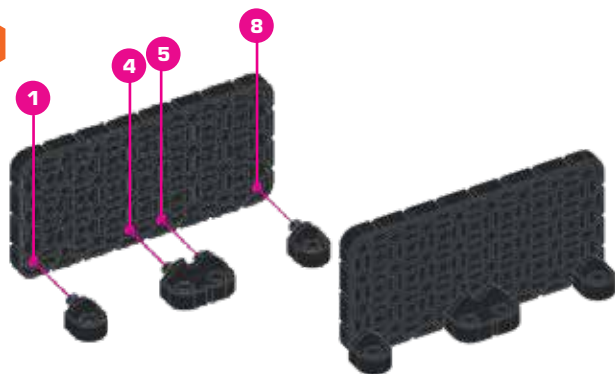

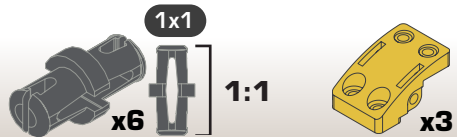

79

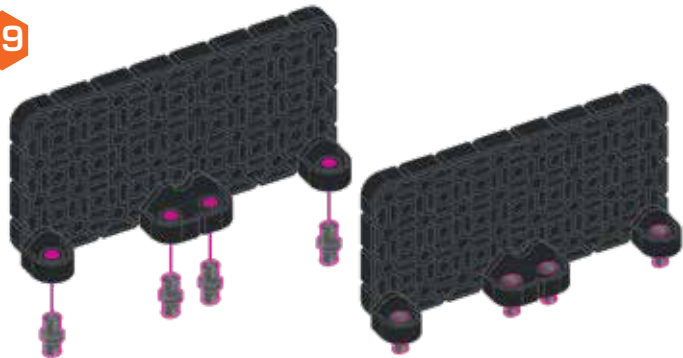

80

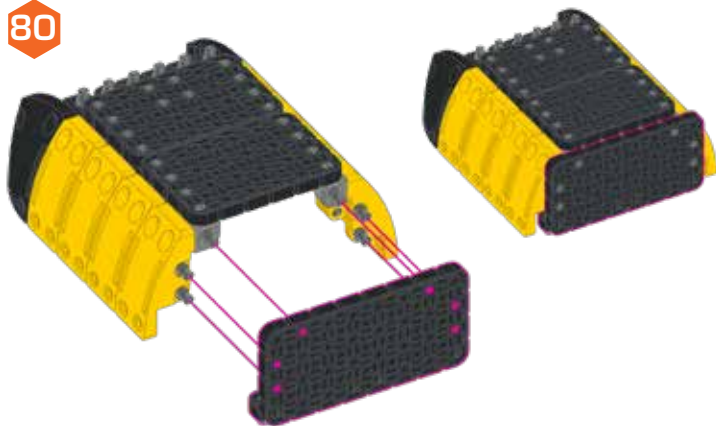

81

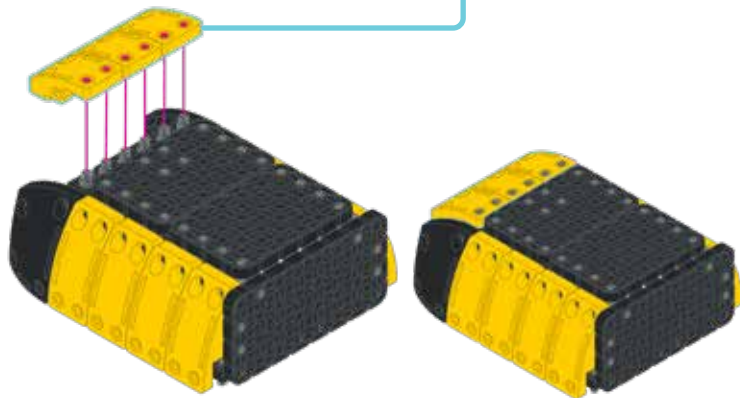
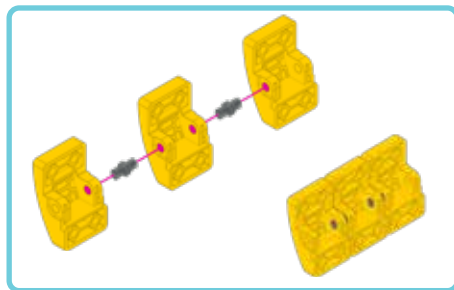

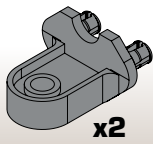

x2

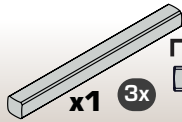

x1 3x

1:1



x2

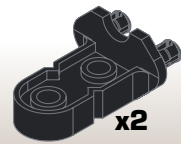

x2

82

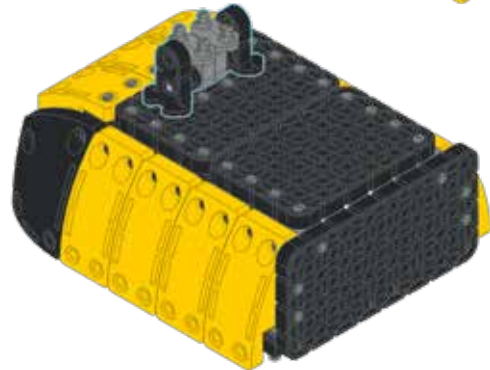
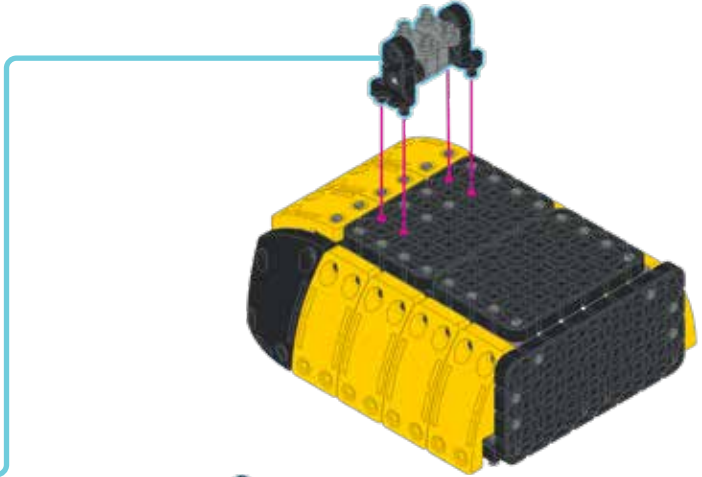
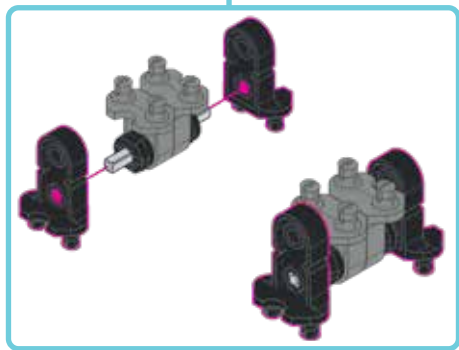
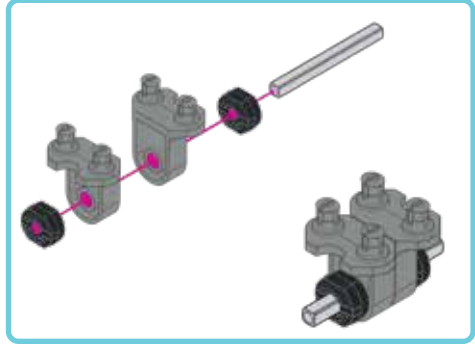

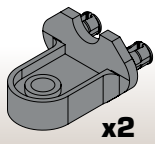

x2

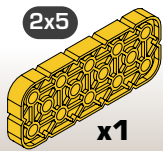

2x5

x1

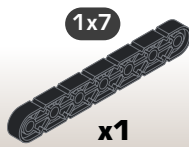

1x7

x1

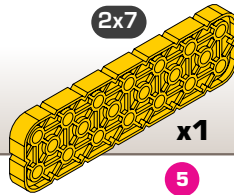

2x7

x1

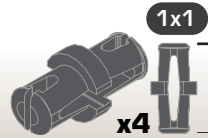

x4

1x1

1:1

83

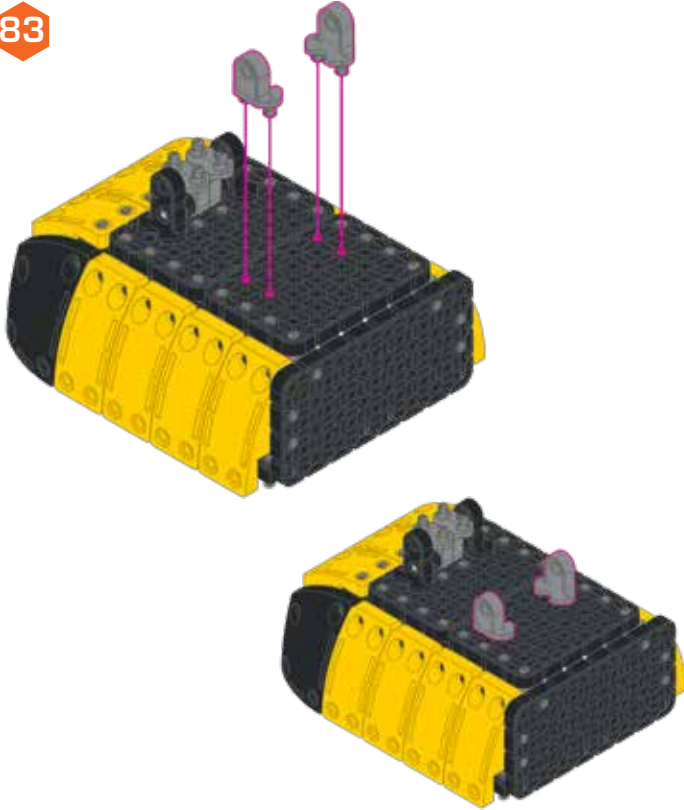

84

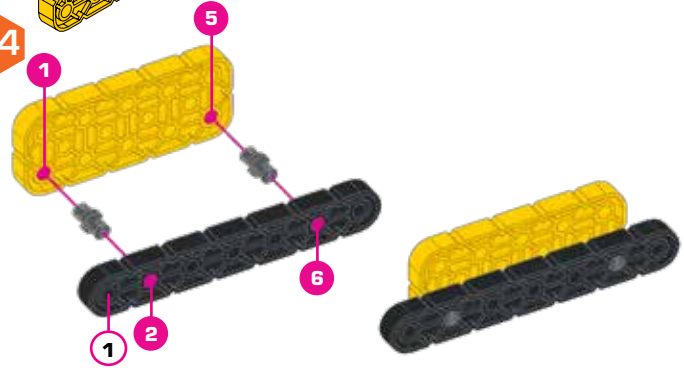

85

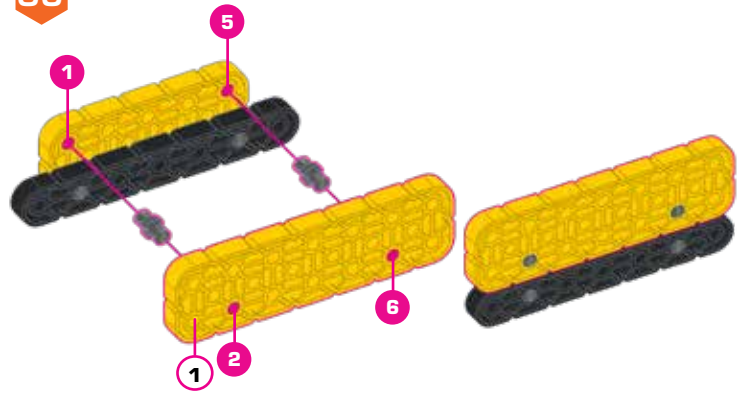

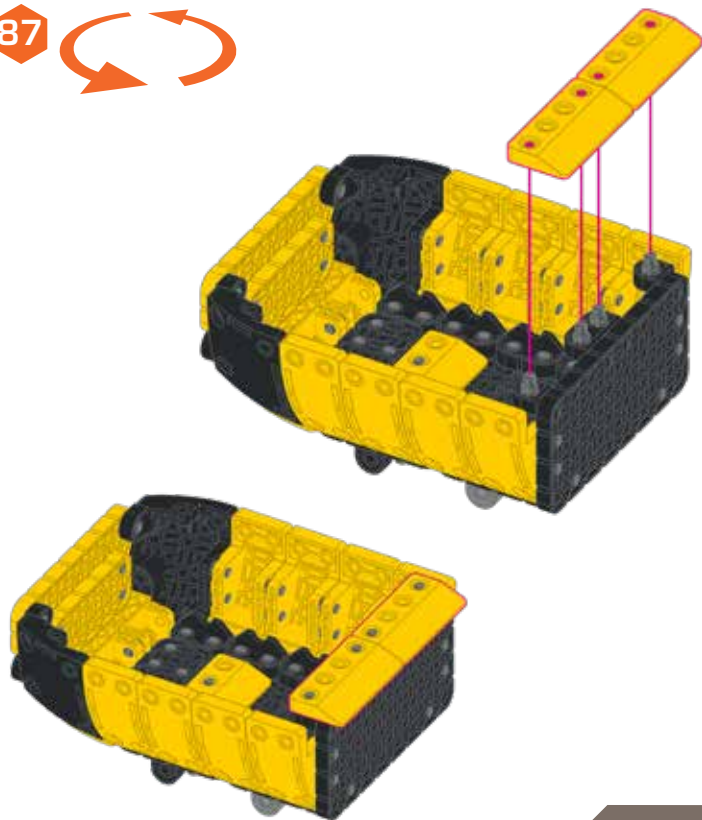
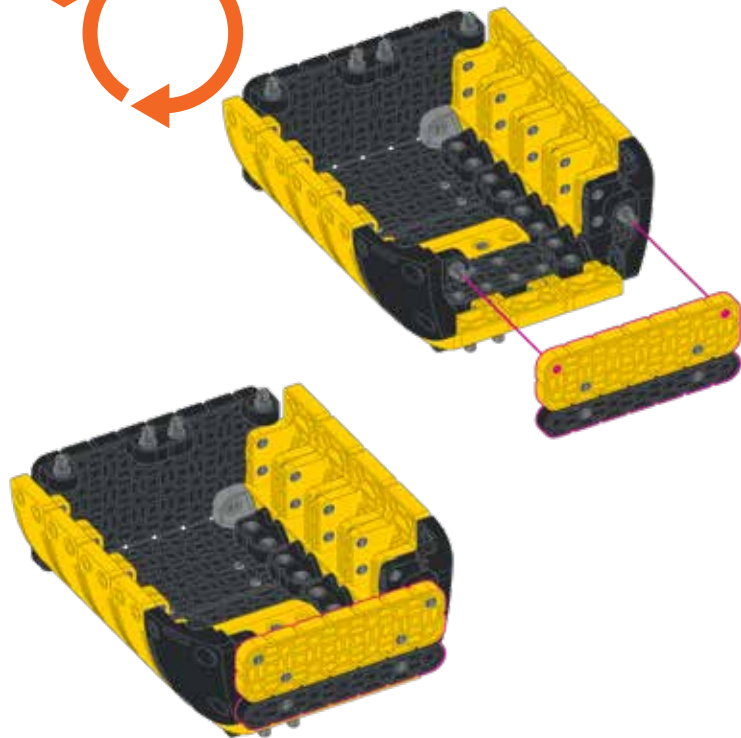
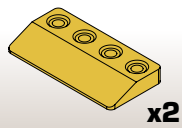



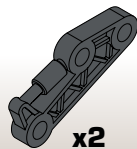

x2

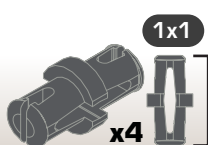

x4

1x1

1:1

89



90



91

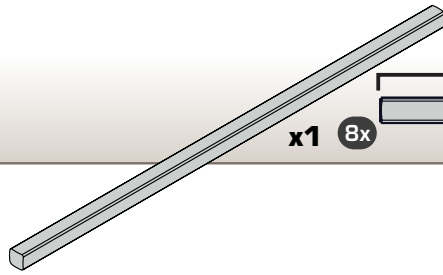

x1 8x

1:1

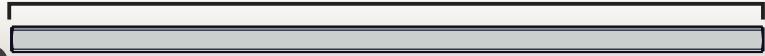



x4

92

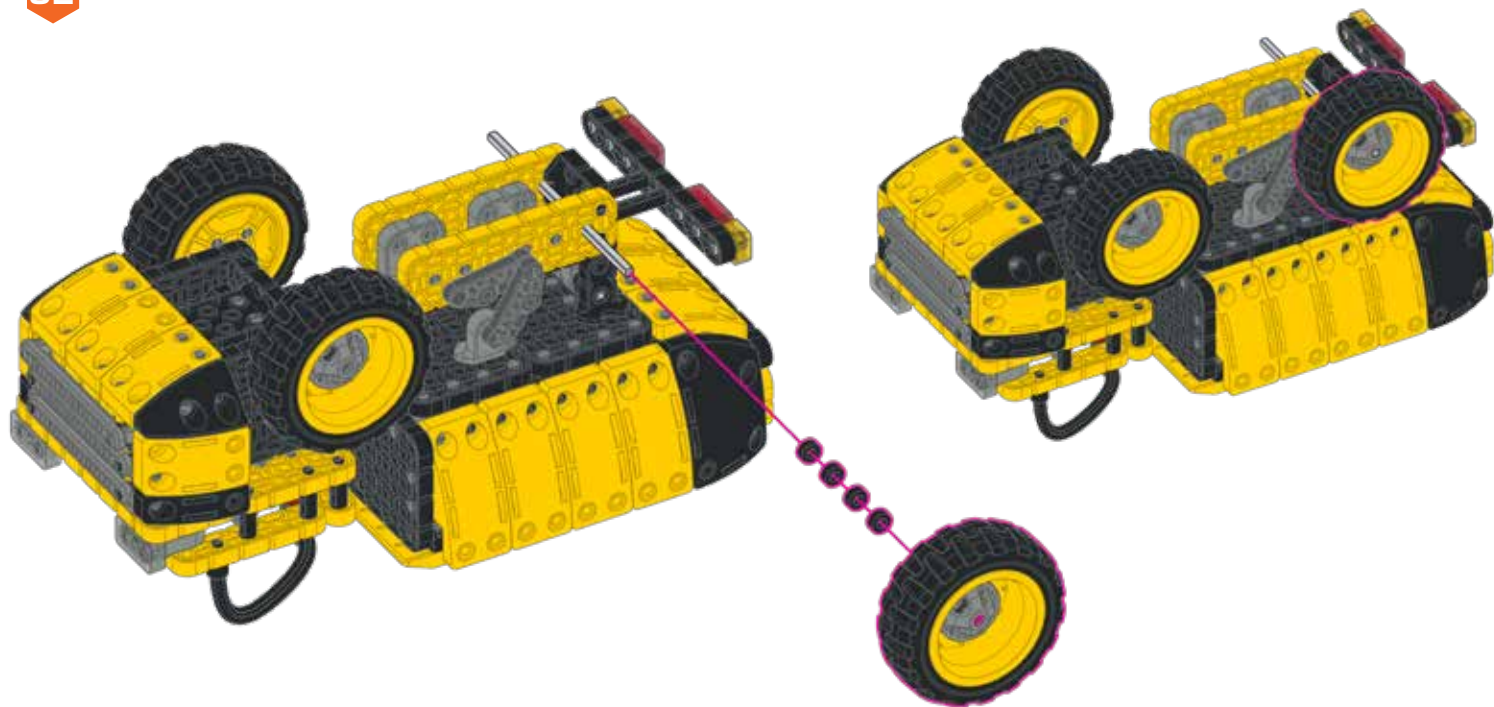



x4

93

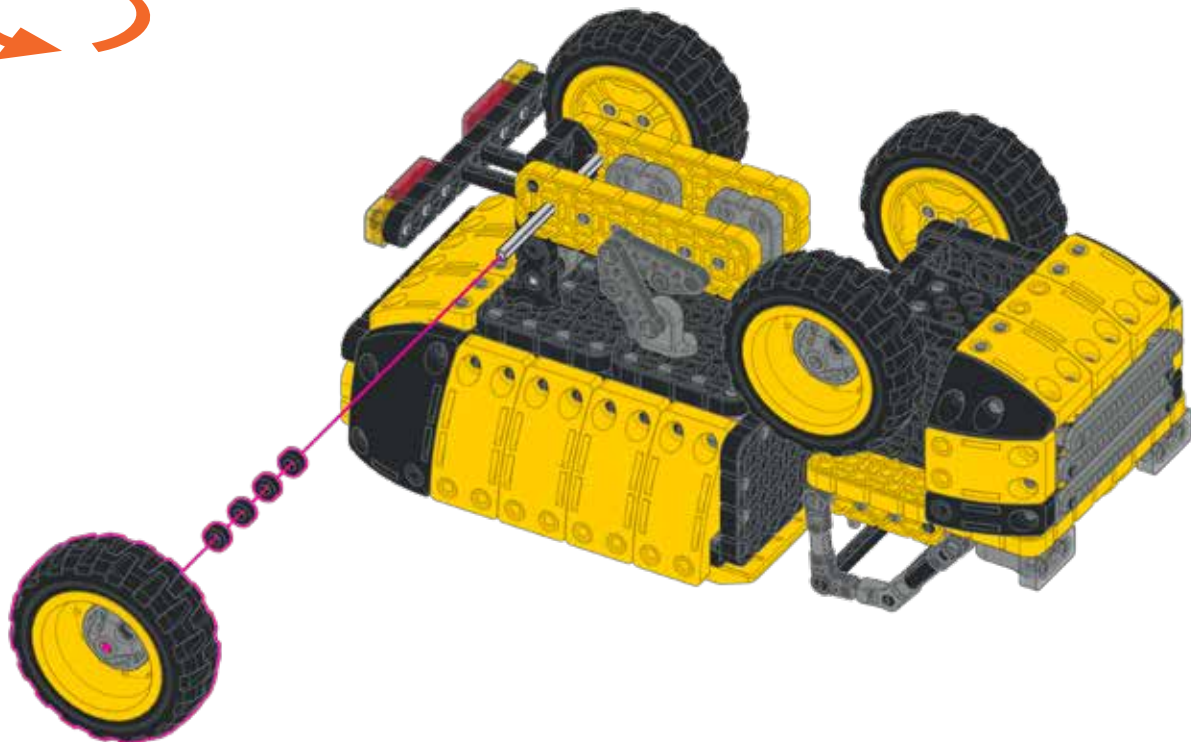
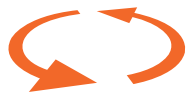

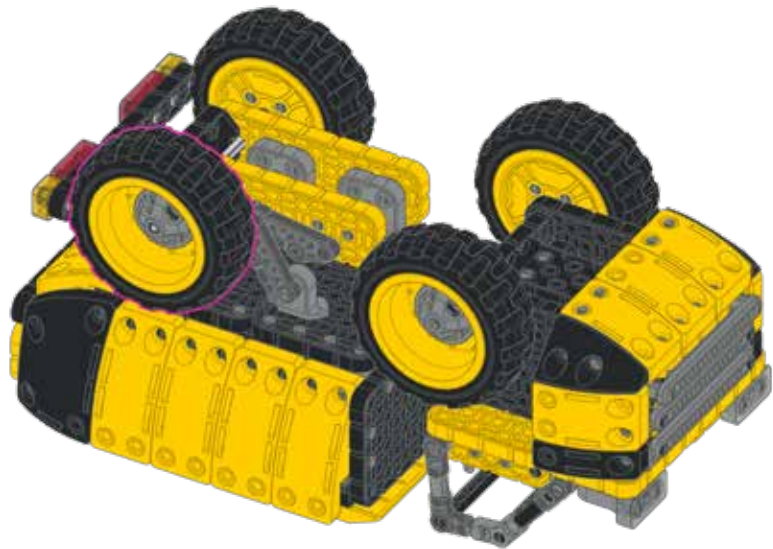
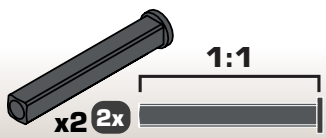

94 2X

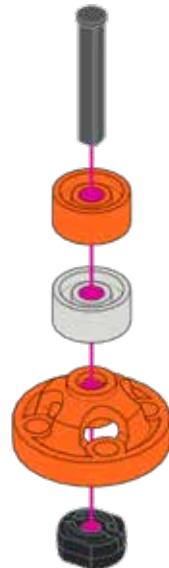

HOW TO/ COMMENT/ CÓMO/ KURZANLEITUNG/ COME FARE/
INSTRUKTAZ/ NÄIN LEIKIT/ GÖR SÅ HÄR/ HVORDAN/ VEJLEDNING/ 使用説明

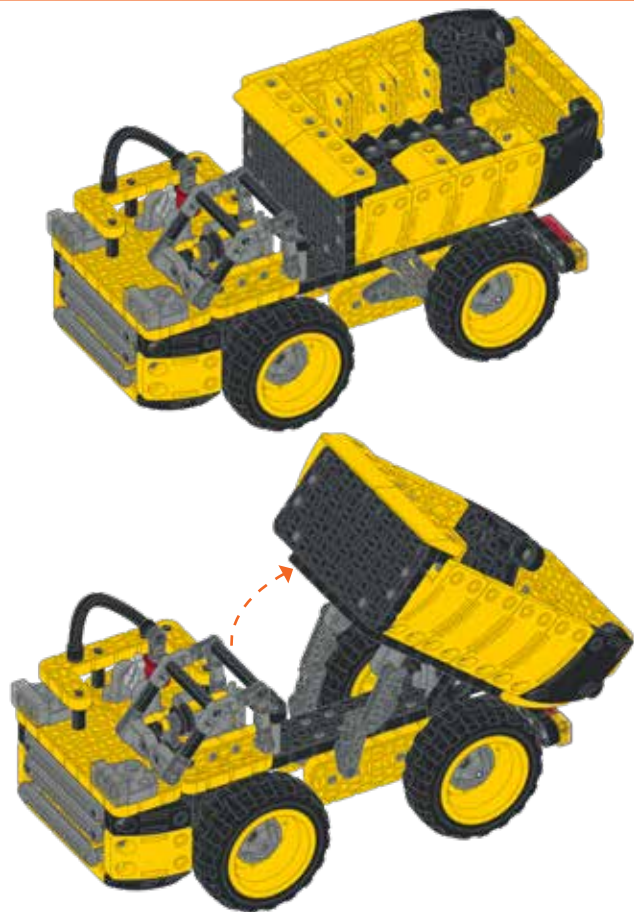



HEXBUG® and VEX® are registered trademarks of/ sont des marques de commerce de/son marcas comerciales de/ ist ein eingetragenes Warenzeichen von/ è un marchio registrato di/jest zastrzeżonym znakiem towarowym firmy/ on rekisteröity tuotemerkki/är ett registrerat varumärke för/er et registreret varemærke tilhørende/ er et registreret varemærke tilhørende/ 赫寶®和VEX®是創首國際的註冊商標 Innovation First, Inc./ The item inside this package may vary from the photographs and/or illustrations. Please retain package for future reference. Please remove all packaging material before giving to children. This product conforms to the safety regulations. Made and assembled in China. Do not put toy in mouth./ L'objet dans cet emballage peut différer des photographies et/ou des illustrations. Veuillez conserver cet emballage pour consultation ultérieure. Enlevez tout l'emballage avant de donner le jouet à des enfants. Ce produit est conforme aux normes de sécurité. Fabriqué et assemblé en Chine. Ne pas mettre le jouet dans la bouche./ El artículo dentro de este empaque puede variar de las fotografías y/o ilustraciones. Conserve este empaque para futuras referencias. Retire todo el material de empaque antes de dar el juguete a los niños. Este producto cumple con las normas de seguridad. Fabricado y ensamblado en China. No se ponga el juguete en la boca. / Der in dieser packung enthaltene artikel kann von den fotos und/oder abbildungen abweichen. Bitte bewahren sie die verpackung auf, damit sie später ggf. auf diese information zurückgreifen können. Entfernen sie sämtliche verpackungsmaterialien, ehe sie das spielzeug einem kind aushändigen. Dieses produkt entspricht den sicherheitsbestimmungen. Hergestellt und zusammengebaut in china. Das spielzeug nicht in den mund stecken./ L'articolo all'interno della confezione può non essere identico alle fotografie e/o illustrazioni. Conservare la confezione per riferimento futuro. Rimuovere tutti i materiali da imballaggio prima di consegnare a bambini. Questo prodotto è conforme alle norme di sicurezza./ Non mettere il giocattolo in bocca / przedmiot wewnątrz opakowania może różnić się wyglądem od zdjęć i/lub ilustracji. Proszę zachować opakowanie jako źródło informacji na przyszłość. Proszę wyjąć produkt z opakowania przed oddaniem go dziecku. Produkt spełnia normy bezpieczeństwa. Valmistettu ja koottu kiinassa / tämän pakkauskesän sisällä oleva tuote voi poiketa valokuvista ja/tai kuvista. Säilytä pakkaus tervalea tarvetta varten. Poista pakkausmateriaalit ennen tuotteen antamista lasten käsiin. Tämä tuote noudattaa turvallisuusmääräyksiä. Tilverkad / Tilverkad / produkten i denna förpackning kan skilja sig från fotografier och/eller illustrationer. Spara förpackningen för framtida referens. Avlägsna allt förpackningsmaterial innan produkten ges till barn. Produkten följer säkerhetsbestämmelserna. Laget og monteret i Kina./ elementet i denne pakke kan variere fra fotografier og/eller tegninger. Gem venligst pakken til fremtidig referens. Fjern al emballage før enheden gives til barn. Dette produkt opfylder sikkerhedsforskrifterne.Fabricado e montado na china./圖片僅供參考。請保留包裝備用。請拆除所有包裝再給小朋友。本產品符合安全要求。中國製造與原裝。不可將玩具放入嘴中。/ Copyright © 2020 Innovation First, Inc. All Rights Reserved/ Tous droits réservés/ Todos los derechos reservados/ Alle Rechte vorbehalten/ Tutti i diritti riservati/ Wszystkie prawa zastrzeżone./ Kaikki oikeudet pidätetään./ Alla rättigheter förbehålles./ Alle Rettigheter Reservert./ Alle rettigheder forbeholdes./版權所有。For information concerning Hexbug's Limited Warranty-- www.hexbug.com/policies; For customer service in your region go to: www.hexbug.com/contact / Pour plus d'informations sur la garantie limitée de Hexbug -- www.hexbug.com/policies; Pour le service client de votre région, rendez-vous sur : www.hexbug.com/contact / Pour plus d'informations sur la garantie limitée de Hexbug -- www.hexbug.com/policies; Pour le service client de votre région, rendez-vous sur : www.hexbug.com/contact / Para obtener información sobre la garantía limitada de Hexbug visite: www.hexbug.com/policies; Para comunicarse con el servicio al cliente de su región visite: www.hexbug.com/contact / Informationen zur eingeschränkten Garantie von Hexbug finden Sie unter: www.hexbug.com/policies; Den Kundendienst in Ihrer Region finden Sie unter: www.hexbug.com/contact / Per informazioni sulla garanzia limitata offerta da Hexbug-- www.hexbug.com/policies; Per il servizio clienti nella propria regione visitare: www.hexbug.com/contact / Per informazioni sulla garanzia limitata offerta da Hexbug-- www.hexbug.com/policies; Per il servizio clienti nella propria regione visitare: www.hexbug.com/contact / Informacje na temat ograniczonej gwarancji Hexbug znajdziesz na stronie www.hexbug.com/policies; Informacje na temat obsługi klienta w Twoim regionie znajdziesz na stronie: www.hexbug.com/contact / Lisätietoja Hexbugin rajoitetusta takuusta: www.amo.fi; Jos haluat asiakaspalvelua alueellasi, siirry osoitteeseen: www.amo-toys.com / För information om Hexbug's Begränsad garanti-- www.hexbug.com/policies; För kundtjänst i din region gå till: www.amo-toys.com / For information om Hexbug's begrænsede garanti-- www.hexbug.com/policies; For kundeservice i din region, gå til: www.amo-toys.com / For information vedgørende Hexbug's Begrænset Garanti-- www.hexbug.com/policies; For kundeservice i dit område gå til: www.amo-toys.com / 關於赫寶質量保證信息--請訪問 www.hexbug.com/policies; 關於售後客服,請訪問: www.hexbug.com/contact Custom manufactured in / Fabriqué sur mesure en / Fabricado a medida en / Hergestellt in / Prodotto in / Op maat gefabriceerd in / Fabricado a medida na / Wykonane na zamówienie w / Mittitilaustyönä valmistettu/ Tilverkad i / Spezialproduzent i / Spezialfremstillet i/ 定制生產於 China For Innovation First Trading SARL. Distributed in the U.S.A. by / Distribué aux états-unis par / Distribuido en los EE. UU. por / Vertrieben in den USA durch / Distribuito negli U.S.A. da / Gedistribueerd in de VS door / Distribuido nos EUA pela / Dystrybuowane w USA przez/ Jaettu USA: ssa/ Distribueras i USA av/ Distribuitur i USA av/Distribueret i USA av/ 美國地區經銷商 Innovation First Labs, Inc., 6725 W. Fm 1570, Greenville, Texas 75402, U.S.A. Distributed in Europe by / Distribuado en Europee par / Distribuido en Europa por / Vertrieben in Europee durch / Distribuito in Europee da / Gedistribueerd in Europee door / Distribuido na Europee pela / Dystrybuowane w Europie przez/ Maahantuja Euroopassa/ Distribueras i Europa av/ Distribuitur i Europa av/ Distribueret i Europa av/ 歐洲地區經銷商 Innovation First Trading SARL, Parc Logistique Eurohug Sud L-3434 Dudelange Luxembourg +352 27 86 04 87. Distributed in Canada by / Distribué au Canada par / Distribuido en Canadá por / Vertrieben in Canada durch / Distribuito in Canada da / Gedistribueerd in Canada door / Distribuido no Canadá pela / Dystrybuowane w Kanadzie przez/Jaettu Kanadassa/ Distribueras i Kanada av/ Distribuitur i Canada av/ Distribueret i Canada av/ 加拿大地區經銷商 Innovation First Trading, Inc., 6725 W. Fm 1570, Greenville, Texas 75402, U.S.A. www.hexbug.com/contact Maahantuja Suomessa / Importör i Finland/ Ansatie 5, 01740 Vantaa/Vanda, www.amo.fi, Kuluttajapalvelu/ Konsumentenservice Suomi +358 20163 0530/ Importör i Sverige, Norge, Danmark: AMO Toys AB, Garnisonsgatan 10, 25466 Helsingborg, www.amo-toys.com. Konsumentenservice Sverige +46 722026142 / Kundeservice Norge +47 46520501 / Kundeservice Danmark +45 72170187 PLEASE KEEP THESE INSTRUCTIONS. Please keep these instructions./Veuillez conserver le mode d'emploi./Por favor conserve la guía de instrucciones./Diese Anleitung bitte aufbewahren./Conserve ueste istruzioni./ Proszę zachować niniejszą instrukcję./ Säilytä nämä ohjeet. / Spara instruktionerna./ Vennligst ta vare på disse instruksjonene. / Gem brugsanvisningen. 請妥善保管說明書



Warning: CHOKING HAZARD – Small parts. DO NOT put in nose or mouth.
Avvertimento: RISQUE D'ASPHYRIE – Ce produit contient de petits éléments. NE PAS mettre dans la nez ou la bouche.
Advertencia: RIESGO DE ASFIMIA – Contiene piezas pequeñas. No lo meta en la nariz o la boca.
Achtung: ERSTICKUNGSGEFAHR – Kleinteile. NICHT in die Nase oder den Mund geben.
Attenzione: RISCHIO DI SOFFOCAMENTO – Pezzi piccoli. NON mettere nel naso o nella bocca.
Ostrzeżenie: NIEBIEZPIECZNIWO ZADRWAENIA – małe części. NIE WOLNO wkładać do nosa ani do ust.
Varoitus: TUKEHTUMISVAARA – Pieniä osia. ÄLÄ laita nenään tai suuhun.
Varoitus: KÄVÄLINGSSIKK – små delar. LÄGG INTE i näsa eller mun.
Advarsel: KVELNINGSSFARE – Små deler. MÅ IKKE puttes i nese eller mund.
Advarsel: KVELNINGSSFARE – Små deler. MÅ IKKE puttes i nase eller mund.
警告: 誤食哽噎的危險-小零件。請勿放入鼻子或嘴中。



<p>WARNING: CHOKING HAZARD-Small parts. Not for children under 3 years.</p>	<p>AVERTISSEMENT: RISQUE D'ÉTOUFFEMENT- Comporté de petites pièces. Ne convient pas aux enfants de moins de 3 ans.</p>	<p>ADVERTENCIA: RISGO DE ASFIMIA- Pequeñas partes. No para niños menores de 3 años.</p>
<p>ACHTUNG: ERSTICKUNGSGEFAHR- Kleinteile. nicht für Kinder unter 3 Jahren</p>	<p>ATTENZIONE: RISCHIO DI SOFFOCAMENTO- Piccole parti. Non adatto a bambini sotto i 3 anni</p>	<p>OSTRZEŻENIE! NIEKOPYDZIAŁAWIENIA- Małe części. Niedopuszczalne dla dzieci poniżej 3 roku życia.</p>
<p>VAROITUS: TUKEHTUMISVAARA- Pieniä osia. Et alle 3-vuotiaalle lapsille.</p>	<p>VARNING: KÄVÄLINGSSIKK- Små delar. Inte avsett för barn under 3 år.</p>	<p>ADVARSEL: KVELNINGSSFARE- Små deler. Ikke for barn under 3 år.</p>
<p>FORSIGTIG: RISIKO FOR KVELNING- Små dele. Ikke egnet til børn under 3 år.</p>	<p>警告: 誤食哽噎的危險-小零件。不適用於三歲以下兒童。</p>	

HEXBUG®

VEX®
ROBOTICS



HEXBUG.COM/VEX

i

Dump Truck
406-7093

LOT #

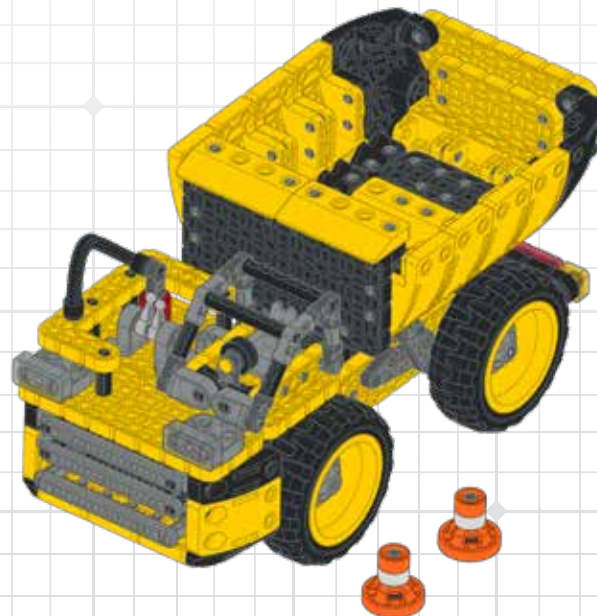

VEX[®]

ROBOTICS

NEED HELP? / NECESITAS AYUDA? / BESOIN D'AIDE? / SERVE AIUTO?? /
HILFE? / POTRZEBUJESZ POMOCY? / TARVITSETKO APUA? / BEHÖVER DU HJÄLP? / TRENGER
DU HJELP? / BRUG FOR HJÆLP? / 需要幫助?

WWW.VEX.COM/HELP