

BLADE

Fusion™ **360**

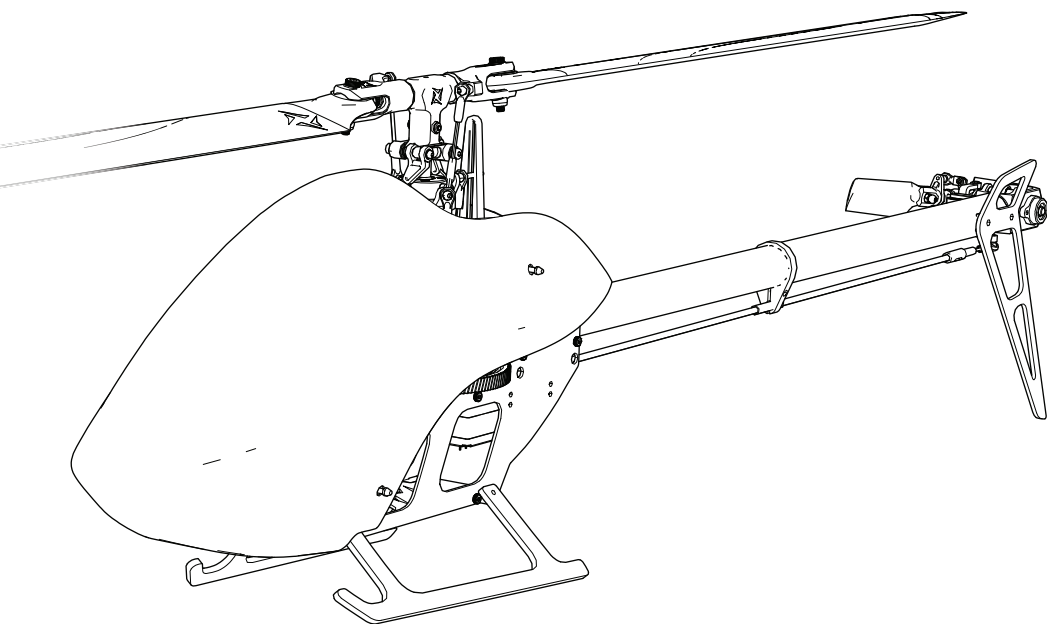

**Instruction Manual
Bedienungsanleitung
Manuel d'utilisation
Manuale di Istruzioni**

BNF
BASIC

HORIZON
H O B B Y

NOTICE

All instructions, warranties and other collateral documents are subject to change at the sole discretion of Horizon Hobby, LLC. For up-to-date product literature, visit horizonhobby.com or www.towerhobbies.com and click on the support or resources tab for this product.

Meaning of Special Language

The following terms are used throughout the product literature to indicate various levels of potential harm when operating this product:

WARNING: Procedures, which if not properly followed, create the probability of property damage, collateral damage, and serious injury OR create a high probability of superficial injury.

CAUTION: Procedures, which if not properly followed, create the probability of physical property damage AND a possibility of serious injury.

NOTICE: Procedures, which if not properly followed, create a possibility of physical property damage AND a little or no possibility of injury.



WARNING: Read the ENTIRE instruction manual to become familiar with the features of the product before operating. Failure to operate the product correctly can result in damage to the product, personal property and cause serious injury.

This is a sophisticated hobby product. It must be operated with caution and common sense and requires some basic mechanical ability. Failure to operate this Product in a safe and responsible manner could result in injury or damage to the product or other property. This product is not intended for use by children without direct adult supervision. Do not use with incompatible components or alter this product in any way outside of the instructions provided by Horizon Hobby, LLC. This manual contains instructions for safety, operation and maintenance. It is essential to read and follow all the instructions and warnings in the manual, prior to assembly, setup or use, in order to operate correctly and avoid damage or serious injury.

Age Recommendation: Not for children under 14 years. This is not a toy.

Safety Precautions and Warnings

As the user of this product, you are solely responsible for operating in a manner that does not endanger yourself and others or result in damage to the product or the property of others.

- Always keep a safe distance in all directions around your model to avoid collisions or injury. This model is controlled by a radio signal subject to interference from many sources outside your control. Interference can cause momentary loss of control.
- Always operate your model in open spaces away from full-size vehicles, traffic and people.
- Always carefully follow the directions and warnings for this and any optional support equipment (chargers, rechargeable battery packs, etc.).
- Always keep all chemicals, small parts and anything electrical out of the reach of children.
- Always avoid water exposure to all equipment not specifically designed and protected for this purpose. Moisture causes damage to electronics.
- Never place any portion of the model in your mouth as it could cause serious injury or even death.
- Never operate your model with low transmitter batteries.
- Always keep aircraft in sight and under control.
- Always move the throttle fully down at rotor strike.
- Always use fully charged batteries.
- Always keep transmitter powered on while aircraft is powered.
- Always remove batteries before disassembly.
- Always keep moving parts clean.
- Always keep parts dry.
- Always let parts cool after use before touching.
- Always remove batteries after use.
- Never operate aircraft with damaged wiring.
- Never touch moving parts.



WARNING AGAINST COUNTERFEIT PRODUCTS: If you ever need to replace a Spektrum™ component found in a Horizon Hobby product, always purchase from Horizon Hobby, LLC or a Horizon Hobby authorized dealer to ensure authentic high-quality Spektrum™ product. Horizon Hobby, LLC disclaims all support and warranty with regards, but not limited to, compatibility and performance of counterfeit products or products claiming compatibility with DSM® or Spektrum™ technology.

Table of Contents

First Flight Preparation.....	4	Post-Flight Inspections and Maintenance	10
Flying Checklist.....	4	Advanced Tuning (Forward Programming)	11
LED Indicator on Flight Controller	4	Advanced Tuning (Non-Forward Programming).....	12
Low Voltage Cutoff (LVC)	4	Troubleshooting Guide.....	14
Electronic Speed Controller Governor Operation	4	Exploded View.....	15
Transmitter Setup	5	Parts List.....	17
Transmitter Setup	6	Recommended Parts List	17
Installing the Flight Battery.....	7	Optional Parts List.....	17
Transmitter and Receiver Binding.....	7	Ball Bearing Sizes	17
Throttle Hold	8	Limited Warranty.....	18
Control Tests	8	Warranty and Service Contact Information.....	19
Pre-Flight Checklist.....	9	FCC Information	19
Flying the Blade Fusion 360	9	IC Information	20
Gyro Gain Adjustment.....	10	Compliance Information for the European Union	20
Tail Belt Tension	10		

Specifications

Length	26.9 in (685mm)	Main Rotor Diameter	31.3 in (796mm)
Height	26.9 in (190mm)	Tail Rotor Diameter	6.9 in (175mm)
Flying Weight	32.2 oz (915 g)		

Components

		BNF Basic
Airframe	Blade® Fusion 360	Included
Motors	Brushless Out-Runner Motor, 1800Kv (BLH4731)	Installed
Receiver	Flight Controller/Receiver (SPMFC6250HX, SPM4649T)	Installed
ESC	Brushless 60A ESC (BLHHW60A)	Installed
Swash Servos	Sub-Micro Digital Heli Cyclic MG Servo (SPMSH3055)	Installed
Tail Servo	Sub-Micro Digital Heli Tail MG Servo (SPMSH3065)	Installed
Battery	Spektrum™ 6S, 22.2 V LiPo Battery, 1800mAh, 50C, IC3™ (SPMX18006S50)	Required
Charger	Li-Po Balancing Charger	Required
Transmitter	Full Range DSM2®/DSMX® technology transmitter	Required

Box Contents

- Blade® Fusion™ 360 helicopter

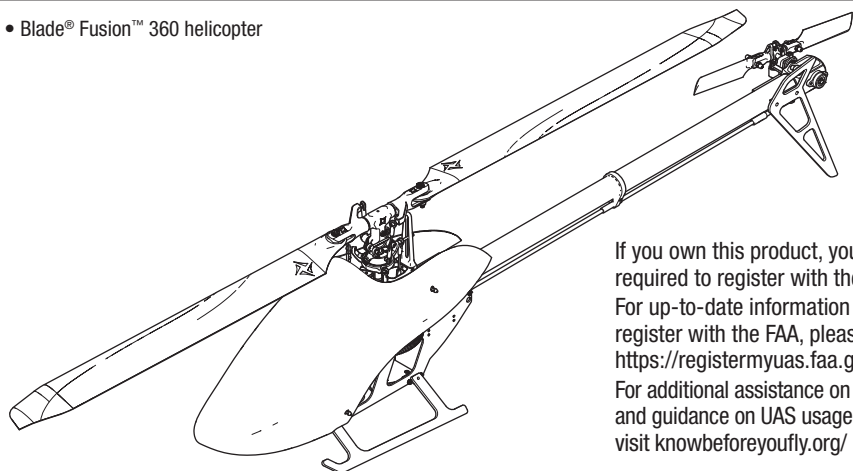

If you own this product, you may be required to register with the FAA. For up-to-date information on how to register with the FAA, please visit <https://registermyuas.faa.gov/>. For additional assistance on regulations and guidance on UAS usage, visit knowbeforeyoufly.org/

To receive product updates, special offers and more, register your product at www.horizonhobby.com

First Flight Preparation

- Remove and inspect contents
- Begin charging the flight battery (not included)
- Install the flight battery in the helicopter (once it has been fully charged)
- Program your computer transmitter
- Bind your transmitter
- Familiarize yourself with the controls
- Find a suitable area for flying

Flying Checklist

- Always turn the transmitter on first
- Plug the flight battery into the lead from the ESC
- Allow the ESC to initialize and arm properly
- Verify control directions and gyro compensations are correct
- Fly the model
- Land the model
- Unplug the flight battery from the ESC
- Always turn the transmitter off last

LED Indicator on Flight Controller

LED Indicator on FC	Indicator Description
Red Solid	FC6250HX waiting for receiver connection, system will not initialize until connected
Yellow Flash	Calibrating
Slow Green Flash	Ready to Fly
Slow Red Flash	Failsafe Active
Red Solid and Yellow Flash	Calibration Error, FC not level or is being moved during calibration

Low Voltage Cutoff (LVC)

The ESC will continuously lower power to the motor until complete shutdown when the battery reaches 12V under load. This helps prevent over-discharge of the Li-Po battery. Land immediately when the ESC activates LVC. Continuing to fly after LVC can damage the battery, cause a crash or both. Crash damage and battery damaged due to over-discharge are not covered under warranty.

Repeatedly flying the helicopter until LVC activates will damage the helicopter battery.

Disconnect and remove the Li-Po battery from the aircraft after use to prevent trickle discharge. During storage, make sure the battery charge does not fall below 3V per cell.

Electronic Speed Controller Governor Operation

The included electronic speed controller (ESC) utilizes a head speed governor to maintain a constant head speed during flight. The governor will work to maintain a constant head speed throughout maneuvers and the discharge cycle of the flight battery.

The throttle position determines the requested head speed, and although throttle curves are still used, they will be a constant value; all positions of the curve are set to the same value. The lowest position of the normal flight mode throttle curve must be set to 0 to ensure the motor can be disabled.

The default throttle curve settings listed in the transmitter setup tables should be acceptable to most pilots and we recommend starting with these values. If you feel an adjustment is necessary after a few flights, adjust the throttle percentage for the desired flight mode. We recommend making small changes of 5% to find your preferred head speed.

Remember the throttle position on the transmitter is simply requesting a specific head speed and this is not related to the actual motor power percentage.

Transmitter Setup

Program your transmitter before attempting to bind or fly the helicopter. Always start by creating a new model in the transmitter to ensure no existing settings are inadvertently used. Transmitter programming values are shown below for the

Spektrum™ transmitters. The files for models using Spektrum™ transmitters with Spektrum AirWare™ software are also available for download online at www.spektrumrc.com.

DX6i

SETUP LIST

Model Type	HELI
Swash Type	1 servo 90

Reverse

Channel	Direction
All Channels	N

Modulation Type

AUTO DSMX-ENABLE

D/R COMBI

D/R SW	AILE
--------	------

Timer

Down Timer	4:00
Switch	THR CUT

ADJUST LIST

TRAVEL ADJ		D/R & Expo			
Channel	Travel	Channel	Sw Pos	D/R	Expo
All Channels	100/100	AILE/ELEV/ RUDD	0	100	0
			1	85	0

Throttle Curve

Switch Pos (F Mode)	Pos 1	Pos 2	Pos 3	Pos 4	Pos 5
NORM	0	60	60	60	60
STUNT*	80	80	80	80	80

Pitch Curve

Switch Pos (F Mode)	Pos 1	Pos 2	Pos 3	Pos 4	Pos 5
NORM	25	37	50	75	100
STUNT	0	25	50	75	100
HOLD	25	37	50	75	100

GYRO

RATE		SW-F.MODE	
Switch Pos (F Mode)			
0	82%	NORM	0
1	75%	STUNT	1

Mix 1

GYRO > GYRO		ACT	
RATE		D+125%	U+125%
SW		ELE D/R	TRIM-INH

DX7s, DX8

SYSTEM SETUP

Model Type	
HELI	
Swash Type	
1 servo Normal	
F-Mode Setup	
Flight Mode	F Mode
Hold	Hold
SW Select	
Trainer	AUX 2
F Mode	Gear
Gyro	INH
Mix	INH
Hold	INH
Knob	INH
Frame Rate	
11ms	
DSMX	

FUNCTION LIST

Servo Setup						
Channel	Travel	Reverse				
All Channels	100/100	Normal				
D/R & Expo						
Chan	Switch Pos (Ail D/R)		D/R	Expo		
	DX7s	DX8				
AILE/ ELEV/ RUDD	0	0	100/100	0		
	1	1	85/85	0		
	1	2	85/85	0		
Gyro						
Normal		75%				
Stunt 1		75%				
Hold		75%				
Channel		Gear				
SW		F Mode				
Throttle Curve						
Switch Pos (F Mode)						
DX7s	DX8	Pt 1	Pt 2	Pt 3	Pt 4	Pt 5
N	N	0	45	50	50	50
	1	60	60	60	60	60
1	2	75	75	75	75	75
HOLD	HOLD	0	0	0	0	0
Pitch Curve						
Switch Pos (F Mode)						
DX7s	DX8	Pt 1	Pt 2	Pt 3	Pt 4	Pt 5
N	N	30	40	50	75	100
	1	0	25	50	75	100
1	2	0	25	50	75	100
HOLD	HOLD	0	25	50	75	100
Timer						
Mode		Count Down				
Time		3:00 Tone				
Start		Throttle Out				
Over		25%				

Transmitter Setup

DX6G2, DX6e, DX7G2, DX8G2, DX8e, DX9, iX12, DX18, DX20

SYSTEM SETUP

Model Type	HELI
Swash Type	Normal
F-Mode Setup	
Switch 1	Switch B
Switch 2	Inhibit
Hold Switch	Switch H
	0 1

Channel Assign	
Channel Input Config	
1 Throttle	
2 Aileron	
3 Elevator	
4 Rudder	
5 Gear	INH
6 Collective	
7 AUX 2*	

Frame Rate	
11ms*	
DSMX	

* Function is not available on all transmitters

FUNCTION LIST

Servo Setup					
Channel	Travel	Reverse	Channel	Travel	Reverse
THR	100/100	Normal	PIT	100/100	Normal
AIL	100/100	Normal	AX2*	100/100	Normal
ELE	100/100	Normal	AX3*	100/100	Normal
RUD	100/100	Normal	AX4*	100/100	Normal
GER	100/100	Normal			

D/R & Expo			
Chan	Sw (F) Pos	D/R	Expo
AILE	0	100/100	0
	1	85/85	0
	2	85/85	0
ELEV	0	100/100	0
	1	85/85	0
	2	85/85	0
Rudd	0	100/100	0
	1	85/85	0
	2	85/85	0

Gyro	
Normal	85%
Stunt 1	78%
Stunt 2	65%
Hold	85%
Channel	Gear
Switch	Flight Mode

Mixing		
P-Mix 1	Normal	
	Channels	Ger > Gyr
	Rate	125%/0%
	Offset	-100%
	Switch	Switch I
	Position	0 1

Throttle Curve						
Sw Pos (B)	Pt 1	Pt 2	Pt 3	Pt 4	Pt 5	
N	0	60	60	60	60	
1	65	65	65	65	65	
2	80	80	80	80	80	
Hold	0	0	0	0	0	

Pitch Curve						
Sw Pos (B)	Pt 1	Pt 2	Pt 3	Pt 4	Pt 5	
N	25	37	50	75	100	
1	0	25	50	75	100	
2	0	25	50	75	100	
HOLD	25	37	50	75	100	

Timer	
Mode	Count Down
Time	5:00
Start	Throttle Out
Over	5%
One Time	Inhibit

Installing the Flight Battery

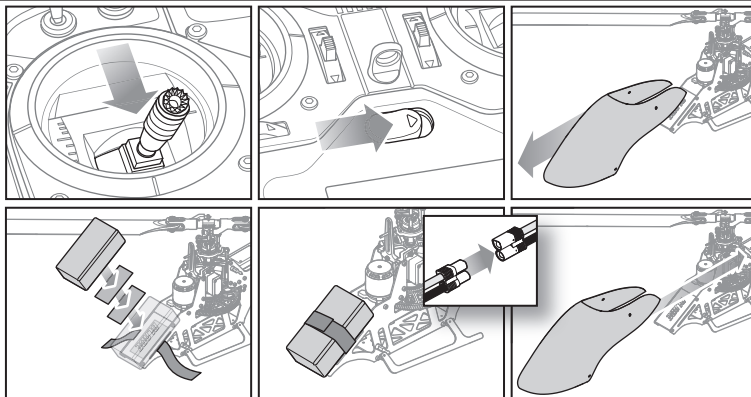

1. Lower the throttle.
2. Power on the transmitter.
3. Center all trims.
4. To allow the ESC to arm and to keep rotors from initiating at startup, turn on throttle hold and normal flight mode before connecting the flight battery.
5. Attach hook material to the helicopter frame and loop material to the battery.
6. Install the flight battery on the helicopter frame. Secure the flight battery with a hook and loop strap. Connect the battery cable to the ESC.
7. Do not move the helicopter until the flight controller initializes. The swashplate will center, indicating that the unit is ready. The flight controller status LED will display a slow green flash once initialization has been completed.
8. The helicopter motor will emit a series of tones, indicating the ESC is armed.



CAUTION: Make sure the flight battery, wire and connector does not come into contact with the motor. Failure to do so will cause the motor, ESC and battery to overheat, resulting in a crash causing property damage and injury.



CAUTION: Always disconnect the Li-Po battery from the ESC power lead when not flying to avoid over-discharging the battery. Batteries discharged below the lowest approved voltage may become damaged, resulting in loss of performance and potential fire when batteries are charged.

Transmitter and Receiver Binding

Binding is the process of programming the receiver to recognize the GUID (Globally Unique Identifier) code of a single specific transmitter. You need to 'bind' your chosen Spektrum™ DSM2®/DSMX® technology equipped aircraft transmitter to the receiver for proper operation.

Binding Procedure

1. Program your transmitter using the Transmitter Setup found in this manual.
2. Insert the bind plug in the BIND port on the wiring harness between the flight controller and the receiver.
3. Connect the flight battery to the ESC. The orange LED on the receiver will begin flashing rapidly to indicate bind mode.
4. Move the throttle stick to the low throttle position in normal mode.
5. Follow the procedures of your specific transmitter to enter bind mode. The system will connect within a few seconds. Once connected, the orange LED on the receiver will come on solid orange.
6. Disconnect the flight battery and remove the bind plug. Store the bind plug in a convenient place.

NOTICE: Remove the bind plug to prevent the system from entering bind mode the next time the power is turned on.



CAUTION: When using a Futaba® transmitter with a Spektrum™ DSM2® module, you must reverse the throttle channel.

If you encounter problems, obey binding instructions and refer to transmitter troubleshooting guide for other instructions. If needed, contact the appropriate Horizon Product Support office.

Throttle Hold

Throttle hold is used to prevent the motor from powering on inadvertently. For safety, turn throttle hold ON any time you need to touch the helicopter or check the direction controls.

Throttle hold is also used to turn off the motor quickly if the helicopter is out of control, in danger of crashing, or both.

The blades will continue to spin briefly when throttle hold is activated. Pitch and direction control is still maintained.

Control Tests



CAUTION: You must complete the Tail Rotor and Cyclic tests prior to every flight. Failure to complete the tests and ensuring the sensor corrects in the proper direction can cause the helicopter to crash, resulting in property damage and injury.

Tail Rotor

1. Power on the transmitter.
2. Turn TH HOLD ON and put transmitter in normal mode.
3. Connect the flight battery to the ESC.
4. Once Initialization is complete the LED on the FC6250HX will begin flashing green.

5. Move the rudder stick to the right. The pitch slider on the tail shaft should move toward the tail case. If the pitch slider moves in the opposite direction, ensure the rudder channel reverse setting within the transmitter is set to normal.

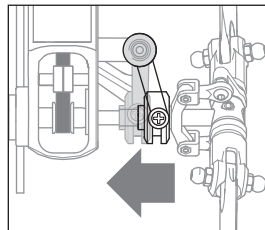

6. Release the rudder control. Manually turn the helicopter nose to the left. The flight controller should compensate by moving the tail slider towards the tail case.

Cyclic

When using a flybarless flight controller, you are controlling rotational rates while the SPMAR6250HX controls the servos. You are not directly controlling the servos with the transmitter.

It is normal for the swashplate to slowly move back to its original position after a stick input and for the servos to not move at the same speed as your control sticks.

1. Tilt the helicopter forward. The swashplate must tilt backward.
2. Roll the helicopter left. The swashplate must roll right.

Cyclic and Collective Control Test

Ensure the throttle hold is ON when performing the direction control tests. Test the controls prior to each flight to ensure the servos, linkages and parts operate correctly. If the controls do not react as shown in the illustrations below, confirm the transmitter is programmed correctly before continuing on to the Motor test.

Elevator

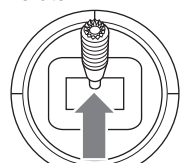

Elevator down

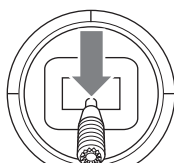
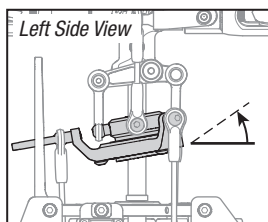

Elevator up

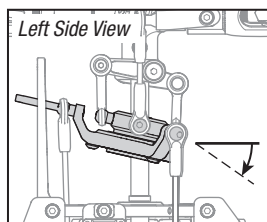

Aileron

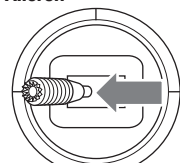

Aileron left

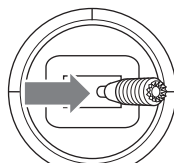
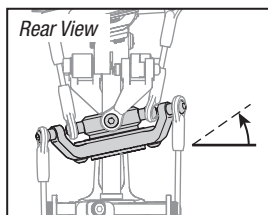

Aileron right

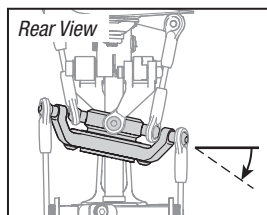

Collective Pitch

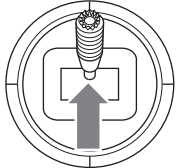

Collective pitch up

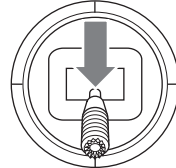
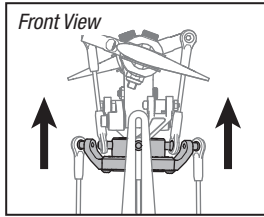

Collective pitch down

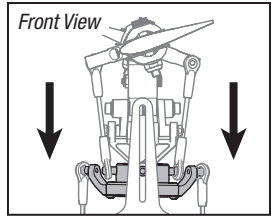

Motor Test

Place the helicopter outdoors on a clean, flat and level surface (concrete or asphalt) free of obstructions. Always stay clear of moving rotor blades.

1. Before you continue, confirm that TH HOLD is ON. The motor will emit a series of tones after the helicopter's ESC has armed properly.

WARNING: The motor will spin when the throttle is increased while TH HOLD is OFF.

WARNING: Stay at least 30 feet (10 meters) away from the helicopter when the motor is running. Do not attempt to fly the helicopter at this time.

2. Ensure the throttle is lowered completely. Confirm the transmitter is still set to normal flight mode. Turn throttle hold OFF to enable throttle control. Slowly increase the throttle until the blades begin to spin. The main blades spin clockwise when viewing the helicopter from the top. The tail rotor blades spin counterclockwise when viewing the helicopter from the right-hand side.

Pre-Flight Checklist

- Check all screws and ensure that they are tight
- Check belt tension and ensure that it is not too tight or too loose
- Check main and tail blades to ensure they are not damaged
- Check all links and make sure they move freely but do not pop off easily
- Check that the transmitter and flight batteries are fully charged
- Check all wires to ensure that they are not cut, pinched, or chaffed and are properly secured
- Check all wire connections
- Check gears and make sure no teeth are missing
- Make sure flight battery is properly secured
- Make sure the receiver is properly secured
- Perform a complete control test
- Verify the flight controller is correcting in the proper directions
- Check that servos are functioning properly

Flying the Blade Fusion 360

Consult local laws and ordinances before choosing a location to fly your aircraft.

Select a large, open area away from people and objects. Your first flights should be outdoors in low-wind conditions. Always stay at least 30 feet (10 meters) away from the helicopter when it is flying.

The Blade Fusion 360 is intended to be flown outdoors by experienced pilots.

Takeoff

Deliberately increase throttle and establish a hover at least 24" (0.6 meter) high, outside of ground effect.

CAUTION: Making large inputs to the roll or pitch controls while the helicopter is on the ground may result in a crash.

Flying

The helicopter lifts off the ground when the rotor head reaches a suitable speed. Establish a low-level hover to verify proper operation of your helicopter.

First flights should be performed in normal mode and low cyclic and rudder dual rates until you are familiar with the flying manner of the Blade Fusion 360.

CAUTION: Always fly the helicopter with your back to the sun and the wind to prevent loss of flight control.

Landing

Establish a low level hover. Deliberately lower the throttle until the helicopter lands.

When the helicopter is in stunt mode:

- The rotor head speed is constant.
- The main rotor will increase negative pitch as the throttle/collective stick is moved from the middle stick position to the low stick position. Negative pitch allows the helicopter to fly upside down and perform aerobatics.

Change between stunt and idle up modes in a hover with the throttle near the hovering stick position.

WARNING: Do not use wooden main blades with the Blade Fusion 360. Injury and/or property damage could occur. Only use Blade Fusion 360 replacement carbon fiber main blades.

Gyro Gain Adjustment

- If the tail wags or oscillates, lower the gain on the gyro.
In the transmitter gyro menu, decrease the gyro gain values a small amount at a time until the helicopter is stable within a particular flight mode.
- If the tail is drifting while hovering, increase the gain on the gyro.
In the transmitter gyro menu, increase the gyro gain values a small amount at a time until the tail starts to wag/oscillate. Afterwards, reduce the gain until the tail stops wagging/oscillating within a particular flight mode.

Tail Belt Tension

Belt tension that is too tight results in loss of power and causes the belt to wear more quickly. Tension that is too loose can cause belt damage and loss of tail rotor control in flight.

To check for proper belt tension:

1. View the tail rotor drive belt through the opening at the back of the main frame.
2. Use a hex wrench or standard screwdriver to compress the belt through the opening.
3. Apply light pressure on the belt, compressing the belt toward the left side of the tail boom.
4. The belt tension is correct if the compressed side of the belt reaches approximately halfway to the opposite side of the belt.
 - a. *If the compressed side of the belt reaches farther than halfway to the other side of the belt, the tension is too loose.*
 - b. *If the compressed side of the belt does not reach halfway to the other side of the belt, the tension is too tight.*

To adjust belt tension:

1. Loosen the two screws at the back of the main frame.

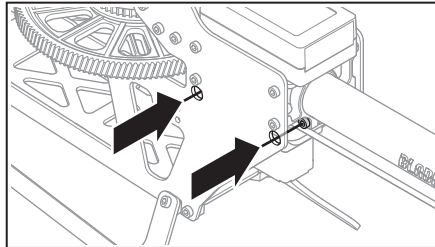

2. Slide the boom forward or aft to adjust the belt tension.
3. When the belt tension is properly adjusted, tighten the two screws at the back of the frame.

Post-Flight Inspections and Maintenance

Ball Links	Make sure the plastic ball link holds the control ball, but is not tight (binding) on the ball. When a link is too loose on the ball, it can separate from the ball during flight and cause a crash. Replace worn ball links before they fail.
Cleaning	Make sure the battery is not connected before cleaning. Remove dust and debris with a soft brush or a dry lint free cloth.
Bearings	Replace bearings when they become damaged.
Wiring	Make sure wiring does not block moving parts. Replace damaged wiring and loose connectors.
Fasteners	Make sure there are no loose screws, other fasteners or connectors. Do not over tighten metal screws in plastic parts. Tighten screw so parts are mated together, then turn screw only 1/8th of a turn more.
Rotors	Make sure there is no damage to rotor blades and other parts which move at high speed. Damage to these parts includes cracks, burrs, chips or scratches. Replace damaged parts before flying.
Flight Controller	Make sure the flight controller is securely attached to the frame. Replace the double-sided tape when necessary. The helicopter will crash if the flight controller separates from the helicopter frame.

Advanced Tuning (Forward Programming)

Applies to forward programming capable Spektrum Transmitters including DX6G2, DX7G2, DX8G2, DX9, iX12, DX18, DX20

The Fusion 360 default settings are appropriate for most users. We recommend flying with the default parameters before making any adjustments.

The Fusion 360 BNF flight controller may be programmed from any compatible Spektrum transmitter (visit SpektrumRC.com for more information).

The flight controller shipped with BNF models has a range of adjustable parameters suitable for the Fusion 360 Helicopter and is not intended for use in other aircraft.

It is important to use the included servos with the BNF flight controller because the adjustable parameters available for the SPMAR6250HX are designed around the recommended servos. It is possible there may not be enough range for the helicopter to be tuned when using alternative servos.

Entering the Advanced Parameters Menu

With the helicopter bound to the transmitter and powered on, enter the Function List and select Forward Programming. The list of adjustable parameters and the range of values available for tuning have been tailored for this helicopter. Make small changes to one parameter at a time and test fly the changes before changing the parameter further or changing a different parameter.

Calibration Procedure:

If the helicopter is experiencing drift issues, perform the following calibration. The calibration procedure may also be needed following crash repairs.

1. Ensure the surface used for calibration is level.
2. Power on the transmitter and activate throttle hold.
3. Connect the flight batter to the ESC and allowing the model to initialize.
4. Turn Throttle Hold ON.
5. Using a bubble level as shown below, level the helicopter by placing a shim under the landing skid.
6. Enter the Function List on your transmitter.
7. Select Forward Programming.
8. Select System Setup.
9. Select Calibration.
10. Select Apply and the calibration will begin. The LED will flash yellow indicating the calibration is proceeding normally. If the LED changes to red this indicates the model is not near level or the model was moved, in this case the calibration starts over.
11. After the calibration is successfully completed, the receiver LED will change to a slow green flash which indicates the calibration has completed.
12. Proceed to the pre-flight check list procedure before flying your model.

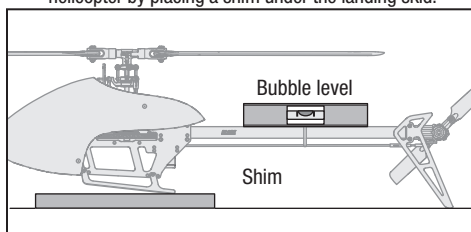

Factory Reset

If the process of tuning the Fusion 360 helicopter results in undesirable flight performance, you can reset the settings back to factory defaults by selecting the Factory Reset option in Forward Programming.

1. Enter the Function List
2. Select Forward Programming
3. Select System Setup
4. Select Factory Reset
5. Select Apply
6. Perform the Setup->Swashplate->Sub Trim function and ensure the servos are properly trimmed.
7. Proceed with the pre-flight check list procedure before flying the model.

Advanced Tuning (Non-Forward Programming)

Applies to Spektrum transmitters not capable of forward programming including DX6i, DX6e, DX7s DX8, and DX8e

Your Blade Fusion 360 was setup at the factory and test flown. The servo adjustment steps are usually only necessary in special circumstances, such as after a crash or if a servo or linkage is replaced.

For pilots flying with a transmitter not capable of forward programming use the following procedures to make servo adjustments and perform the calibration procedure.

The advanced tuning options must be entered within 30 seconds after initialization completes. In addition the combination of dual rates and travel adjustments must result in a throw greater than 65% in order to enter the tuning modes.

Entering Servo Adjustment Mode

1. Lower the throttle stick to the lowest position.
2. Power ON the transmitter and activate throttle hold.
3. Install the flight battery on the helicopter frame, securing it with the hook and loop strap.
4. Connect the battery connector to the ESC.
5. After initialization is complete (indicated by a slow green flash), hold the left stick to the bottom left corner and the right stick to the bottom right corner as shown.

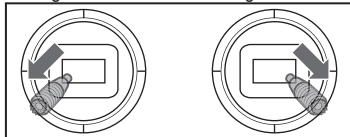

6. Servo Adjustment Mode is indicated by the swashplate servo jumping and then slowly moving back to center.
7. Release the sticks and proceed to the next step.

Adjusting the Servo Neutral Position

With the model in Servo Adjustment Mode, the control stick and gyro inputs are disabled and the servos are held in the neutral position. Check the position of the servo arms to verify they are perpendicular to the servos.

- If the arms are perpendicular to the servos, no adjustment is necessary. Exit Servo Adjustment Mode.
- If one or more servo arm is not perpendicular to the servos, continue the servo adjustment process.

While watching the swashplate servos, apply fore or aft cyclic and release. One of the servos will jump, indicating the selected servo. Apply fore or aft cyclic and release until the servo that needs to be adjusted is selected.

Once the servo you wish to adjust is selected, move the cyclic stick left or right to adjust the servo neutral position in the desired direction.

To reset the current servo to the default neutral position, hold the rudder stick full right for two seconds.

The range of adjustment is limited. If you are unable to adjust the servo arm to be perpendicular to the servo, you must reset the servo to the default neutral position, remove the servo arm and place it back onto the servo as close to perpendicular as possible. You may then adjust the servo neutral position using left or right cyclic stick.

Swashplate Leveling

Before saving your adjustments and exiting servo adjustment mode, verify the swashplate is level and both main rotor blades are at 0 degrees pitch.

If they are not, make linkage adjustments as necessary.

Saving the Servo Adjustments

1. Lower the throttle stick to the lowest position and release the sticks.
2. Move the tail rotor stick to the left and hold for four seconds to exit Servo Adjustment Mode. The servos will jump indicating a return to normal operation.
3. Release the tail rotor stick.
4. Perform the pre-flight checklist procedure before flying your model.

Control Input in Servo Adjustment Mode	Action in Servo Adjustment Mode
Fore/Aft Cyclic	Select Previous or Next Servo
Right/Left Cyclic	Increase or Decrease Sub Trim Adjustment
Right Tailrotor	Hold For Two Seconds; Neutral Position is Reset on Selected Servo
Left Tailrotor and Low throttle	Hold for Four Seconds; Exit Servo Adjustment mode

Calibration Procedure

If the helicopter is experiencing drift issues after completing the trim flight procedure, perform the following calibration. The calibration procedure may also be needed following crash repairs.

To perform the calibration procedure:

1. Ensure the surface used for calibration is level.
2. Power on the transmitter and helicopter, allowing them to initialize.
3. Turn Throttle Hold ON.
4. Ensure the main motor is disconnected.
5. Using a bubble level as shown below, level the helicopter by placing a shim under the landing skid.

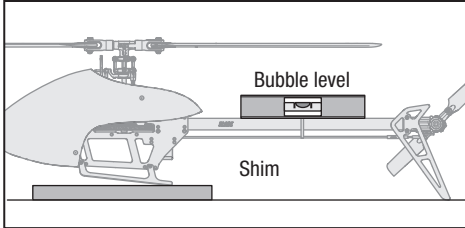

6. Hold the left stick to the bottom right corner, and the right stick to the upper left corner.

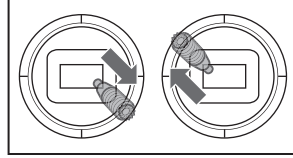

7. The LED on the Flight Controller will flash yellow while calibrating
Do not move the helicopter until the calibration is completed. If the LED displays a red LED an error has occurred. Begin the calibration procedure again, starting with step 1.
8. After the calibration is successfully completed, the receiver LED will blink green.

LED Indicator on FC	Indicator Description
Red Solid	FC6250HX waiting for receiver connection, system will not initialize until connected
Yellow Flash	Calibrating
Slow Green Flash	Ready to Fly
Red and Yellow Flash	Failsafe Active

Troubleshooting Guide

Problem	Possible Cause	Solution
Helicopter will not bind to the transmitter (during binding)	Low flight battery or transmitter battery voltage	Fully charge or replace the flight battery and/or transmitter batteries
	Transmitter is not in bind mode	Power on the transmitter while holding the Trainer/Bind switch. Hold the Trainer/Bind switch until binding is complete
	Transmitter too close to the helicopter during binding process	Power off the transmitter. Move the transmitter further away from the helicopter. Disconnect and reconnect the flight battery to the helicopter and follow binding instructions
Helicopter will not link to the transmitter (after binding)	Helicopter is bound to a different model memory (ModelMatch™ radios only)	Disconnect the flight battery. Select the correct model memory on the transmitter. Reconnect the flight battery
	Flight battery/Transmitter battery charge is too low	Replace or recharge batteries
Flight controller will not initialize	The helicopter was moved during initialization	Lay the helicopter on its side during initialization if windy
	The transmitter is powered off	Power on the transmitter
	Controls are not centered	Center elevator, aileron and rudder controls. Make sure the throttle is at idle
Helicopter will not respond to the throttle but responds to other controls	Throttle not at idle and/or throttle trim is too high	Lower the throttle stick and lower the throttle trim
	The transmitter is not in normal mode or throttle hold is on	Make sure the transmitter is in normal mode and throttle hold is off
	The motor is not connected to the ESC or the motor wires are damaged	Connect the motor wires to the ESC and check motor wires for damage
	Flight battery charge is too low	Replace or recharge flight battery
Helicopter power is lacking	Throttle channel is reversed	Reverse the throttle channel on the transmitter
	Flight battery has low voltage	Fully charge the flight battery
	Flight battery is old or damaged	Replace the flight battery
	Flight battery cells are unbalanced	Fully charge the flight battery, allowing the charger time to balance the cells
	Excessive current is being drawn through the BEC	Check all servos and the helicopter motor for damage
	Tail drive belt tension is not correct	See "Tail Belt Tension" section in this manual
Helicopter will not lift off	Main rotor head is not spinning in the correct direction	Make sure the main rotor head is spinning clockwise. Refer to the motor control test
	Transmitter settings are not correct	Check throttle and pitch curve settings and pitch control direction
	Flight battery has low voltage	Fully charge the flight battery
	Main rotor blades are installed backwards	Install the main rotor blades with the thicker side as the leading edge
The helicopter tail spins out of control	Rudder control and/or sensor direction reversed	Make sure the rudder control and the rudder sensor are operating in the correct direction
	Tail servo is damaged	Check the rudder servo for damage and replace if necessary
	Inadequate control arm throw	Check the rudder control arm for adequate travel and adjust if necessary
	Tail belt is too loose	Make sure the tail drive belt tension is adjusted correctly
The helicopter wobbles in flight	Cyclic gain is too high	Tuning options using forward programming are available under the "Advanced Settings" section in this manual
	Head speed is too low	Increase the helicopter's head speed via your transmitter settings and/or using a freshly charged flight pack
	Dampers are worn	Replace the main rotor head dampers

Exploded View

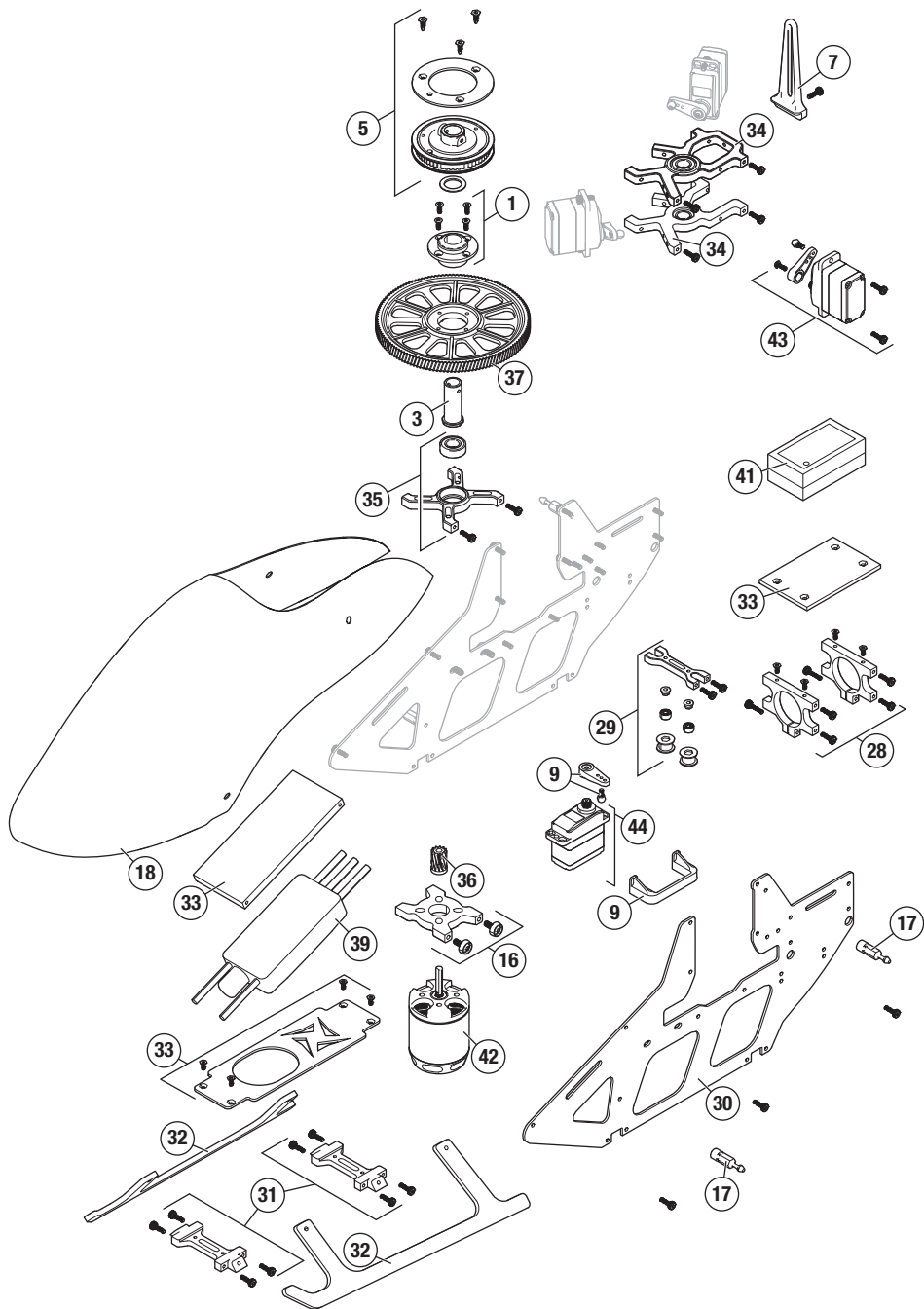

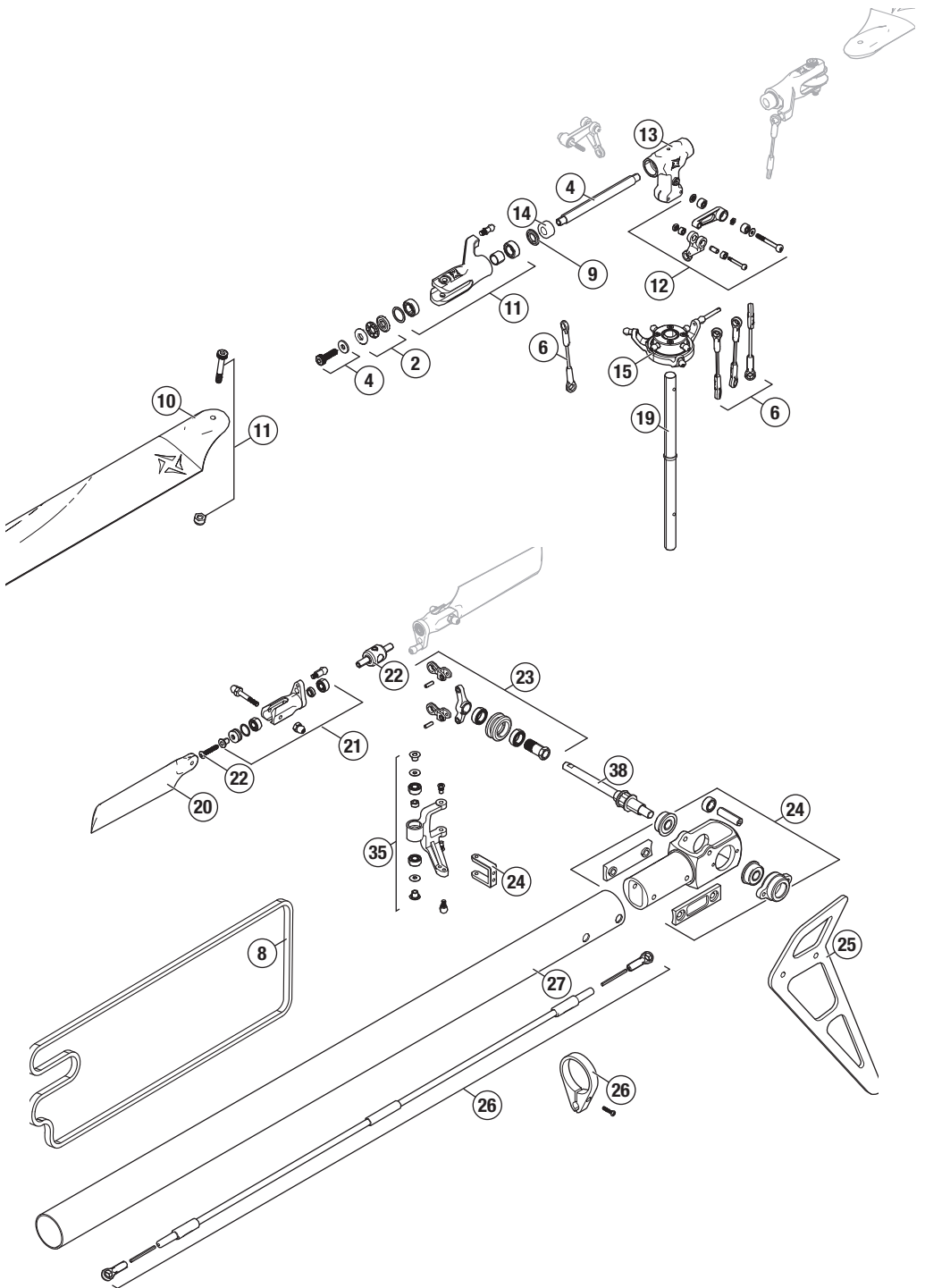

Parts List

#	Part #	Description
1	BLH1603	One-Way bearing Hub with One-Way Bearing
2	BLH1620	3x8x3.5 Thrust Bearing (2)
3	BLH1649	One-Way Bearing Shaft and Shim Set
4	BLH4705	Spindle Set (2): 360 CFX
5	BLH4710	Belt Drive Puller: 360 CFX
6	BLH4720	Linkage Set: 360 CFX
7	BLH4721	Anti-Rotation Bracket: 360 CFX
8	BLH4728	Tail Drive Belt: 360 CFX
9	BLH4831	Servo Arm, Linkage Balls, Tail Servo Mount
10	BLH5201	Fusion 350mm Main Blade
11	BLH5202	Main Grip Set (2): Fusion 360
12	BLH5203	Washout Mixing Arms: Fusion 360
13	BLH5204	Main Rotor Headblock: Fusion 36
14	BLH5205	Damper Set (2) 90 : Fusion 360
15	BLH5206	Swashplate: Fusion 360
16	BLH5207	Motor Mount: Fusion 360
17	BLH5208	Body Post Mounts (4): Fusion 36
18	BLH5209	Fusion 360 Painted Canopy
19	BLH5210	Main Shaft: Fusion 360
20	BLH5211	Fusion 65mm Tail Blade Set
21	BLH5212	Alu Tail Grip Set: Fusion 360
22	BLH5213	Tail Rotor Hub: Fusion 360

#	Part #	Description
23	BLH5214	Tail Pitch Slider: Fusion 360
24	BLH5215	Rear Tail Case: Fusion 360
25	BLH5216	Vertical Tail Fin: Fusion 360
26	BLH5217	Tail Rotor Pushro: Fusion 360
27	BLH5218	Tail Boom Set (2): Fusion 360
28	BLH5219	Tail Boom Clamp (2): Fusion 360
29	BLH5220	Tail Belt Guide: Fusion 360
30	BLH5221	Frame (1): Fusion 360
31	BLH5222	Gear Mount (2): Fusion 360
32	BLH5223	Landing Gear: Fusion 360
33	BLH5224	Carbon Plates: Fusion 360
34	BLH5225	Bear Block Set (3): Fusion 360
35	BLH5226	Tail Rotor Bellcrank: Fusion 360
36	BLH5232	Helical Pinion 12T
37	BLH5337	Helical Main Gear Black
38	BLH5336	Tail Shaft with Pulley
39	BLHHW60A	Blade Heli 60 A Brushless ESC
40	SPM4649T	DSMX Quad Race Receiver w/telemetry
41	SPMFC6250HX	Flight Controller
42	BLH4731	Brushless Out-Runner Motor, 1800Kv
43	SPMSH3055	H3055 M-T / U-S Micro Cyclic Servo
44	SPMSH3065	H3065 M-T / U-S Micro Tail Servo

Recommended Parts List

Part #	Description
SPMX18006S50	6S LiPo Battery, 1800mAh, 50C, iC3
SPMXC1000	Smart S1200 DC Charger, 1x200W

Part #	Description
SPMXC1010	Smart S2100 AC Charger, 2x100W
SPMXC10201	Smart 30-Amp Power Supply

Optional Parts List

Part #	Description
BLH5051	Brushless Motor, 3400Kv: 360 CF
BLH5230	10T Helical Pinion
BLH5231	11T Helical Pinion
SPMX18006S50	1800mAh 6S 22.2V 50C LiPo iC3

Part #	Description
SPMSP1040	Gear Set: H3050
SPMSP1041	Gear Set: H3060
SPMSP2052	Case Set: H3050, H3060

Ball Bearing Sizes

Description	Bearing Size
Main Grip Radial Bearings	9mm x 5mm x 3mm
Main Thrust Bearings	9mm x 4mm x 4mm
Washout Arm Pivot Bearings	5mm x 2mm x 2.5mm
Washout Arm Link Bearing	4mm x 1.5mm x 2mm
Main Shaft Bearing Blocks	12mm x 6mm x 4mm
Tail Belt Front Idler Pulley	5mm x 2mm x 2.5mm

Description	Bearing Size
Tail Belt Rear Idler Pulley	7mm x 4mm x 2.5mm
Tail Case Tail Shaft Bearings	F10mm x 4mm x 4mm
Tail Bellcrank Bearings	6mm x 3mm x 2.5mm
Tail Pitch Slider Bearings	8mm x 5mm x 2.5mm
Tail Grip Radial Bearings	6mm x 3mm x 5mm
Tail Grip Thrust Bearings	6mm x 2.5mm x 3mm

Limited Warranty

What this Warranty Covers

Horizon Hobby, LLC, (Horizon) warrants to the original purchaser that the product purchased (the "Product") will be free from defects in materials and workmanship at the date of purchase.

What is Not Covered

This warranty is not transferable and does not cover (i) cosmetic damage, (ii) damage due to acts of God, accident, misuse, abuse, negligence, commercial use, or due to improper use, installation, operation or maintenance, (iii) modification of or to any part of the Product, (iv) attempted service by anyone other than a Horizon Hobby authorized service center, (v) Product not purchased from an authorized Horizon dealer, (vi) Product not compliant with applicable technical regulations, or (vii) use that violates any applicable laws, rules, or regulations.

OTHER THAN THE EXPRESS WARRANTY ABOVE, HORIZON MAKES NO OTHER WARRANTY OR REPRESENTATION, AND HEREBY DISCLAIMS ANY AND ALL IMPLIED WARRANTIES, INCLUDING, WITHOUT LIMITATION, THE IMPLIED WARRANTIES OF NON-INFRINGEMENT, MERCHANTABILITY AND FITNESS FOR A PARTICULAR PURPOSE. THE PURCHASER ACKNOWLEDGES THAT THEY ALONE HAVE DETERMINED THAT THE PRODUCT WILL SUITABLY MEET THE REQUIREMENTS OF THE PURCHASER'S INTENDED USE.

Purchaser's Remedy

Horizon's sole obligation and purchaser's sole and exclusive remedy shall be that Horizon will, at its option, either (i) service, or (ii) replace, any Product determined by Horizon to be defective. Horizon reserves the right to inspect any and all Product(s) involved in a warranty claim. Service or replacement decisions are at the sole discretion of Horizon. Proof of purchase is required for all warranty claims. SERVICE OR REPLACEMENT AS PROVIDED UNDER THIS WARRANTY IS THE PURCHASER'S SOLE AND EXCLUSIVE REMEDY.

Limitation of Liability

HORIZON SHALL NOT BE LIABLE FOR SPECIAL, INDIRECT, INCIDENTAL OR CONSEQUENTIAL DAMAGES, LOSS OF PROFITS OR PRODUCTION OR COMMERCIAL LOSS IN ANY WAY, REGARDLESS OF WHETHER SUCH CLAIM IS BASED IN CONTRACT, WARRANTY, TORT, NEGLIGENCE, STRICT LIABILITY OR ANY OTHER THEORY OF LIABILITY, EVEN IF HORIZON HAS BEEN ADVISED OF THE POSSIBILITY OF SUCH DAMAGES. Further, in no event shall the liability of Horizon exceed the individual price of the Product on which liability is asserted. As Horizon has no control over use, setup, final assembly, modification or misuse, no liability shall be assumed nor accepted for any resulting damage or injury. By the act of use, setup or assembly, the user accepts all resulting liability. If you as the purchaser or user are not prepared to accept the liability associated with the use of the Product, purchaser is advised to return the Product immediately in new and unused condition to the place of purchase.

Law

These terms are governed by Illinois law (without regard to conflict of law principals). This warranty gives you specific legal rights, and you may also have other rights which vary from state to state. Horizon reserves the right to change or modify this warranty at any time without notice.

WARRANTY SERVICES

Questions, Assistance, and Services

Your local hobby store and/or place of purchase cannot provide warranty support or service. Once assembly, setup or use of the Product has been started, you must contact your local distributor or Horizon directly. This will enable Horizon to better answer your

questions and service you in the event that you may need any assistance. For questions or assistance, please visit our website at www.horizonhobby.com, submit a Product Support Inquiry, or call the toll free telephone number referenced in the Warranty and Service Contact Information section to speak with a Product Support representative.

Inspection or Services

If this Product needs to be inspected or serviced and is compliant in the country you live and use the Product in, please use the Horizon Online Service Request submission process found on our website or call Horizon to obtain a Return Merchandise Authorization (RMA) number. Pack the Product securely using a shipping carton. Please note that original boxes may be included, but are not designed to withstand the rigors of shipping without additional protection. Ship via a carrier that provides tracking and insurance for lost or damaged parcels, as Horizon is not responsible for merchandise until it arrives and is accepted at our facility. An Online Service Request is available at http://www.horizonhobby.com/content/service-center_render-service-center. If you do not have internet access, please contact Horizon Product Support to obtain a RMA number along with instructions for submitting your product for service. When calling Horizon, you will be asked to provide your complete name, street address, email address and phone number where you can be reached during business hours. When sending product into Horizon, please include your RMA number, a list of the included items, and a brief summary of the problem. A copy of your original sales receipt must be included for warranty consideration. Be sure your name, address, and RMA number are clearly written on the outside of the shipping carton.

NOTICE: Do not ship LiPo batteries to Horizon. If you have any issue with a LiPo battery, please contact the appropriate Horizon Product Support office.

Warranty Requirements

For Warranty consideration, you must include your original sales receipt verifying the proof-of-purchase date. Provided warranty conditions have been met, your Product will be serviced or replaced free of charge. Service or replacement decisions are at the sole discretion of Horizon.

Non-Warranty Service

Should your service not be covered by warranty, service will be completed and payment will be required without notification or estimate of the expense unless the expense exceeds 50% of the retail purchase cost. By submitting the item for service you are agreeing to payment of the service without notification. Service estimates are available upon request. You must include this request with your item submitted for service. Non-warranty service estimates will be billed a minimum of ½ hour of labor. In addition you will be billed for return freight. Horizon accepts money orders and cashier's checks, as well as Visa, MasterCard, American Express, and Discover cards. By submitting any item to Horizon for service, you are agreeing to Horizon's Terms and Conditions found on our website http://www.horizonhobby.com/content/service-center_render-service-center.

ATTENTION: Horizon service is limited to Product compliant in the country of use and ownership. If received, a non-compliant Product will not be serviced. Further, the sender will be responsible for arranging return shipment of the un-serviced Product, through a carrier of the sender's choice and at the sender's expense. Horizon will hold non-compliant Product for a period of 60 days from notification, after which it will be discarded.

Warranty and Service Contact Information

Country of Purchase	Horizon Hobby	Contact Information	Address
United States of America	Horizon Service Center (Repairs and Repair Requests)	servicecenter.horizonhobby.com/RequestForm/	2904 Research Rd Champaign, Illinois, 61822 USA
	Horizon Product Support (Product Technical Assistance)	productsupport@horizonhobby.com 877-504-0233	
	Sales	websales@horizonhobby.com 800-338-4639	
European Union	Horizon Technischer Service Sales: Horizon Hobby GmbH	service@horizonhobby.eu +49 (0) 4121 2655 100	Hanskampring 9 D 22885 Barsbüttel, Germany

FCC Information

FCC ID: BRWAR4649T

Contains IC: 6157A-AR4649T

FCC Information

This device complies with part 15 of the FCC rules. Operation is subject to the following two conditions: (1) This device may not cause harmful interference, and (2) this device must accept any interference received,

including interference that may cause undesired operation.

CAUTION: Changes or modifications not expressly approved by the party responsible for compliance could void the user's authority to operate the equipment.

This product contains a radio transmitter with wireless technology which has been tested and found to be compliant with the applicable regulations governing a radio transmitter in the 2.400GHz to 2.4835GHz frequency range.

Supplier's Declaration of Conformity

Fusion 360 – BLH5250

FC This device complies with part 15 of the FCC Rules. Operation is subject to the following two conditions: (1) This device may not cause harmful interference, and (2) this device must accept any interference received, including interference that may cause undesired operation.

CAUTION: changes or modifications not expressly approved by the party responsible for compliance could void the user's authority to operate the equipment.

NOTE: This equipment has been tested and found to comply with the limits for a Class B digital device, pursuant to part 15 of the FCC Rules. These limits are designed to provide reasonable protection against harmful interference in a residential installation. This equipment generates, uses and can radiate radio frequency energy and, if not installed and used in accordance with the instructions, may cause harmful interference to radio communications. However, there is no guarantee that interference will not occur in a particular installation. If this equipment does cause harmful interference to radio or television reception, which can be determined by turning the equipment off and on, the user is encouraged to try to correct the interference by one or more of the following measures:

- Reorient or relocate the receiving antenna.
- Increase the separation between the equipment and receiver.
- Connect the equipment into an outlet on a circuit different from that to which the receiver is connected.
- Consult the dealer or an experienced radio/TV technician for help.

Horizon Hobby, LLC
2904 Research Rd.,
Champaign, IL 61822
Email: compliance@horizonhobby.com
Web: HorizonHobby.com

IC Information

IC: 6157A-AR4649T

This device complies with Industry Canada licence-exempt RSS standard(s). Operation is subject to the following two conditions: (1) this device may not cause interference, and

(2) this device must accept any interference, including interference that may cause undesired operation of the device.”

Compliance Information for the European Union



EU Compliance Statement: BLH5250

Horizon Hobby, LLC hereby declares that this product is in compliance with the essential requirements and other relevant provisions of the RED and EMC Directives.

A copy of the EU Declaration of Conformity is available online at: <http://www.horizonhobby.com/content/support-render-compliance>.

Instructions for disposal of WEEE by users in the European Union



This product must not be disposed of with other waste. Instead, it is the user's responsibility to dispose of their waste equipment by handing it over to a designated collections point for the recycling of waste electrical and electronic equipment. The separate collection and recycling of your

waste equipment at the time of disposal will help to conserve natural resources and make sure that it is recycled in a manner that protects human health and the environment. For more information about where you can drop off your waste equipment for recycling, please contact your local city office, your household waste disposal service or where you purchased the product.



E328



©2019 Horizon Hobby, LLC.

Blade, the Blade logo, Fusion, DSM, DSM2, DSMX, Bind-N-Fly, IC3, EC3, AirWare, SAFE, BNF, the BNF logo, ModelMatch and the Horizon Hobby logo are trademarks or registered trademarks of Horizon Hobby, LLC.

The Spektrum trademark is used with permission of Bachmann Industries, Inc.

Futaba is a registered trademark of Futaba Denshi Kogyo Kabushiki Kaisha Corporation of Japan.

All other trademarks, service marks or logos are property of their respective owners. US D774,933.

Created 03/19

BLH5250

58420