



SAAB AJ 37 Viggen „Attack version”

Historie

CZ

SAAB 37 Viggen je letoun, který předběhl svou dobu. Neortodoxní řešení, zvolená jeho konstruktéry, nejen umožnily Viggenu splnit požadavky na něj kladené, ale v některých parametrech je předčil. Švédské letectvo objednalo Viggen v několika verzích, s tím, že základní provedení letounu tvořilo univerzální platformu, která doplněná o speciální vybavení umožňovala použití v několika rolích.

První ze sedmi stavěných prototypů vzlétl 8. února 1967, řízen pilotem E. Dalsrömem. Pohon zajišťoval motor Volvo RM8, licenční civilní motor Pratt & Whitney JT8D doplněný o přídavné spalování a obraceče tahu. To, stejně jako koncepce dvojíh delta křídel přispívalo k vynikajícím vlastnostem Viggenu při startech a přistáních na malých přistávacích plochách. Pro lepší manipulaci s letouny po přistání umístění do hangárů či jejich lepšímu zamaskování při operacích z nestandardních ploch dostal Viggen sklopnou svislou ocasní plochu. Elektronické vybavení bylo ve své době jedno z nejlepších na světě, Viggen byl první stroj se zabudovaným počítačem s integrovanými obvody. Do výzbroje švédského letectva byla jako první zařazena verze AJ 37 Viggen, kterou postupně následovaly verze SK 37 - dvoumístný cvičný stíhací letoun, SF 37 - průzkumná verze s fotografickými přístroji v upravené přídi, SH 37 - protilodní verze s odlišným elektronickým vybavením a protilodní výzbrojí. Po cca deseti letech od zařazení první verze byla vyrobena druhá generace Viggenu, stíhací verze JA 37. Ta dostala modernizované elektronické vybavení a silnější motor v nepatrně prodlouženém trupu. Modernější elektronické vybavení dostaly i starší verze, přestavbou vznikaly stroje AJS 37, případně ASFS a ASHS 37. Část dvoumístných cvičných strojů byla přestavěna na verzi pro výcvik elektronického boje SK 37E. Švédské letectvo vyřadilo poslední Viggenu v roce 2007. Export Viggenu se nezdařil, většinou z politických důvodů. Mezi největší zájemce patřila např. Indie, ale zájem projevovaly i skandinávské země či Japonsko.

délka: 16,30 m, rozpětí: 10,60 m, max. rychlost: 2145 km/h, dolet standardní: 1000 km/maximální: 2000 km, dostup: 18 300 m, rychlost stoupání: 100 m/s

History

GB

The SAAB AJ 37 Viggen was an aircraft ahead of its time. Its designers used an unorthodox construction which enabled the plane to meet all requirements which had been laid on it and in some parameters even surpass them. The Swedish Air Force ordered several various versions of the Viggen jet fighter, its basic design formed an universal platform which, using a specialized equipment, enabled the plane to be used for different roles.

The first of seven prototypes took off for its maiden flight on February 8, 1967 with E. Dalsröm at the controls. The aircraft was powered by Volvo RM8 turbofan, a licence-built variant of Pratt & Whitney JT8D with an afterburner and thrust-reverser which, in addition to a double-delta wing design, enhanced the aircraft's performance during the take-offs and landings on short airstrips. The tailfin was designed as foldable to make it easier to store in hangars, it also helped with handling the aircraft after the landing and with hiding at the emergency airstrips. The avionics of the type was one of the best in the world in the time, Viggen was the first type to be equipped with a computer with integrated circuits.

The first version of the Viggen which saw service with the Flygvapnet was the AJ 37 strike fighter, followed consequently by the SK 37 two-seat trainer, SF 37 reconnaissance version with cameras in redesigned nose section and anti-shiping SH 37 with different avionics and equipped with anti-shiping weapons. Ten years after the first version of the SAAB had entered service, a second generation of the Viggen came into being, which was the JA 37 fighter version. More modern avionics was used and also a more powerful engine in a slightly longer fuselage. The earlier versions became to be equipped with the modernised avionics too and this way the AJS 37, respectively ASFS and ASHS 37 versions were created. Some of the two seat airframes were converted to the SK 37 E electronic warfare trainers.

The last of the Viggens were phased out in 2007. Mainly for political reasons, no Viggen has ever been exported to another countries, although India, Japan and Scandinavian countries showed some interest in the type.

Lenght: 16,30 m, Wingspan: 10,60 m, Max. speed: 2145 km/h, Standard Range: 1000 km/ Max. Range: 2000 km, Ceiling: 18 300 m, Rate of Climb: 100 m/s

KIT PARTS

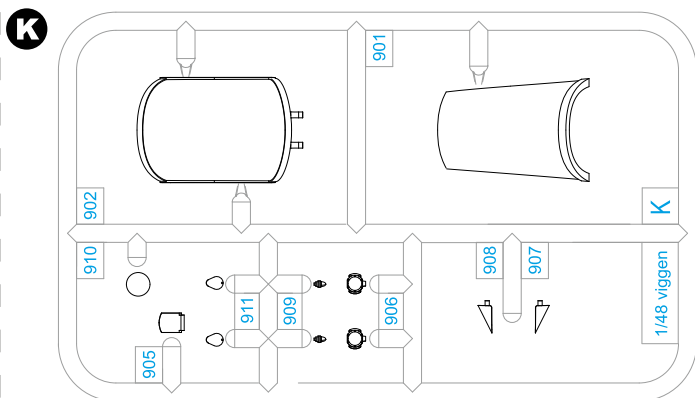
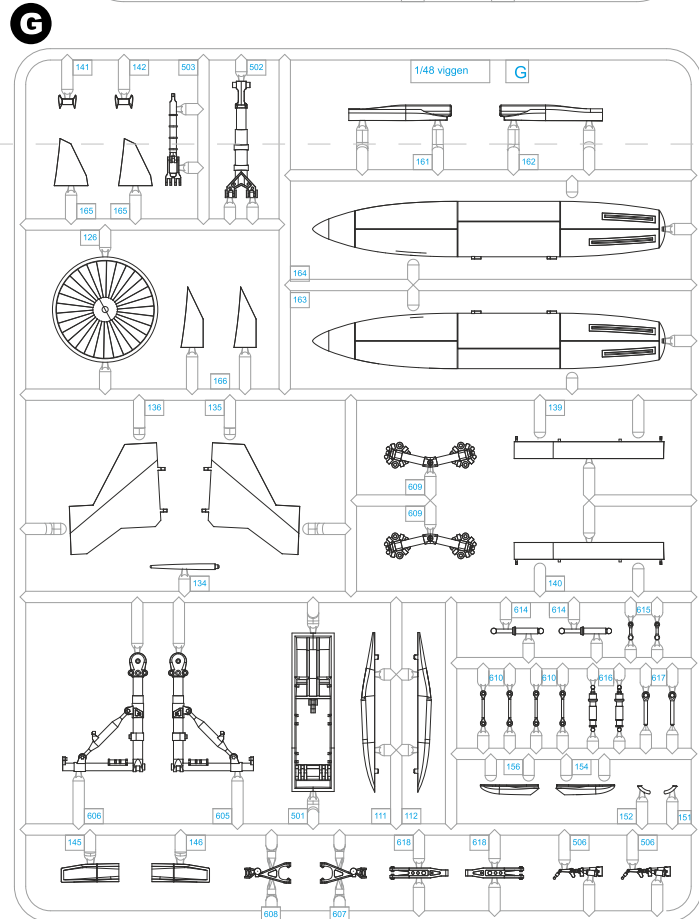
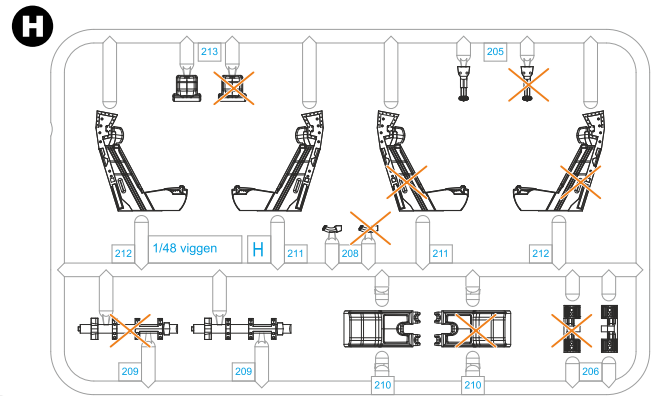
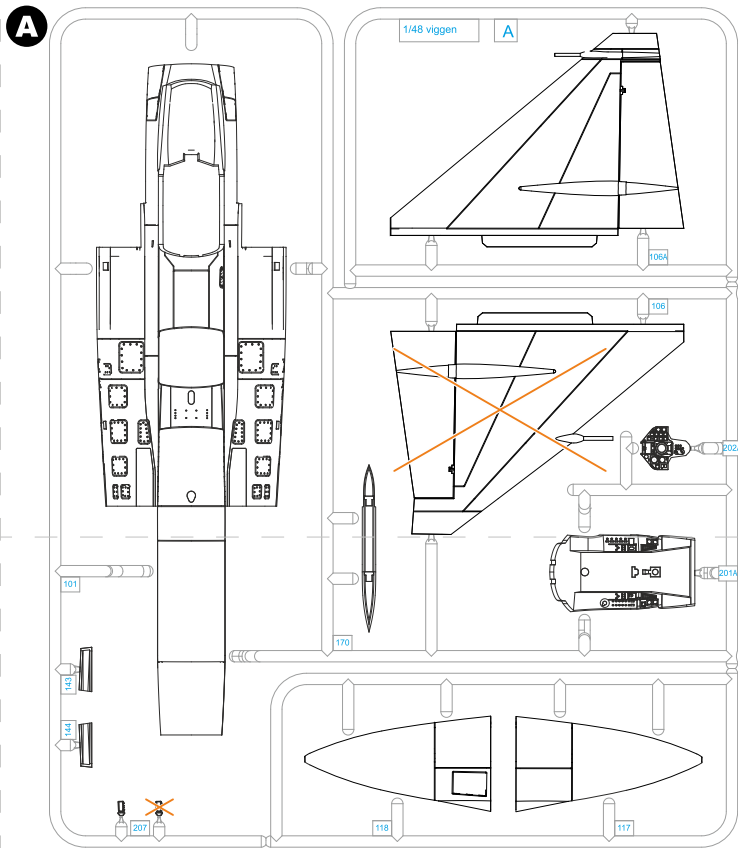
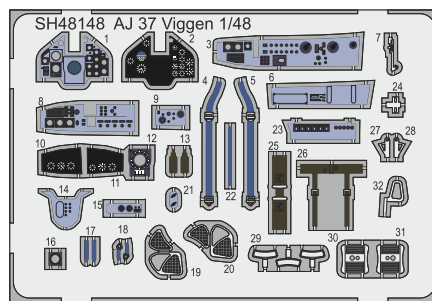

Photo-Etched Parts PE1-PE32



A	Červená/ RED	H3/C3
B	Žlutá/ YELLOW	H4/C4
C	Černá/ BLACK	H12/C33
D	Ocel/ STEEL	H18/C28
E	Zelená/ BRIGHT GREEN	H26/C66
F	Opálený kov/ BURNT IRON	H76/C61

G	Černá pneum./ TIRE BLACK	H77/C137
H	Šedá/ GREY	H308
I	Sv. zelená/ LIGHT GREEN	H319
J	Sv. šedá/ LIGHT GREY	H338
K	Tmavý kov/ DARK IRON	MC214
L	Hliník/ ALUMINIUM	MC218

Barvy GUNZE/ GUNZE Colour No.

SYMBOLS

? MOŽNOST VOLBY
OPTIONAL
NACH BELIEBEN
OPTION

🔹 POUŽÍT KYANOAKRYLÁTOVÉ LEPIDLO
INSTANT CYANOACRYLATE GLUE
ZYANOAKRYLÁTKLEBER
ADHÉSIF CYANOACRYLAT

↶ OHNOUT
BEND
BIEGEN
COURBER

🖐️ ZHOTOVIT NOVÉ
SCRATCH BUILD
FERTIGSTELLEN
ACHEVER

✂️ ŘEZAT/VRTAT
CUT OFF/DRILL
ENTFERNEN
DETACHER

A NATRÍT
COLOUR
FARBEN
PEINDRE
GSI colours code

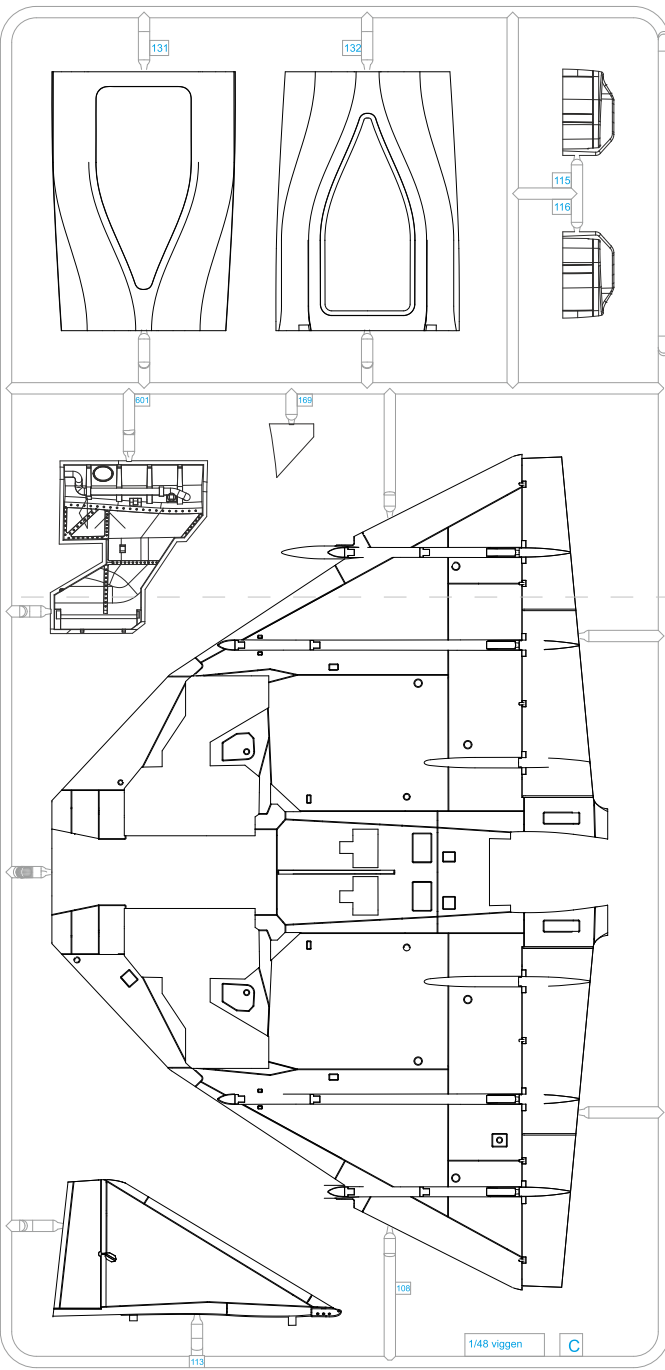
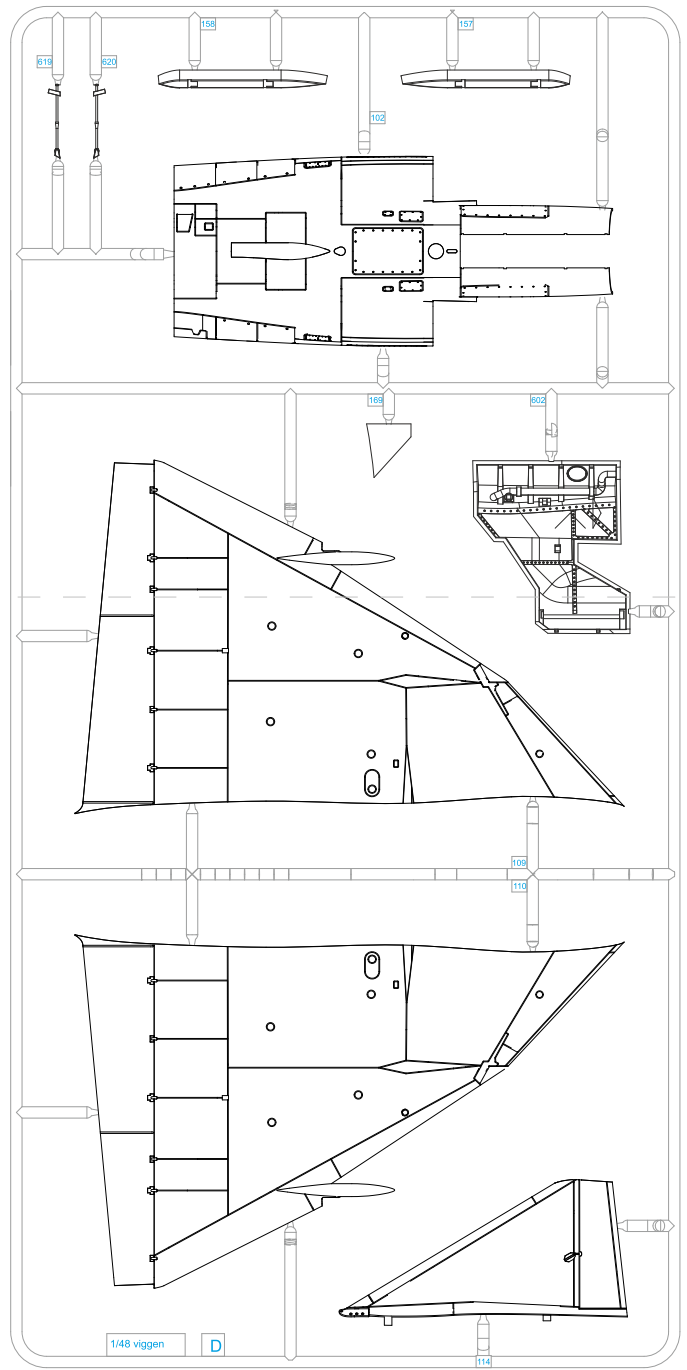
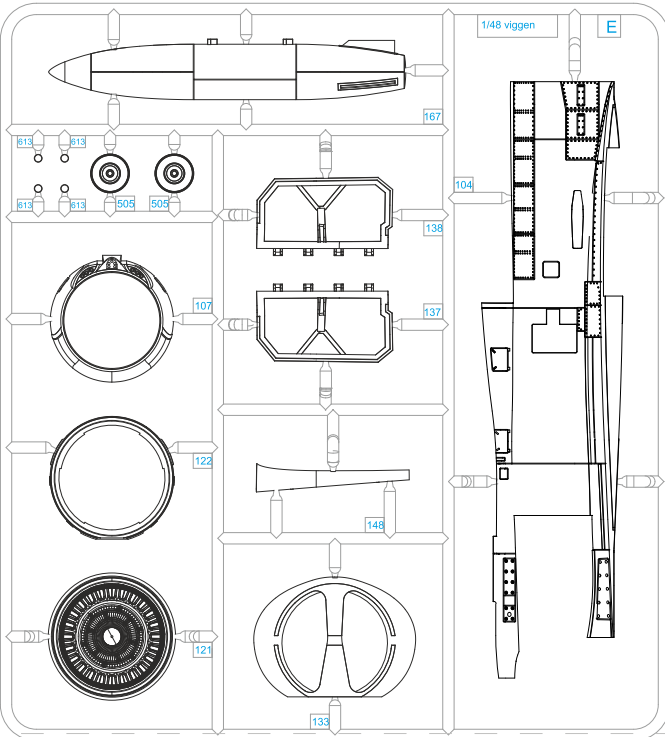
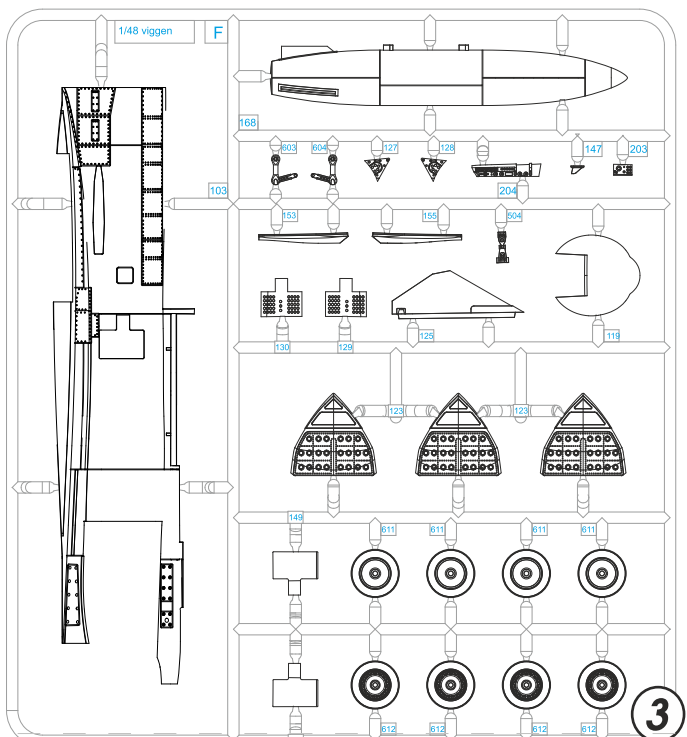
C**D****E****F****3**

ASSEMBLY

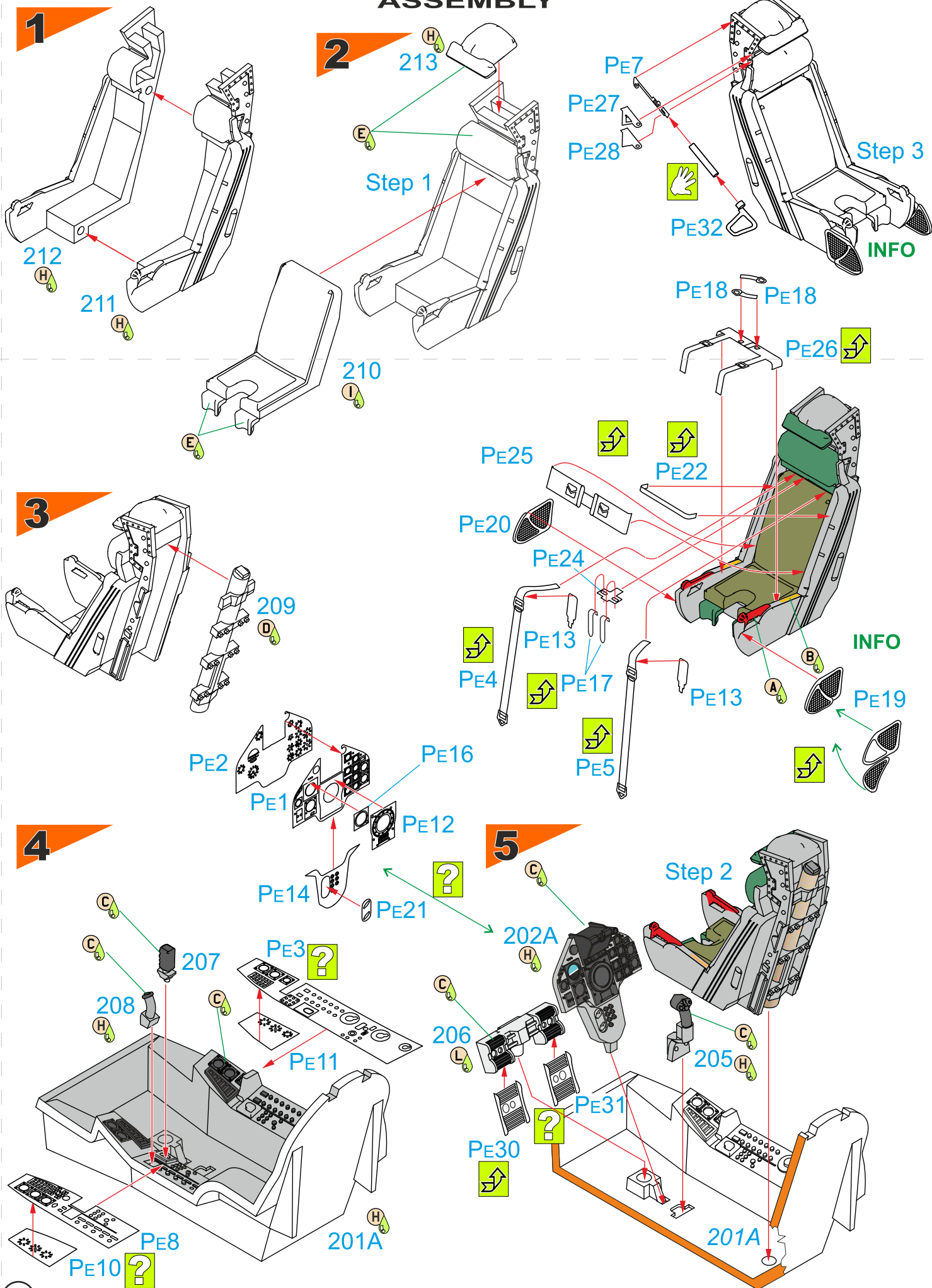

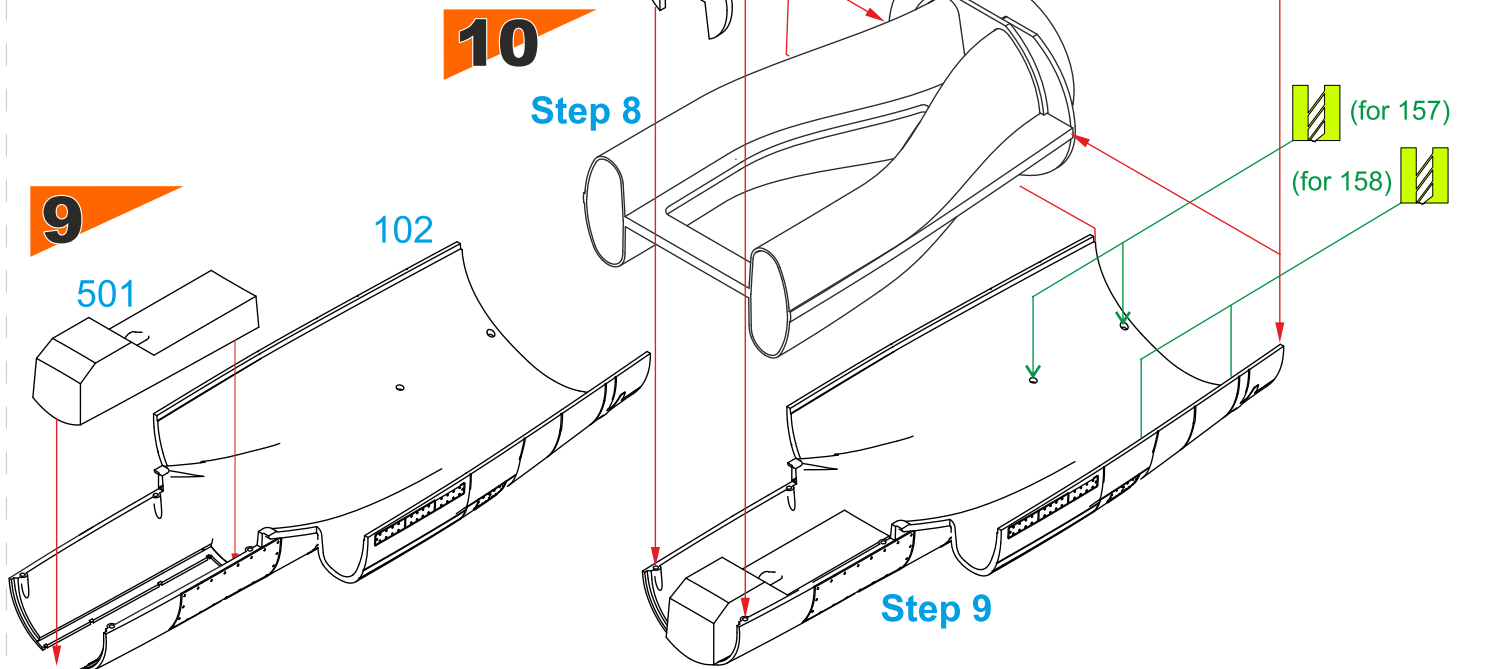
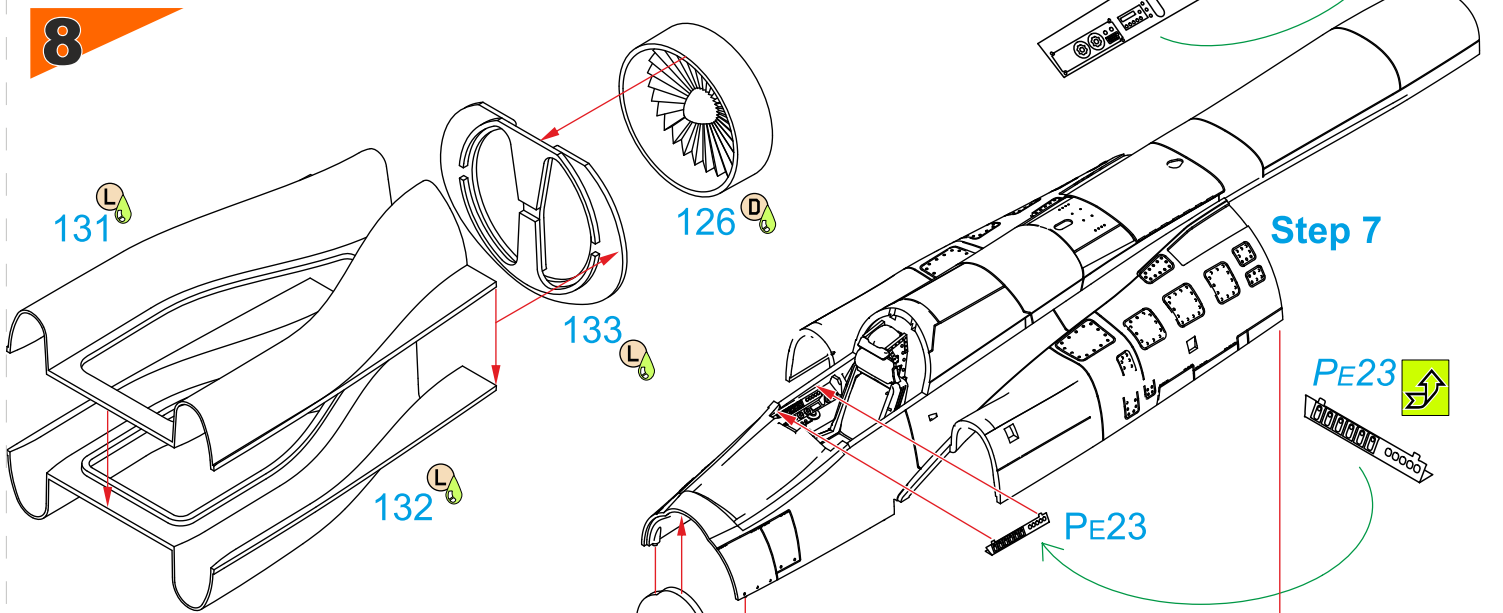
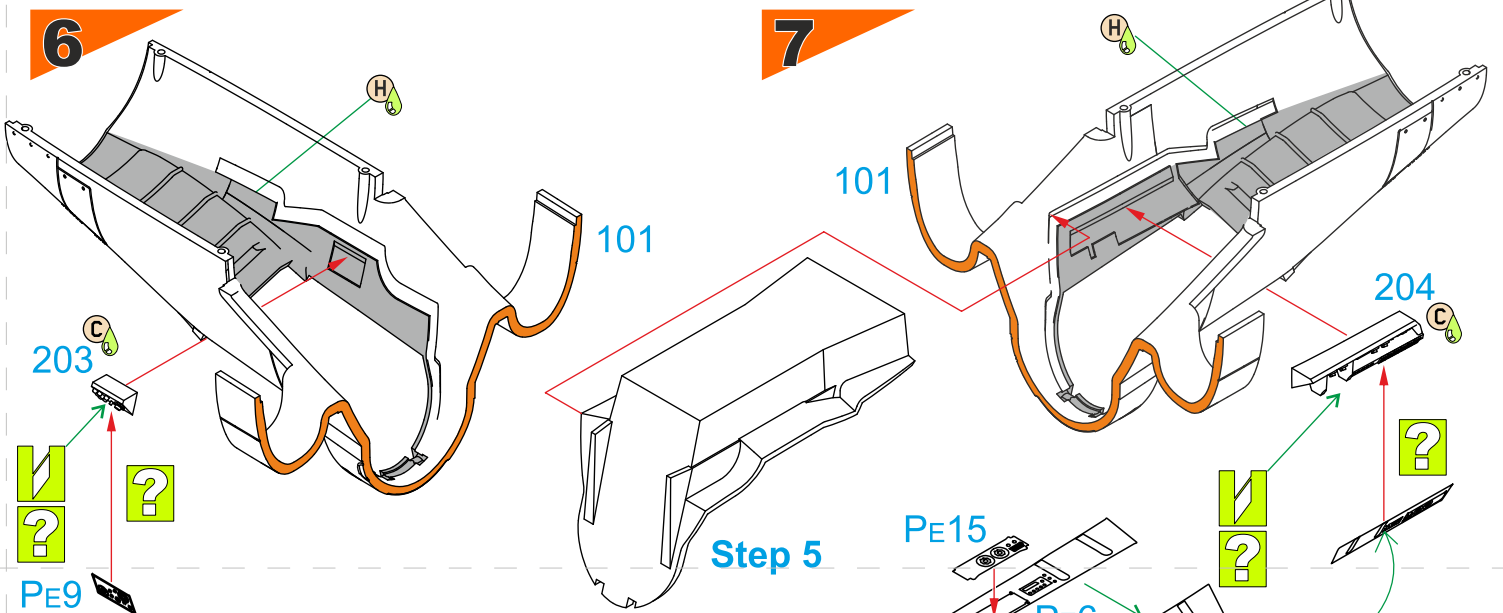

11

INFO
121-orientation

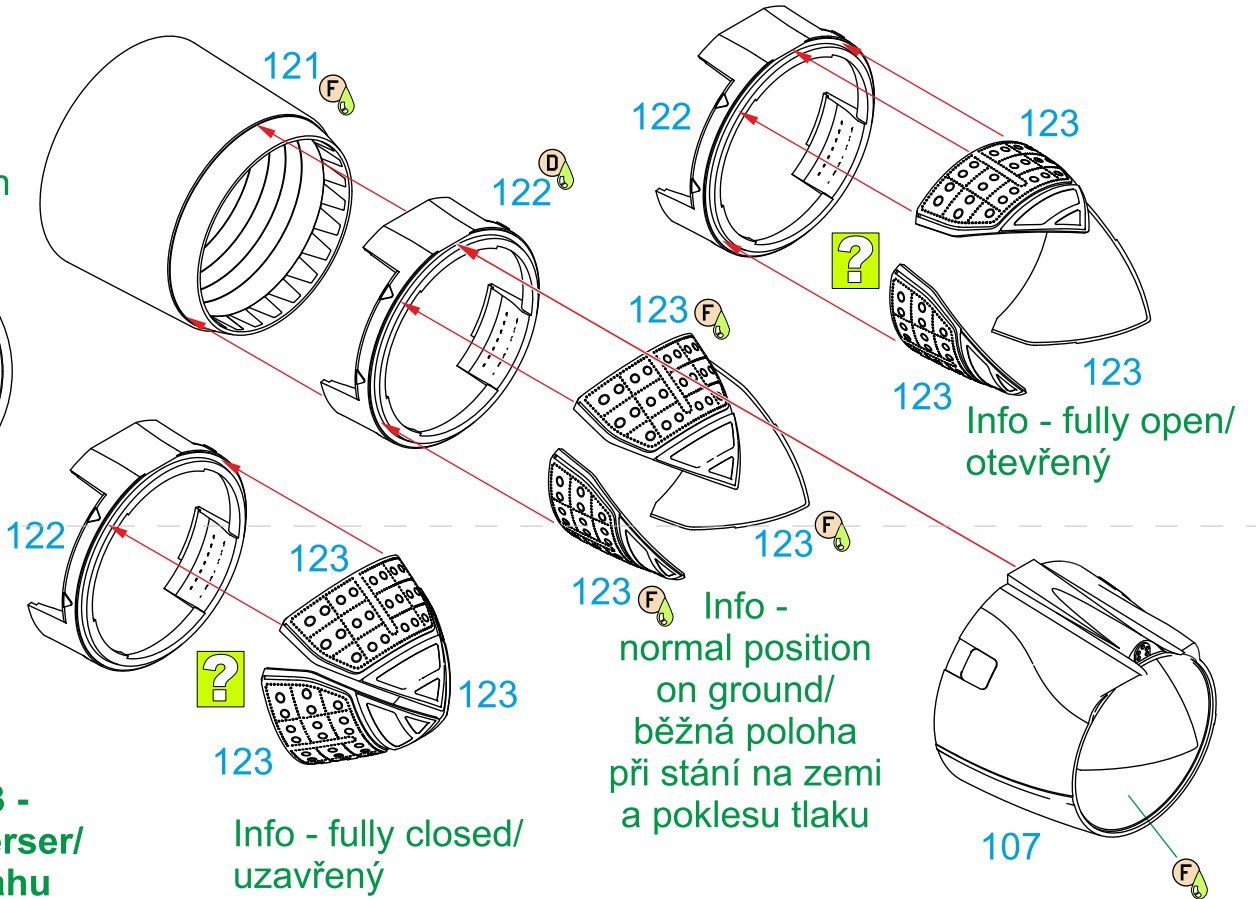
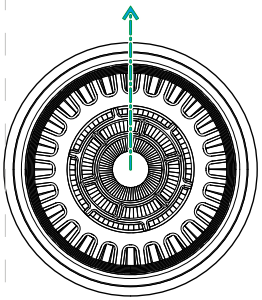

Info -
parts 123 -
Thrust Reverser/
obraceč tahu

Info - fully closed/
uzavřený

Info -
normal position
on ground/
běžná poloha
při stání na zemi
a poklesu tlaku

Info - fully open/
otevřený

12

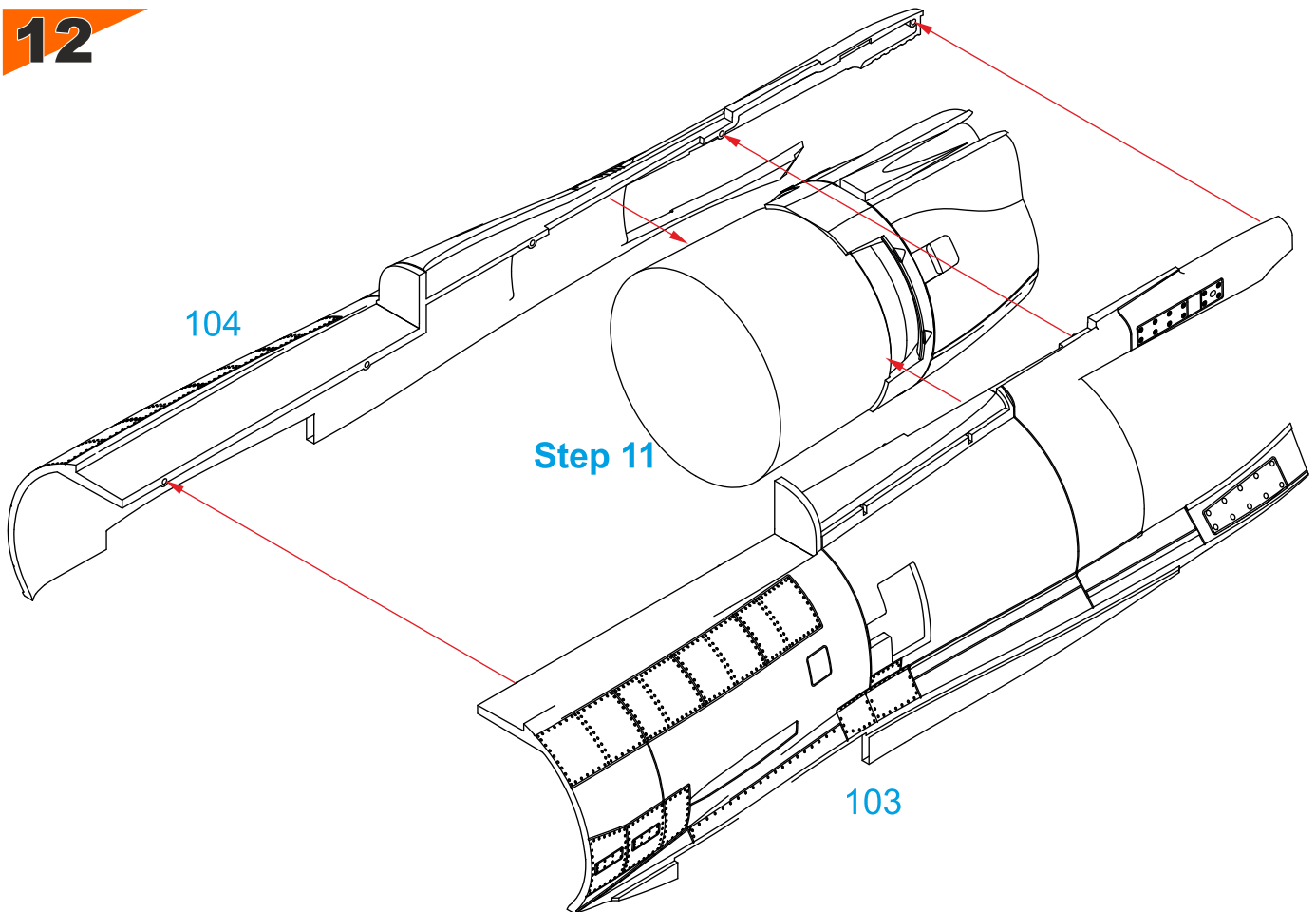

Step 11

13

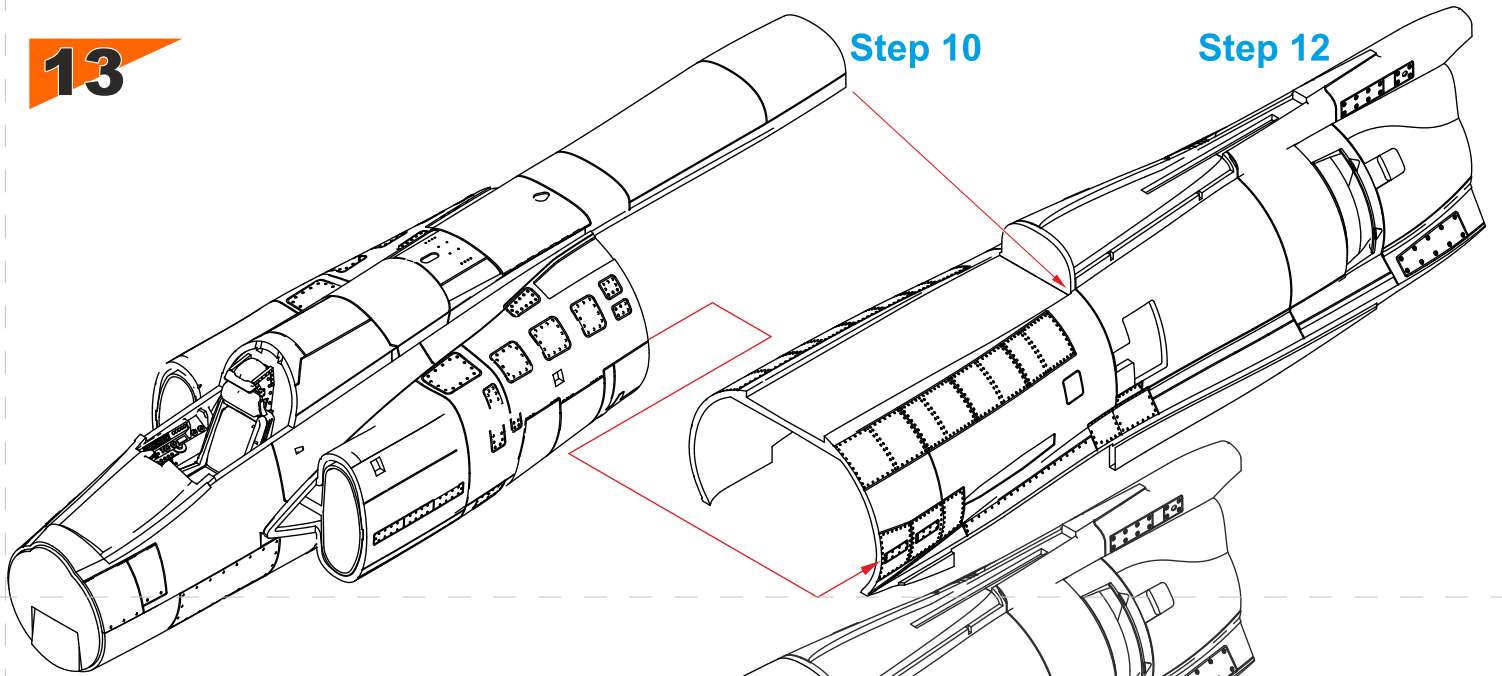

14

Step 13

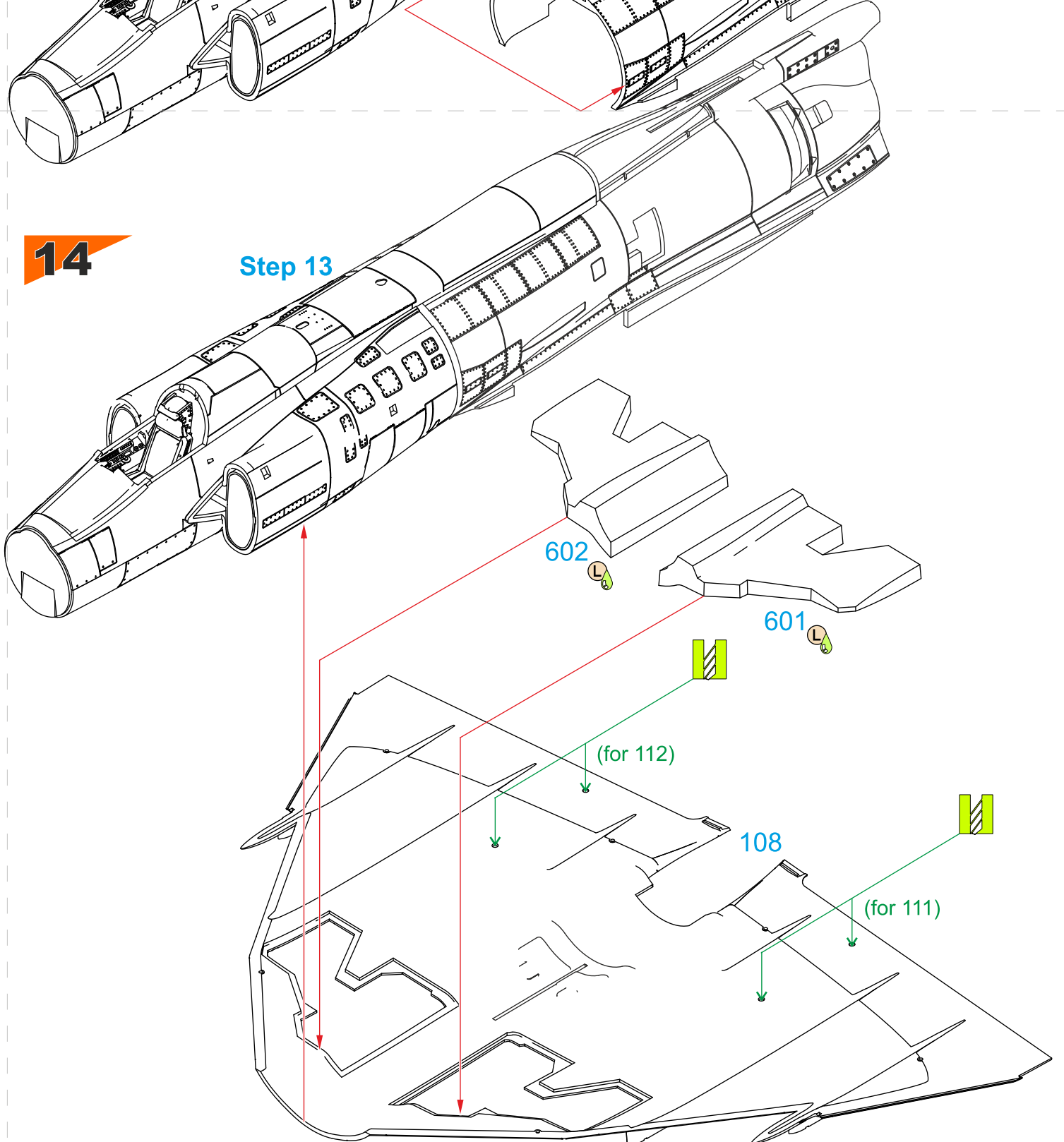

15

The model is balanced to correctly stand on its main landing gear. However, if you plan to add aftermarket equipment, it is a good idea to add some ballast in the nose to avoid model becoming a tailsitter.

Model by měl stát bez dovážení na svém podvozku, nicméně chcete-li na něj přidat dodatečnou výzbroj, bude dobré přidat zátěž do špičky trupu, aby model nebyl „těžký na ocas“ a nepadal na zadní část..

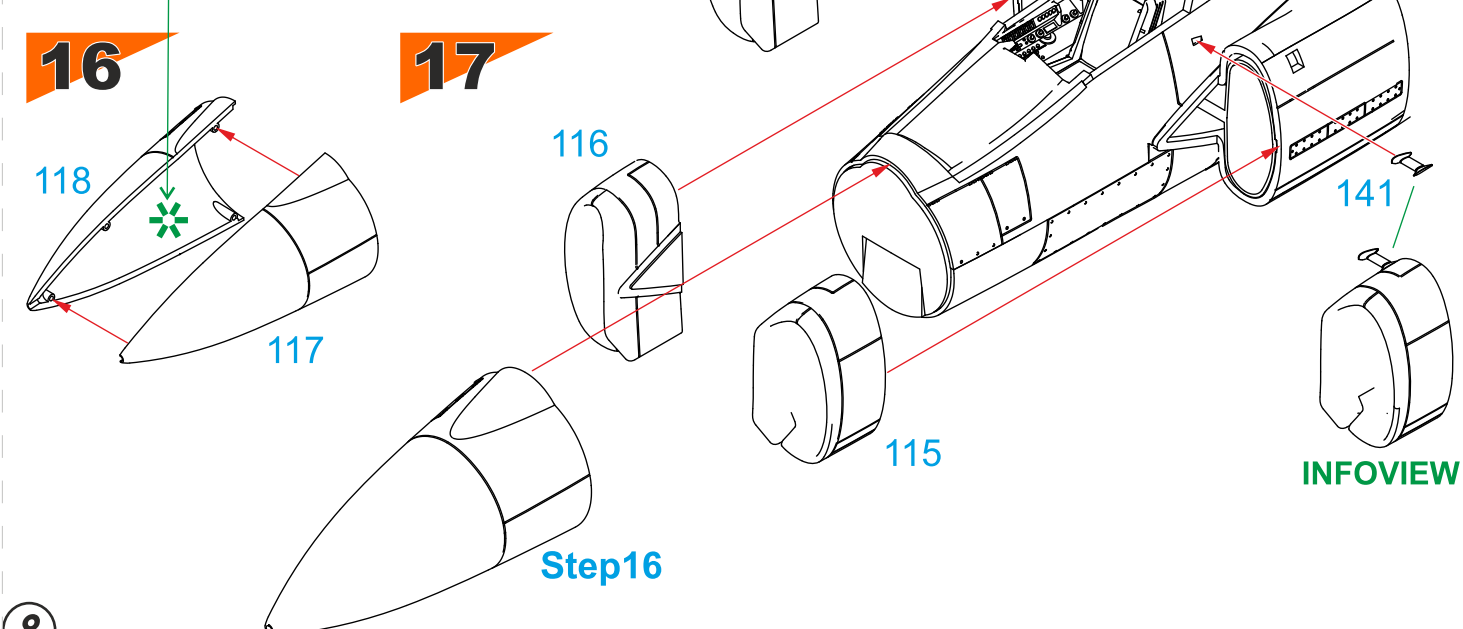
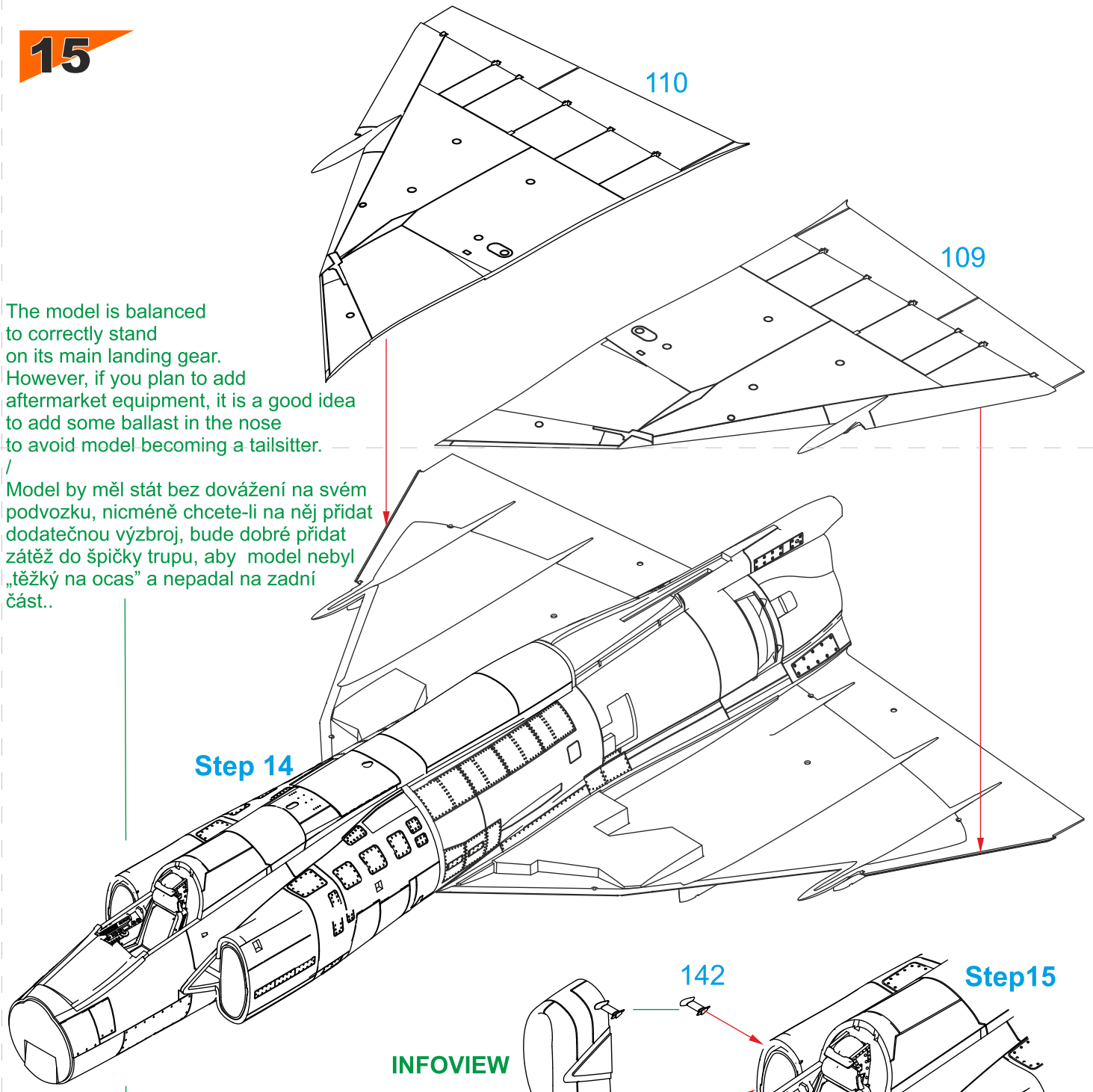

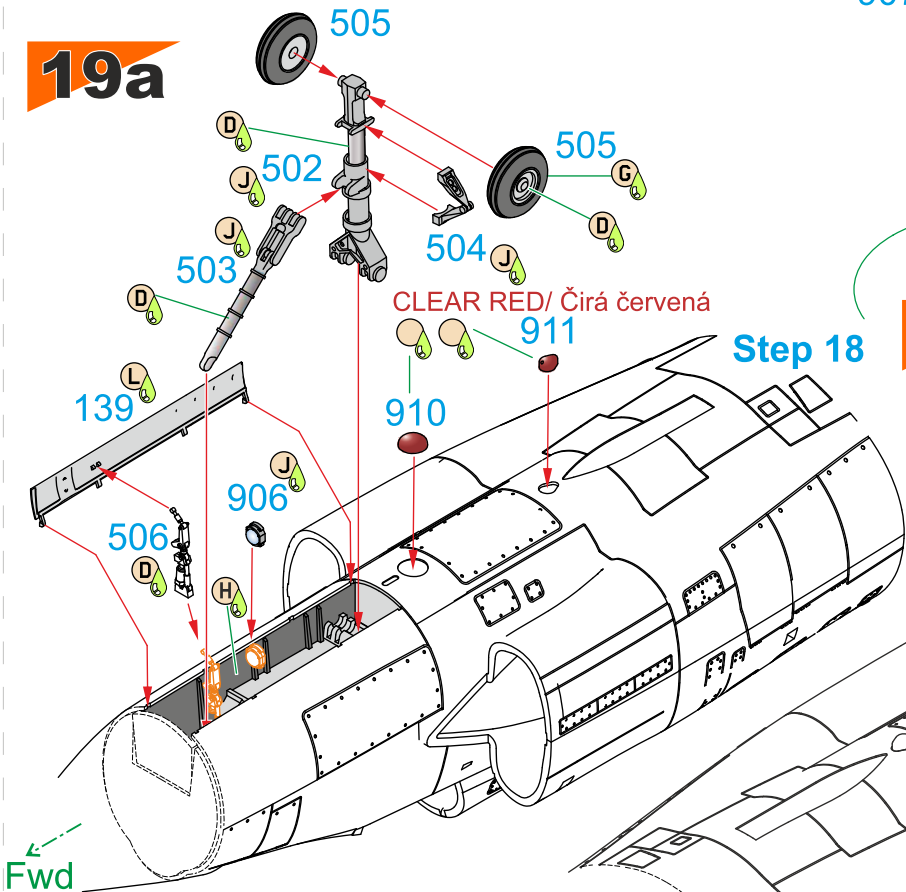
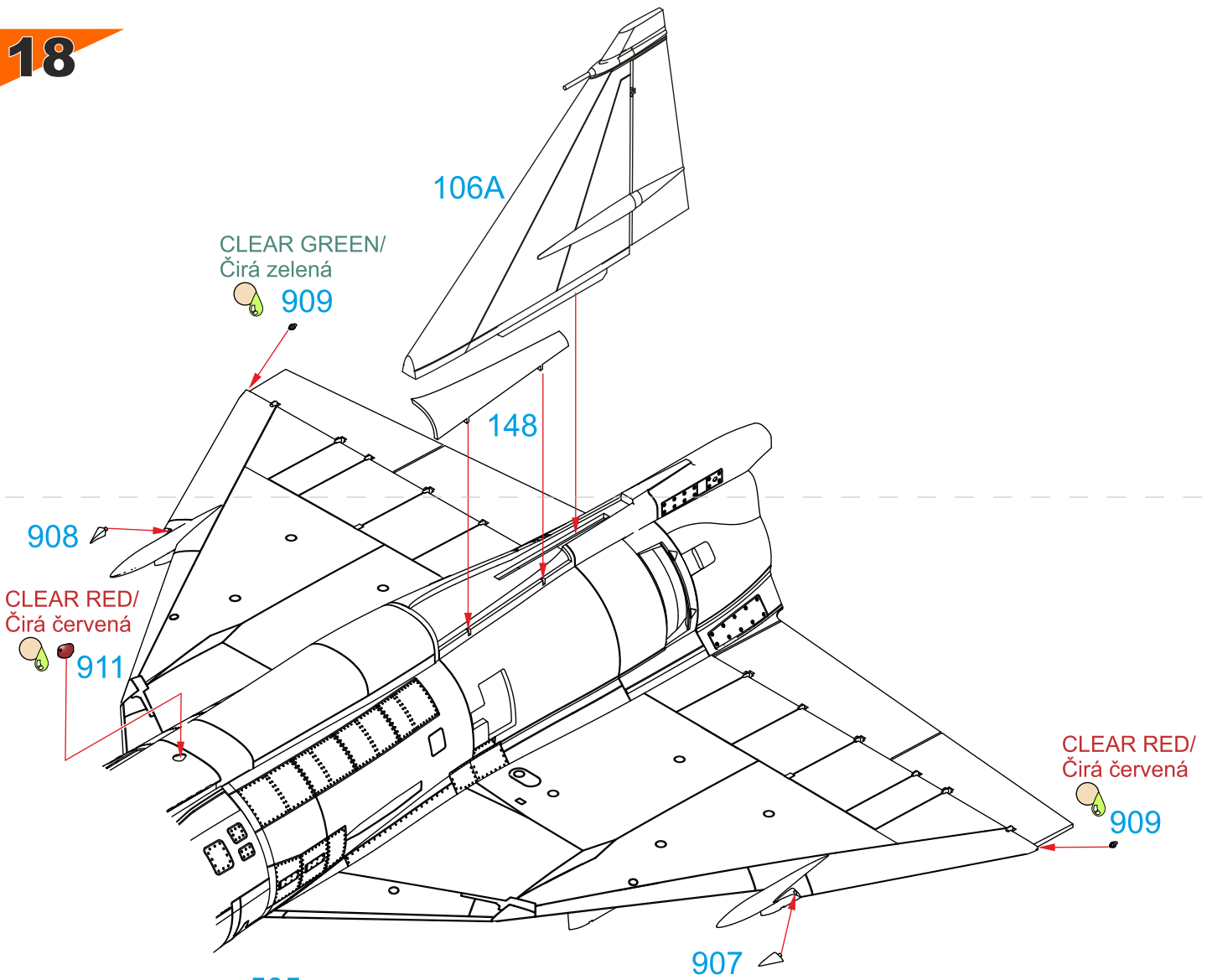

Step 18

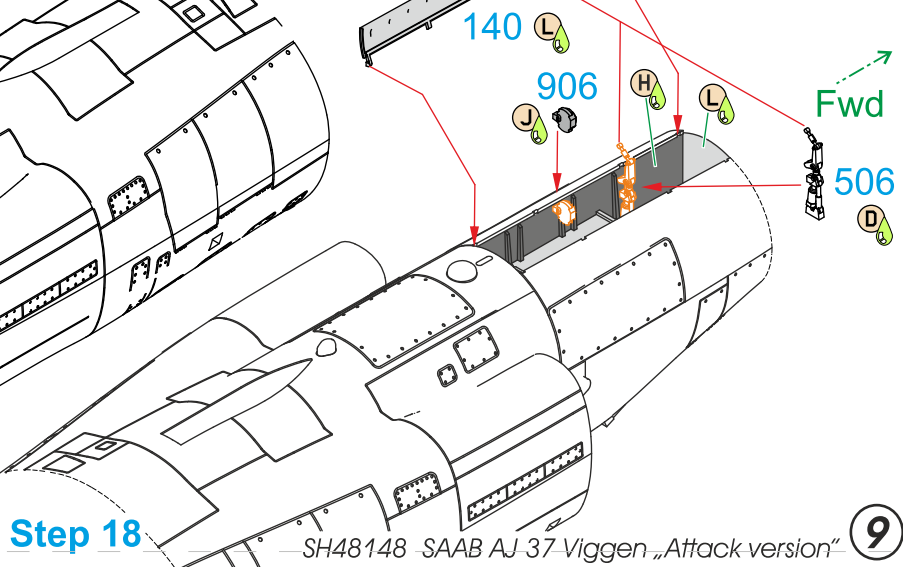

Step 18

20L

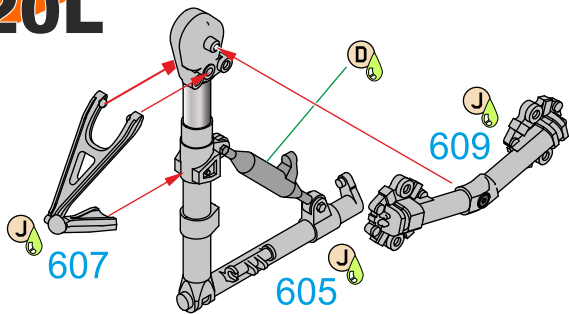

21L

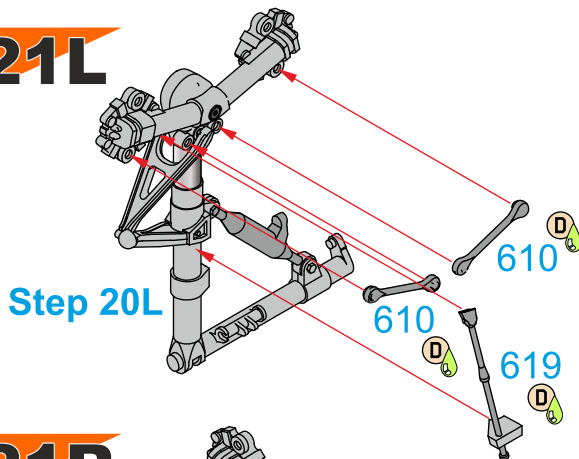

20R

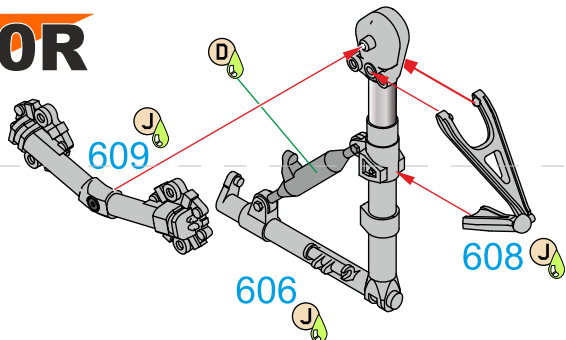

21R

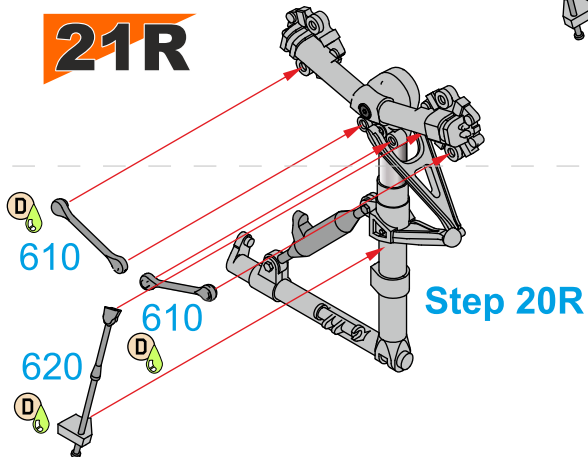

22L

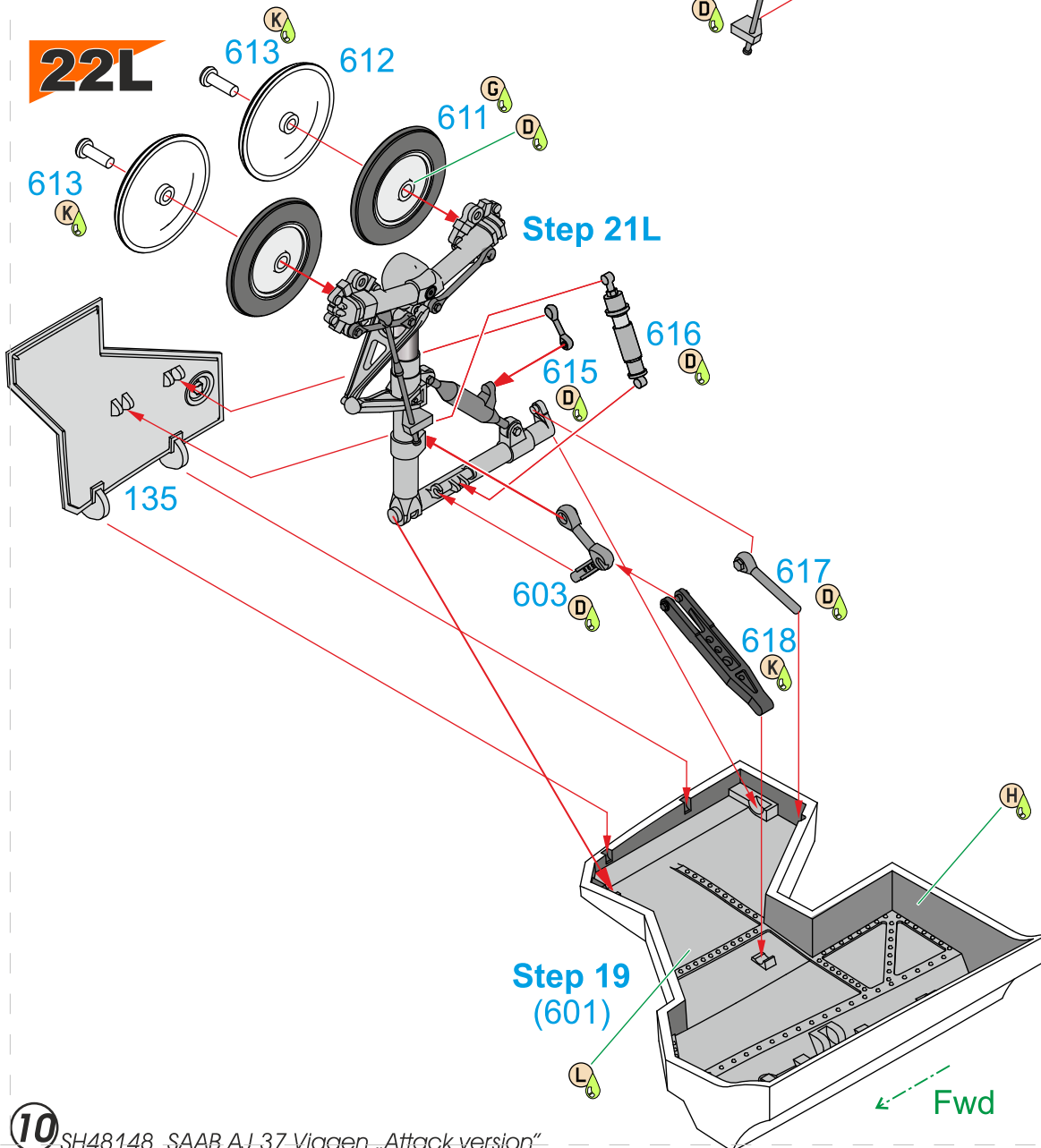

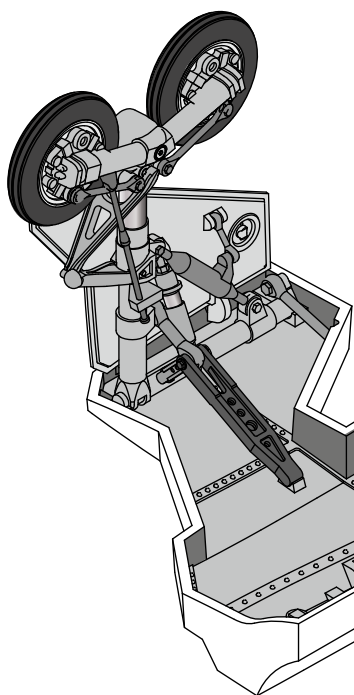
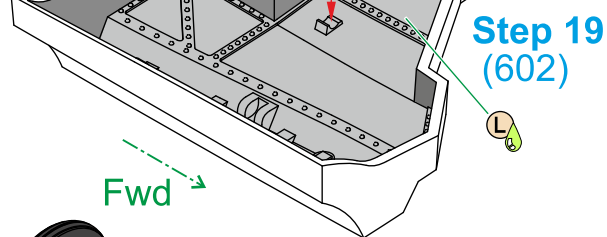
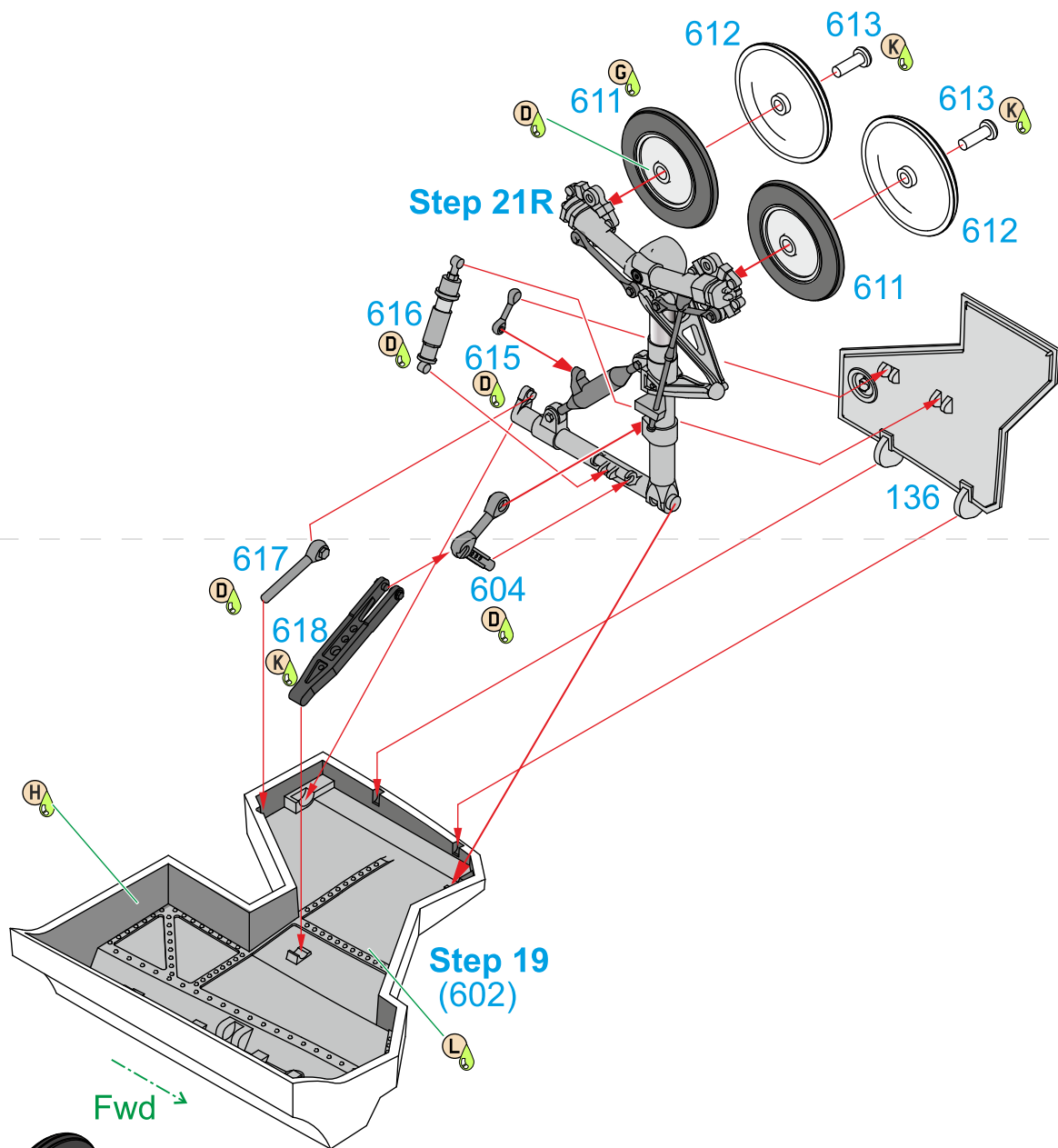

Info:
137 not drawn

INFO

Info:
138 in open position -
Inner doors were normally closed
when aircraft was parked/
vnitřní kryty jsou běžně zavřené,
když je letoun zaparkovaný

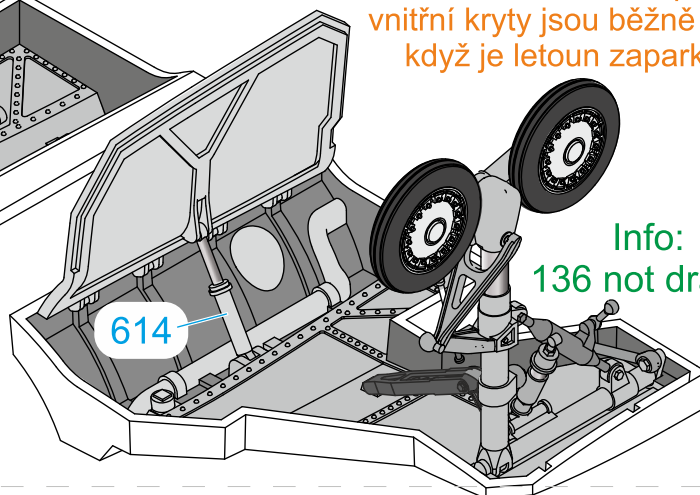

Info:
136 not drawn

23

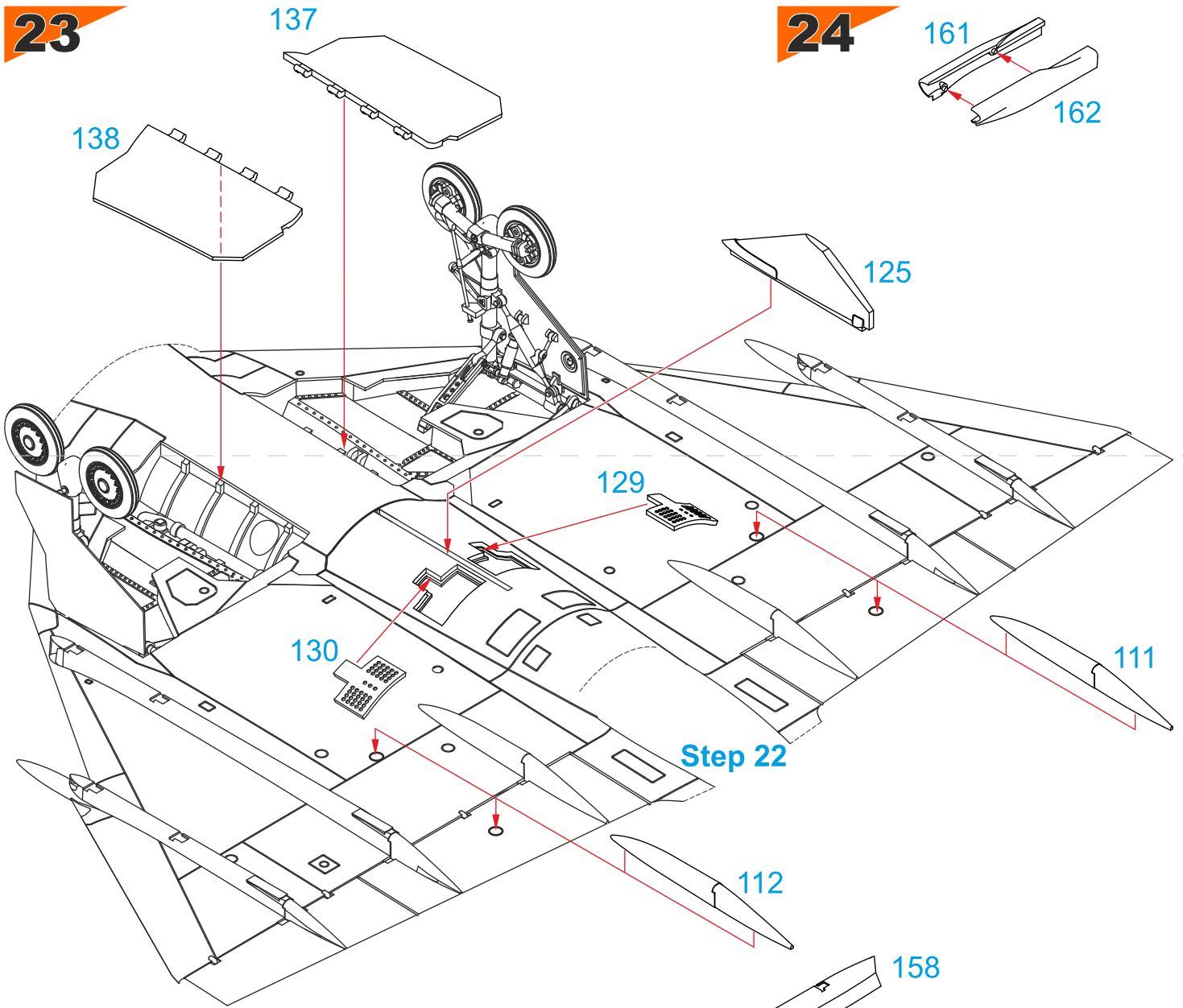

24

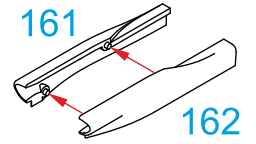

25

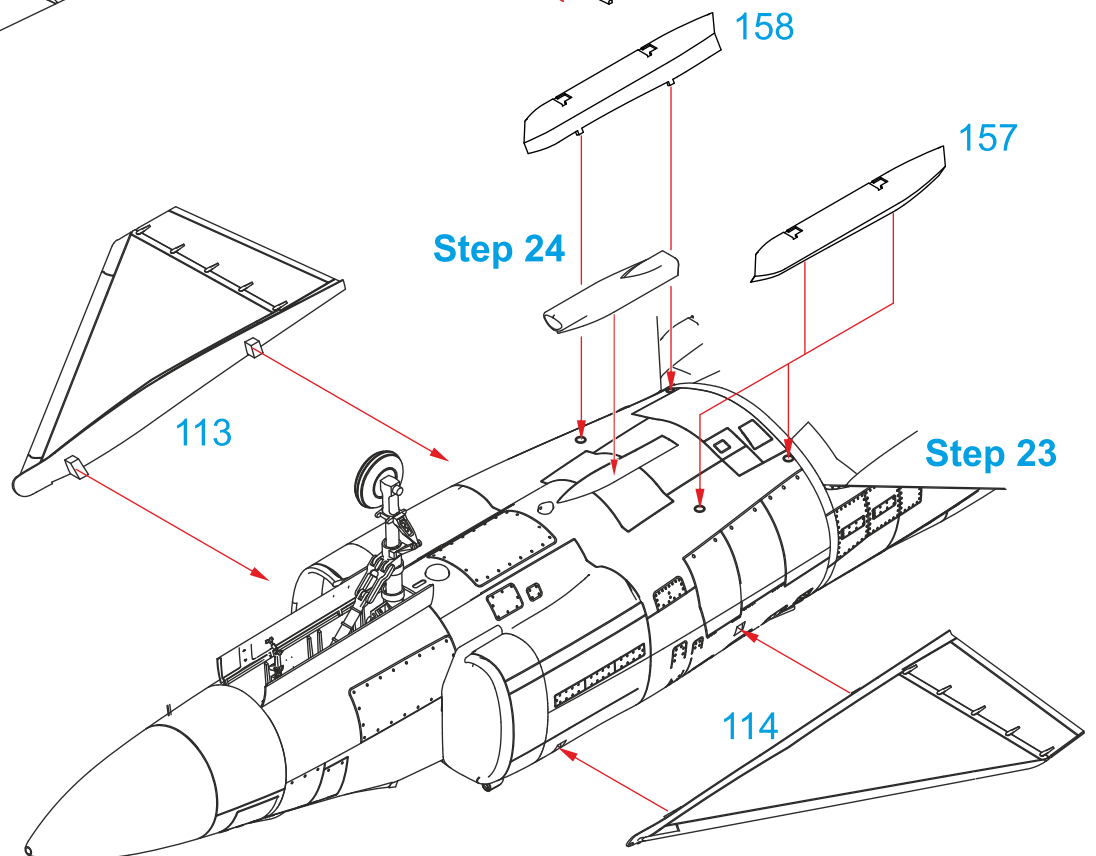

26 ?

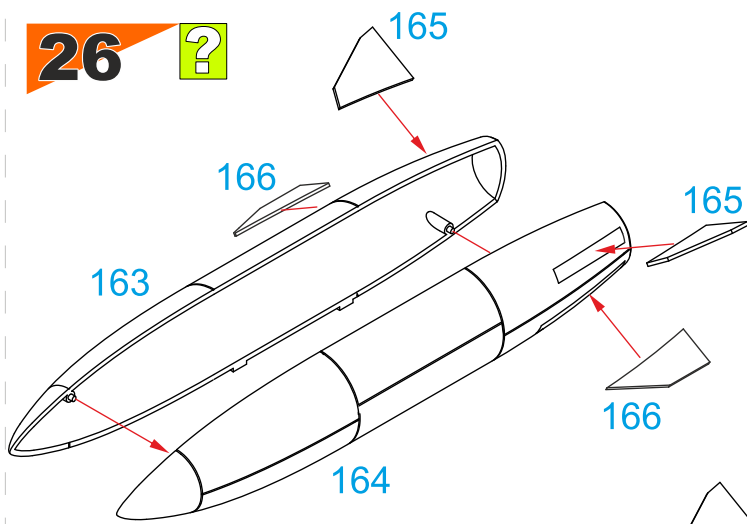

27 ?

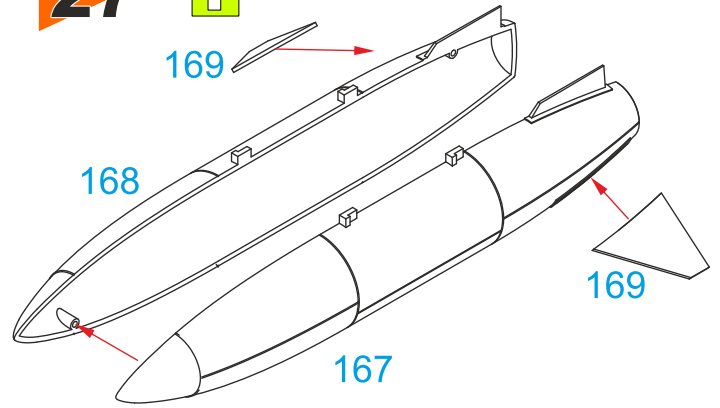

28

? Step 26

Step 27 ?

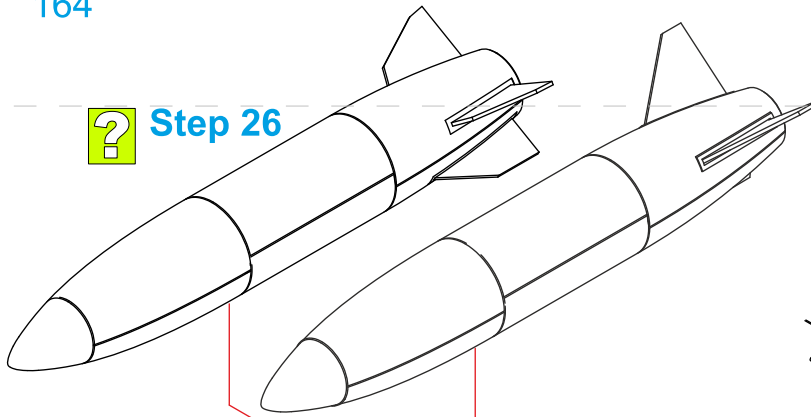

170

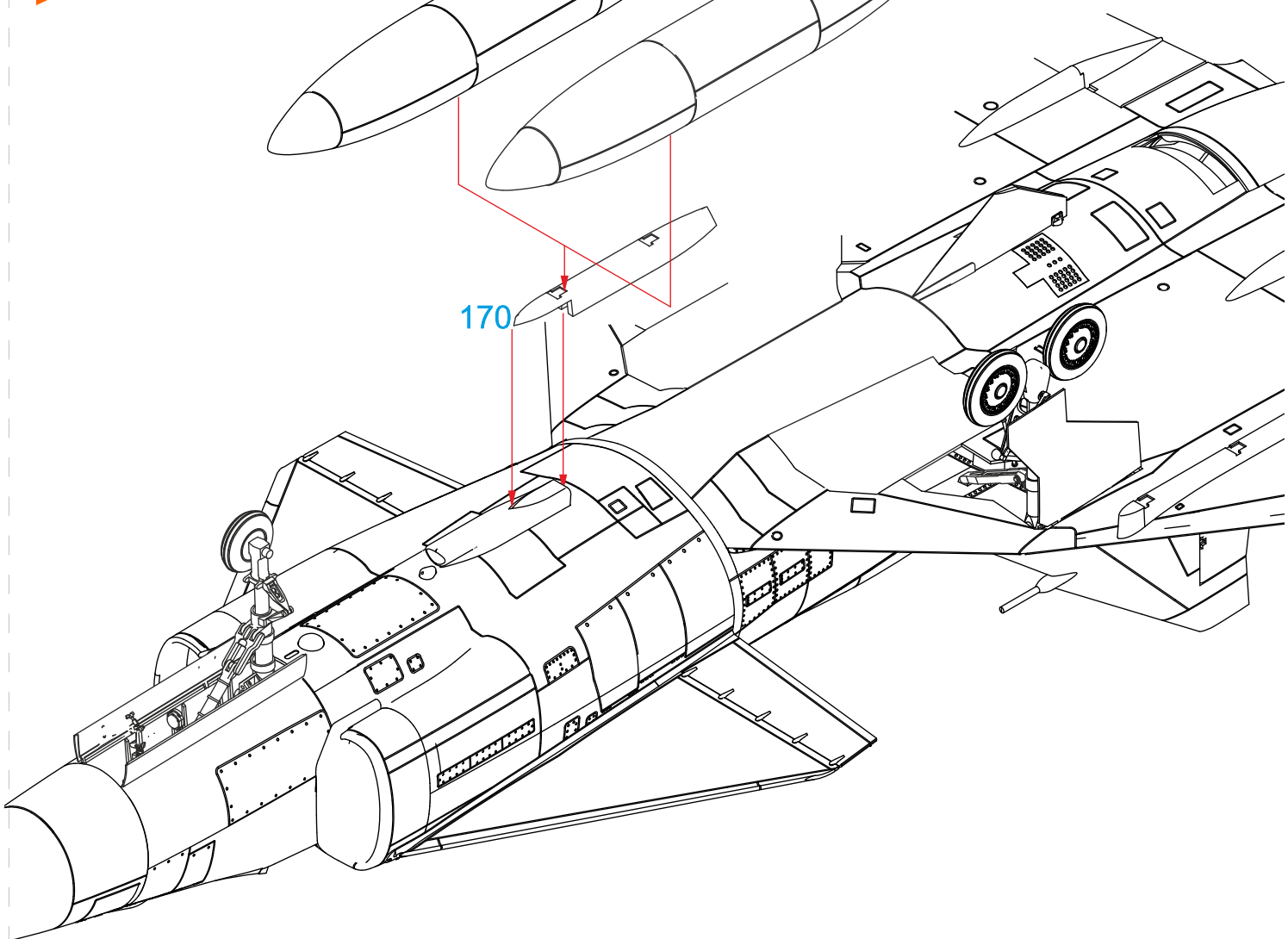

29

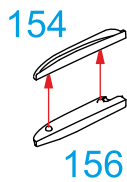

30

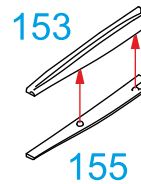

31

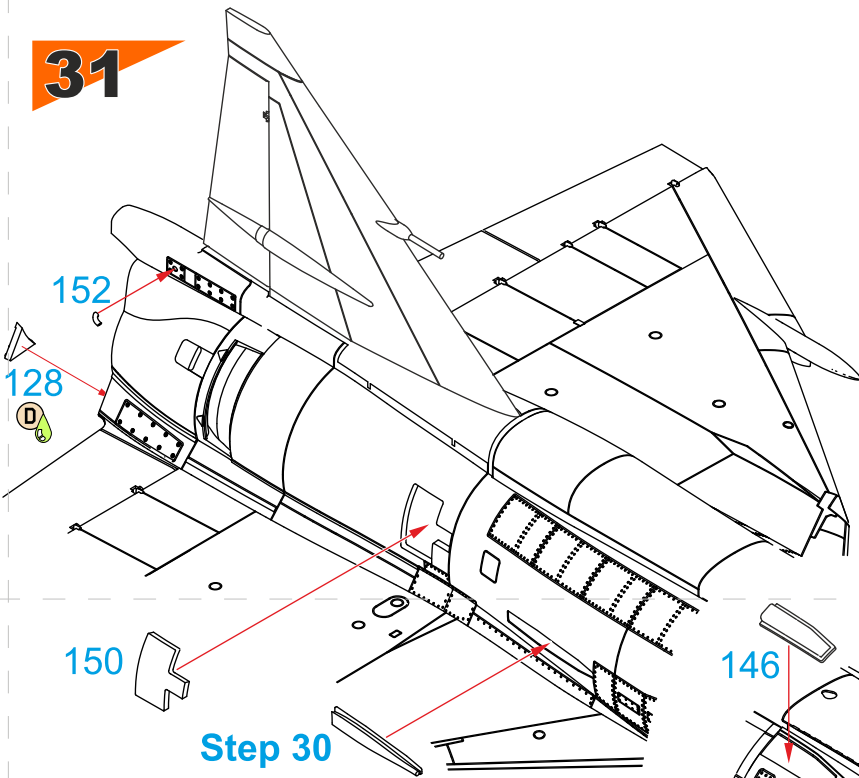

Step 30

32

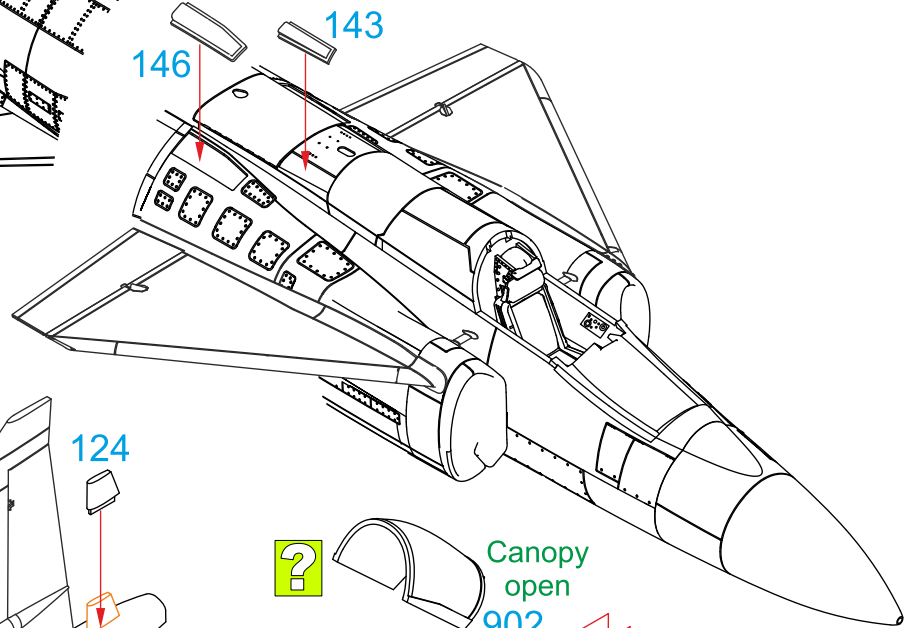

Canopy open
902

33

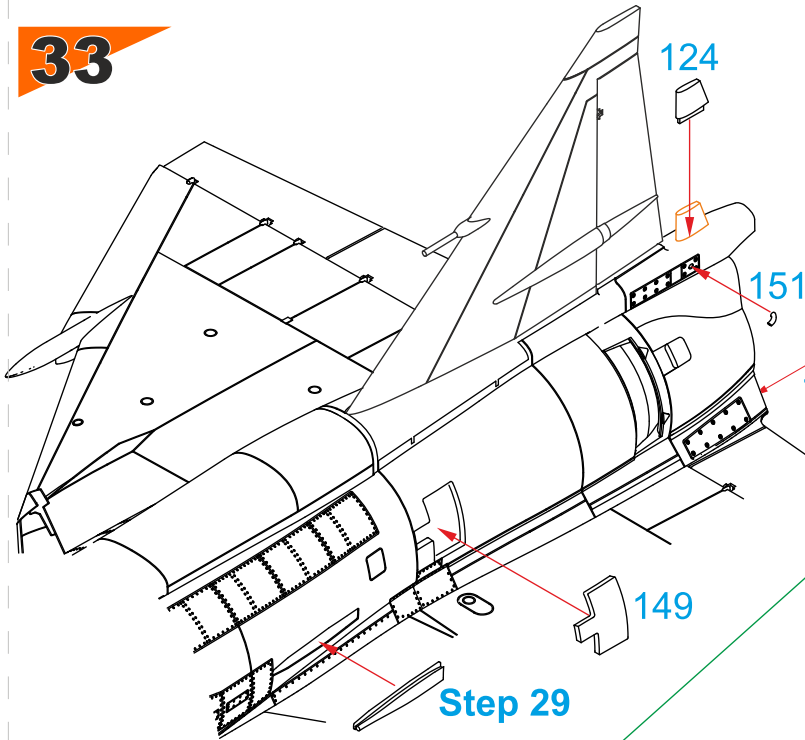

Step 29

34

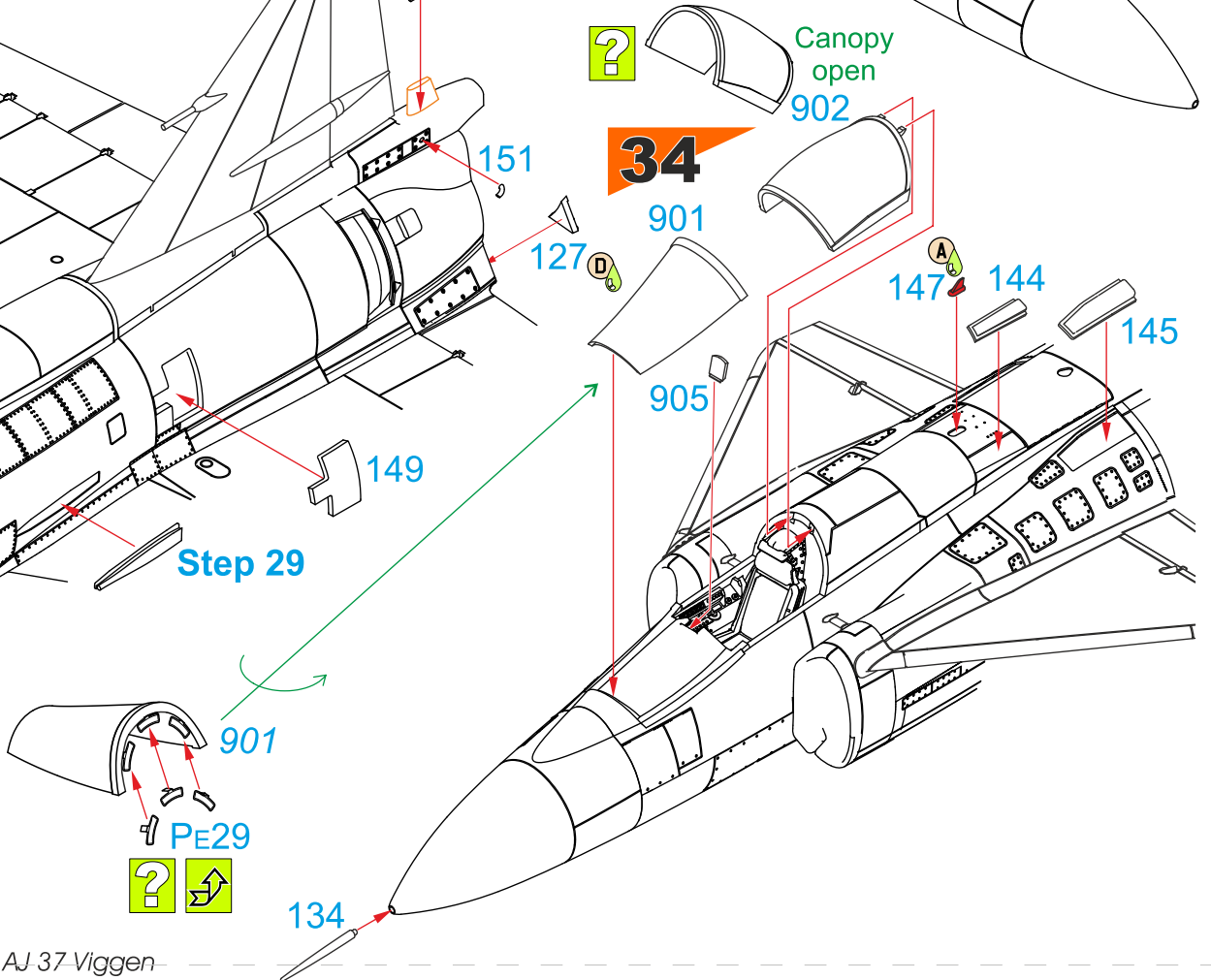

PE29

AJ 37 7-22

výr. čísla 37022 a volacího znaku Gustav 22, křídlo F7, Säténäs, 1973. V této podobě navštívil v září 1973 tento stroj Air show v tehdy západoněmeckém Buchelu.

CAM. B

AJ 37 7-22

s/n 37022, call sign Gustav 22, F7 wing, Säténäs, 1973. During the visit at Buchel in West Germany where an air show took place in September 1973, JBG 33 and JBG 36 squadron badges were put on the tail fin.

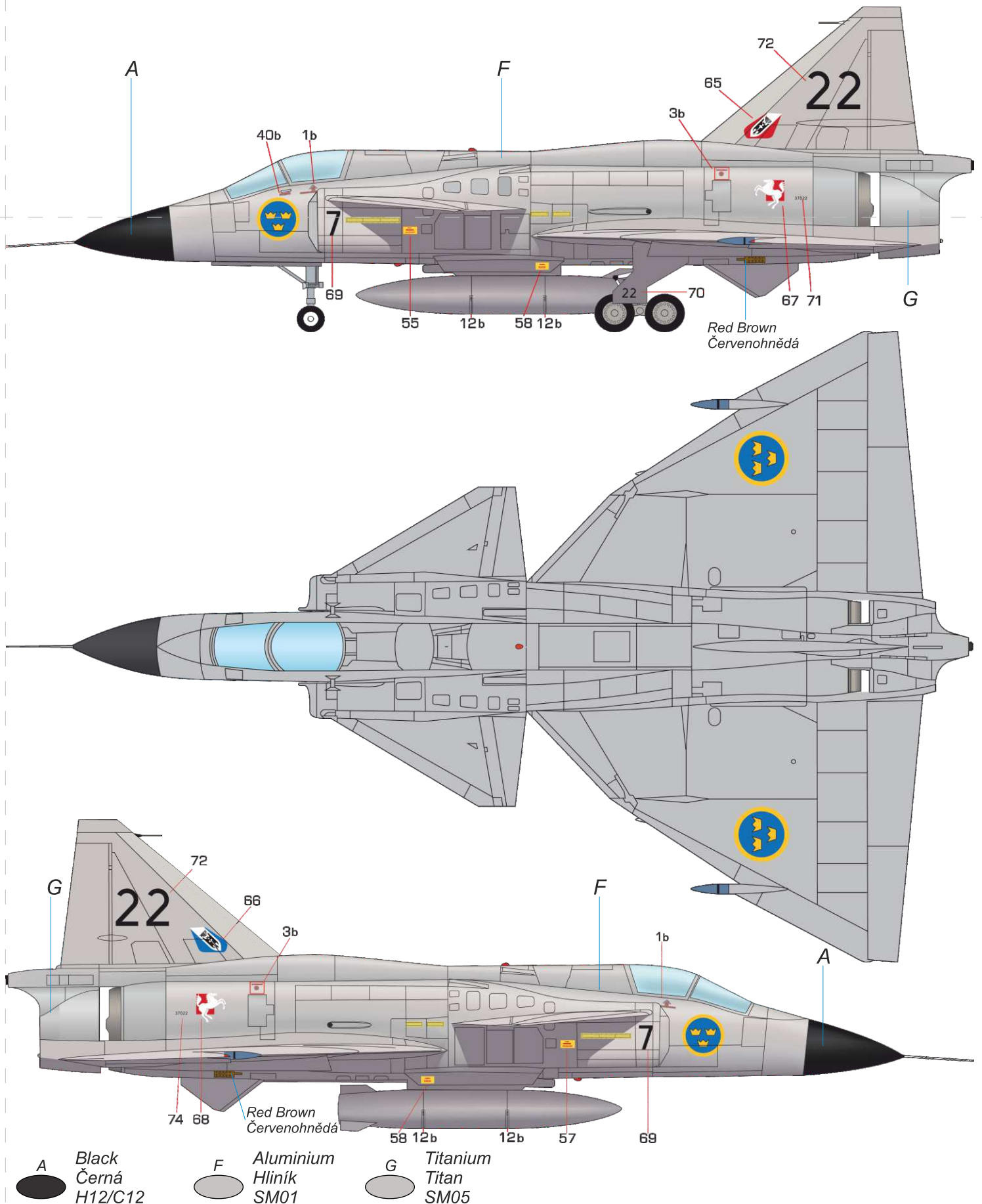

AJ 37 15-10

výr. čísla 37051, křídlo F15 Söderhamn, 1978. V této podobě, s jedním vstupem v barvě kovu se 15-10 zúčastnil Air show na základně F10 Ängelholm v červnu 1978.

CAM. C

AJ 37 15-10

s/n 37051, F15 wing, Söderhamn, 1978. With the starboard air intake replaced with an unpainted part, it was displayed at F10 Ängelholm during an air show in June 1978.

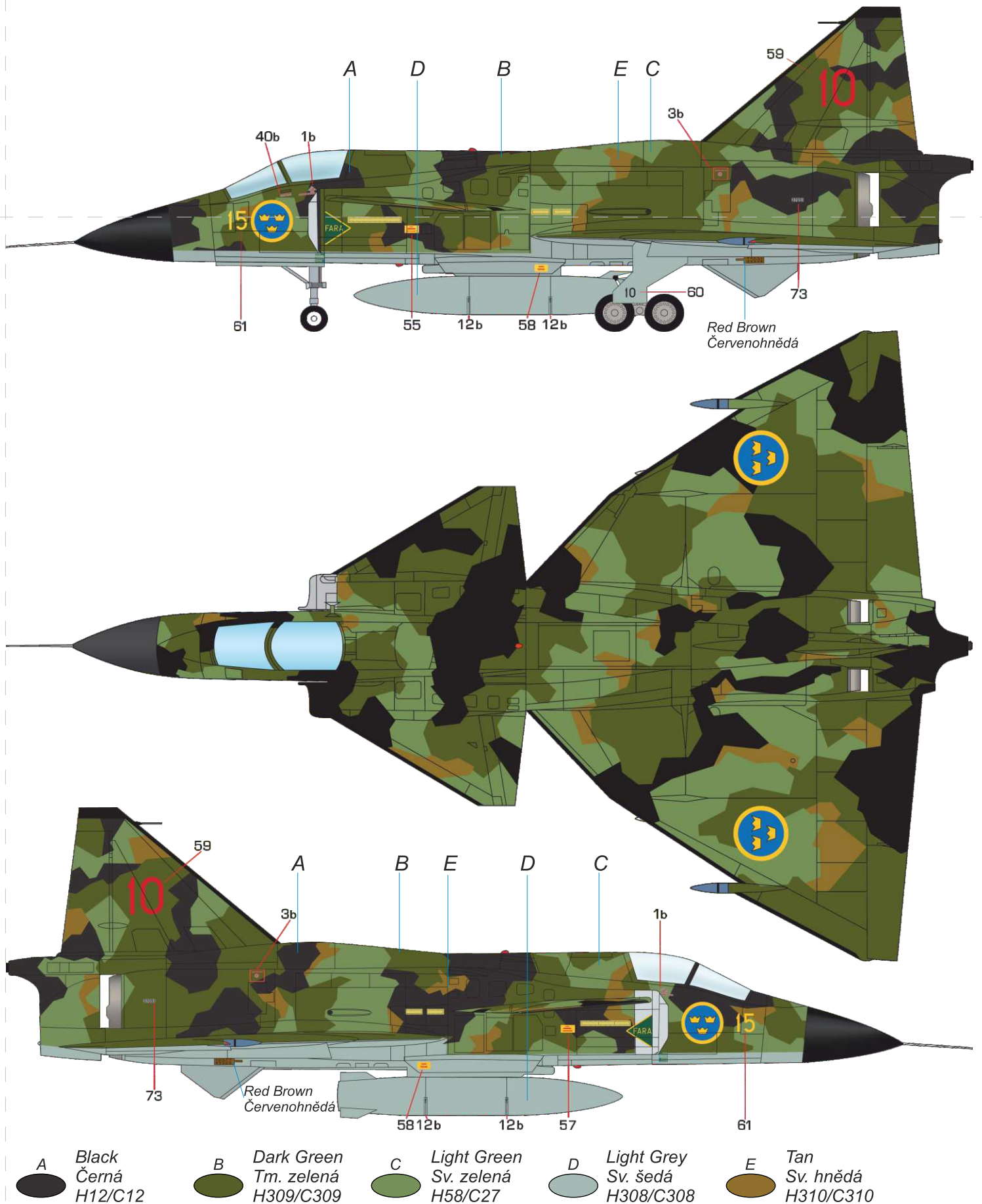

STENCILS

Detailed CMK and QUICK & EASY resin sets can be used for upgrading of all Viggen models.

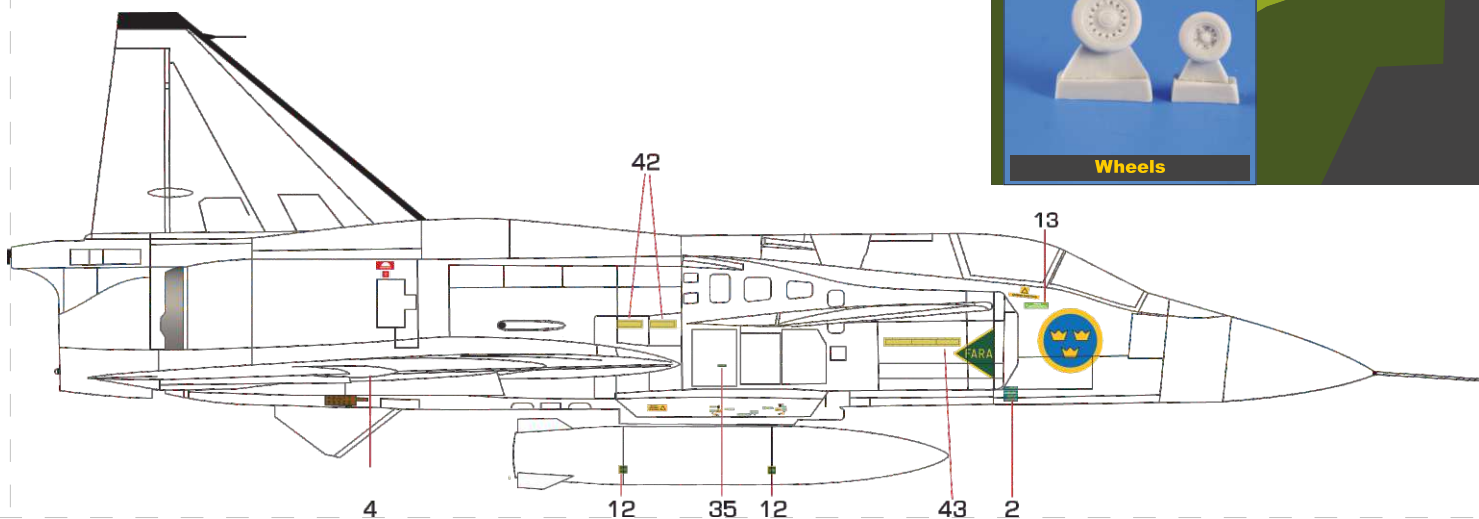
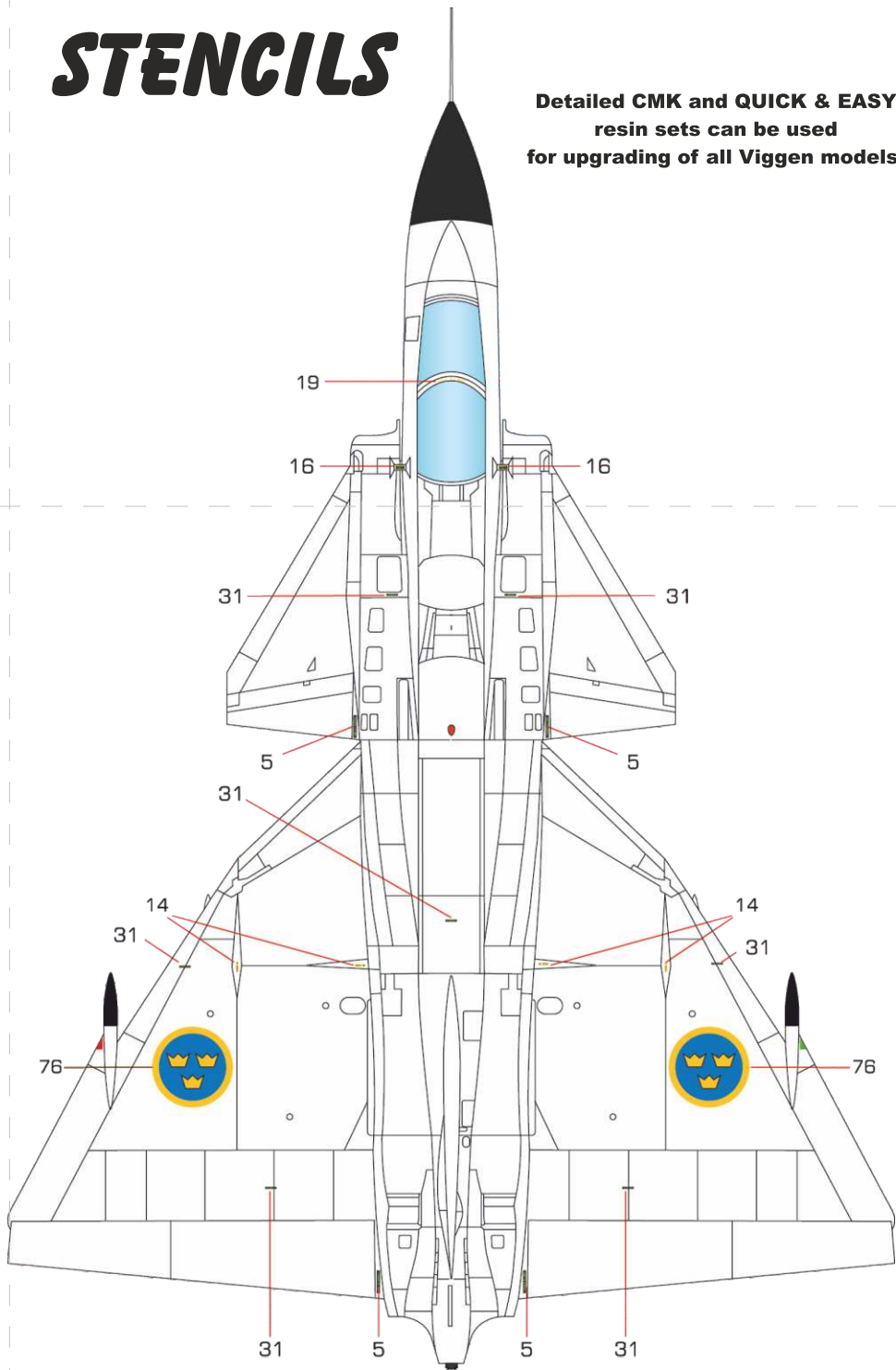

4310



m/70 Rocket pod (2 pcs)



Q48 219



Ejection Seat (Raketstol fpl 37)

Quick & Easy
Line
WITH QUALITY CAST PRODUCTS



Q48 222

Thrust Reverser



Q48 220



Air Brakes Set

Q48 221



Wheels

Inner wing pylon (V7H)

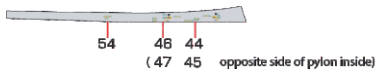

Fuselage pylon (S7H)

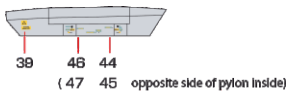

Outer Wing Pylon (R7H)
(no markings on AJ family)



Centre pylon (C7)

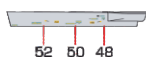

Fuselage pylon (S7V)

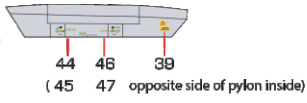

Inner wing pylon (V7V)

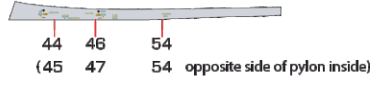

Centre pylon (C7)

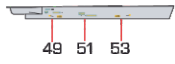

Outer Wing Pylon (R7V)
(no markings on AJ family)

