

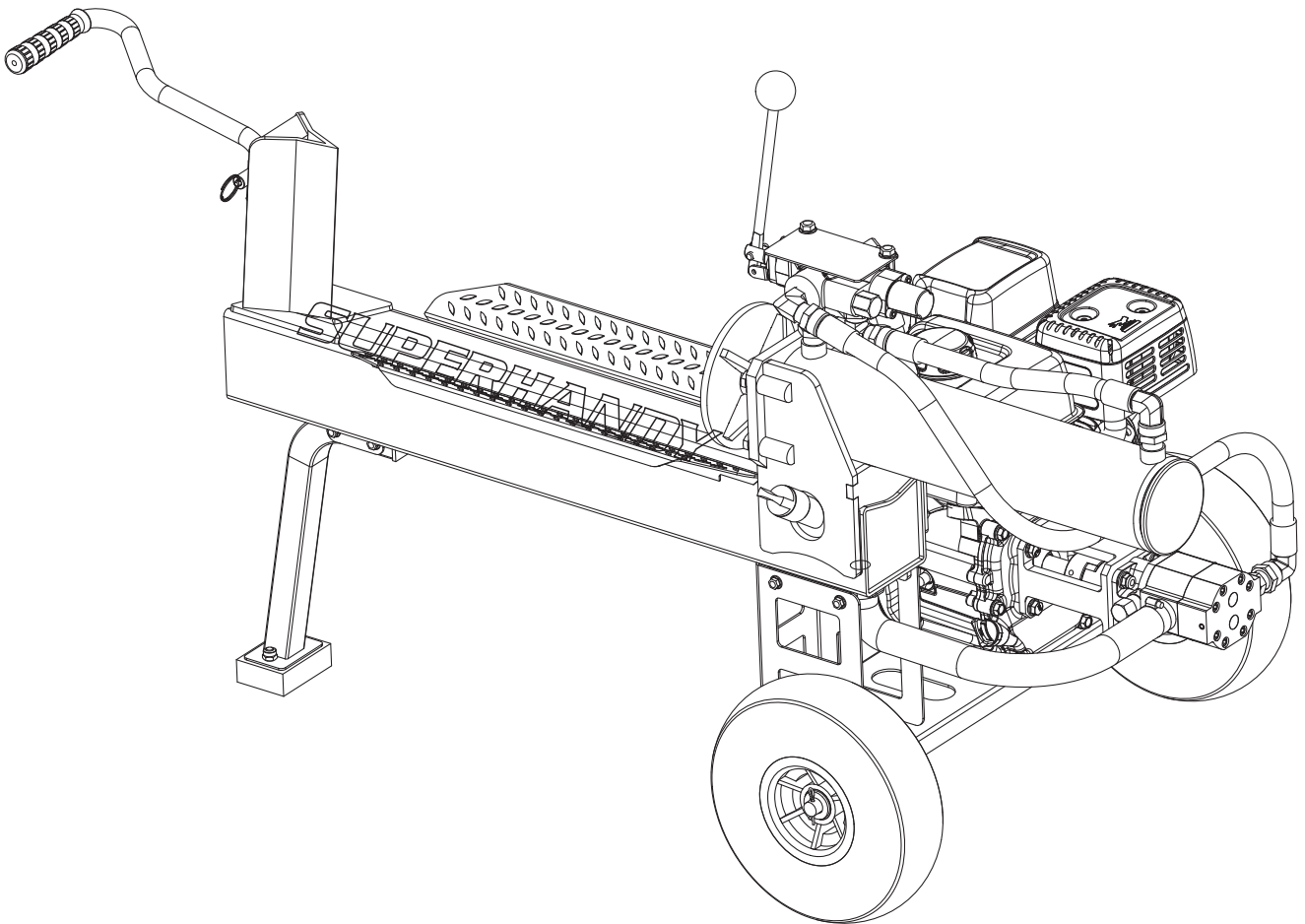

Gas Powered Hydraulic Log Splitter Operator's Manual



WARNING:

Read carefully and understand all **INSTRUCTIONS** before operating. Failure to follow the safety rules and other basic safety precautions may result in serious personal injury. Save these instructions in a safe place and on hand so that they can be read when required. Keep these instructions to assist in future servicing.

INDEX

TECHNICAL SPECIFICATIONS	1
SAFETY DEFINITIONS	2
SAFETY SYMBOLS	2~3
SAFETY GUIDELINES	4~5
FUEL SAFETY	5
CONTROLS AND FEATURES	6
PARTS LIST	6
ASSEMBLY	7~8
EXPANDED DRAWINGS	9
OPERATION	10~11
MAINTENANCE AND STORAGE	11
TROUBLE SHOOTING	11

TECHNICAL SPECIFICATIONS

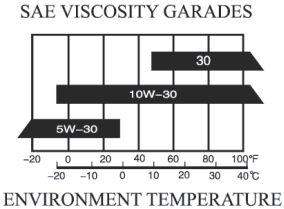





Maximum Exerted Splitting Force	20 (US tons)
Engine Specifications	7.0HP / 209CC
Starter Type	Recoil Start
Cycle Time	7.5 Seconds
Gear Pump	11GPM
Control Valve	Detent (auto-return)
Hydraulic Cylinder Stroke Length	16"
Max Log Length	20.5"
Max Log Width	16"
Hydraulic Fluid Type	AW32, AW46
Hydraulic Fluid Tank Capacity	2.1Gallon (8L)
Engine Oil Guide	<p>SAE 10W-30 is recommended for general use. Other viscosities shown in the chart may be used when the average temperature in your area is within the indicated range.</p>  <p style="text-align: right;">SAE VISCOSITY GRADES</p> <p style="text-align: center;">ENVIRONMENT TEMPERATURE</p>
Engine Oil Capacity	0.145Gallon (0.55L)
Fuel Type	87 octane gasoline with NO ethanol content NOTE: If using an ethanol blended fuel, a fuel stabilizer, mixed to manufacturer specifications recommended (See engine manual)
Fuel Tank Capacity	0.74Gallon (approx. 2.8L)
Wheel Diameter	10"
Net Weight	132LB
Overall Dimensions(L x W x H)	46.38" x 25.59" x 34.05" (Assembled)
Low Oil Shut-off	Yes
Emissions	EPA/CARB









SAFETY DEFINITIONS

The purpose of safety symbols is to attract your attention to possible dangers. The safety symbols, and their explanations, deserve your careful attention and review. The safety warnings do not by themselves eliminate any danger. The instructions or warnings they give are not substitutes for proper accident prevention measures and care while using the product.

SAFETY SYMBOLS

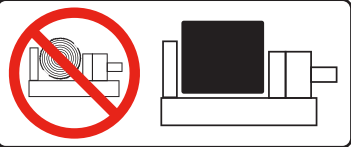
Some of the following symbols are used on this product. Please study them and learn their meanings. Proper interpretation of these symbols will help you to operate the product in a safe and responsible manner.

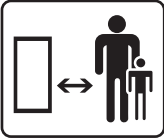
SYMBOL	MEANING
	<p>Read Operator’s Manual in its entirety. To reduce the risk of injury, user must read and understand operator’s manual before using this product.</p>
	<p>Eye and Ear Protection. Always wear safety goggles or safety glasses with side shields, and as necessary a full face-shield as well as full ear protection when operating this product.</p>
	<p>Footwear. Always wear safety shoes or work boots when operating the machine. Sandals and slippers or open toe shoes or any type are strongly discouraged.</p>
	<p>Gloves. Always wear nonslip, heavy-duty protective gloves when operating this product.</p>
	<p>Safety Alert. Precautions that involve your safety.</p>
	<p>Risk of Fire. Fuel and its vapors are extremely flammable and explosive. Fire can cause severe burns or death. Do not add fuel while the product is operating or still hot. Shut down the unit and wait for unit to cool before refilling the fuel, oil, or hydraulic fluid tanks.</p>
	<p>Skin Injection Hazard. Hydraulic oil under high pressure can penetrate your clothes skin. Make sure all fittings are fully seated and tightly secured before applying pressure. Relieve system pressure before servicing.</p>
	<p>Always keep hands away from the wedge and the ram. Moving parts can crush or cut.</p>

SYMBOL	MANING
	<p>Always keep feet away from the wedge and the ram. Moving parts can crush or cut.</p>
	<p>Hot Surface. To reduce the risk of injury or damage, avoid contact with any hot surface.</p>
	<p>Open Flame alert. Gas and its vapors are extremely flammable and explosive. Keep gas away from open flames, sparks, pilot lights, heat, and other potential ignition sources.</p>
	<p>Hold logs on sides when loading. Keep hands and feet away from cylinder, wedge, and partially split logs.</p>
	<p>Never place hands or any part of the body between a log and any part of the log splitter. Do not split logs against the grain. Split logs end to end in the direction of the grain only.</p>
	<p>Toxic Fumes. The engine exhaust from this product contains chemicals known to the state of California to cause cancer and birth defects and other reproductive harm. Risk of Asphyxiation. This engine emits carbon monoxide, an odorless, colorless poison gas. Breathing carbon monoxide can cause nausea, fainting or death. Use only in a well ventilated area. DO NOT use indoors (garage or shed or any enclosed area).</p>
	<p>Clearance. Keep all objects including others at least 10 feet (3m) from this machine. Only one person should operate the log splitter and load the logs.</p>
	<p>Never operate on an incline. Make sure the splitter is on a level surface. Block tires and ensure support leg is secure to prevent unintended movement of the log splitter during operation.</p>

⚠ DANGER

DANGER indicates a hazardous situation which, if not avoided, will result in serious injury and possibly death.

⚠ WARNING

WARNING indicates a potential hazardous situation which, if not avoided, could result in serious injury or death.

⚠ CAUTION

CAUTION indicates a hazardous situation which, if not avoided, could result in minor or moderate injury.

⚠ NOTE

NOTICE indicates information considered important, but not hazard-related (e.g., messages relating to property damaged).

SAFETY GUIDELINES

⚠ WARNING

Cancer and Reproductive Harm – www.P65Warnings.ca.gov

⚠ DANGER

Log splitter engine exhaust contains carbon monoxide, a colorless, odorless, poison gas. Breathing carbon monoxide will cause nausea, dizziness, fainting or death.

If you start to feel dizzy or weak, get to fresh air immediately.

⚠ DANGER

Using an engine indoors **CAN KILL YOU IN MINUTES**. Engine exhaust contains carbon monoxide. This is a poison you cannot see or smell.

NEVER use inside a home or garage, **EVEN IF** doors and windows are open.

ONLY use **OUTSIDE** and far away from windows, doors, and vents.

Install battery-operated carbon monoxide alarms or plug-in carbon monoxide alarms with battery back-up according to the manufacturer's instructions to protect your home and loved ones from possible harm.

⚠ DANGER

Moving parts can entangle hands, feet, hair, clothing and/or accessories. Traumatic amputation or severe laceration can result. Keep hands and feet clear moving parts. Tie up long hair and remove jewelry before operating the device. Operate equipment only fully assembled and with guards in place.

DO NOT wear loose-fitting clothing, dangling drawstrings or items that could become caught.

⚠ WARNING

Operation of this equipment may create sparks that can start fires around dry vegetation.

Spark arrestor may be required. The operator should contact local fire agencies for laws or regulations relating to fire prevention requirements.

⚠ WARNING

Running engines produce heat. Severe burns can occur on contact. Combustible material can catch fire on contact.

DO NOT touch hot surfaces.

Avoid contact with hot exhaust gases.

Allow equipment to cool before touching.

Maintain at least 3 ft. (91.4 cm) of clearance on all sides to ensure adequate cooling.

Maintain at least 5 ft. (1.5 m) of clearance from combustible materials.

⚠ WARNING

Crush Hazard

Wedge can cut through skin and break bones and in extreme cases amputate limbs and digits. Keep all limbs away from wedge and endplate at all times.

⚠ WARNING

Skin Injection Hazard. High pressure hydraulic oil can break skin and cause sever injury.

Make sure all fittings are seated firmly and tightly secured before applying pressure. Relieve system of pressure before servicing.

⚠️ WARNING

Rapid retraction of the starter cord will pull hand and arm towards the engine faster than you can let go. Unintentional startup can result in entanglement, traumatic amputation or laceration. Broken bones, fractures, bruises or sprains could result. When starting engine, pull the starter cord slowly until resistance is felt and then pull rapidly to avoid kickback.

⚠️ CAUTION

Parts of the hydraulic circuit (cylinder, pump, valve-body, hoses) can become very hot during operation.

⚠️ WARNING

This product IS **NOT** intended to be towed behind a vehicle of any sort. The handle and wheels of the product are intended for the sole purpose of easily moving the log splitter on your work site. Any modification or changes to allow moving of this product by any other means other than by hand will render all warranties null and void.

⚠️ CAUTION

Improper treatment or use of the log splitter can damage it, shorten its life and void your warranty.

Use the log splitter only for intended uses.

Operate only on level surfaces.

DO NOT expose log splitter to excessive moisture, dust, or dirt. Cover with a tarp or store in a shed when not in use.

DO NOT allow any material to block the cooling vents.

DO NOT use product if you observe engine if:

- Equipment sparks, smokes or flames from the motor
- Equipment vibrates excessively.
- Hydraulic Fluid is leaking from the unit

GAS SAFETY

⚠️ DANGER

GASOLINE AND GASOLINE VAPORS ARE HIGHLY FLAMMABLE AND EXPLOSIVE.

Fire or explosion can cause severe burns or death.

When adding or removing gasoline:

Turn the engine off and let it cool for at least two minutes before removing the gasoline cap. Loosen the cap slowly to relieve pressure in the tank.

Only fill or drain gasoline outdoors in a well-ventilated area.

DO NOT pump gasoline directly into the engine at the gas station.

Use an approved container to transfer the gas to the engine.

DO NOT overfill the gasoline tank.

Always keep gasoline away from sparks, open flames, pilot lights, heat and other sources of ignition.

DO NOT light or smoke cigarettes while fueling.

When starting the engine:

DO NOT attempt to start a damaged engine.

Make certain that the gasoline cap, air filter, spark plug, gas lines and exhaust system are properly in place.

Allow spilled gasoline to evaporate fully before attempting to start the engine.

Make certain that the log splitter is resting firmly on level ground.

When operating the log splitter:

DO NOT move or tip the log splitter during operation.

DO NOT tip the log splitter or allow fuel or oil to spill.

When transporting or servicing the log splitter:

Make certain that the gas valve is in the OFF position, the gasoline tank is empty.

Disconnect the spark plug wire.

When storing the log splitter:

Store away from sparks, open flames, pilot lights, heat and other sources of ignition.

Do not store log splitter or gasoline near furnaces, water heaters, or any other appliances that produce heat or have automatic ignitions.

⚠️ WARNING

NEVER use a gasoline container, gasoline tank, or any other gas item that is broken, cut, torn or damaged.

CONTROLS AND FEATURES

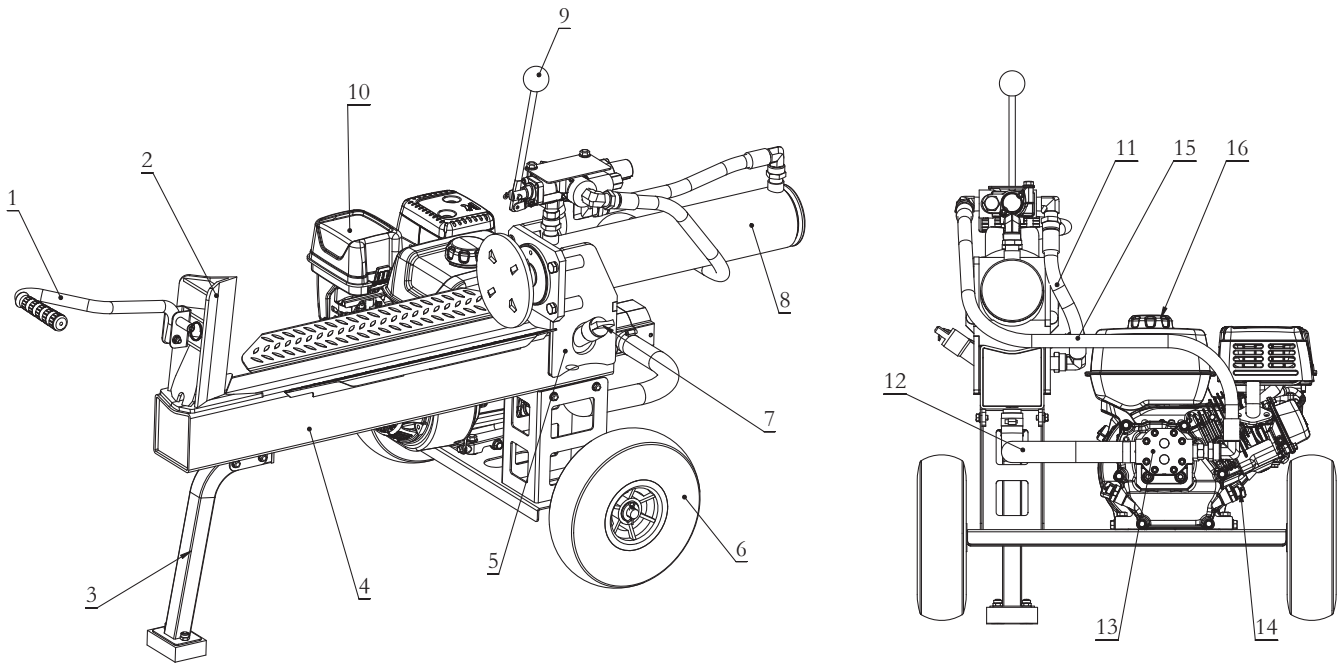

1. Handle
2. Splitting Wedge
3. Support Leg – Supports log splitter while operating.
4. Splitting Support Beam---**DO NOT PUNCTURE** The hydraulic tank is inside.
5. Hydraulic cylinder base.
6. 10" Wheels
7. Hydraulic Oil Dipstick – Add or check Hydraulic oil level.
8. Hydraulic Cylinder – Converts hydraulic pressure into linear force.
9. Control Valve Handle – Controls the movement of the thrust plate.
10. Engine 209cc 4-stroke, air cooled.
11. Hydraulic Oil Return (Low Pressure) Hose – returns hydraulic oil back into the hydraulic tank.
12. Suction Hose – Draws hydraulic oil from the tank into the pump.
13. Hydraulic Pump – Pumps hydraulic oil through the system.
14. Engine Oil Fill Cap / Dipstick – Add or check the motor oil level.
15. Hydraulic Oil Inlet (High Pressure) Hose – Feeds hydraulic oil into the hydraulic cylinder.
16. Fuel tank cap.

PARTS LIST

Engine	Primary Beam Kit	Bottom Plate	Supporting Bar	Wheels	Control Valve Handle
Hydraulic Cylinder	Handle	Oil Hose	Outer hexagon bolt M10x 30mm	Hexagon Flange Bolt M8x35mm	Hexagon Flange Bolt M6x45mm
Hose Clamp	Flat Washer	R pin	Spring Washer	M8 Nut	M6 Nut
			Oil Dipstick		Hexagon Flange Bolt M6x35mm

ASSEMBLY

Recommended tools



STEP #1

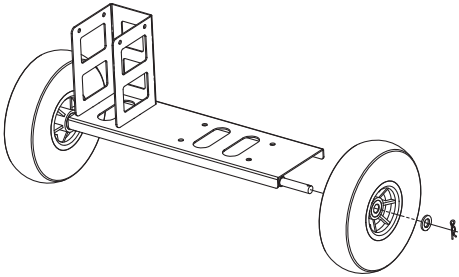

Recommended tools: Needle nose pliers

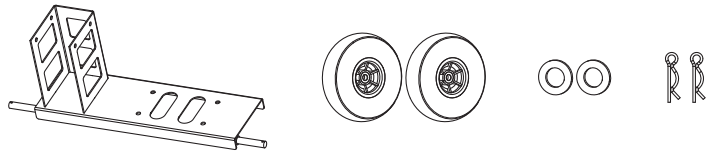

STEP #2

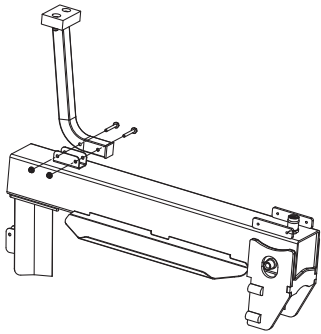

Recommended tools: Ratchet Wrench (10mm)

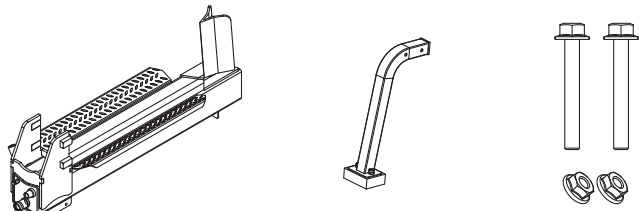

M6 Nut,
Hexagon Flange Bolt M6x45mm

STEP #3

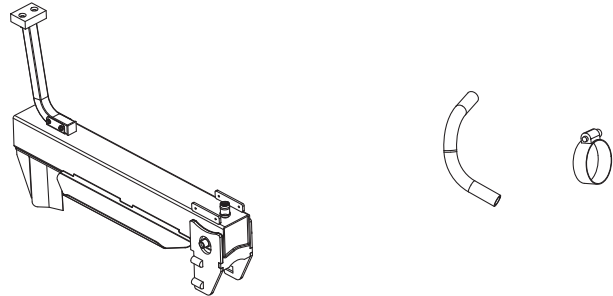
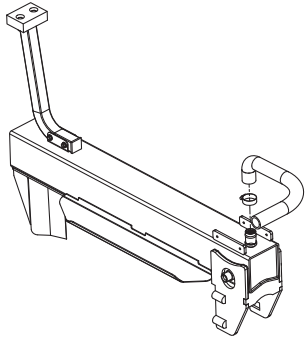



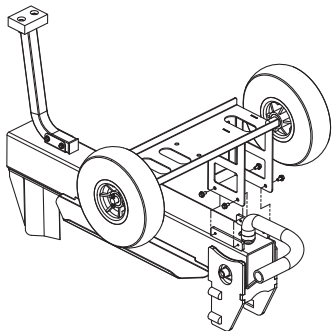

STEP #4

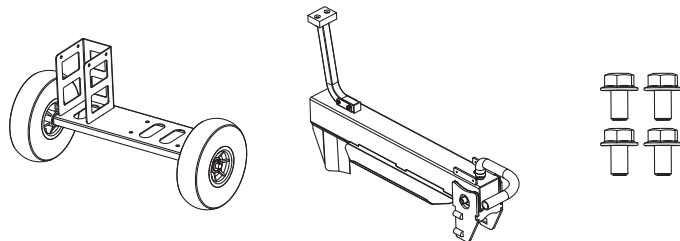

Recommended tools: Ratchet Wrench (10mm)

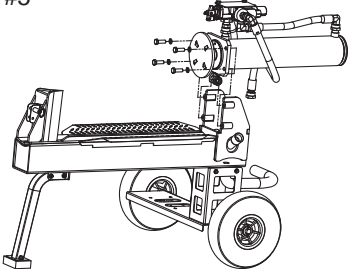
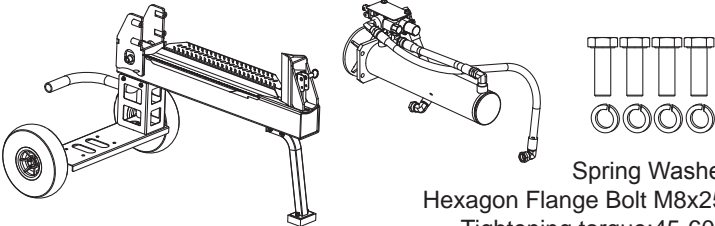
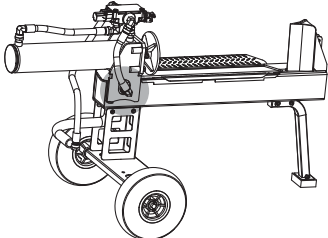
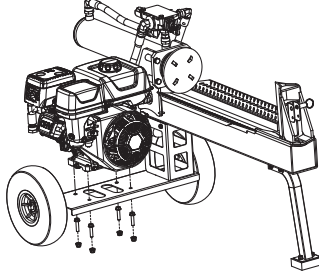

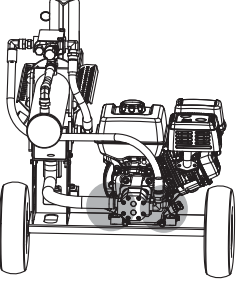
Hexagon Flange Bolt M6x12mm Tightening torque:9-12 N.m

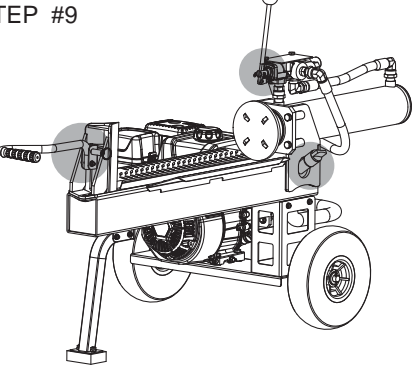
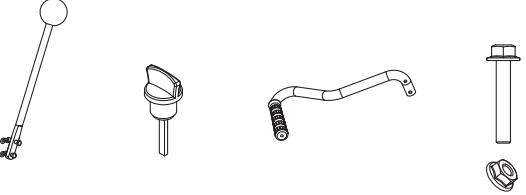
<p>STEP #5</p> 	<p>Recommended tools: Wrench (16mm)</p>  <p>Spring Washer φ8 Hexagon Flange Bolt M8x25mm Tightening torque:45-60 N.m</p>
<p>STEP #6</p> 	<p>Recommended tools: Wrench (27mm 22mm)</p> <p>Hose connector recommend tightening torque:80 N.m</p>
<p>STEP #7</p> 	<p>Recommended tools: Wrench (13mm)</p>  <p>M8 Nut, Hexagon Flange Bolt M8x35mm Tightening torque:25-30 N.m</p>
<p>STEP #8</p> 	<p>Recommended tools: Wrench (27mm 22mm)</p>  <p>Hose connector recommend tightening torque:80 N.m</p>
<p>STEP #9</p> 	<p>Recommended tools: Wrench (10mm)</p>  <p>M6 Nut, Hexagon Flange Bolt M6x35mm,</p>
<p>STEP #10</p>	<p>Add gas, oil and hydraulic fluid before first Use.</p>

EXPLODED DRAWINGS

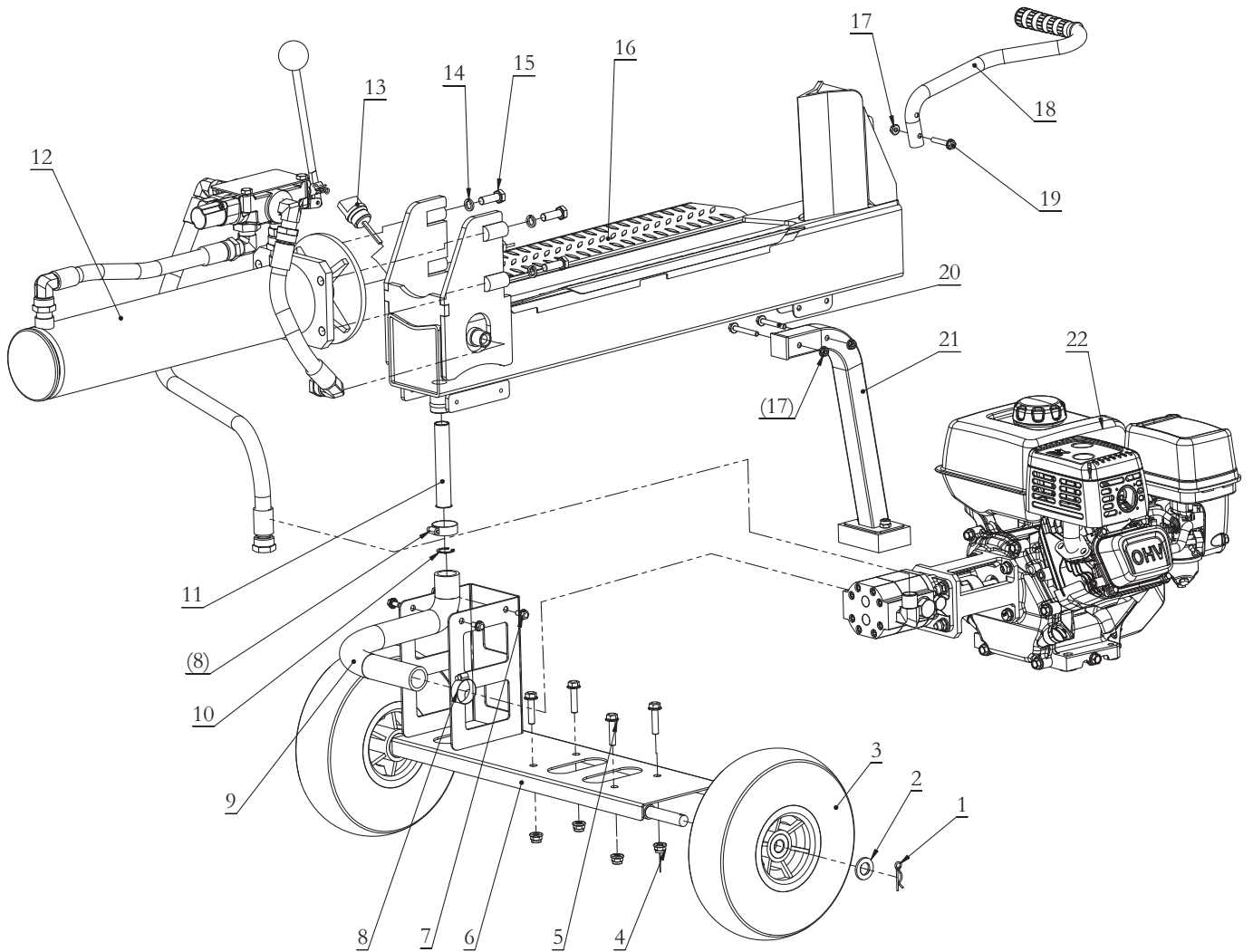

Part No.	Description	Q'ty	Part No.	Description	Q'ty
1	R Pin	2	12	Hydraulic Cylinder Kit	1
2	Flat Washer	2	13	Oil Dipstick	1
3	10 " Wheel	2	14	Spring Washer	4
4	Flange Nut M8	4	15	Outer hexagon bolt M10x 30mm	4
5	Hexagon Flange Bolt M8x40mm	4	16	Primary Beam Kit	1
6	Bottom Plate	1	17	Flange Nut M6	3
7	Hexagon Flange Bolt M8x20mm	4	18	Handle	1
8	Hose Clamp	2	19	Hexagon Flange Bolt M6x35mm	1
9	Oil Hose	1	20	Hexagon Flange Bolt M6x45mm	2
10	Elastic Ring	1	21	Supporting Bar	1
11	Filter	1	22	Engine	1

OPERATION

1. Read the Operator's Manual completely before attempting to use this log splitter.
2. Do not allow anyone to operate your log splitter who has not read the Operator's Manual or has not been instructed on the safe use of the log splitter.
3. Never allow children or untrained adults to operate this machine.
4. Never leave the machine unattended with the engine running.
5. Never operate the machine when under the influence of alcohol, drugs or medication
6. Many accidents occur when more than one (1) person operates the log splitter. If a helper is assisting in loading logs to be split, never actuate controls until helper is clear of the area.
7. Never allow anyone to ride on the machine during use or during operation.
8. Never transport cargo on the log splitter.
9. Always operate the log splitter with all safety equipment in place and all controls properly adjusted for safe operation.
10. High fluid pressures are contained in hydraulic log splitters.
Pressurized hydraulic fluid escaping through a pin hole opening can puncture skin and cause severe bleeding and result in blood poisoning. Therefore, the following instructions should be heeded at all times.
 - Be sure to confirm all hose connections and hose clamps are tight before each use. It is possible for connections to vibrate loose over time
 - Do not operate the unit with frayed, kinked, cracked or damaged hoses, fittings, or tubing.
 - Stop the engine and relieve hydraulic system pressure before changing or adjusting fittings, hoses, tubing, or other system components.
 - Do not adjust the pressure settings of the pump or valve. The factory presets are tested for optimal system performance. Tampering with or modifying these settings will render your product warranty null, and void.
 - Do not check for leaks with your hand. Leaks can be detected by passing cardboard or wood over the suspected area. Look for discoloration. If injured by escaping fluid, see a doctor at once. Serious infection or allergic reaction can develop if proper medical treatment is not administered immediately.
11. Keep the operation zone and adjacent area clear for safe, secure footing.
12. Always keep hands and feet clear of moving parts.
13. If your log splitter is equipped with an internal-combustion engine and intended for use near any unimproved forest, brush, or grass covered land, the engine exhaust should be equipped with a spark arrestor. Make sure you comply with local, state, and federal codes. Take appropriate fire-fighting equipment with you.
14. Log splitters should be used only for splitting wood. Do not use for other purposes unless the manufacturer provides attachments and instructions for such purposes.
15. When loading a ram-type log splitter, place your hands on the sides of the log, not the ends. Never place your hands or any part of your body between a log and any part of the log splitter
16. Only split wood WITH the grain. **NEVER** split perpendicular to the grain.
17. On ram-type log splitters, never attempt to split more than one log at a time unless the ram has been fully retracted and a second log is needed to complete the splitting of the first log.
18. On ram-type log splitters when the logs are not squared, the longest portion of the log should be rotated down and the most squared end placed against the ram.
19. Use only your hand to operate the log splitter controls, never kick the handle with your feet.
20. Do not refuel the engine until it has cooled for several minutes.

CAUTION

* Please read Alphaworks "Gasoline Engine Manual" for engine operation requirements and precautions.

WARNING

Add Hydraulic Oil

DO NOT remove the hydraulic oil fill cap when the engine is running or hot. Hot oil can escape causing severe burns.

Always allow the log splitter to cool completely before removing the hydraulic oil cap.

High fluid pressure and temperatures are created in the hydraulic log splitters. Hydraulic fluid will escape through a pin-size hole opening and can puncture skin.

Inspect hydraulic system regularly for possible leaks.

Never check for leaks with your hand while the system is pressurized.

Seek medical attention immediately if injured by escaping fluid.

NOTE

To check hydraulic oil level, insert the dipstick into fill neck until it stops.

Remove and read level. Do not thread dipstick into fill neck when checking oil.

When the outdoor temperature is below 32°F, Dexron III transmission fluid can be used.

1. Make sure the log splitter is on a flat, level surface.
2. Remove the dipstick from the oil tank.
3. Add 1.6gallon of hydraulic oil - AW32 / AW46
4. Check hydraulic oil level with oil dipstick. The oil level should be on the dipstick.
5. Tighten the dipstick.
6. Start engine (see Starting the Engine in the Operation section).
7. Extend and retract the cylinder to purge air from the hydraulic system. Cylinder motion should be smooth and continuous.

8. Shut-off engine (see Stopping the Engine in the Operation section).
9. Hydraulic oil can be added appropriately when the cylinder thrust is insufficient.

⚠ WARNING

For safety reasons, hydraulic oil, oil and fuel are not included in the package.

MAINTENANCE AND STORAGE

1. Always shut off the power source while repairing or adjusting the splitter except as recommended by the manufacturer.
2. Clean debris from the engine cylinder, cylinder head fins, recoil starter cover, and muffler areas. If the engine is equipped with a spark arrestor muffler, clean and inspect it regularly (follow manufacturer's service instructions). Replace, if damaged.
3. Never store the unit indoors with fuel in the tank. Fumes might reach an open flame spark. Allow the engine to cool before storing in any enclosure.
4. Clear debris from movable parts, but only when the power source is shut off.
5. Check to be sure all nuts and bolts are tight to assure the equipment is in safe working condition prior to each usage, and periodically during usage. Engine motor vibration may shake screws and bolts loose during operation.

TROUBLE SHOOTING

Problem	Cause	Solution
Engine will not start.	No gas.	Add gas.
	Faulty spark plug.	Replace spark plug.
	Unit loaded during start up.	Remove load from unit.
Engine will not start. Engine starts but runs roughly.	Low oil level.	Fill crankcase to the proper level. Place log splitter on a flat, level surface.
	Choke in the wrong position.	Adjust choke.
	Spark plug wire loose.	Attach wire to spark plug.
Engine shuts down during operation.	Out of gas.	Fill gas tank.
	Low oil level.	Fill crankcase to the proper level. Place log splitter on a flat, level surface.
Engine cannot supply enough power or overheating.	Insufficient ventilation.	Check for air restriction. Move to a well ventilated area.
Wedge movement is slow or erratic.	Air in the hydraulic oil system.	Purge air by extending and retracting the wedge several times until motion is smooth.
	Debris lodged in beam guides.	Clear debris from beam.
	Low hydraulic oil.	Check oil level and add as needed.
	Hydraulic oil is not continuous.	Add hydraulic fluid.
Oil leak from cylinder.	Faulty cylinder rod seal.	Contact Customer Service.
	Scored or bent cylinder rod.	Contact Customer Service.
	Loose hydraulic fitting.	Tighten hydraulic fitting.
	Faulty combination washer seal on cylinder hydraulic fitting.	Contact Customer Service.
Wedge will not extend or retract.	Faulty control valve.	Contact Customer Service.
	Faulty hydraulic pump.	Contact Customer Service.
	Low hydraulic oil.	Check oil level and add as needed.
Excessive bouncing while towing.	Under-inflated tires.	Inflate tires to proper pressure. Refer to tire sidewall.
The hose is twisted after tightening.	The hose rotates.	Clamp the hose sleeve with pipe pliers and tighten the joint with a wrench
The valve stem springs back multiple times.	There is air in the hydraulic hoses.	Unscrew oil dipstick to vent.



Great Circle USA
 Support Line: 1-866-493-0524
help@greatcircleus.com
www.greatcircleus.com