

POWER-KING[®]

USER MANUAL

MODEL
PK0803



STUMP GRINDER

TABLE OF CONTENTS

Preface.....	3
Safety precautions.....	4
Operations.....	6
Maintenance.....	10
Specifications.	11
Parts list.....	12
Assembling.....	14

PREFACE

Thanks for buying the Stump Grinder, another high-quality machine from our company.

To get the most out of your purchase, please read the manual before using the stump grinder.

We ask you to please read this manual carefully beforehand in order to familiarise yourself with this product and after reading, please store this instructional manual for future reference. Failure to follow the proper protocols listed in the manual may cause personal injury to the operator or damage to equipment.

SAFETY PRECAUTIONS

- Keep the working area clean and well lit.
- Do not operate the stump grinder in the presence of flammable liquids, gases or dust.
- Keep children and bystanders away while operating the stump grinder. Keep the area free of all distractions.
- Only responsible, properly instructed individuals should operate this machine.
- Inexperienced operators must always be carefully supervised.
- Do not expose stump grinders to rain or wet conditions.
- Stay alert, watch what you are doing and use common sense when operating a stump grinder. Do not use a stump grinder while you are tired or under the influence of drugs, alcohol or medication. A moment of inattention while operating any stump grinders may result in serious personal injury.
- Use safety equipment. Always wear eye protection. Safety equipment such as dust mask, non-skid safety shoes, hard hat, or hearing protection used for appropriate conditions will reduce personal injuries.
- Dress properly. Do not wear loose clothing or jewelry. Keep your hair, clothing and gloves away from moving parts. Loose clothes, jewelry or long hair can be caught in moving parts.
- Always wear earplugs to protect your ears.
- Do not start the engine until the machine is in the cutting position next to the stump.
- Do not overreach. Keep proper footing and balance at all times. This enables better control of the stump grinder in unexpected situations.
- If devices are provided for the collection of dust extraction, ensure these are connected and properly used. Use of these devices can reduce dust related hazards.
- Check stumps to be removed for embedded nails, wire, metal fence posts and other metallic objects and for rocks or other buried impediments which may become dangerously thrown or cause unexpected machine movements when hit by the cutting wheel.
- Make sure that all shields and guards are in place and are in good condition prior to operating the machine. Check cutting wheel for damage or missing teeth and replace as necessary.

- Ensure that everyone in the vicinity is aware of the **danger zone** associated with this machine(see diagram). You must avoid the **danger zone** at all times when the machine is in operation.



- Make sure that no-one is working on underneath or close to the machine before starting the engine or beginning to move the machine. Make sure that the area is free of personnel.
- Don't make any alterations or modifications to your stump grinder.
- Check with your local council and utility providers for the locations of buried pipes and cables where applicable, before operating the machine.

FUEL SAFETY

- Pay attention while handling fuel. They are flammable and the vapours are highly explosive.
- Never remove the fuel cap or add fuel with the power running. Stop the engine and allow engine and exhaust components to cool before refueling.
- Do not smoke while adding fuel.
- Fill your engine with 10w-30/ 10w-40/ 15w-30/ 15w-40 non-synthetic engine oil before use or serious damage will occur.
- Use extreme care when handling fuel. Fuel is extremely flammable and the vapors are explosive. Never fuel machine indoors or while the engine is hot or running.
- Never refuel or store the machine in a place where there is open flame, spark or other ignition objects.
- Do not attempt to start the engine if fuel is spilled. Wipe away the spillage and ensure all fuel has dried before starting the machine.
- Always make sure the fuel cap is securely tightened and replace before starting.
- If the fuel tank needs to be drained, it should be done outdoors.

OPERATIONS

ADDING OIL TO THE ENGINE

1. Only fill the fuel tank to a level 15mm lower than the top of the fuel tank. Do not overfill.
2. Use the dipstick to check the oil level. Use 10w-30/ 10w-40/ 15w-30/ 15w-40 non-synthetic engine oil. Fill to the correct level before use.

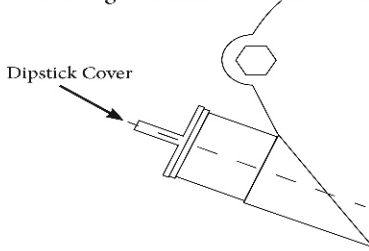

The engine is shipped without oil. Fill to the correct level before use. Operating the engine with no oil or oil at a low level will destroy the engine- this is not covered under warranty.

STARTING THE ENGINE

1. Lock travel wheel by pulling brake lever fully back.
2. Make sure throttle is in slow position.

Do not allow the rope to snap back, return it by hand to prevent damage to the starter.

3. If the engine is cold, move the choke lever to the closed position.
4. Raise the cutter wheel 4 to 5 inches off the ground by pushing downwards on the handle bar, hold it in that position.

The next step may cause the cutter wheel to rotate, keep everyone away.

5. Pull the starter rope lightly until resistance is felt then pull briskly.
6. Move the choke lever to the open position.

The next step causes the cutter wheel to rotate, keep everyone away.

7. Move the throttle to fast. if the engine is cold, allow the engine to idle(throttle set to slow) for a few minutes before cutting.

REMOVING STUMPS

- Remove all loose pieces of wood, stones, wire and other debris from the area before beginning stump removal.
- Wind direction should be considered, as it influences the direction in which dust and wood chips are directed.
- Never operate the grinder after dark. There will be no adequate light for the operator to use the grinder safely.
- Always allow a cold engine time to warm up before cutting a stump.
- Only the portion of cutting wheel within the 80 degree area shown above should engage the stump. Never undercut the stump or use the bottom of the cutting wheel for cutting purposes.

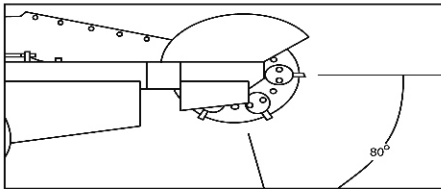

- Never leave controls when the cutting wheel is rotating.

Operating Tips!

- Use smooth, comfortable side to side movements while operating.
- When it is desired to cut smaller roots, it may be more effective to do so before rather than after cutting the stump.
- Should the chip build-up become excessive when cutting, shut off the machine, wait for the cutting wheel to stop rotating, retract the machine from the stump and rake away the chips. It is also possible to use the cutter wheel to push chips off to the side.
- **In order to prevent any of the wheels becoming stuck in the hole. Move the grinder to the other side of the stump to continue removal or by filling the hole with chips before continuing.**

Prepare the grinder at the stump.

Place it into position with the cutting wheel near the top edge of the stump.

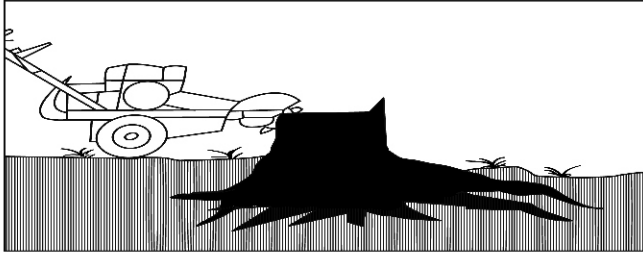

Removing roots

1. Make sure the throttle is set to **fast**, the cutter wheel will accelerate to cutting speed.
2. Swing the cutting wheel to one side, then lower it into the nearest roots that are buried at the foot of the stump.
3. Swing the cutting wheel before each sweep, until the roots are sufficiently removed.

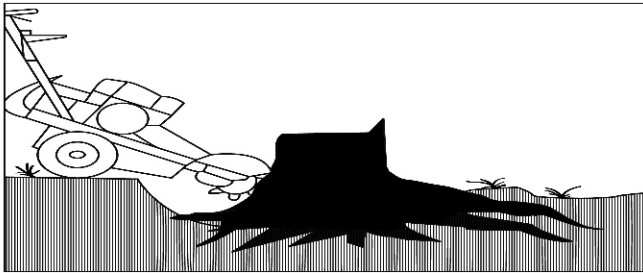

4. Raise the cutting wheel until the centre of the cutting wheel is just above the top of the stump.
5. Allow the cutter wheel to stop, release the brake and reposition the machine.
6. Lock the brake again.

Cutting the full stump

1. Make sure the throttle is set to **fast**. The cutter wheel will accelerate to cutting speed.
2. Direct the cutter wheel against the stump, beginning with the nearest top corner of the stump, and steadily sweep it across the stump left and right, cutting away 1/2 inch of wood with each sweep.
3. Raise and lower the cutter wheel between sweeps by lowering and raising the control handle.
4. Roll the machine forward and back, by pushing and pulling on the control handle. To do this, release the brake. Relock it when the machine has been repositioned and continue cutting.

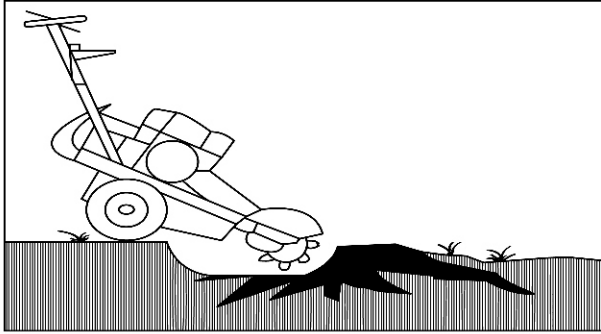

Continue with final roots removal

Cut the remaining roots as described in STEP 2 until satisfactorily removed

SHUTTING OFF THE GRINDER

1. When stopping the machine after normal operation, lower engine speed to **slow**, and push the emergency switch.
2. Set park brake before leaving the controls.
3. **Shut off the engine by pushing the on/off switch.**

NORMAL SHUTDOWN PROCEDURE

In consideration of your own safety and that of others, you should always use the following normal shutdown procedures before departing from the controls for any reason including cleaning, servicing, transporting or inspecting the stump grinder. Never deviate from this procedure unless so instructed in this manual or in an emergency that requires it.

⚠ A rotating cutting wheel is very dangerous. Stand at controls and ensure that the cutting wheel comes to a complete stop before doing anything else.

1. Move the engine throttle to the **slow** position.
2. Push the emergency (on/off) switch to stop the engine.
3. Set park brake before leaving controls.

EMERGENCY SHUT DOWN PROCEDURE

1. Immediately push the emergency (on/off) switch for the engine will be shut off.
2. Be sure to allow all moving parts to come to a complete stop.
3. Pull the brake lever to engage the brake.
4. Rectify the emergency situation and return to normal operation.

MAINTENANCE

- Make sure all nuts, bolts and screws are tightened.
- Never store the equipment with petrol in the tank inside a building where fumes can reach an open flame or spark. Allow the engine to cool before moving the grinder.
- To reduce fire hazards, keep the engine and petrol storage area free of grass, dirt and excessive grease.
- Replace worn or damaged parts for safety. If the fuel tank has to be drained, this should be done outdoors.
- Regularly check the oil level and add some oil or replace it if necessary.
- Frequently check the grinder and ensure that all bark and dirt deposits are removed from beneath the deck.
- Lubricate the wheel axle and the bearings with grease regularly.
- Check the cutting wheel often. In order to achieve clean work the blade should always be sharp and well balanced.
- Check the tightening of all bolts and screws at regularly intervals. Nuts and bolts that are worn out or badly tightened can damage the engine or the frame.
- If the grinder hits an obstacle violently, stop the grinder and take it to a specialist for inspection.

TRANSPORTATION

The stump grinder is designed to be transported via a van or small trailer. The machine is equipped with grab bars that are to be used for both lifting the machine, and strapping it down. This machine weighs approximately 110kg and should only be lifted using correct apparatus or an adequate number of people working as a team.

The are legal road requirements for towing equipment and trailers(such as lighting and licensing).It is the owner's responsibility to be aware of these laws and to adhere to them.

SPECIFICATIONS

Diameter of Cutting Wheel: 12 Inches

Cutting wheel thickness: 3.5 Inches

Cutter Depth Below Ground: 9 Inches

Cutter Depth Above Ground: 10 Inches

Width of the machine: 30 Inches

Qty of Teeth: 9PCS

tyre size: 13"

Brake: Drum Brake

Belt: two pcs V belt

Engine Type: OHV 4-stroke

Starting System: Recoil

Max. Output: 14HP/3600rpm

Fuel Type: Unleaded Gasoline

No.	spare part	Quantity	No.	spare part	Quantity
86	Rocker	1	43	Nylon locknut	25
85	Flat Washer	11	42	Inclined spacer	1
84	Hexagon socket screw	2	41	Short layering	1
83	Inner mounting plate	1	40	Deputy belt cover plate	1
82	Step bolt	4	39	belt	2
81	Throttle Cable	1	38	casing	2
80	Throttle switch	1	37	Flat key	1
79	Emergency stop switch	1	36	Left tire	1
78	safety rope switch	1	35	Hex bolt	1
77	handrail	1	34	Hex bolt	1
76	handrail support	1	33	Chassis assembly	1
75	Spring washer	1	32	Belt cover	1
74	Hand sets	1	31	Hexagon socket screw	1
73	Angle adjustment knob	2	30	Small spacer	1
72	Flat Washer	2	29	Large pulley	1
71	Hex bolt	2	28	Edge spacer	1
70	Nylon locknut	2	27	Hex bolt	1
69	Flat Washer	1	26	Left Cutter	3
68	Hex bolt	2	25	Straight Cutter	3
67	Connecting plate	2	24	Right Cutter	3
66	spacer sleeve	2	23	Cutter plate	1
65	Liner	1	22	Hexagon socket screw	
64	Axle pin	1	21	Flat Washer	30
63	Connecting pipe	1	20	Spring washer	9
62	Threaded rod	1	19	Nylon locknut	19
61	Hex round head bolt	3	18	The spacer	2
60	lid	1	17	Nylon locknut	8
59	The handbrake	1	16	Spring washer	8
58	Shaft Collar	1	15	Power holding board	1
57	Outer mounting plate	1	14	Vertical Bearing	2
56	Hexagon socket screw	4	13	Big Washer	2
55	Cylindrical spring pin	3	12	Hexagon socket screw	1
54	Adjustment screw	1	11	Long spacer	1
53	Handbrake cable	1	10	Long layering	1
52	Brake	1	9	Flat Washer	44
51	Flat washer come with Engine	1	8	Hex round head bolt	21
50	Engine Bolt	1	7	Cutter shield	1
49	Handbrake cable adjusting bolt	1	6	Flat Washer	12
48	Clutch pulley	1	5	Hexagon socket screw	4
47	Partition panel	1	4	Flat Washer	2
46	Engine spacer	1	3	Nylon locknut	2
45	Handle	2	2	The right Tire	1
44	Hexagon socket screw	4	1	Engine	1

Assembling

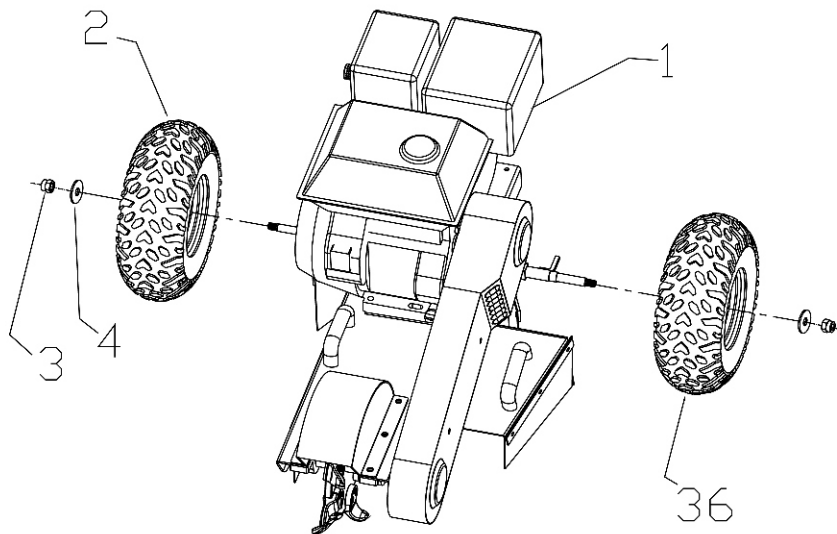

1	2	3	4	36
engine	wheel	Nylon anti loose nut	flat washer	wheel

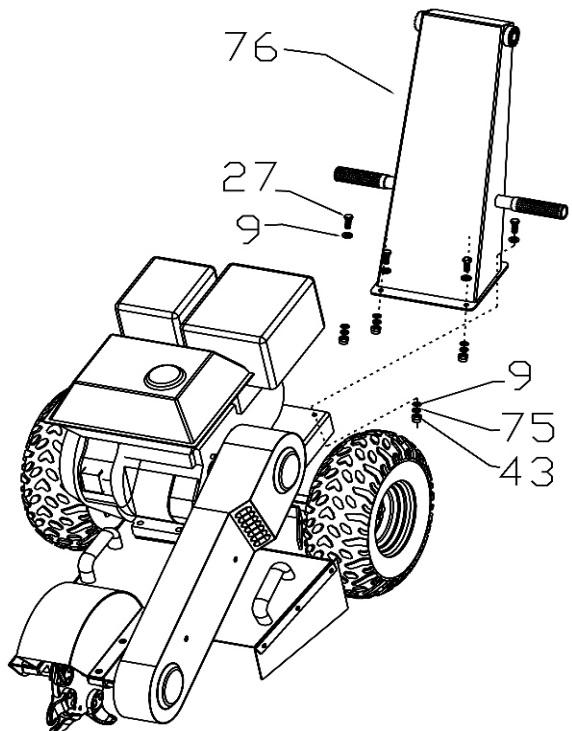

9	27	43	75	76
flat washer	outer six angle bolt	Nylon anti loose nut	spring washer	arm handle

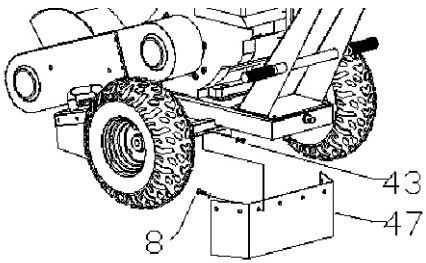

8	43	47
Bolt	lock nut	leather protector

Assembling

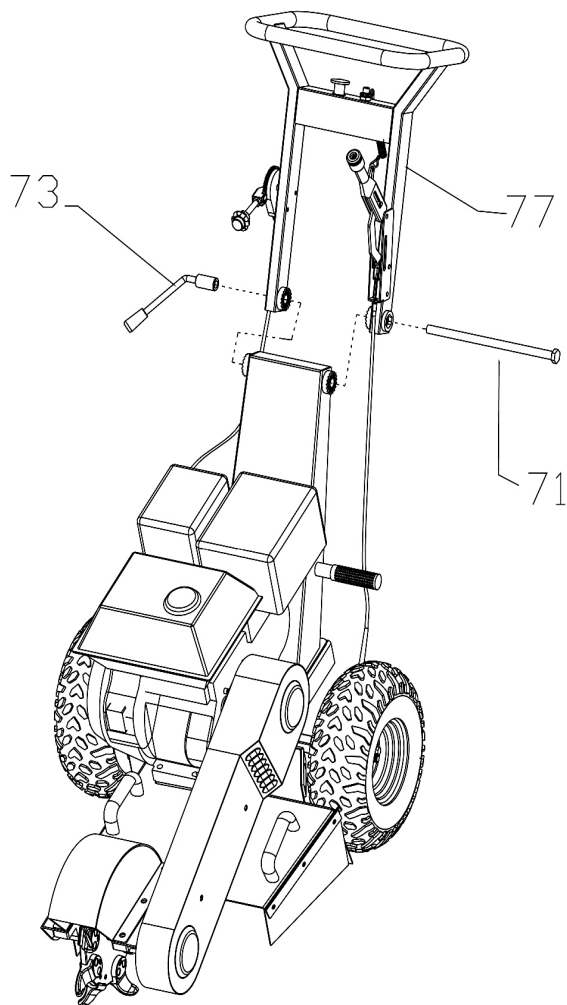

71	73	77
outer six angle bolt	Adjustable handle bar	handle

Remark:
connect the engine wires like this:



drop down the stand in storage.



Optional choice

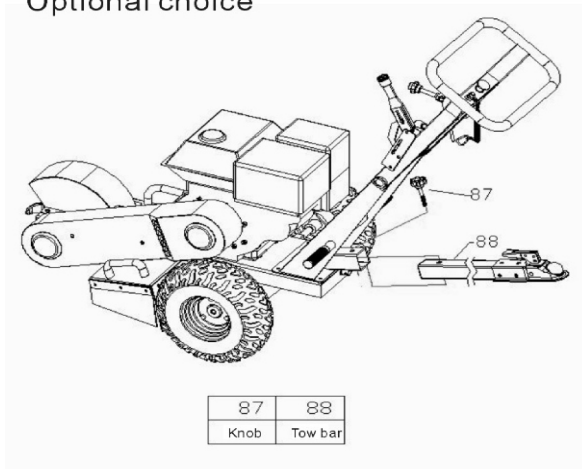

POWER KING® QV POWER QV Tools™

RETURN / WARRANTY POLICY

Thank you for choosing QVTOOLS Products. We're here to ensure that your experience is perfect.

In some rare instances, you may need some help with a warranty claim please call us at 1-800-344-3371.

Engine Warranty

Kohler engines are covered with a 3 year commercial warranty for command pro series. Parts and Labor are covered.

Power King engines by Lifa are covered with a 3 year residential warranty. 1 year commercial warranty. Parts and Labor are covered.

QVpower 3pt 40hp gear box warranty 1 year, Visit your engine manufacture for warranty details or visit www.QVtools.com

Equipment warranty

Manufactures defects of chassis and components parts are covered for 30 days. Parts only are covered.

QVtools will repair or replace at its' option, any part that is proven to be defective in material or workmanship. This warranty is not valid for products or parts affected or damaged by accident, collision, normal wear, fuel contamination, abuse, neglect, misuse, alteration and/or unsuitable use or unauthorized parts replacement. Transportation charges to and from service centers if assigned is not covered. Shipping cost of product for repair is not covered. Labor to repair equipment is not covered. Parts not covered under warranty are: belts, springs, tires and rims, chainsaw chains, bars, carburetors, and electronics. Equipment cutting teeth and blades, throttle and throttle cables, brakes, and cables. Power King has all replacement parts at value pricing for replacement parts needed.

Damaged Products

You must take the time to inspect the goods before you sign the delivery receipt from the carrier. If you sign the delivery receipt without inspecting the shipment you will be responsible for filing a freight claim and arranging for a repair or return of the damaged goods.

Concealed damage claims must be reported immediately.

Suspect Damage

On occasion, the outer carton may look damaged, but the product inside the box is perfectly fine. If you suspect concealed damage, **notate "Possible Freight Damage" on the delivery receipt while the driver is present.** This way, if you discover later that the product is damaged, the remedy of a freight claim is less of a hassle.

Obvious Damage

Do not sign for damaged products. If your product arrives damaged, please **(a) REFUSE DELIVERY** and **(b) Call where you purchased the item immediately** so the dealer can process the appropriate claims and coordinate an exchange for you.

Defective Products

We encourage you to test your product within 15 days of receipt so we can quickly remedy any mechanical problems. If you think your product is defective, don't worry.

In most cases, it's a simple issue that can be resolved over the phone. You are also welcomed to contact QVTOOLS customer service departments. They have expert technicians standing by to help solve your issue. Please have your model number and serial number available and your proof of purchase receipt for fastest service.

Original owner warranty

Warranty is non-transferable and covers the original owner only who purchased from a QVTOOLS authorized dealer.

This revised warranty is in effect for all products purchased after August 31st, 2017.

QVTOOLS, LLC 2731 CRIMSON CANYON DRIVE, LAS VEGAS, NV. 89128 1-800-344-3371