

BRAVE

MBRPT9SH

MODEL(S):
BRPT9SH

ITEM NUMBER: _____

SERIAL NUMBER: _____

Owner's Manual

Instructions for Assembly, Testing, Operation,
Servicing and Storage

BRPT9SH BED SCULPTOR/TRENCHER

WARNING

READ and UNDERSTAND this manual completely before using trencher.

All operators of this equipment must read and completely understand all safety information, operating instructions, maintenance and storage instructions. Failure to properly operate and maintain the trencher could result in serious injury to the operator and bystanders from moving parts that can crush or cut, flying objects, burns, fire or explosion or carbon monoxide poisoning and be aware of the following hazards.

- **WARNING:** Do not operate machine without rotor hood installed and secure.
- **WARNING:** Do not operate the machine within a 50' radius of people, animals, automobiles or glassed areas which might be damaged or hurt by projectiles.
- **WARNING:** Operator must wear eye protection when operating the machine.
- **WARNING:** Operator must locate and stay clear of all underground gas, electric, water and communications lines before starting trenching operation.
- **WARNING:** Starting the trencher is the most critical time for dangerous flying projectiles. Be especially cautious by policing the area for rocks or other possible projectiles and ensure the area is completely clear of people, animals, vehicles, etc. that may be damaged by projectiles.
- **WARNING:** If trencher strikes an underground object, STOP immediately to determine the object. Investigation should be done visually since touching an exposed wire could be fatal.

STOP!

ADD OIL TO ENGINE BEFORE USING: Engine is shipped without oil. DO NOT start Trencher without first adding oil.

INSPECT COMPONENTS: Closely inspect to make sure no components are missing or damaged.

See Initial Unpacking and Set-up for instructions and for whom to contact to report missing or damaged parts.

Any Questions, Comments, Problems or Parts Orders
Call Brave Product Support 1-800-350-8739

BRAVE

INTRODUCTION

You are now the owner of a Brave Trencher. The trencher is versatile, which when properly equipped, will trench in almost any soil condition. The trencher is an inexpensive alternative to the much heavier, more bulky, and less maneuverable trenchers on the market.

If you have any questions or problems with your Trencher, please contact your dealer or distributor. If they cannot answer your questions, or solve your problem, feel free to call: 800-350-8739

BRAVE

20195 S. Diamond Lake Rd., STE 100, Rogers, MN 55374

(800) 350-8739 • Fax: (866) 779-9963

www.braveproducts.com

01/2018



Dear Valued Customer:

The Brave product you just purchased is built with the finest material and craftsmanship. Use this product properly and enjoy the benefits from its high performance. By purchasing a Brave product, you show a desire for quality and durability. Like all mechanical equipment this unit requires a due amount of care. Treat this unit like the high quality piece of machinery it is. Neglect and improper handling may impair its performance.

Thoroughly read the instructions and understand the operation before using your product. Always contact Brave Product Support at 1-800-350-8739 prior to having any service or warranty work performed, as some services performed by parties other than Brave approved service centers may void this warranty. This limited warranty is in lieu of any other warranty expressed or implied, written or oral and Brave assumes no other responsibility or liability outside that expressed within this limited warranty.

Limited Warranty for Brave Trenchers:

		Models:	
		BRPT	BRPT704H
		BRPT9SH	BRPT4H
		Consumer Warranty Period	
		Commercial Warranty Period	
Weldments		2 years from date of purchase by user	
Wear Parts		2 year from date of purchase by user	
Engines		In addition to the normal warranty, Brave shall warrant some normal wear items from defects in material or workmanship for a period of 30 days from the date of purchase by user. Normal wear items covered under this warranty are limited to: High impact wear related components such as standard retention hardware for wear items, chains, bits, sprockets, bearings, belts and bushings, centrifugal clutch components such as shoes, springs, drum and rotor assembly, rotors, rubber drapes or flaps, drive and driven pulleys. Routine maintenance items such as lubricants, clutch adjustments, tune ups are not covered under warranty.	
		The engine warranty is covered under the terms and conditions as outlined by the engine manufactures warranty contained herein and is the sole responsibility of the engine manufacturer. Normal engine maintenance such as spark plugs, oil changes, air filters, adjustments, fuel system cleaning and obstruction due to build up is not covered by this Brave limited warranty.	

“Consumer use” means personal residential household use by a consumer. “Commercial use” means all other uses, including, but not limited to, use for commercial, income producing or rental purposes or when purchased by a business.

This limited warranty applies to the original purchaser of the equipment (verification of purchase, in the form of a receipt, is the responsibility of the buyer), is non-transferable, and covers parts and labor. Parts will be replaced or repaired at no charge, except when the equipment has failed due to lack of proper maintenance. If a part is no longer available, the part may be replaced with a similar part of equal function. Any misuse, abuse, alteration or improper installation or operations will void warranty. Determining whether a part is to be replaced or repaired is the sole decision of Brave. Brave will not provide for replacement of complete products due to defective parts. Any costs incurred due to replacement or repair of items outside of a Brave approved facility is the responsibility of the buyer and not covered under warranty. Transportation costs to and from service center and/or service calls are the responsibility of the customer.

This limited warranty specifically excludes the following; failure of parts due to damage caused by accident, fire, flood, windstorm, acts of God, applications not approved by Brave in writing, corrosion caused by chemicals, use of replacement parts which do not conform to manufacturer’s specifications, damage related to rodent and/or insect infestation and damage caused by vandalism. Additional exclusions: loss of running time, inconvenience, loss of income, or loss of use, including any implied warranty of merchantability of fitness for a specific use. Also, outdoor power equipment needs periodic parts and service to perform well, and this limited warranty does not cover instances when normal use has exhausted the life of a component or the engine.

This limited warranty does not cover any personal injury or damage to surrounding property caused by failure of any part, misuse or inability to use the product. Alteration of the product, including safety features, shall void this limited warranty.

Repair or replacement of parts does not extend the warranty period. This limited warranty gives you specific legal rights. You may also have other rights that vary by state. Please have model number, item number and serial number on hand prior to making a warranty claim or inquiry.

For products purchased on or after January 1, 2018



**Brave
Product Registration Form**

YOUR INFORMATION

Full Name:

Last First M.I.

Address:

Street Address Apartment/Unit #

City State ZIP Code

Home Phone:

**Alternate
Phone:**

Email

PURCHASED FROM

Company:

Address:

Street Address Apartment/Unit #

City State ZIP Code

MODEL INFORMATION

Purchase Date

Application Type

Homeowner

Commercial

Rental

Model (i.e. BRPT704H)

Serial # (i.e. 123456)

Signature

Register your product online at www.braveproducts.com

TABLE OF CONTENTS

1.	Getting Acquainted With Your Brave Trencher	1-1
2.	Safety Precautions	2-1
3.	Operating Instructions	3-1
4.	Scheduled Maintenance	4-1
5.	Trouble Shooting	5-1
6.	Equipping the Trencher for Varying Conditions	6-1
7.	BRPT9SH INFORMATION Assembly	
	Instructions	7-1
	Parts Information	7-2

GETTING ACQUAINTED WITH YOUR BRAVE TRENCHER

FIGURE #1

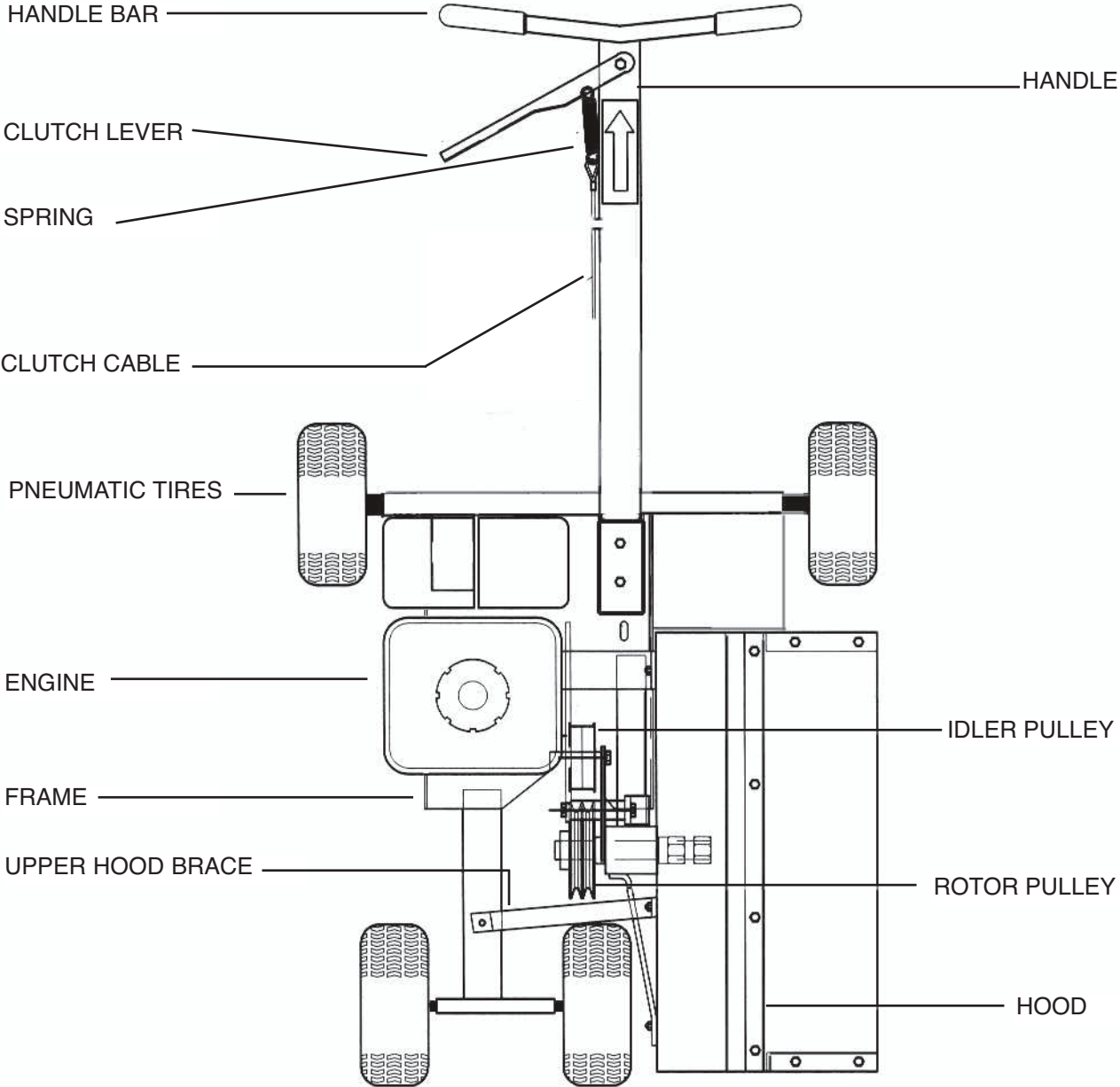



WARNING

SAFETY PRECAUTIONS



WARNING: Engine exhaust from this product contains chemicals known, in certain quantities, to cause cancer, birth defects, or other reproductive harm.

DO NOT assemble trencher before reading assembly instructions.

DO NOT start trencher before reading operating instructions.

DO NOT modify trencher in any way.

DO NOT operate without all shields in place.

DO NOT operate without eye protection. Goggles are provided with each Trencher

DO NOT lift trencher off the ground until engine is switched off and rotor has stopped.

DO NOT drop the trencher to the ground from truck tailgate or bed of trailer.

DO NOT operate unless safety area is clear of people, animals, vehicles, and glassed areas that may be damaged by possible projectiles. (See Soil & Debris Exhaust chart showing areas of possible projectiles.)

DO NOT begin operation until all underground pipes, electrical and communications lines and sprinkler lines have been located and marked. The utility companies will be glad to provide information on their facilities. A ruptured gas line or cut electrical cable may cause injury or death.

DO NOT place hands or feet near belts or rotor mechanisms while engine is running.

DO NOT operate trencher without wearing proper shoes (high top leather shoes or boots are recommended).

DO NOT allow bystanders or spectators to be within 50 feet of trencher while engine is running. (See Soil & Debris Exhaust chart showing areas of possible projectiles).

DO NOT operate trencher until all surface obstructions have been cleared from area. All rocks and debris should be removed from the area.

DO NOT disconnect oil alert on engines. To do so may void your engine warranty.

**TRENCHER
SOIL & DEBRIS EXHAUST CHART**

FIGURE #2

SAFETY PRECAUTIONS

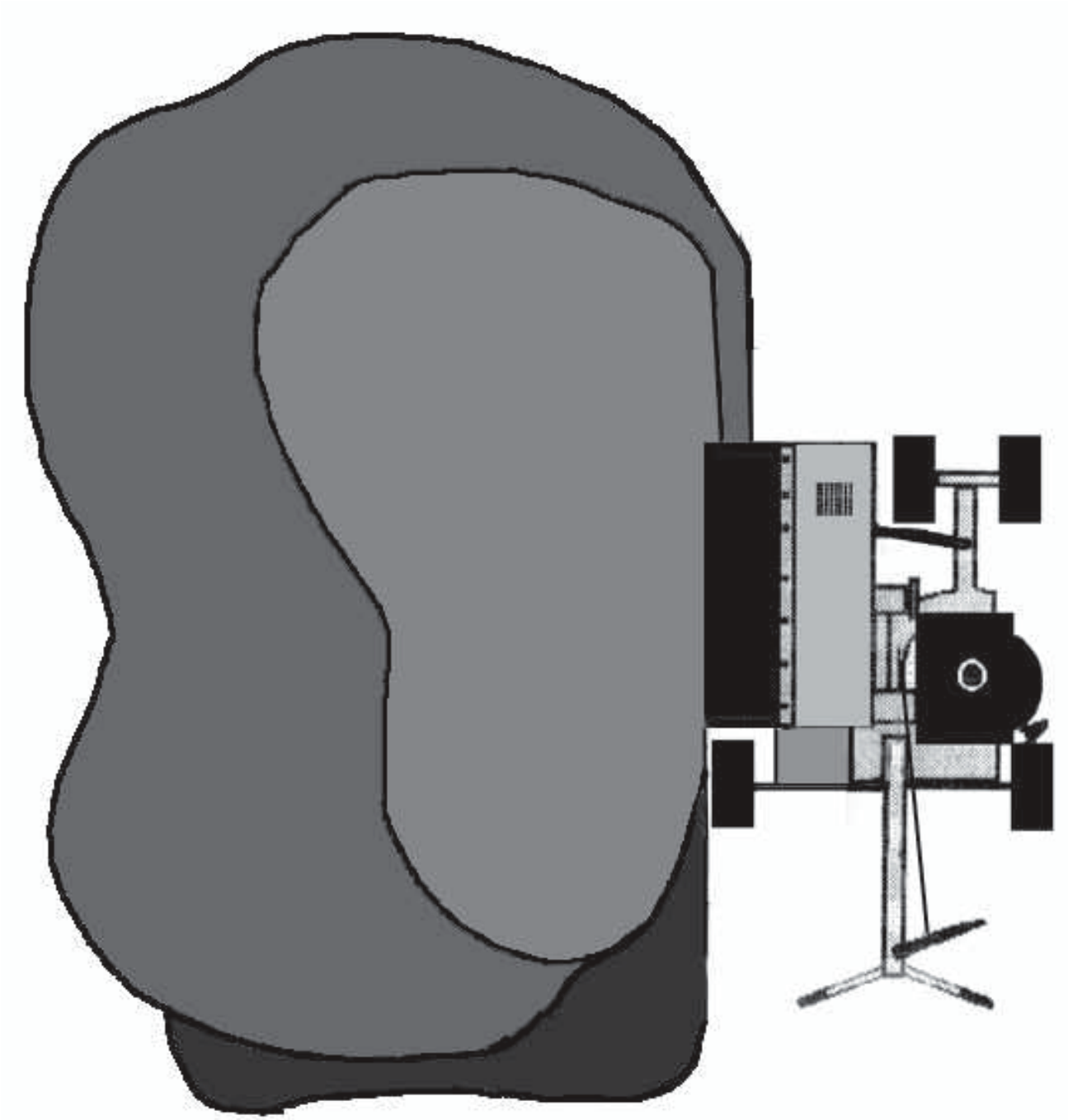

OPERATING INSTRUCTIONS

Brave Trencher

BEFORE STARTING ENGINE

1. Check machine
 - a. Read and be familiar with equipment operating instructions.
 - b. Be sure you have the proper rotor for trench size and soil conditions. (See equipping your trencher for varying conditions, Page 6-1.)
 - c. Check rotor retaining nut for tightness. (See Assembly Instructions)
 - d. Be sure belts and pulleys are properly aligned and adjusted.
 - e. Check hood mounting bolts and nuts for tightness.
 - f. Check set screws in pulleys & lock collars for tightness.
 - g. Check all other nuts and bolts for tightness.
 - h. Check Clutch Cable tension. Tension is adjusted using the turnbuckle so that the clutch spring stretches approximately 3/4" to 1" for 9" models when the clutch lever is completely engaged.
 - i. If your trencher is equipped with a rock rotor, the points must be loose and free to rotate. There should be 3/32" - 1/16" clearance between nut and point socket. (See Illustration on page 3-3.)
2. Check machine



CAUTION: NEW ENGINES SHIPPED WITH MACHINES ARE NOT SERVICED. ADD OIL TO CRANKCASE BEFORE STARTING.



WARNING: Gasoline is extremely flammable and highly explosive under certain conditions. Always stop the engine and do not refill tank while you are smoking or near open flame or sparks.



WARNING: Never start or run the engine while in an area where fumes may collect. Carbon monoxide from the exhaust is an odor less and deadly gas which must have adequate space or ventilation to allow rapid dispersal.

-
- a. Be familiar with manufacturer's operating and safety instructions for engine.
 - b. Check oil level with dipstick and add if necessary. Do not overfill.
 - c. Check air filter and clean if necessary. Clean frequently if operating in dusty conditions.
 - d. Use only clean fuel. Unleaded fuel is recommended in all engines.
 - e. Be sure muffler and exhaust deflector are installed, are in proper position, and are in good operating condition. (Deflector should exhaust to left, away from the air intake.)
3. Start engine
 - a. Be sure clutch lever is in disengaged position and no tension is on drive belts.
 - b. Turn ignition switch to "ON" position.
 - c. Close choke if engine is cold.

Starting Engine Continued

- d. Pull start cord rapidly.
- e. When engine starts, gradually open choke and let engine warm up at about 1/4 speed.



WARNING: Do not operate machine without rotor hood installed and secure.



WARNING: Do not operate the machine within a 50' radius of people, animals, automobiles or glassed areas which might be damaged by projectiles.



WARNING: Operator must wear eye protection when operating the Brave Trencher.



WARNING: Operator must locate and stay clear of all underground gas, electric, water and communications lines before starting trenching operation.

CALIFORNIA PROPOSITION 65 WARNING: Engine exhaust from this product contains chemicals known to the State of California to cause cancer, birth defects, or other reproductive harm.

4. Operation

- a. **To start trenching, set throttle full open.** Before engaging the clutch lever, the handle must be pushed toward the ground enough to allow the rotor to turn without hitting the ground. When rotor attains operating speed, the handle should be raised slowly so that the rotor engages the ground and gradually digs to trench depth.
- b. When trench depth is achieved, the operator should **pull the machine to the rear** at such a speed that the trencher will dig without overloading the engine.



WARNING: Starting the trench is the most critical time for dangerous flying projectiles. Be especially cautious by policing the area for rocks or other possible projectiles and ensure the area is completely clear of people, animals, vehicles, etc. that may be damaged by projectiles.

-
- c. When trenching, **if trencher strikes an underground object, stop immediately** to determine what the object is. Investigation should be done visually since touching an exposed electric wire could be fatal.
 - d. When trencher strikes a rock either the trench or rock should be moved unless your trencher is equipped with the rock rotor. If it has the rock rotor, then proceed slowly with a constant pressure against the rock. If the rock doesn't begin to crush or move after a few seconds, it may be necessary to remove the rock because the rock rotor can't cut through rock requiring more than 10,000 P.S.I. to crush.
 - e. When digging in extremely hard clay or other difficult soils, it may sometimes be necessary to use an oscillating action by applying and releasing pressure on handlebar, front to rear, alternately.

OPERATING INSTRUCTIONS (CONTINUED)

NOTE: Use the smallest rotor possible when trenching in hard clay, rocky or other difficult soils. Most cable TV or satellite dealers use a 4" or 5" deep rotor instead of the 7". By using a smaller rotor you may trench faster, you have less dirt to clean up and the rotors will last longer.

- f. As a safety consideration, where the soil has a large content of gravel and small rocks, it may be necessary to dig a hole by shovel to start the trench. This may preclude property damage or an injury from flying debris. (This would apply when near buildings or populated areas).
- g. If you encounter an unusual vibration when trenching, stop and shut off the engine immediately. Inspect to make sure that a point has not been broken. If a point is missing or broken, replace the point if it is a rock rotor or replace the rotor if it is a clay rotor.
- h. When installing points on rock rotors, the points must be loose and free to rotate to prevent uneven wear and breakage. The flat nut must go on first. When the flat retaining nut is tightened to the end of the threads there should be a gap of $1/16"$ to $3/32"$ (thickness of a nickel) between the socket and the flat nut. Use two wrenches to jam the lock nut against the flat retaining nut. See diagram below.

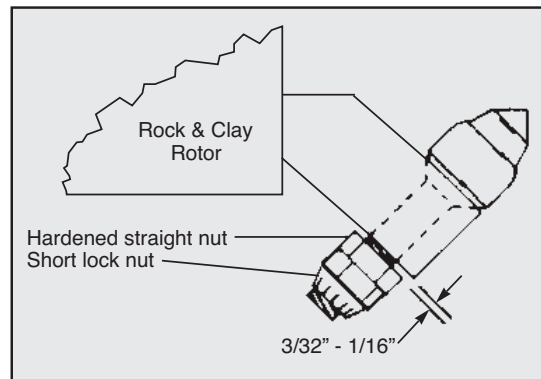

- i. The diagram below provides guidance for positioning components when replacing spindle, bearings or pulley on all models.

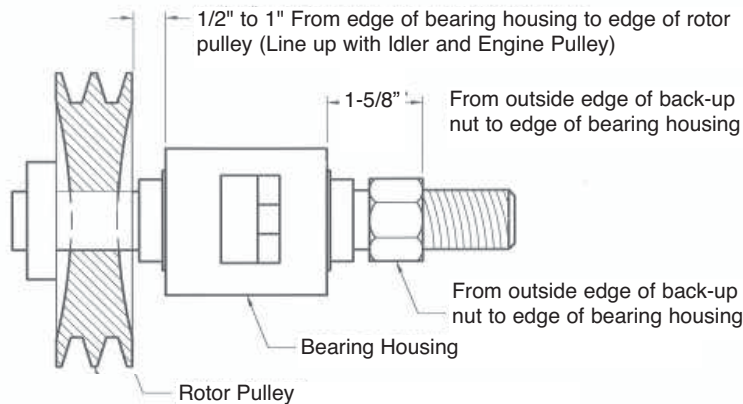

- j. Bearing and/or Spindle replacement - To replace the spindle and bearings it is advisable to remove the clay hood. Before loosening the lock collars you must remove the rotor pulley. The pulley is cast iron and is easily broken if impacted on the outer edges. Use a hammer and punch (or $3/4"$ bolt) against the thick center portion of the pulley. Soaking with penetrating oil will help. When the pulley is removed, loosen the set screws on the lock collars. Drive the shaft out from the pulley side. The back-up nut on the spindle is fixed and should not be loosened. Each bearing seats against a shoulder in the housing. They must be removed by placing a punch through the housing from the opposite side.

HOW TO INSTALL THE SELF-LOCKING COLLAR

The Self-Locking Collar originated in 1925. It was designed to facilitate the mounting of wide inner ring ball bearings by eliminating the need for locknuts, washers, shoulders, sleeves and adapters. This collar made the wide inner ring ball bearings easiest of all to install. The inside of the locking collar has a counter-bored recess which is made eccentric with the bore. The collar and the end of the bearing inner ring with which it engages are both machined to act as mating cams on the shaft. When the collar is engaged to the inner ring, it grips the shaft tightly with a positive binding action that increases with use. No adjustments of any kind are necessary and it is impossible to cramp or overload the bearing in mounting.

-
1. Observe cam design of wide inner ring and self-locking collar. use the punch in the unthreaded hole.

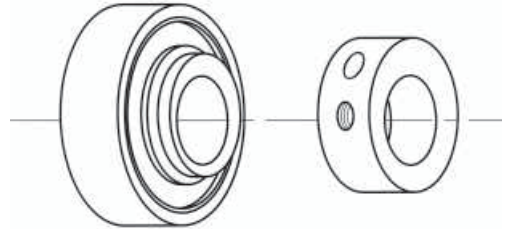

-
2. Mate cam of collar with cam of bearing inner ring.

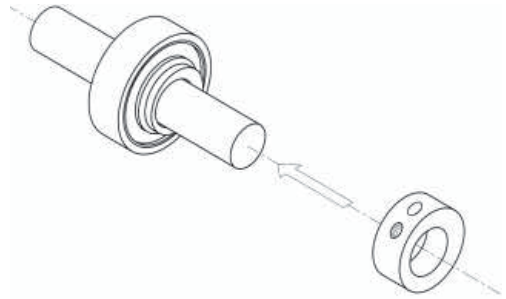

-
3. Pressing collar lightly against inner ring, turn collar **in direction of shaft rotation** until engaged.

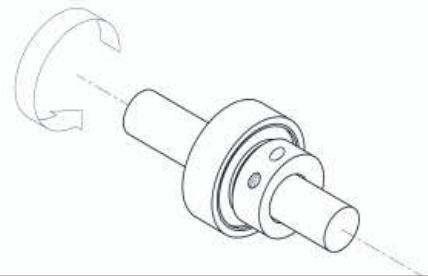

-
4. With drift pin in collar hole, strike **in direction of shaft rotation** to lock.

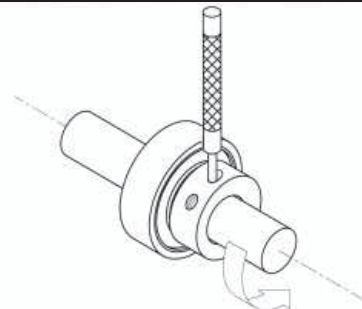

-
5. Tighten set screw in collar **after applying Locktite Threadlocker #242 to the set screw threads.**

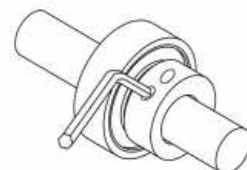

SCHEDULED MAINTENANCE

Good maintenance practices are critical if you are to enjoy trouble free operation and long life from your Brave Trencher. Most required maintenance procedures are shown in this section. However, other common sense maintenance practices such as cleanliness and storage must be followed.

1. See manufacturers operating and maintenance instructions for engine maintenance procedures.
2. Check all bolts and nuts for tightness before operation and periodically thereafter.
3. Check all set screws in belt pulleys and bearing lock collars before operation and periodically thereafter. If set screws are vibrating loose, Loctite's "Threadlocker" #242 should be applied to the threads and the set screws retightened.
4. Check drive belts for proper tension before operation. Adjust if necessary. Adjust belt tension using the turnbuckle to ensure the spring stretches approximately 3/4" to 1" for 9" models when clutch lever is engaged. Keep belt free of dirt and grease at all times.
5. Rotor points must be checked for wear before operation and periodically thereafter. Check at least every 200 feet initially. When working in difficult soil conditions, they should be checked more often. In good soil conditions, they may be checked less often but never less than each 500 feet of trenching.
6. Check rock rotors before operation and periodically thereafter. Points on the rock rotors should be loose in the socket and should rotate freely to prevent uneven wear or breakage. The nut on the point should have between 1/16" and 3/32" clearance (a nickel is 1/16" thick) between the nut and the socket (See Figure on page 3-3)
7. Check rotor bearings for wear every 2000 feet. This is done by lifting the front of the machine off the ground so that the rotor may be turned by hand. Then grasp the end of the rotor firmly and try to move it from side to side. If there is more than 1/4" movement from side to side, the bearings must be replaced.
8. Check the idler pulley for wear before operation and replace if necessary.
9. Periodically check the idler arm for lateral movement. If the pivot bolt is badly worn, or the bolt is loose, the idler arm may have enough lateral movement to cause the belts to come off the pulley. The pivot bolt should be tight enough to prevent lateral movement, but not so tight that it restricts free pivoting of the idler arm.
10. See page 3-4 for instructions on how to use the eccentric lock collar on rotor bearings.

TROUBLESHOOTING

PROBLEM	POSSIBLE CAUSE	SOLUTION
Burning belts	Improper tension on belts	Adjust belt tension Using the turn buckle on the clutch cable. Spring should stretch approximately 3/4" to 1" when clutch lever is fully engaged.
	Pulleys not aligned	Align pulleys
	Pulleys worn excessively	Replace pulleys
	Pulleys broken or burrs on pulley	Replace pulleys
	Wrong type belts	Replace with industrial belts
Excessive vibration	Rotor bearings worn excessively	Replace bearings
	Rotor points broken or missing	Replace points or rotor
	Rotor bent	Replace rotor
Rotor striking	Rotor too close to hood	Loosen eccentric lock collars on spindle and move rotor away from hood. CAUTION: Use thread lock on all set screws and tighten securely. (See page 4-1, Paragraph 3)
	Eccentric lock collars loose	Tighten eccentric lock collars and secure set screws with thread lock. (See page 3-4)
	Rotor bent	Replace rotor
	Nuts on point loose	Align points and tighten nuts.
Pulleys coming off shaft	Pulley set screw not tight	Remove set screws and apply thread lock to set screws then tighten very firmly.
	Eccentric lock collars set screws not tight	Remove set screws from eccentric lock collars, reset lock collars, apply thread lock and tighten very firmly. (See page 3-4)
	Eccentric lock collars worn excessively	Replace eccentric lock collars (See page 3-4)

EQUIPPING YOUR TRENCHER FOR VARYING CONDITIONS

There are several options available which enable you to adapt your trencher to perform well under varying conditions.

The most common conditions requiring special adaptation are listed below and recommended options are listed with each condition.

1. Soil type

- a. Sand, sandy loam, swampy & river soils - Use clay rotor.
- b. Sticky clay or wet soils - Use clay rotor.
- c. Rock, stone & heavy gravel - Use rock rotor.
- d. Scattered rock, small gravel, asphalt and hard clay - Use clay rotor.

SPECIAL NOTE: Rock rotor points should not be used in sand. Sand may jam the points and cause extremely rapid wear.

2. Soil moisture

- a. Wet sand and damp abrasive type soils - Use the clay rotor.
- b. Wet clay or wet heavy soils & any soil that is adhesive or cohesive - Use the clay rotor.

3. Depth and width of trench

Choose the smallest trench that is practical for the job. Digging a smaller trench will save you time and money in three ways:

- a. You will be able to trench faster.
- b. You will have less soil to clean up.
- c. your digging rotors will last longer.

4. Root Pruning - Use root pruner rotors.

5. Selecting the proper rotor for your trencher (See the rotor compatibility list on page 10-1)

ASSEMBLY INSTRUCTIONS DIAGRAM For Models BRPT9SH

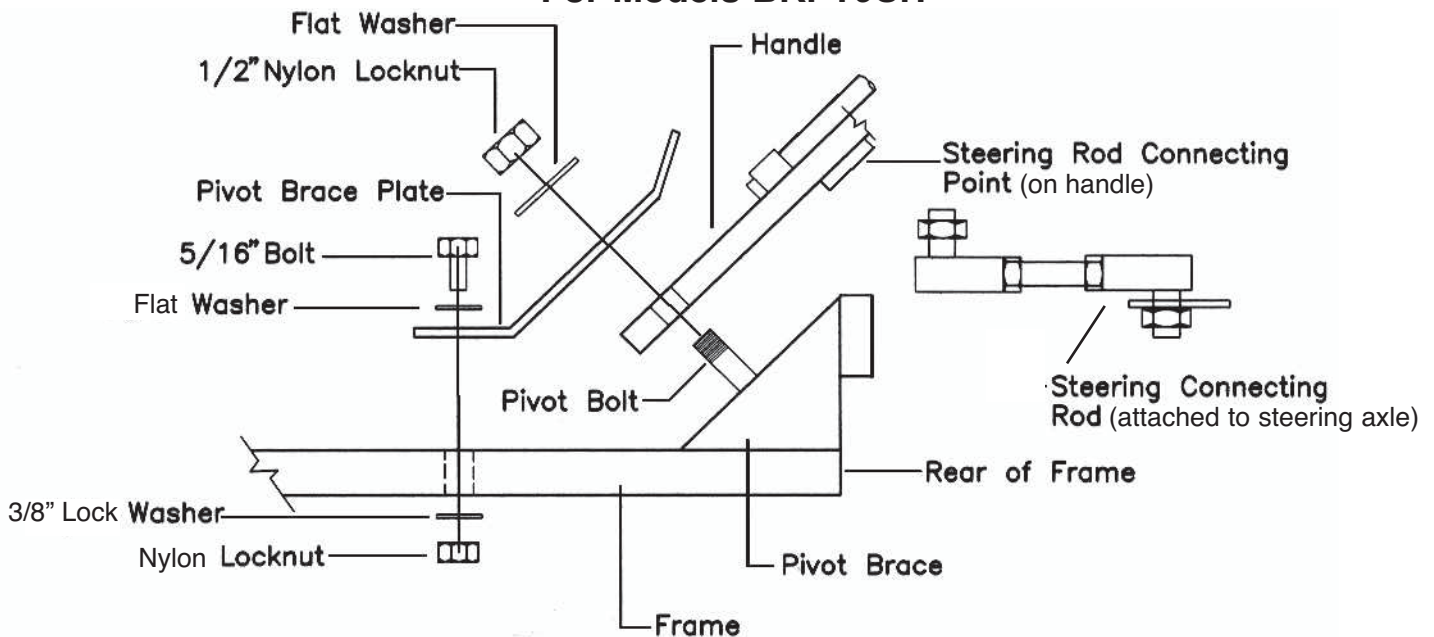

NOTE: Assembly only requires handle installation and connection of clutch cable.

1. Remove the 3 wing nuts from the belt guard and remove the cover.
2. Remove the rubber protective cover from the pivot bolt.
3. Place the handle down over the pivot bolt until it sits flat on the pivot brace.
4. Place the pivot brace plate over the pivot bolt on top of the handle.
5. Align the handle with the machine and secure the pivot brace plate to the frame using the 5/16" X 1" bolt, washer and locknut.
6. Lock the steering lock rod in the pivot brace plate and install the flat washer and the 1/2" nylon lock nut on the pivot bolt.
7. Tighten the 1/2 nylon lock nut down completely and then loosen 1/4 turn.
8. Align the rear wheels and attach the steering connecting rod (already attached to the steering axle) to the handle. The tie rod end must be under the connecting point on the handle. If necessary, adjust the length of the steering connecting rod to insure proper tracking of the rear wheels. Unlock the steering lock rod and turn the handle. If the lock rod doesn't release and prevents the handle from turning, you may need to adjust the lock rod catch on the upper part of the handle.
9. Pass the cable clevis through the sheave guard (mounted on the pivot brace plate) and attach to the idler arm with a clevis pin and cotter key. Install the cable sheave in the sheave guard with a sheave pin (clevis pin) through the upper holes (on top of the cable) and place another sheave pin through the lower holes under the cable. Secure both sheave (clevis) pins with cotter keys. Attach the clutch cable spring to the clutch lever. Adjust the tension on the control cable by shortening or lengthening the turnbuckle attached to clutch spring. When properly adjusted, the spring should stretch about 3/4" to 1" when the clutch lever is closed. Be sure to tighten the jam nut on the turnbuckle once the proper tension is set.
10. Replace the belt guard cover and secure it with the 3 wing nuts.
11. To install the rotor blade, remove the outside nut from the spindle (the inside nut is fixed to the spindle). When looking under the hood, the rotor turns counter clockwise. Therefore, place the rotor on the spindle with the points pointed up on the end of the rotor nearest the handle. Replace the nut, securing the rotor on the spindle. This nut does not need to be put on extremely tight. Tighten to about 100 foot pounds of torque or hand tighten with a 14" pipe wrench. CAUTION!! If using an impact wrench, do not over tighten because it may be very difficult to loosen the nut to change rotors.

NOTE: GREASE SHOULD NOT BE USED ON ANY STEERING PARTS. WE FEEL THERE WILL BE MINIMUM WEAR BECAUSE THE MOVEMENT OF THE PARTS WILL BE LIMITED. GREASE WILL ATTRACT DIRT WHICH ONLY INCREASES WEAR.



CAUTION: The engine is shipped without oil so oil must be added before starting engine.

BRPT9SH Parts Drawings

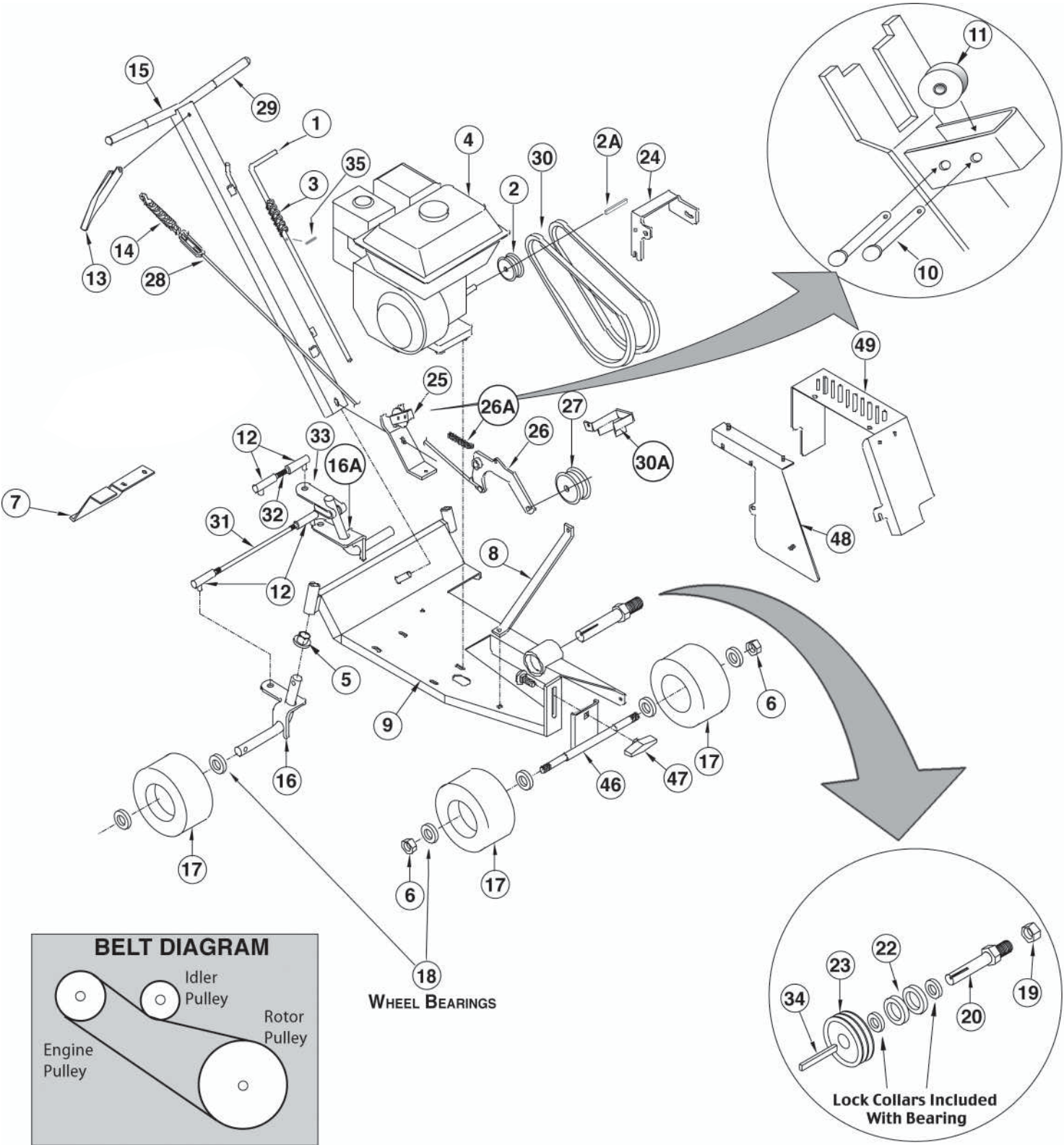

BELT DIAGRAM

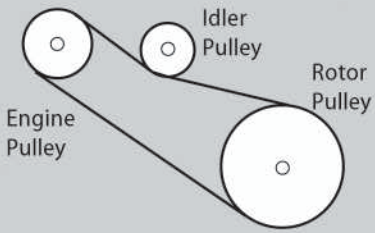

WHEEL BEARINGS

Lock Collars Included With Bearing

BRPT9SH Clay Hood Parts Drawings

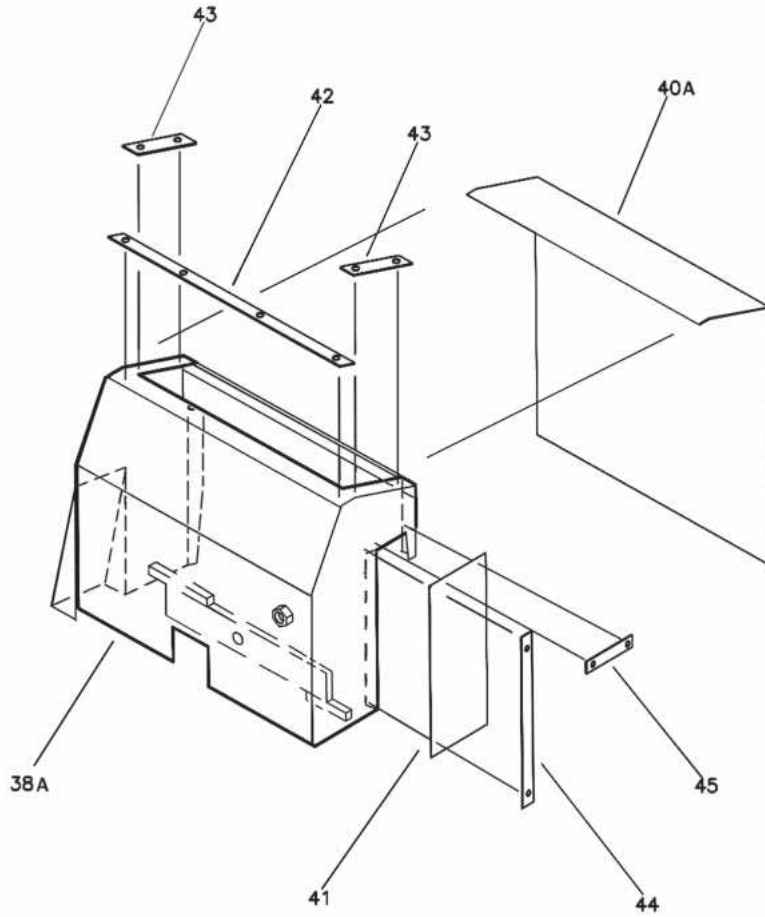

BRPT9SH
HOOD ASSEMBLY

37A

BRPT9SH

Parts List

REF.NO.	PART NO.	DISCRIPTION	NO. REQD.
1	780-08	STEERING LOCK ROD	1 EA.
2	780-09	PULLEY, ENGINE, 1" BORE	1 EA.
2A	12-19	Key 1/4" x 1/2"	1 EA.
3	780-32	SPRING, LOCK HANDLE RETURN	1 EA.
4	ENGINE	HONDA® ENGINE	1 EA.
5	780-04	BUSHINGS, AXLE SPINDLE, NYLON	4 EA.
6	701-06A	LOCK NUT, 5/8"	2 EA.
7	991-11	DIRT DEFLECTOR (F-991H)	1 EA.
8	702-53	UPPER HOOD BRACE	1 EA.
9	BR991-01	FRAME ASSEMBLY (W/PULLEY, SPINDLE & BEARINGS)	1 EA.
10	12-09	SHEAVE PIN W/COTTER KEY	2 EA.
11	12-08	CABLE SHEAVE	1 EA.
12	780-03	BALL JOINTS	4 EA.
13	702-12	CLUTCH LEVER	1 EA.
14	701-24A	CLUTCH SPRING	1 EA.
15	991-02	HANDLE	1 EA.
16	780-01	AXLE, SPINDLE (RIGHT)	1 EA.
16A	780-02	AXLE, SPINDLE (LEFT)	1 EA.
17	702-50C	WHEEL, PNUEMATIC 5/8" BEARING	4 EA.
18	702-27B	WHEEL BEARING, 5/8"	8 EA.
19	12-14	NUT, ROTOR, 1" NC. GRADE 5	1 EA.
20	702-57	SPINDLE, ROTOR, 1"	1 EA.
22	12-16	SPINDLE BEARING, ECCENTRIC, W/LOCK COLLAR	2 EA.
23	702-59-2	ROTOR PULLEY, DOUBLE BELT	1 EA.
24	991-03	BRACE, ENGINE TO HOOD	1 EA.
25	991-04	BRACE PLATE, HANDLE PIVOT	1 EA.
26	991-05	IDLER ARM	1 EA.
26A	991-06	SPRING, IDLER ARM RETURN	1 EA.
27	12-22-2A	DOUBLE IDLER PULLEY	1 EA.
28	991-07	CLUTCH CABLE W/ CLEVIS & TURNBUCKLE	1 EA.
29	701-25	HANDLE GRIP	2 EA.
30	780-30	BELT	2 EA.
30A	991-08	BELT STOP	1 EA.
31	780-06	STEERING TIE ROD	1 EA.
32	991-09	STEERING CONNECTING ROD STUD	1 EA.
33	780-05	STEERING CONTROL ARM	1 EA.
34	12-19	KEY, ROTOR PULLEY, & ENGINE PULLEY, 1/4" X 1-1/2"	2 EA.
35	780-31	PIN, ROLL, STEERING LOCK	1 EA.
*37A	BR990-02	CLAY HOOD ASSEMBLY (COMPLETE)	1 EA.
*38A	BR990-03	CLAY HOOD ONLY	1 EA.
*40A	990-04	RUBBER DRAPE	1 EA.
41	702-74	RUBBER FLAP	1 EA.
42	702-75	UPPER DRAPE STRAP	1 EA.
43	702-76	END DRAPE STRAP	2 EA.
44	702-77	VERTICAL FLAP STRAP	1 EA.
45	702-78	HORIZONTAL FLAP STRAP	1 EA.
46	703-10	HEIGHT ADJUSTER, FRONT WHEELS	1 EA.
47	991-10	HEIGHT ADJUSTER KNOB W/CARRIAGE BOLT, (1/2" X 1-1/4")	1 EA.
48	991-12	BELT GUARD MOUNTING BRACKET	1 EA.
49	991-13	BELT GUARD COVER	1 EA.
	702-122	WRENCH, ROTOR NUT W/ HANDLE	1 EA.

ROTOR COMPATIBILITY LIST

"X" INDICATES ROTOR WILL FIT ON BRPT9SH TRENCHER

CLAY ROTORS			TRENCHER BRPT9SH
Part #	Depth X Width		
702-81	3" X 1"	2 POINTS	X
702-82	4" X 1"	2 POINTS	X
702-82A	5" X 1"	2 POINTS	X
702-87	7" X 1"	2 POINTS	X
702-130	3" X 2"	3 POINTS	X
702-131	4" X 2"	3 POINTS	X
702-132	5" X 2"	3 POINTS	X
702-133	7" X 2"	3 POINTS	X
702-134	7" X 1 ^{3/8"}	3 POINTS	X
702-135	5" X 1 ^{3/8"}	2 POINTS	X
702-89	4" BEDMASTER	ROTOR	X
702-93	3" BEDMASTER	ROTOR	X
702-93R	REDEFINING	ROTOR	X
702-100	STUMPMASTER	ROTOR	X
702-106	5" BEDMASTER	ROTOR	X
702-112	4 ^{1/2"} X 4 ^{1/2"}	RAIN DRAIN	X
702-113	2" X 9"	CURBING ROTOR	X
ROCK ROTORS			
702-58	5" X 1 ^{1/2"}	W/O POINTS	X
702-85	4" X 1 ^{1/2"}	W/O POINTS	X
12-37	7" X 1 ^{1/2"}	W/O POINTS	X
ROOT PRUNER ROTORS			
702-90	4" X 1/2"	2 PT. @ EA. END	X
702-92	3" X 1 ^{1/2"}	2 PT. @ EA. END	X
12-41	7" X 1 ^{1/2"}	2 PT. @ EA. END	X
12-41A	5" X 1 ^{1/2"}	2 PT. @ EA. END	X

Your Brave Pro Trencher is a versatile powerhouse. Simply change rotors for unlimited flexibility.

IMPORTANT:

Rotor Installation

Turn rotor nut to the left to remove.

When looking inside the hood, (from the "flap" side), the rotor rotates in a counter clockwise motion.

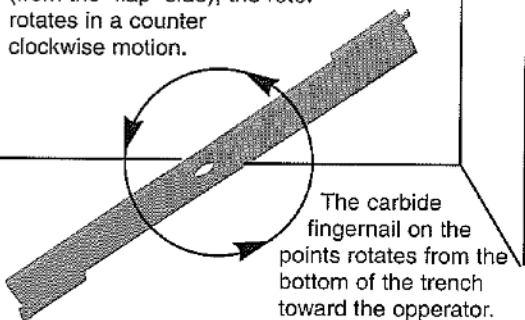

The carbide fingernail on the points rotates from the bottom of the trench toward the operator.

How To Determine The "Trench Depth" of A Rotor.

It requires 3.5" from the center of the rotor hole simply to reach the ground.

Measure from the center of the rotor hole to the end of the rotor point. Subtract 3.5" and this gives the depth the rotor will dig.

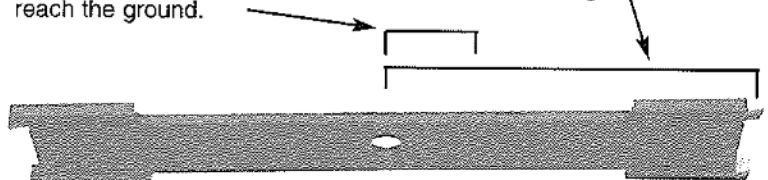

BRAVE

20195 S. Diamond Lake Rd, Ste 100
Rogers, MN 55374
1-800-350-8739