



TEST REPORT

Test activity on lifting device for roof carriers

Customer (*Richiedente*):

- Firm: HPG AS
- Mr.: Helge Åsteson Dimmen
- Address: Leirfossvegen 5D, N-7037 Trondheim

Test Request Form no.:
Modulo Richiesta Prova n.:

MES1295065A00

Test Report sent to:
Rapporto inviato a:

Mr. Helge Åsteson Dimmen

Name and Signature of the test engineer:
Nome e Firma esecutore prova:

Maurizio Leone

Name and Signature of the Technical reviewer:
Nome e Firma del Revisore tecnico:

Gianpaolo Mensa

Date of test samples receipt:
Data ricevimento campioni:

2019-05-13

Date of test execution:
Data esecuzione prove:

From 2019-05-13 to 2019-05-14

Site of test execution (if different from the address in the footer):
Località esecuzione prove (se diversa dal piè pagina):

Leirfossvegen 5D, N-7037 Trondheim

Witness to the test:
Presenti alle prove:

Mr. Paal Bierman Joergensen

Mr. André Klatt
Mr. Jens Harald Seiirtun
Mr. Teo R. Tandberg

The test results contained in this Test report relate to the tested samples only.

I risultati del presente rapporto di prova si riferiscono esclusivamente al campione sottoposto a prova.

The integral reproduction of the present Test report is allowed; the partial reproduction must be authorized in writing by the Lab.
E' ammessa la riproduzione integrale del presente Rapporto di prova da parte del Richiedente; la riproduzione parziale dev'essere autorizzata per iscritto dal Laboratorio.

Form: ITA_F_09.01E (Rev.21 – August 26, 2016)

Test report n.: MES1295065A00
Revision: 0
Document name: MES1295065A00.doc

Project handler:
Maurizio Leone
Issue date: 2019-05-21

Phone: +39 0125 636911
Fax: +39 0125 636999
Maurizio.leone@tuv.it

TÜV Italia SRL
Divisione PS-Laboratori
Via Montalenghe 8
I-10010 Scarmagno (TO)



| | |
|---|--|
| 1 TEST SETUP <i>SETUP DI PROVA</i> | |
| 1.1 SAMPLE IDENTIFICATION <i>IDENTIFICAZIONE CAMPIONE</i> | |
| 1.1.1 Product/material subjected to test: <i>Prodotto/materiale sottoposto a prova:</i> | Dropracks XL, Dropracks Sport |
| 1.1.2 Description: <i>Descrizione:</i> | Lifting system for carrying load on car roofs |
| 1.1.3 Level (Series product, prototype, etc.): <i>Livello (Prodotto di serie, prototipo, ecc.):</i> | Series product |
| 1.1.4 Part number: <i>Codice prodotto:</i> | -- |
| 1.1.5 Serial number: <i>N° Matricola:</i> | -- |
| 1.1.6 Sample identification code: <i>Codice identificativo del campione:</i> | -- |
| 1.2 AUXILIARY DEVICES <i>DISPOSITIVI AUSILIARI</i> | -- |
| 1.3 TEST CONFIGURATION <i>CONFIGURAZIONE DI PROVA</i> | According to DIN 75302:91 and to client in-house test protocol |
| 1.4 DIAGNOSTIC SYSTEM <i>SISTEMA DIAGNOSTICO</i> | According to DIN 75302:91 and to client in-house test protocol |

Form: ITA_F_09.01E (Rev.21 – August 26, 2016)

Test report n.: MES1295065A00
Revision: 0
Document name: MES1295065A00.doc

Project handler:
Maurizio Leone
Issue date: 2019-05-21

Phone: +39 0125 636911
Fax: +39 0125 636999
Maurizio.leone@tuv.it

TÜV Italia SRL
Divisione PS-Laboratori
Via Montalenghe 8
I-10010 Scarmagno (TO)

2 TEST LIST

ELENCO DELLE PROVE

| Test Description | Reference document | Standardized | Differences |
|--|-------------------------------|--------------|-------------|
| 2.1 Load shifting safety | § 3.6.1 of DIN 75302:91 | Yes | No |
| 2.2 Resistance to jolting | § 3.6.2 of DIN 75302:91 | Yes | No |
| 2.3 Tensile load in direction of drive | § 3.7.1 of DIN 75302:91 | Yes | No |
| 2.4 Tensile load in direction of drive 20° | § 3.7.2 of DIN 75302:91 | Yes | No |
| 2.5 Lifting forces | § 3.7.3 of DIN 75302:91 | Yes | No |
| 2.6 Simulation of cross wind | § 3.7.4 of DIN 75302:91 | Yes | No |
| 2.7 Dynamic use in horizontal terrain | Client in-house test protocol | No | No |
| 2.8 Dynamic use in the hillside | Client in-house test protocol | No | No |
| 2.9 Simulation of load scenario in the hillside | Client in-house test protocol | No | No |
| 2.10 Simulation of rough sideways loading in the lowered position | Client in-house test protocol | No | No |
| 2.11 Simulation of user pulling on the handlebar | Client in-house test protocol | No | No |
| 2.12 Simulation of user pushing on the handlebar | Client in-house test protocol | No | No |
| 2.13 Simulation of an overloaded rack in the out position | Client in-house test protocol | No | No |
| 2.14 Simulation of an overloaded rack in the lowered position | Client in-house test protocol | No | No |

Form: ITA_F_09.01E (Rev.21 – August 26, 2016)

Test report n.: MES1295065A00
Revision: 0
Document name: MES1295065A00.doc

Project handler:
Maurizio Leone
Issue date: 2019-05-21

Phone: +39 0125 636911
Fax: +39 0125 636999
Maurizio.leone@tuv.it

TÜV Italia SRL
Divisione PS-Laboratori
Via Montalenghe 8
I-10010 Scarmagno (TO)



3 TEST EQUIPMENT USED APPARECCHIATURE UTILIZZATE

| Description | Manufacturer | Model | Serial no./ID | Used in test n.: |
|-------------|--------------|------------------------------------|---------------|--|
| Caliper | Mitutoyo | 500-181U | CLB_04 | 2.1, 2.2, 2.3, 2.4, 2.5, 2.6, 2.7, 2.8, 2.9, 2.10, 2.11, 2.12, 2.13, 2.14; |
| Chronometer | Han Hart | Magma Pro Model: 237.1952-00 | CRN_36 | 2.1, 2.2, 2.3, 2.4, 2.5, 2.6, 2.7, 2.8, 2.9, 2.10, 2.11, 2.12, 2.13, 2.14; |
| Meter | Mitutoyo | 216-382 | FLE_40 | 2.1, 2.2, 2.3, 2.4, 2.5, 2.6, 2.7, 2.8, 2.9, 2.10, 2.11, 2.12, 2.13, 2.14; |
| Load cell | Celmi | 336A-1T-C3 | CEL_181 | 2.1, 2.2, 2.3, 2.4, 2.5, 2.6, 2.7, 2.8, 2.9, 2.10, 2.11, 2.12, 2.13, 2.14; |
| | | | | |
| | | | | |

4 MEASUREMENT UNCERTAINTY INCERTEZZA DI MISURA

Measurement uncertainties was estimated as expanded uncertainty obtained multiplying the standard uncertainty by the coverage factor k corresponding to a confidence level of about 95%. Declared uncertainties are obtained with factor k=2 except if otherwise specified.

| Measurement | Expanded uncertainty | Found in test n.: |
|-------------|----------------------|--|
| Dimension | $\pm 0,06$ mm | 2.1, 2.2, 2.3, 2.4, 2.5, 2.6, 2.7, 2.8, 2.9, 2.10, 2.11, 2.12, 2.13, 2.14; |
| Force | $\pm 3,5$ % | 2.1, 2.2, 2.3, 2.4, 2.5, 2.6, 2.7, 2.8, 2.9, 2.10, 2.11, 2.12, 2.13, 2.14; |
| Time | $\pm 0,59$ s | 2.1, 2.2, 2.3, 2.4, 2.5, 2.6, 2.7, 2.8, 2.9, 2.10, 2.11, 2.12, 2.13, 2.14; |
| | | |
| | | |
| | | |

Form: ITA_F_09.01E (Rev.21 – August 26, 2016)

Test report n.: MES1295065A00
Revision: 0
Document name: MES1295065A00.doc

Project handler:
Maurizio Leone
Issue date: 2019-05-21

Phone: +39 0125 636911
Fax: +39 0125 636999
Maurizio.leone@tuv.it

TÜV Italia SRL
Divisione PS-Laboratori
Via Montalenghe 8
I-10010 Scarmagno (TO)



Italia

5 SAMPLING PLAN

PIANO DI CAMPIONAMENTO

Samples selected by the client

Form: ITA_F_09.01E (Rev.21 – August 26, 2016)

Test report n.: MES1295065A00
Revision: 0
Document name: MES1295065A00.doc

Project handler:
Maurizio Leone
Issue date: 2019-05-21

Phone: +39 0125 636911
Fax: +39 0125 636999
Maurizio.leone@tuv.it

TÜV Italia SRL
Divisione PS-Laboratori
Via Montalenghe 8
I-10010 Scarmagno (TO)



6 TEST AND/OR MEASUREMENT RESULTS

RISULTATI DELLE PROVE E/O MISURE

6.1 TEST NO.1

Load shifting safety

(DIN 75302:1991 section 3.6.1)

After three braking tests from a speed of 80 km/h there shall be

- a) no apparent permanent deformation,
- b) no brace shall slip more than 3 mm and
- c) no bolt connection shall exhibit a drop in tightening torque of more than 30 %.

6.1.1 TEST RESULTS

RISULTATI DI PROVA

The model met the requirement

6.2 TEST NO.2

Resistance to jolting

(DIN 75302:1991 clause 3.6.2)

- a) After driving on the "Belgian-Block-Route" with a speed of 25 km/h there shall be no apparent permanent deformation.
- b) no bolt connection shall exhibit a drop in tightening torque of more than 30 %.
- c) The corresponding load shall still be secured to the roof rack.

6.2.1 TEST RESULTS

RISULTATI DI PROVA

The model met the requirement

6.3 TEST NO.3

Tensile load in direction of drive

(DIN 75302:1991 clause 3.7.1)

The samples have to resist the forces according to table 2 of DIN 75302:1991 without any visible damage.

6.3.1 TEST RESULTS

RISULTATI DI PROVA

Load capacity = 100 kg

$F_L = 4034 \text{ N}$

The model met the requirement.

Form: ITA_F_09.01E (Rev.21 – August 26, 2016)

Test report n.: MES1295065A00
Revision: 0
Document name: MES1295065A00.doc

Project handler:
Maurizio Leone
Issue date: 2019-05-21

Phone: +39 0125 636911
Fax: +39 0125 636999
Maurizio.leone@tuv.it

TÜV Italia SRL
Divisione PS-Laboratori
Via Montalenghe 8
I-10010 Scarmagno (TO)



6.4 TEST NO.4

Tensile load in direction of drive 20°

(DIN 75302:1991 section 3.7.2)

The samples have to resist the forces according to table no. 2 of DIN 75302:1991 without any visible damage.

6.4.1 TEST RESULTS

RISULTATI DI PROVA

Load capacity = 100 kg

$F_{LQ} = 4029 \text{ N}$

The model met the requirement.

6.5 TEST NO.5

Lifting forces

(DIN 75302:1991 clause 3.7.3)

After the vertical tensile load no part of the sample may deform, that the function by regulations is not restricted.

6.5.1 TEST RESULTS

RISULTATI DI PROVA

$F_A = 3500 \text{ N}$

Application time = 10 minutes

The model met the requirement.

6.6 TEST NO.6

Simulation of cross wind

(DIN 75302:1991 section 3.7.4)

After testing, neither the load nor any part of the rack shall be deformed so that the intended function is impaired

6.6.1 TEST RESULTS

RISULTATI DI PROVA

$F_{LAT} = 600 \text{ N}$

Application time = 10 minutes

The model met the requirement.

Form: ITA_F_09.01E (Rev.21 – August 26, 2016)

Test report n.: MES1295065A00
Revision: 0
Document name: MES1295065A00.doc

Project handler:
Maurizio Leone
Issue date: 2019-05-21

Phone: +39 0125 636911
Fax: +39 0125 636999
Maurizio.leone@tuv.it

TÜV Italia SRL
Divisione PS-Laboratori
Via Montalenghe 8
I-10010 Scarmagno (TO)



6.7 TEST NO.7 Dynamic use in horizontal terrain

Mount the test box in the middle of the loading surface to evenly distribute the load on the surface. Load the rack with 112.5kg (including the weight of the test box itself). Start from lowered position, crank the rack up, push it onto the roof to locked position, before lowering it all the way down again. Perform this lifting-lowering-cycle three times.

Rack position: Rack in motion

Direction of force: Load (towards ground) = F_N

Load = 112.5kg

Durability = x 3

Tilt = Horizontal

Requirement

No apparent permanent deformation shall be discernible

Result:

The model met the requirement

6.8 TEST NO.8 Dynamic use in the hillside

The rack shall have a sideways tilt of 10° (simulating car facing uphill). Mount the test box in the middle of the loading surface to evenly distribute the load on the surface. Load the rack with 112.5kg (including the weight of the test box itself). Start from lowered position, crank the rack up, push it onto the roof to locked position, before lowering it all the way down again. Perform this lifting-lowering-cycle three times.

Rack position: Rack in motion

Direction of force: Load (towards ground) = $F_{N\alpha}$

Load = 112.5kg

Durability = x 3

Tilt = 10° sideways

Requirement

No apparent permanent deformation shall be discernible

Result:

The model met the requirement

Form: ITA_F_09.01E (Rev.21 – August 26, 2016)

Test report n.: MES1295065A00

Revision: 0

Document name: MES1295065A00.doc

Project handler:

Maurizio Leone

Issue date: 2019-05-21

Phone: +39 0125 636911

Fax: +39 0125 636999

Maurizio.leone@tuv.it

TÜV Italia SRL

Divisione PS-Laboratori

Via Montalenghe 8

I-10010 Scarmagno (TO)



6.9 TEST NO: 9 Simulation of load scenario in the hillside

The rack shall have a sideways tilt of 10° (simulating car facing uphill). Mount the test box in the middle of the loading surface to evenly distribute the load on the surface. Load the rack with 112.5kg (including the weight of the test box itself). Keep the rack static in the lowered position for 10 minutes.

Rack position: Lowered position

Direction of force: Load (towards ground) = F_{N0}

Load = 112.5kg

Durability = 10 min

Tilt = 10° sideways

Requirement

No breaking shall appear

Result:

The model met the requirement

6.10 TEST NO:10 Simulation of rough sideways loading in the lowered position

Empty the test box. Position the rack in the lowered position. Attach a force on the middle of the side of the test box facing either forward or backwards along the car. Make a pull horizontally away from the rack along the longitudinal axis of the car with a magnitude of 900N for one minute.

Rack position: Lowered position

Direction of force: Direction of travel = F_{LL}

Force = 900N

Durability = 1 min

Tilt = Horizontal

Requirement

No breaking shall appear

Result:

The model met the requirement

Form: ITA_F_09.01E (Rev.21 – August 26, 2016)

Test report n.: MES1295065A00
Revision: 0
Document name: MES1295065A00.doc

Project handler:
Maurizio Leone
Issue date: 2019-05-21

Phone: +39 0125 636911
Fax: +39 0125 636999
Maurizio.leone@tuv.it

TÜV Italia SRL
Divisione PS-Laboratori
Via Montalenghe 8
I-10010 Scarmagno (TO)



6.11 TEST NO.11 Simulation of user pulling on the handlebar

Empty the test box, alternatively also remove the test box from the rack such that there is little to no load on the rack. Position the rack in the lowered position. Attach a force on the middle of the Handlebar and make a pull horizontally outwards away from the car (the force as a normal axis to the vertical side of the car) with a magnitude of 900N for one minute.

Rack position: Lowered position

Direction of force: Towards user = F_{POut}

Force = 900N

Durability = 1 min

Tilt = Horizontal

Requirement

No breaking shall appear

Result:

The model met the requirement

6.12 TEST NO.12 Simulation of user pushing on the handlebar

Empty the test box, alternatively also remove the test box from the rack such that there is little to no load on the rack. Position the rack in the lowered position. Attach a force on the middle of the Handlebar and make a pull horizontally inwards towards the car (the force as a normal axis to the vertical side of the car) with a magnitude of 900N for one minute.

Rack position: Lowered position

Direction of force: Towards car = F_{PIIn}

Force = 900N

Durability = 1 min

Tilt = Horizontal

Requirement

No breaking shall appear

Result:

The model met the requirement

Form: ITA_F_09.01E (Rev.21 – August 26, 2016)

Test report n.: MES1295065A00
Revision: 0
Document name: MES1295065A00.doc

Project handler:
Maurizio Leone
Issue date: 2019-05-21

Phone: +39 0125 636911
Fax: +39 0125 636999
Maurizio.leone@tuv.it

TÜV Italia SRL
Divisione PS-Laboratori
Via Montalenghe 8
I-10010 Scarmagno (TO)



6.13 TEST NO.13 Simulation of an overloaded rack in the out position

From locked position on top of the car; slide the rack out horizontally all the way until it stops, without using the crank. In this out position, attach a force of 2000N from the centre of the test box, pointing vertically down to the floor. Keep the force for 10 minutes.

Rack position: Out position

Direction of force: Load (towards ground) = F_N

Force = 2000N

Durability = 10 min

Tilt = Horizontal

Requirement

No breaking shall appear

Result:

The model met the requirement

6.14 TEST NO.14 Simulation of an overloaded rack in the lowered position

In the lowered position, attach a force of 2000N from the centre of the test box, pointing vertically down to the floor. Keep the force for 10 minutes.

Rack position: Lowered position

Direction of force: Load (towards ground) = F_N

Force = 2000N

Durability = 10 min

Tilt = Horizontal

Requirement

No breaking shall appear

Result:

The model met the requirement

Form: ITA_F_09.01E (Rev.21 – August 26, 2016)

Test report n.: MES1295065A00
Revision: 0
Document name: MES1295065A00.doc

Project handler:
Maurizio Leone
Issue date: 2019-05-21

Phone: +39 0125 636911
Fax: +39 0125 636999
Maurizio.leone@tuv.it

TÜV Italia SRL
Divisione PS-Laboratori
Via Montalenghe 8
I-10010 Scarmagno (TO)

7 REMARKS
NOTE

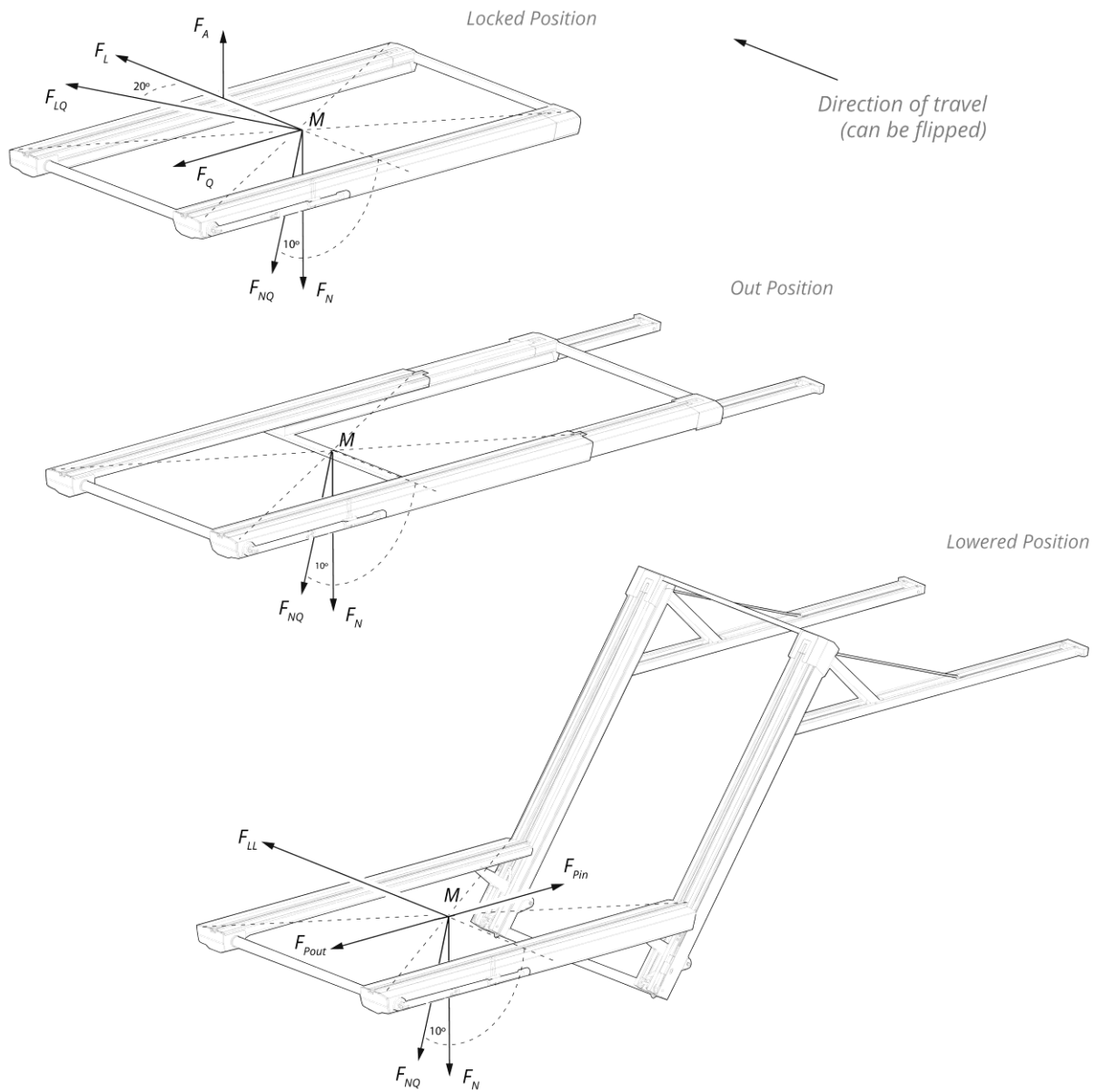

fig.1

Form: ITA_F_09.01E (Rev.21 – August 26, 2016)

Test report n.: MES1295065A00
Revision: 0
Document name: MES1295065A00.doc

Project handler:
Maurizio Leone
Issue date: 2019-05-21

Phone: +39 0125 636911
Fax: +39 0125 636999
Maurizio.leone@tuv.it

TÜV Italia SRL
Divisione PS-Laboratori
Via Montalenghe 8
I-10010 Scarmagno (TO)



Description of forces in fig. 1

| | |
|------------|--|
| F_N | See DIN 75302:91 |
| F_A | See DIN 75302:91 |
| F_Q | See DIN 75302:91 |
| F_L | See DIN 75302:91 |
| F_{LQ} | See DIN 75302:91 |
| F_{NQ} | Forces in the vertical plane, acting at 10° to the vertical axis of the vehicle through a mid-point M of the load surface |
| F_{LL} | Longitudinal force in N produced by the loading and unloading of equipment |
| F_{Pin} | Transverse force towards the car, at the handlebar, produced by the loading and unloading of equipment or pushing to lift the rack |
| F_{Pout} | Transverse force away from the car, at the handlebar, produced by loading and unloading of equipment or pulling to lower the rack |

Form: ITA_F_09.01E (Rev.21 – August 26, 2016)

Test report n.: MES1295065A00
Revision: 0
Document name: MES1295065A00.doc

Project handler:
Maurizio Leone
Issue date: 2019-05-21

Phone: +39 0125 636911
Fax: +39 0125 636999
Maurizio.leone@tuv.it

TÜV Italia SRL
Divisione PS-Laboratori
Via Montalenghe 8
I-10010 Scarmagno (TO)

8 APPENDIX

APPENDICE

8.1 PHOTO DOCUMENTATION

DOCUMENTAZIONE FOTOGRAFICA



Form: ITA_F_09.01E (Rev.21 – August 26, 2016)

Test report n.: MES1295065A00
Revision: 0
Document name: MES1295065A00.doc

Project handler:
Maurizio Leone
Issue date: 2019-05-21

Phone: +39 0125 636911
Fax: +39 0125 636999
Maurizio.leone@tuv.it

TÜV Italia SRL
Divisione PS-Laboratori
Via Montalenghe 8
I-10010 Scarmagno (TO)



Italia

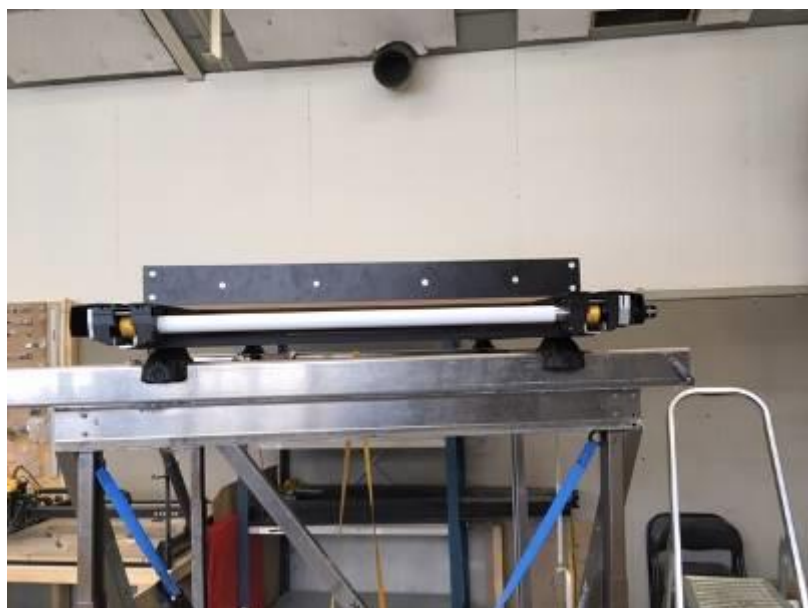

Form: ITA_F_09.01E (Rev.21 – August 26, 2016)

Test report n.: MES1295065A00
Revision: 0
Document name: MES1295065A00.doc

Project handler:
Maurizio Leone
Issue date: 2019-05-21

Phone: +39 0125 636911
Fax: +39 0125 636999
Maurizio.leone@tuv.it



TÜV Italia SRL
Divisione PS-Laboratori
Via Montalenghe 8
I-10010 Scarmagno (TO)



Italia



8.2 ATTACHMENTS

ALLEGATI

None

Form: ITA_F_09.01E (Rev.21 – August 26, 2016)

Test report n.: MES1295065A00
Revision: 0
Document name: MES1295065A00.doc

Project handler:
Maurizio Leone
Issue date: 2019-05-21

Phone: +39 0125 636911
Fax: +39 0125 636999
Maurizio.leone@tuv.it

TUV[®]

TÜV Italia SRL
Divisione PS-Laboratori
Via Montalenghe 8
I-10010 Scarmagno (TO)



9 SUMMARY

SOMMARIO

The roof racks, Dropracks XL and Dropracks Sport, have been tested and comply with the standard DIN 75302:91 and internal tests.

Form: ITA_F_09.01E (Rev.21 – August 26, 2016)

Test report n.: MES1295065A00
Revision: 0
Document name: MES1295065A00.doc

Project handler:
Maurizio Leone
Issue date: 2019-05-21

Phone: +39 0125 636911
Fax: +39 0125 636999
Maurizio.leone@tuv.it

TÜV Italia SRL
Divisione PS-Laboratori
Via Montalenghe 8
I-10010 Scarmagno (TO)



| | | |
|----------|--|----------|
| 1 | TEST SETUP | 2 |
| 1.1 | SAMPLE IDENTIFICATION | 2 |
| 1.2 | AUXILIARY DEVICES | 2 |
| 1.3 | TEST CONFIGURATION | 2 |
| 1.4 | DIAGNOSTIC SYSTEM | 2 |
| 2 | TEST LIST | 3 |
| 2.1 | LOAD SHIFTING SAFETY | 3 |
| 2.2 | RESISTANCE TO JOLTING | 3 |
| 2.3 | TENSILE LOAD IN DIRECTION OF DRIVE | 3 |
| 2.4 | TENSILE LOAD IN DIRECTION OF DRIVE 20° | 3 |
| 2.5 | LIFTING FORCES | 3 |
| 2.6 | SIMULATION OF CROSS WIND | 3 |
| 2.7 | DYNAMIC USE IN HORIZONTAL TERRAIN | 3 |
| 2.8 | DYNAMIC USE IN THE HILLSIDE | 3 |
| 2.9 | SIMULATION OF LOAD SCENARIO IN THE HILLSIDE | 3 |
| 2.10 | SIMULATION OF ROUGH SIDEWAYS LOADING IN THE LOWERED POSITION | 3 |
| 2.11 | SIMULATION OF USER PULLING ON THE HANDLEBAR | 3 |
| 2.12 | SIMULATION OF USER PUSHING ON THE HANDLEBAR | 3 |
| 2.13 | SIMULATION OF AN OVERLOADED RACK IN THE OUT POSITION | 3 |
| 2.14 | SIMULATION OF AN OVERLOADED RACK IN THE LOWERED POSITION | 3 |
| 3 | TEST EQUIPMENT USED | 4 |
| 4 | MEASUREMENT UNCERTAINTY | 4 |
| 5 | SAMPLING PLAN | 5 |
| 6 | TEST AND/OR MEASUREMENT RESULTS | 6 |
| 6.1 | TEST NO.1 | 6 |
| 6.2 | TEST NO.2 | 6 |
| 6.3 | TEST NO.3 | 6 |
| 6.4 | TEST NO.4 | 7 |
| 6.5 | TEST NO.5 | 7 |
| 6.6 | TEST NO.6 | 7 |
| 6.7 | TEST NO.7 | 8 |
| | DYNAMIC USE IN HORIZONTAL TERRAIN | 8 |
| 6.8 | TEST NO.8 | 8 |
| | DYNAMIC USE IN THE HILLSIDE | 8 |
| 6.9 | TEST NO: 9 | 9 |
| | SIMULATION OF LOAD SCENARIO IN THE HILLSIDE | 9 |

Form: ITA_F_09.01E (Rev.21 – August 26, 2016)

Test report n.: MES1295065A00
Revision: 0
Document name: MES1295065A00.doc

Project handler:
Maurizio Leone
Issue date: 2019-05-21

Phone: +39 0125 636911
Fax: +39 0125 636999
Maurizio.leone@tuv.it

TÜV Italia SRL
Divisione PS-Laboratori
Via Montalenghe 8
I-10010 Scarmagno (TO)



| | | |
|----------|---|-----------|
| 6.10 | TEST NO:10 | 9 |
| 6.11 | TEST NO.11 | 10 |
| | SIMULATION OF USER PULLING ON THE HANDLEBAR | 10 |
| 6.12 | TEST NO.12 | 10 |
| 6.13 | TEST NO.13 | 11 |
| 6.14 | TEST NO.14 | 11 |
| 7 | REMARKS | 12 |
| 8 | APPENDIX | 14 |
| 8.1 | PHOTO DOCUMENTATION | 14 |
| 8.2 | ATTACHMENTS | 16 |
| 9 | SUMMARY | 17 |

Form: ITA_F_09.01E (Rev.21 – August 26, 2016)

Test report n.: MES1295065A00
Revision: 0
Document name: MES1295065A00.doc

Project handler:
Maurizio Leone
Issue date: 2019-05-21

Phone: +39 0125 636911
Fax: +39 0125 636999
Maurizio.leone@tuv.it

TÜV Italia SRL
Divisione PS-Laboratori
Via Montalenghe 8
I-10010 Scarmagno (TO)