

Solid-State Overload Relays

The new RW_E Solid State Overload relays are developed with cutting edge technology according to the most demanding standards worldwide. With its wide current/AMP setting; the RW_E OL Relay can be used for protection of electric motors of different power ratings. The benefit is versatility and flexibility for manufacturers due to the possibility of standardization of control panels. This Solid State Overload Relay can be directly mounted on WEG Contactors (CWM and CWB lines) providing very reliable and flexible motor starter units. The RW_E counts on two independent and highly reliable built in auxiliary contacts that assure the motor is switched off when a failure occurs.

Standard Features:

- 3-pole solid state overload relays with adjustable trip class: 10, 20 and 30
- Self-powered
- Wide adjustment range (5:1)
- Thermal memory
- Phase loss protection (less than 5 seconds)
- Phase unbalance protection (>40% between phases)
- Temperature compensated (-20 °C up to +60 °C)
- Manual or automatic reset modes
- Direct mounting on CWB9...38 and CWM9...105 contactors
- Separate mounting is possible with accessories
1NO + 1NC built in auxiliary contacts



UL File No. E189202

Solid-State Overload Relay Catalog Number Sequence

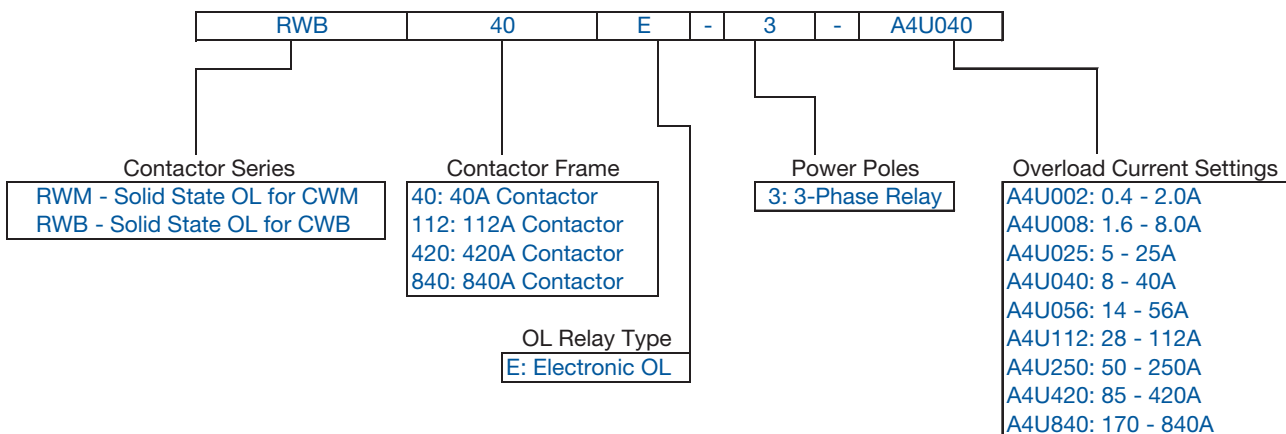

Chart intended as reference only and not to create part numbers.



RW-E Series

Suitable for Great Variety of Applications

The solid-state overload relays RW_E are suitable to protect motors in a wide range of industrial applications including those where long starting time is required. This way, motors on low, medium or heavy duty applications can be properly protected just by selecting the proper trip class (10, 20 or 30 according to IEC 60947-4-1) in the DIP-switches.

Additionally, the microprocessed electronic circuits of RW_E are temperature compensated according to IEC 60947-4-1, which means that throughout the temperature range of -20 °C up to +60 °C, the tripping point is not affected and it performs consistently without undesirable tripping.

The RW_E also features thermal memory which assures that the heating and cooling effects of motors are modeled and proper protection is guaranteed even after downtime periods.

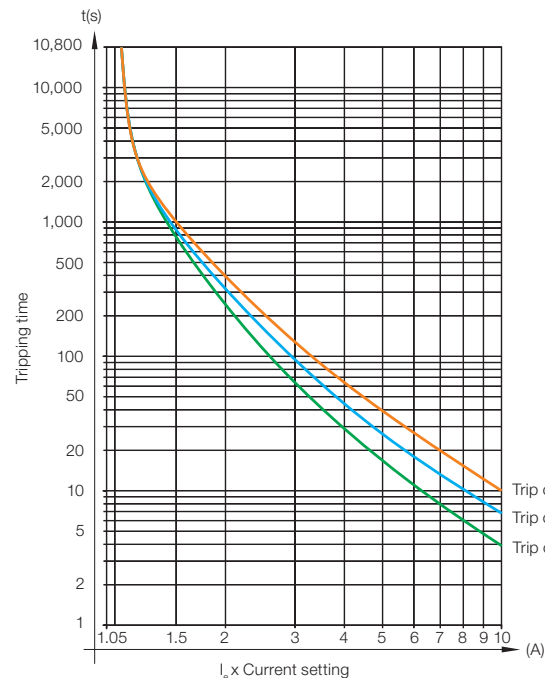

Trip class	Multiples of current setting			
	1.05 x I _r	1.2 x I _r	1.5 x I _r	7.2 x I _r
10	-	Tp <2h	Tp <4min	4 <Tp ≤10s
20	-	Tp <2h	Tp <8min	6 <Tp ≤20s
30	-	Tp <2h	Tp <12min	9 <Tp ≤30s

IEC 60947-4-1

Trip class 30
Trip class 20
Trip class 10

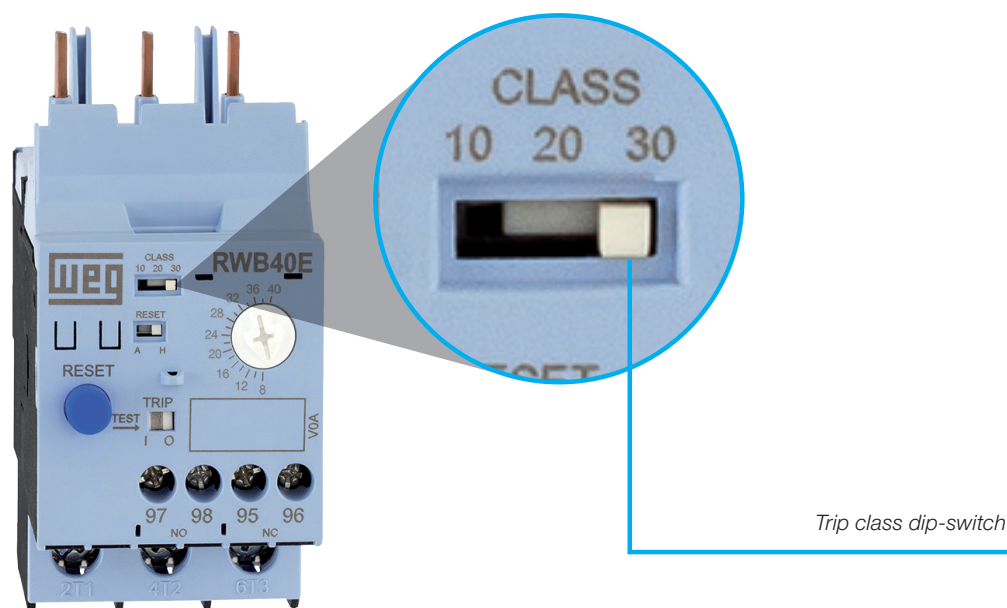

Trip class dip-switch

RW_E Solid-State Overload Relays from 0.4 up to 840 A

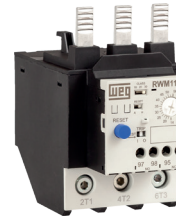

For direct mounting on contactors	Current range A	Diagram	Max fuse (gL/gG) A	Catalog Number	Weight kg	List Price	Multiplier
CWB9...38	0.4...2		16	RWB40E-3-A4U002	0.250	\$92	Z2
CWB9...38	1.6...8		32	RWB40E-3-A4U008			
CWB9...38	5...25		63	RWB40E-3-A4U025			
CWB9...38	8...40		125	RWB40E-3-A4U040	0.250	\$145	
CWM9...40	0.4...2		16	RWM40E-3-A4U002	0.250	\$92	
CWM9...40	1.6...8		32	RWM40E-3-A4U008			
CWM9...40	5...25		63	RWM40E-3-A4U025			
CWM9...40	8...40		125	RWM40E-3-A4U040	0.918	\$145	
CWM50...105	14...56		160	RWM112E-3-A4U056	0.918	\$225	
CWM50...105	28...112		250	RWM112E-3-A4U112	0.918	\$240	

Note: Not to be used in single-phase applications.



For separate mounting or by connector links ¹⁾	Current range A	Diagram	Max fuse (gL/gG) A	Catalog Number	Weight kg	List Price	Multiplier
CWM112...500	50...250		500	RWM420E-3-A4U250	2,520	\$490	Z2
	85...420		710	RWM420E-3-A4U420		\$580	
CWM150...800	170...840		1,250	RWM840E-3-A4U840	4,150	\$1,300	

Note: Not to be used in single-phase applications.

Note: 1) RWM840E model allows two different types of connection to contactor:

a) By connecting the contactor cables to relay busbars;

b) By removing the relay busbars and using the Ø32 mm window for the passage of the contactor cables.

General Information

Circuit Protection

Disconnect Switches

Motor Protectors

Contactors

Overloads

Enclosed Starters

Relays

Pushbuttons and Pilot Lights

Terminal Blocks

Power Factor Correction



Appendix A

Appendix B

RW-E Series

Accessories

Mounting Kit

Image	For use with relays	Description	Catalog Number	Weight kg	List Price	Multiplier
	RWM40E	Enables the overload relay to be mounted directly to a panel via screws or 35 mm DIN rail	BF27D	0.050	\$14	Z2
	RWB40E		BF27-2D			
	RWM112E		BF112	0.230	\$35	

Connector Links for Direct Mounting of Overload Relay on Contactor

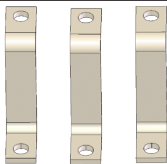
Image	For use with relays	For use with contactors	Catalog Number	Weight kg	List Price	Multiplier
	RWM112E	CWM112/150	GA117D	0.135	\$41	Z2
	RWM420E	CWM150	GA317-1D	0.250	\$68	
		CWM180	GA317-2D	0.270	\$70	
		CWM250/300	GA317-3D	0.630	\$118	
		CWM400	GA317-10D	0.500	\$118	

Phase Barriers

Image	For use with relays	Description	Catalog Number	Weight kg	List Price	Multiplier
	RWM420E	Contains 1 plastic insulator and fixing screws to be used where the overload relay power terminals external dimension exceed the busbar external dimension	IBRW317	0.044	\$4	Z2

Reset Pushbutton with Shaft

Image	For use with relays	Description	Catalog Number	Weight kg	List Price	Multiplier
	RW_E	Blue Flush pushbutton - Engraved Reset - with shaft. Length: max. 250 mm and min. 22.5 mm	CSW-BHF437	0.032	\$12	Z2

Technical Data

General Data

Product model			RWM40E / RWB40E	RWM112E	RWM420E	RWM840E
Standards			IEC 60947-4-1, IEC 60947-5-1, IEC 60947-1, UL 60947-1, UL 60947-4-1A and UL 508			
Rated insulation voltage U_i (pollution degree 3)	IEC 60947-4-1	(V)	690		100	
	UL, CSA	(V)	600			
Rated impulse withstand voltage U_{imp} (IEC 60947-1)		(kV)	6		8	
Rated operational frequency (sinusoidal networks)		(Hz)	50/60			
Suitable for use	Three phase loads		Yes			
	Single phase / two phase loads		No			
	DC current loads		No			
Trip class (IEC 60947-4-1)			10, 20 or 30 - selectable			
Additional featured protections	Phase loss		Yes / less than <5s			
	Phase unbalance		Yes / >40%			
Reset	Manual / minimum downtime for reset		Yes / instantaneous			
	Automatic / minimum downtime for reset		Yes / $\geq 90s$			
Maximum operation per hour		(ops./h)	30			
Protection degree (IEC 60529)	Main contacts		IP10		IP00	
	Auxiliary contacts		IP20			
Mounting			1)		2)	
Mechanical shock resistance - 1/2 sinusoid			15 g / 11ms			
Vibration resistance (IEC 60068-2-6)			6 g / 30...300 Hz			
Ambient temperature	Transport and storage		-50 °C...+80 °C			
	Operating		-20 °C...+60 °C			
	Temperature compensation		-20 °C...+60 °C			
Altitude			2,000 m			

Notes: 1) Direct mounting on contactor or directly on the panel via screws or 35 mm DIN rail when using the mounting kit accessory (BF27D and BF112)
 2) Direct mounting on contactor when using the Connector Link GA117 / GA317 accessory or directly on the panel via screws.

Main Contacts

Product model			RWM40E / RWB40E	RWM112E	RWM420E	RWM840E
Rated operational voltage U_e	IEC 60947-4-1	(V)	690		100	
	UL, CSA	(V)	600			
Current setting / max fuse (gL/gG)		(A)	0.4...2 / 16 1.6...8 / 32 5...25 / 63 8...40 / 125	14...56 / 160 28...112 / 250	50...250 / 500 85...420 / 710	170...840 / 1,250
Setting current / average power dissipation per pole		(W)	0.4...2 / 0.07 1.6...8 / 0.06 5...25 / 0.38 8...40 / 1.5	14...56 / 2 28...112 / 2.6	50...250 / 12 85...420 / 12	170...840 / 14.5

Notes: 1) Direct mounting on contactor or directly on the panel via screws or 35 mm DIN rail when using the mounting kit accessory (BF27D and BF112);
 2) Direct mounting on contactor when using the Connector Link GA117 / GA317 accessory or directly on the panel via screws.

General Information

Circuit Protection

Disconnect Switches

Motor Protectors

Contactors

Overloads

Enclosed Starters

Relays

Pushbuttons and Pilot Lights

Terminal Blocks

Power Factor Correction

Appendix A

Appendix B

Overloads

RW-E Series

Technical Data

Auxiliary Contacts

Product model			RWM40...840E / RWB40E
Rated insulation voltage Ui (pollution degree 3)	IEC 60947-4-1	(V)	250
	UL, CSA	(V)	600
Rated impulse withstand voltage Uimp (IEC 60947-1)		(kV)	4
Rated operational voltage Ue	IEC 60947-4-1	(V)	250
	UL, CSA	(V)	600
Rated thermal current Ith ≤ 60 °C)		(A)	5
Rated operational current Ie			
AC-14/AC-15 (IEC 60947-5-1)	24 V	(A)	3
	120 V	(A)	3
	250 V	(A)	1.5
DC-13 (IEC 60947-5-1)	24 V	(A)	2
	60 V	(A)	0.4
	110 V	(A)	0.22
	125 V	(A)	0.22
	250 V	(A)	0.1
NEMA control circuit ratings	UL, CSA		C300 / R300
Short-circuit protection with fuse		(A)	6
Minimum voltage / admissible current (IEC 60947-5-4)			12 V / 10 mA

Terminal Capacity and Tightening Torque - Main Contacts

Product model		BF27D	RWM40E / RWB40E	RW112E	BF112
Type of screw		M4 Flat / Phillips #2	M3.5 Flat / Phillips #2	M10 Allen #4	M10 Allen #4
Cable size					
Flexible cable	(mm ²)	1.5...10	-	-	-
Cable with terminal / rigid cable	(mm ²)	1.5...6	-	-	-
AWG wire		16...10	-	-	-
Tightening torque	(Nm)	2.3	-	-	-
Flexible cable	(mm ²)	-	1...10	2.5...35	2.5...35
Cable with terminal / rigid cable	(mm ²)	-	1...10	2.5...35	2.5...35
AWG wire		-	16...8	14...2	14...2
Tightening torque	(Nm)	-	1.7	6	6
Product model		RWM420E		RWM840E	
Type of screw		M10 Hexagon Head		M12 Hexagon Head	
Cable with terminal	(mm ²)	2 x (25...150)		2 x (60 x 10)	
Busbar (A x B x C)	(mm)	25 x 18.5 x 12.5		31.7 x 28.3 x 15	
Tightening torque	(Nm)	26		26	

Terminal Capacity and Tightening Torque - Auxiliary Contacts

Product model		RWM40...840E / RWB40E
Type of screw		Flat / Phillips #1
Cable size		
Cable with or without terminal	(mm ²)	1 x 1...2.5
AWG wire		16...12
Tightening torque	(Nm)	0.8

Technical Data

Motor Protection - Alternating Current

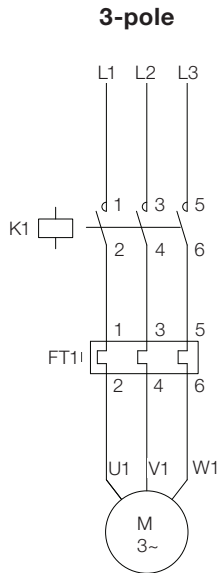

Typical Connection - Contactor + Overload Relay

Direct On Line Starter (1 Direction of Rotation)

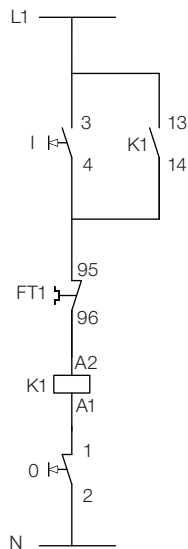

Direct On Line Starter (2 Directions of Rotation)

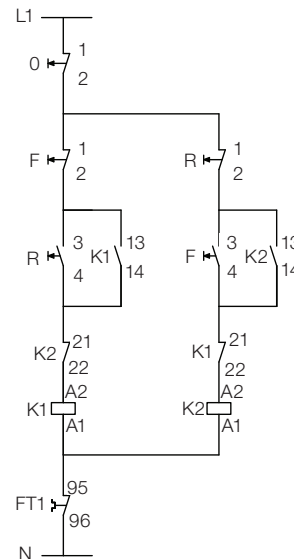

General Information

Circuit Protection

Disconnect Switches

Motor Protectors

Contactors

Overloads

Enclosed Starters

Relays

Pushbuttons and Pilot Lights

Terminal Blocks

Power Factor Correction

Appendix A

Appendix B

RW-E Series

General Information

Circuit Protection

Disconnect Switches

Motor Protectors

Contactors

Dimensions (mm)

RWM40E

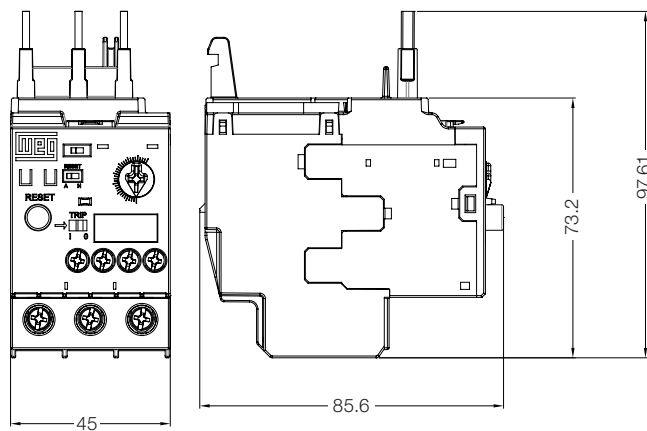

RWB40E

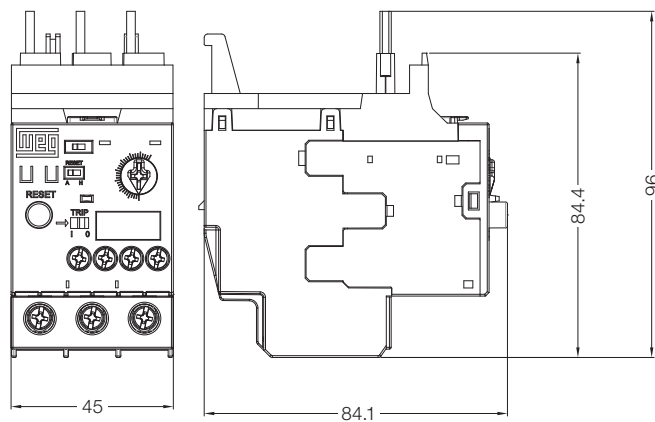

RWM40E + BF27

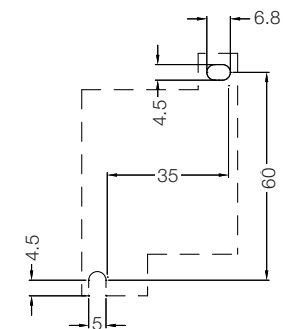
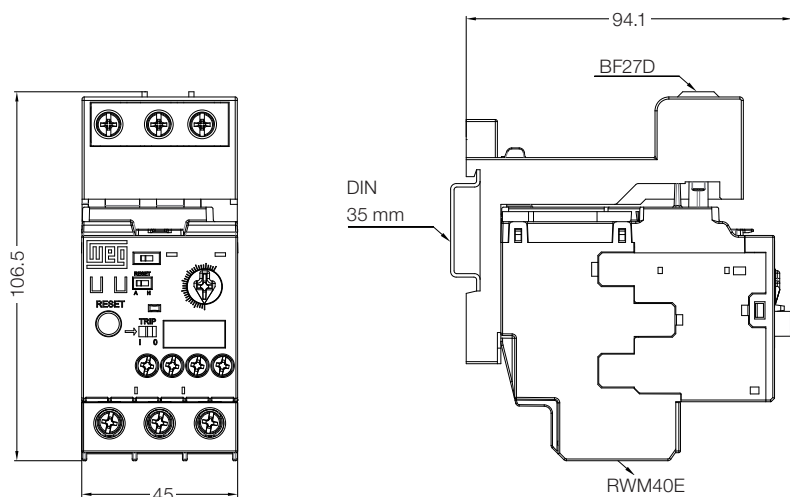

Overloads

Enclosed Starters

Relays

Pushbuttons and Pilot Lights

Terminal Blocks

Power Factor Correction

Appendix A

Appendix B

Dimensions (mm)

RWM112E

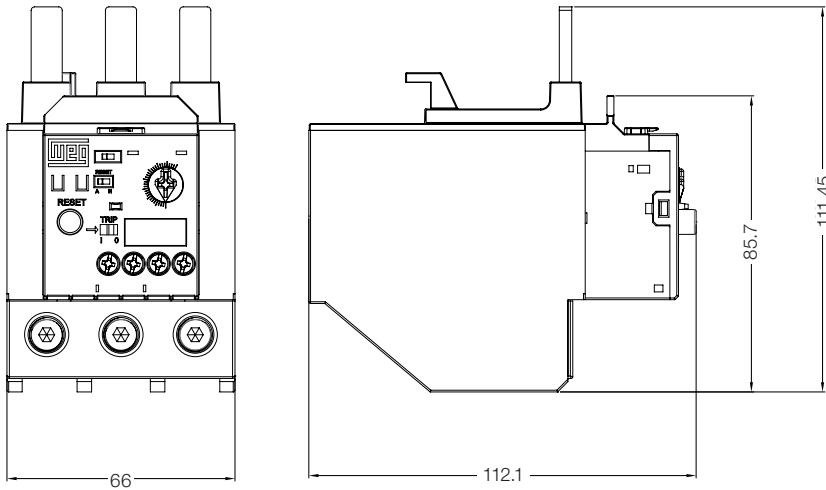

RWM112E + BF112

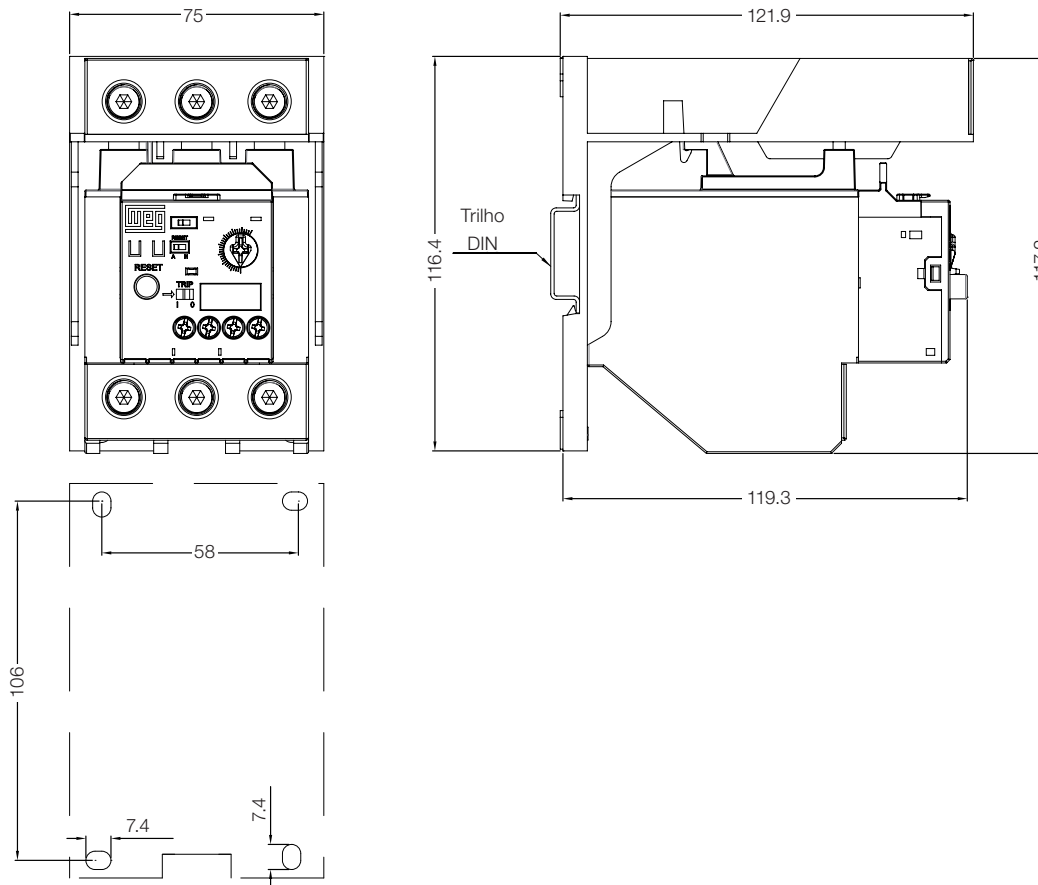

General Information

Circuit Protection

Disconnect Switches

Motor Protectors

Contactors

Overloads

Enclosed Starters

Relays

Pushbuttons and Pilot Lights

Terminal Blocks

Power Factor Correction

Appendix A

Appendix B

Overloads

RW-E Series

General Information

Circuit Protection

Disconnect Switches

Motor Protectors

Contactors

Overloads

Enclosed Starters

Relays

Pushbuttons and Pilot Lights

Terminal Blocks

Power Factor Correction

Appendix A

Appendix B

Dimensions (mm)

RWM420E

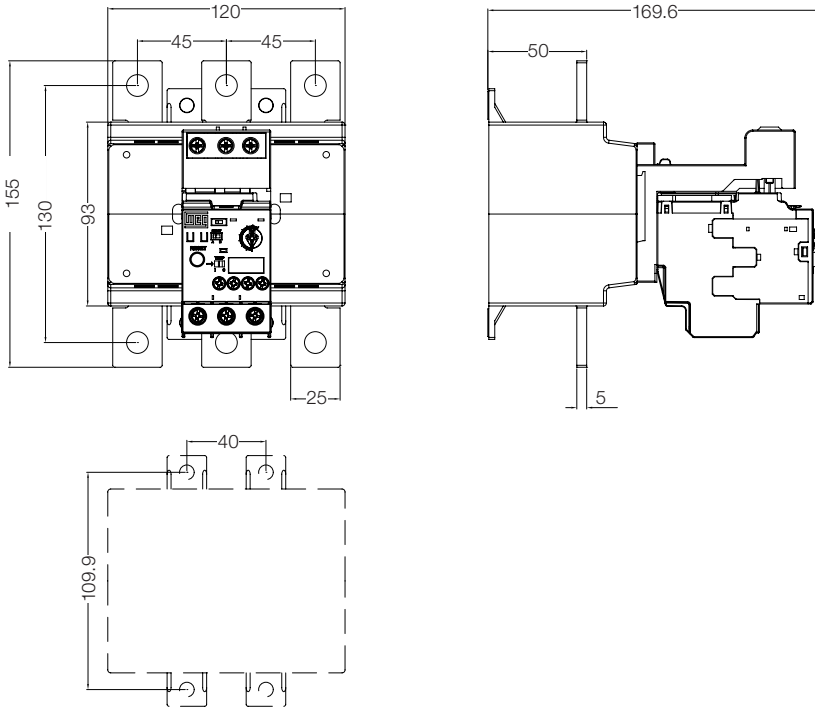

RWM840E

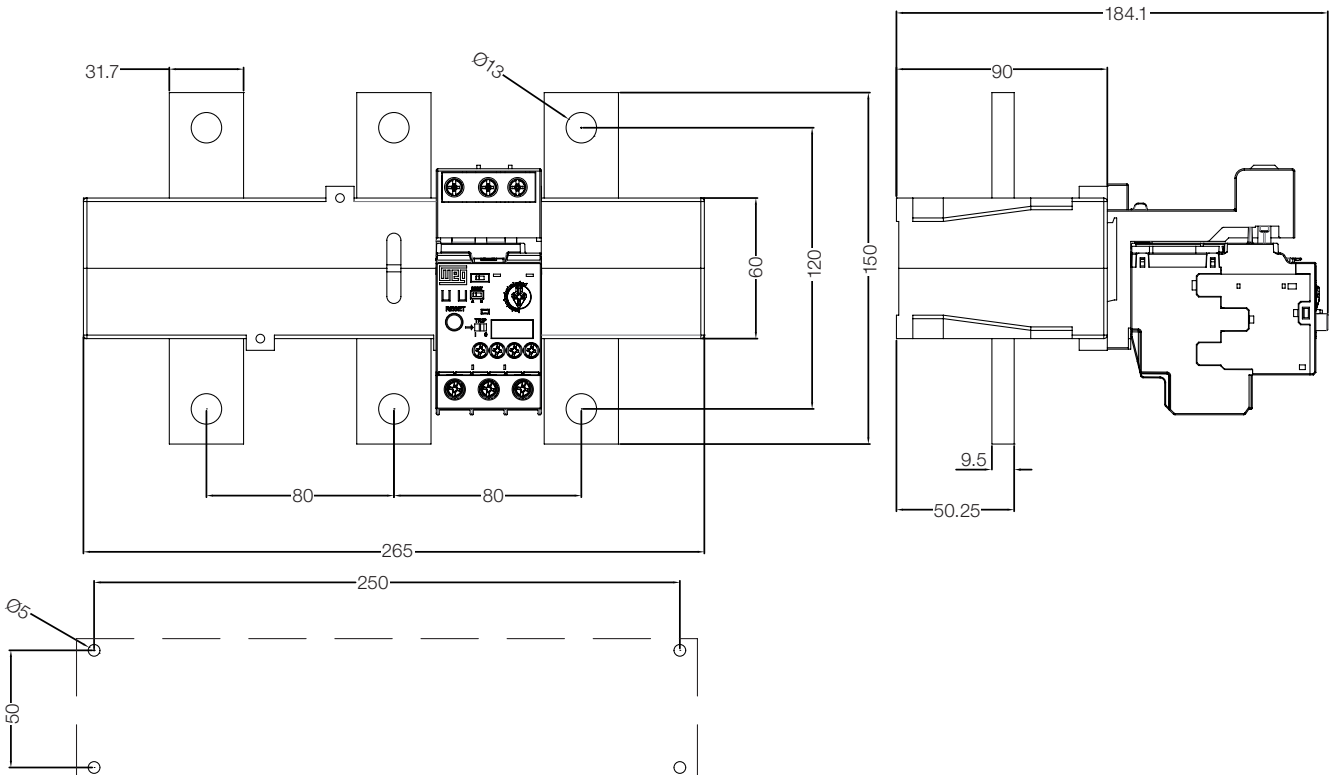

Dimensions (mm)

RWM420E + IBRW317

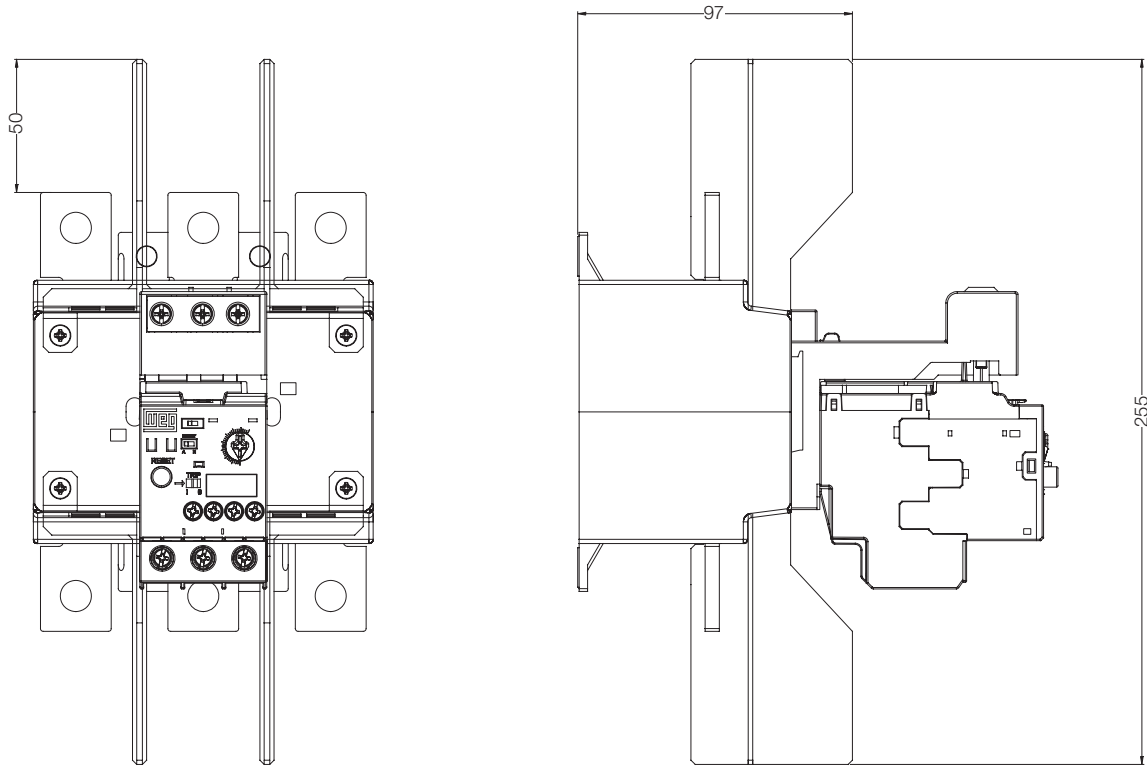

RWM40...840E / RWB40E

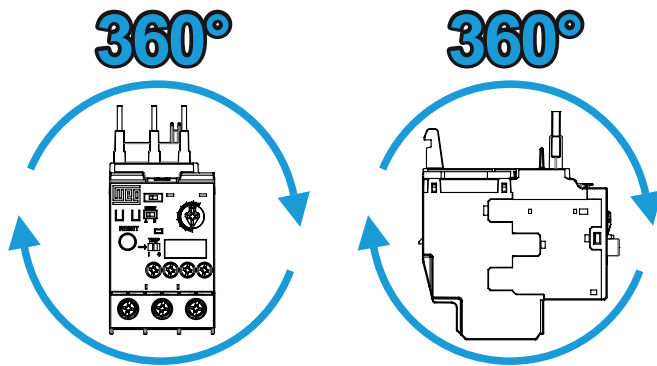

Mounting Position

General Information

Circuit Protection

Disconnect Switches

Motor Protectors

Contactors

Overloads

Enclosed Starters

Relays

Pushbuttons and Pilot Lights

Terminal Blocks

Power Factor Correction

Appendix A

Appendix B

Dimensions (mm)

CWM9...105 + RWM40...112E and CWB9...38 + RWB40E

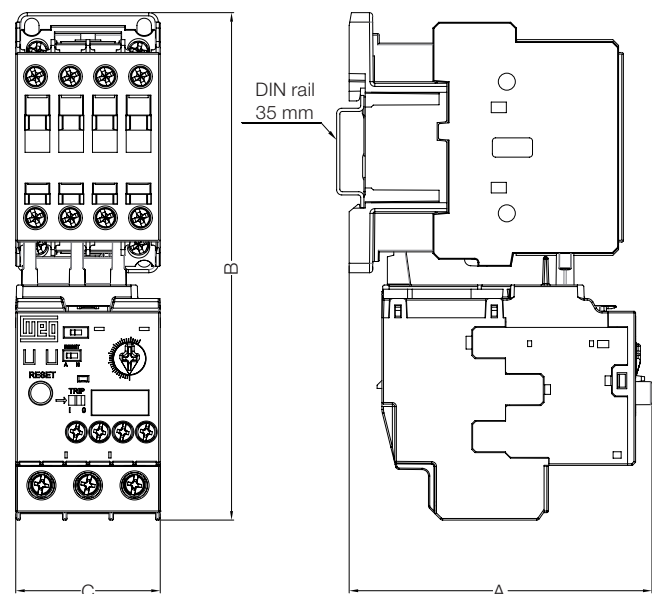

Contactor	Type of contactor coil	A	B	C
CWM9...18	CA	94.3	158	45
	CC	125.1		
CWM25	CA	94.9	159.3	45
	CC	124.8		
CWM32/40	CA	98.6	166.5	55
	CC	118.6		
CWM50...80	CA	122.6	202.7	66
	CC	118.6		
CWM95/105	CA	126	201.1	75.4
	CC	126		
CWB9...18	CA	89.5	163.1	45
	CC	98.7		
CWB25...38	CA	93	166.5	
	CC	102.2		

CWM112 + RWM112E + BF112

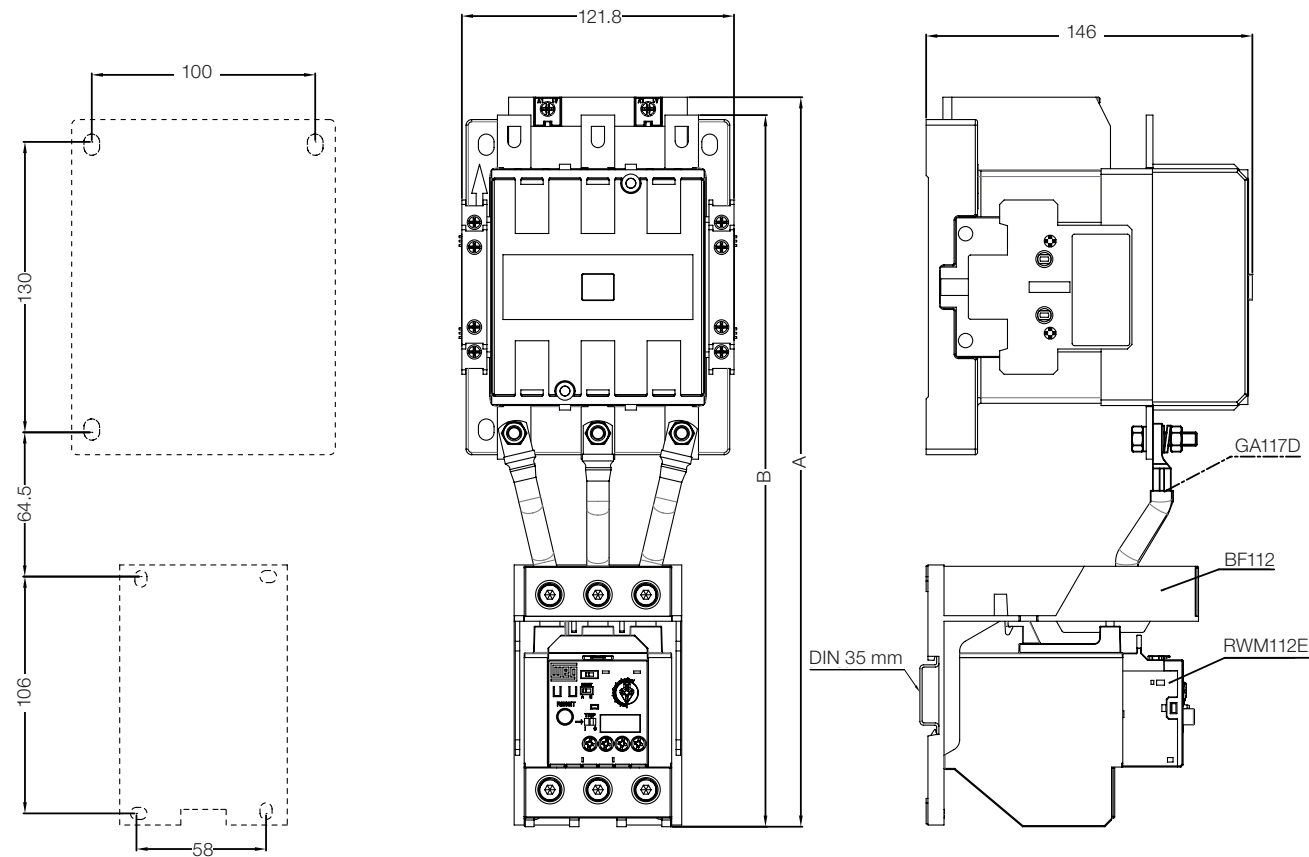

CWM112	A	B
AC conventional coil	-	318.5
Electronic coil	326.5	318.5

Dimensions (mm)

CWM112...300 + RWM112/420E

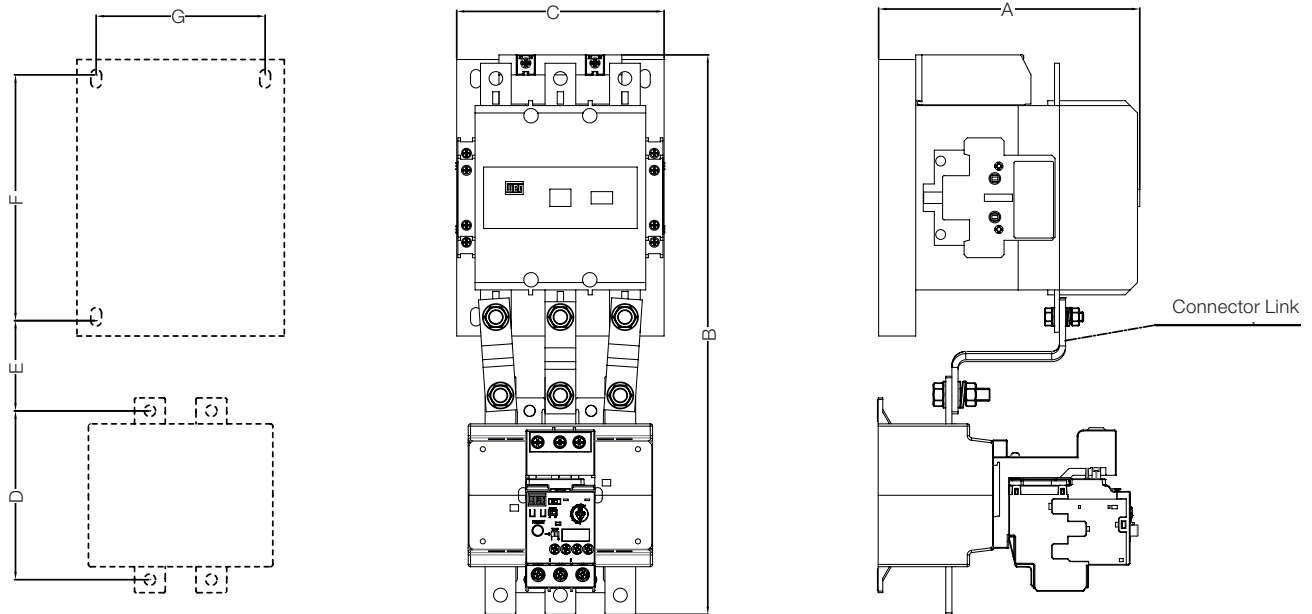

Contactor	Connector links	Overload relay	A	B	C	D	E	F	G
CWM112/150	GA117D	RWM112E	147	325	121.5	106	64	130	100
CWM112/150	GA317-1D	RW420E	166	343			60.5		
CWM180	GA317-2D	RW420E	172	358	139	110	52.5	160	110
CWM250/300	GA317-3D	RW420E	181	380	148.4		55	180	120

CWM400 + RWM420E

