

CFW500-SFY2 - Safety Functions Module

CFW500-SFY2 - Módulo de Funciones de Seguridad

CFW500-SFY2 - Módulo de Funções de Segurança

安全功能模块，CFW500-SFY2

CFW50X

Safety Manual

Manual de Seguridad

Manual de Segurança

安全手册

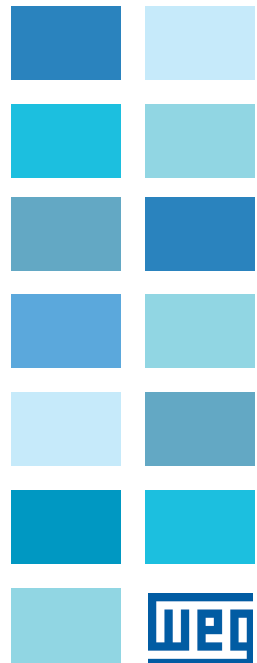



Safety Manual

Series: CFW50X

Language: English

Document: 10006503387 / 05

Date: 09/2023

The table below describes all revisions made to this manual.

Version	Manual Revision	Product Revision	Description
-	R00	A	First edition.
-	R01	A	General revision and inclusion of TÜV certificate for safety functions.
-	R02	A	General revision and mandarin language inclusion.
-	R03	A	General revision.
-	R04	A	General revision.
-	R05	A	Update of declarations and certifications. Supplementary installation information.

1 SAFETY	7
1.1 GENERAL INFORMATION	7
1.2 IMPLEMENTED SAFETY FUNCTIONS	8
1.2.1 Safe Torque Off (STO)	9
1.2.2 Safe Stop 1 Time Controlled (SS1-t)	9
1.3 SAFETY DATA	10
1.4 DECLARATION AND CERTIFICATION	11
2 INSTALLATION	15
2.1 SAFETY FUNCTIONS MODULE INSTALLATION	15
2.2 SAFETY FUNCTIONS MODULE CONNECTIONS	16
2.3 TYPES OF INSTALLATION	17
2.4 SAFETY FUNCTIONS MODULE CONFIGURATION.....	20
2.4.1 DIP Switches S1.....	20
2.4.2 DIP Switches S2.....	21
3 COMMISSIONING.....	23
3.1 PARAMETERS RELATED TO THE SAFETY FUNCTIONS MODULE	23
3.1.1 Parameters.....	23
3.2 START-UP.....	25
3.3 CONFIGURING THE SAFETY FUNCTION	26
4 MAINTENANCE AND TROUBLESHOOTING	29
4.1 MAINTENANCE	29
4.2 ALARMS AND FAULTS RELATED TO THE SAFETY FUNCTIONS MODULE	30
5 DECOMMISSIONING.....	32

1 SAFETY

1.1 GENERAL INFORMATION

**NOTE!**

These are the original instructions.

This safety manual provides the information necessary to install, configure and operate the CFW50X frequency inverters equipped with the CFW500-SFY2 safety functions module and must be used together with the other manuals of the CFW50X. Please refer to the user's manual and the programming manual of the CFW50X for further details on installation, start-up, technical features, troubleshooting and programming. All manuals are available for download on website: www.weg.net.

**NOTE!**

Use the CFW500-SFY2 safety functions module only on WEG frequency inverters from the CFW50X series.

**DANGER!**

- Only duly qualified personnel, familiar with Functional Safety, with the CFW50X frequency inverter, as well as any related equipment must plan or perform the installation, commissioning, operation and maintenance of this equipment.
- Personnel must follow the safety instructions described in this manual and/or defined by local standards.
- Noncompliance with the safety instructions may result in death risk and/or equipment damage.

**NOTE!**

For the purposes of this manual, qualified personnel are those trained in order to be able to:

1. Install, ground, power up and operate the CFW50X in accordance with this manual and the safety legal procedures in force.
2. Use the protective equipment according to the relevant standards.
3. Give first aid.

**DANGER!**

- Always disconnect the general power supply before touching any electrical component associated with the frequency inverter.
- Many components may remain charged with high voltages and/or moving (fans), even after the power supply input is disconnected or turned off.
- Wait for at least ten minutes so as to guarantee the full discharge of the capacitors.
- Always connect the equipment to the protective earth (PE) at the appropriate point.

**ATTENTION!**

The electronic boards have components sensitive to electrostatic discharges. Do not touch directly the components or connectors. If necessary, use proper grounding strap.

1.2 IMPLEMENTED SAFETY FUNCTIONS

When equipped with the CFW500-SFY2 safety functions module, the CFW50X frequency inverter is able to perform two standardized safety stopping functions:

1. Safe torque off (STO) according to IEC/EN 61800-5-2 or Stop category 0 according to IEC/EN 60204-1.
2. Safe stop 1 time controlled (SS1-t) according to IEC/EN 61800-5-2 or Stop category 1 according to IEC/EN 60204-1.

**ATTENTION!**

Even when the safety stop function is active, dangerous voltage levels may be present in the motor. Thus, before any intervention on electrical parts, the system must be completely de-energized.

**ATTENTION!**

In applications where external influences are relevant (e.g. fall of suspended loads), additional measures (e.g. use of mechanical brakes) may be necessary to prevent any hazard. The risk analysis must be performed by the end user in order to identify and cover all possible hazards and risks in the application.

**NOTE!**

The safety stop functions should not be used as a control for starting and/or stopping the motor.

**NOTE!**

The safety stop functions take priority over all other functions of the frequency inverter.

**NOTE!**

The safety of the entire system depends on the final certification of the equipment where the frequency inverter is applied. WEG is not liable for damages and/or losses during the use or application of the frequency inverter. For these reasons, WEG cannot be held accountable for applications based on the figures and examples described in this manual, which are presented for illustrative purposes only.

1.2.1 Safe Torque Off (STO)

The STO safety function acts on the removal of torque from the motor, i.e., no power that can generate torque is present on the motor after enabling this function. The difference between STO and other ways to disable the motor is that the former does it with very high levels of reliability against unexpected motor starts, even under a fault condition - refer to [Section 1.3 SAFETY DATA](#) on page 10.

Once activated, the STO safety function removes the power from the frequency inverter's output electronic circuit, causing the motor to coast to a stop - see [Figure 1.1](#) on page 9.

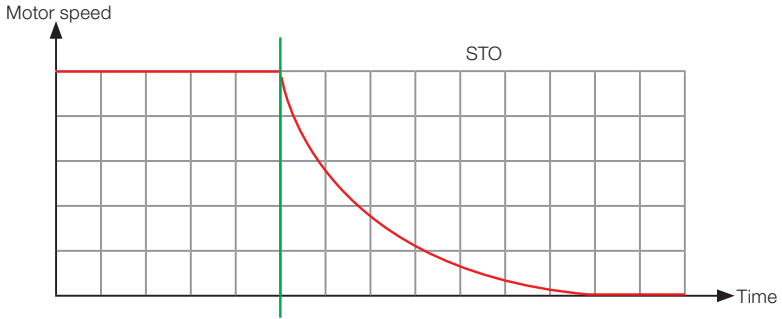

Figure 1.1: STO behavior

1.2.2 Safe Stop 1 Time Controlled (SS1-t)

Differently from the STO safety function, which, when active, must promptly ensure that there is no torque-generating energy at the frequency inverter output, the SS1-t safety function, when active, will wait a predefined delay time before performing the STO, in order to allow the frequency inverter to impose a deceleration ramp to the motor before removing the torque-generating energy. The SS1-t is especially useful in applications where inertial loads need to be decelerated before torque is removed from the motor.

[Figure 1.2](#) on page 9 illustrates the behavior of the SS1-t safety function, where it is possible to observe the controlled delay time between the green bars in the figure. The safety functions module should be configured with a time value equal to or greater than the frequency inverter's capacity to decelerate the load; otherwise, the torque-off state may be reached before the complete stop of the load.

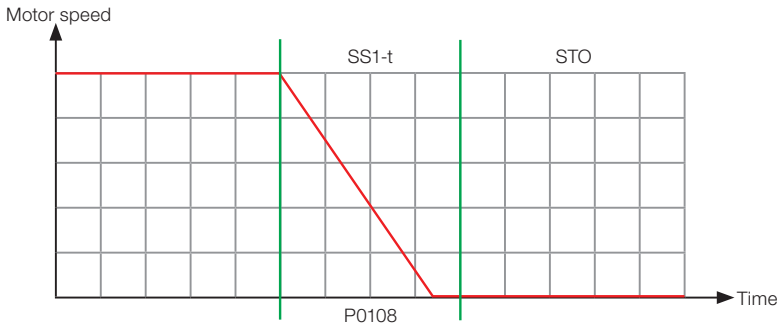

Figure 1.2: SS1-t behavior

**NOTE!**

According to IEC/EN 61800-5-2, the deceleration ramp of the SS1-t safety function may fail undetectably. Therefore, this function must not be used if this failure could cause a dangerous situation in the final application.

1.3 SAFETY DATA

The safety data for the CFW50X frequency inverter equipped with the CFW500-SFY2 is presented in [Table 1.1 on page 10](#).

Table 1.1: Safety data

Safety functions	Safe torque off (STO), as per IEC 61800-5-2 Stop category 0, as per IEC 60204-1
	Safe stop 1 time controlled (SS1-t), as per IEC 61800-5-2 Stop category 1, as per IEC 60204-1
Safety category	SIL 3, as per IEC 61508 / IEC 62061 / IEC 61800-5-2 PL e, category 4, as per EN ISO 13849-1
PFD _{avg}	$< 2.74 \times 10^{-4}$
PFH (1/h)	$< 3.11 \times 10^{-9}$
MTTF _d (y)	> 1600 years
DC _{avg}	HIGH
Proof test interval	20 years (*)
Response/reaction time	< 100 ms
OSSD test pulses	Pulse duration: < 1 ms Interval between pulses on the same channel: > 8 ms Interval between pulses on different channels: > 4 ms
Safety input signals	ON: 15 Vdc ... 30 Vdc
	OFF: < 2 V
Maximum discrepancy time between safety input signals	1 s
Safety power supply	+24 Vdc ± 15 %, SELV type according to IEC 60950-1 or PELV type according to IEC 60204-1

(*) This means that the lifetime, or mission time, of the product is limited to 20 years, i.e. the product shall be replaced after 20 years.

**NOTE!**

The control accessories of the CFW50X frequency inverter provide a +24 Vdc power supply (150 mA), which can be used to supply the CFW500-SFY2.

**NOTE!**

General data about the CFW50X frequency inverter can be found in the user's manual, available for download on the website: www.weg.net.

1.4 DECLARATION AND CERTIFICATION

EU Declaration of Conformity



We, **WEG Drives & Controls - Automação Ltda**
(manufacturer)
Av. Prefeito Waldemar Grubba, 3000
89256-900 - Jaraguá do Sul - SC - Brazil
www.weg.net

WEG GERMANY GMBH
(Authorized Representative in the Europe Union)
Industriegebiet Türnich 3, Geigerstraße 7, 50169
Kerpen Türnich - North Rhine-Westphalia - Germany
Contact person: Wilmar Henning

declare that the products:

Type: Frequency inverter

Models: CFW50x, followed by A, B, C, D, E, F or G, followed by 01P0, 01P6, 02P6, 04P3, 06P3, 06P5, 07P0, 07P3, 09P6, 10P0, 12P2, 14P0, 16P0, 17P0, 19P4, 24P0, 28P0, 31P0, 33P0, 39P0, 47P0, 49P0, 56P0, 77P0, 88P0, 0105, 0142, 0145, 0180 or 0211, followed by S, B or T, followed by 2 or 4, followed by NB or DB, followed by 20, N1 or 06, followed by C2 or C3, may be followed by Y2, may be followed by DS, may be followed by Hxx, may be followed by Sxx, followed by G2. Equipped with the safety functions module CFW500-SFY2.

when installed, maintained and used on the applications they were designed for, and in compliance with the relevant installation standards and manufacturer's instructions, comply with the relevant European Union harmonization legislation where applicable.

Directives:

2006/42/EC Machinery Directive
2014/30/EU EMC Directive
2011/65/EU + 2015/863/EU RoHS Directive
2009/125/EC Ecodesign Directive

Standards:

EN 61800-5-2:2017 / IEC 61800-5-2:2016
EN 61800-5-1:2007+A:2017 / IEC 61800-5-1:2007
EN 61800-3:2018 / IEC 61800-3:2017
EN 62061:2005+AC:2010+A1:2013+A2:2015 /
IEC 62061:2005+A1:2012+A2:2015
EN ISO 13849-1:2015
IEC/EN 61508 Parts 1-7:2010
EN IEC 63000:2016
IEC 61800-9-2:2017

Notified body: TÜV Rheinland Industrie Service GmbH, Am Grauen Stein, 51105 Köln / Germany - Notified body #: NB 0035 - Certificate: 01/20505723.01/20
This declaration of conformity is issued under the sole responsibility of the manufacturer.

Signed for and on behalf of WEG Drives & Controls - Automação Ltda

Adalberto José Rossa
Drives Development
Department Manager

Rommy Costa
Certification and Laboratory
Department Manager

Jaraguá do Sul, November 04th, 2022

UK Declaration of Conformity



We, **WEG Drives & Controls - Automação Ltda**
 (manufacturer)
 Av. Prefeito Waldemar Grubba, 3000
 89256-900 - Jaraguá do Sul – SC – Brazil
 www.weg.net

WEG (UK) Ltd
 (Authorized Representative in the UK)
 Broad Ground Road, Lakeside, Redditch, Worcestershire
 B98 8YP
 Contact person: Patrick O'Neil

declare that the products:

Models: CFW50x, followed by A, B, C, D, E or G, followed by 01P0, 01P6, 02P6, 04P3, 06P1, 06P5, 07P0, 07P3, 09P6, 10P0, 12P2, 14P0, 16P0, 17P0, 19P2, 24P0, 28P0, 31P0, 33P0, 39P0, 47P0, 49P0, 56P0, 77P0, 88P0, 01U5, 01A2, 01A5, 01B0 or 0211 followed by S, B or T, followed by 2 or 4, followed by NB or DB, followed by 20, N1 or 66, followed by C2 or C3, may be followed by Y2, may be followed by DS, may be followed by Hxx, may be followed by Sxx, followed by G2. Equipped with the safety functions module CFW500-SFY2.

Type: Frequency inverter

when installed, maintained and used on the applications they were designed for, and in compliance with the relevant installation standards and manufacturer's instructions, comply with the relevant UK Statutory Instruments and their amendments where applicable:

Regulations:

- N° 1597 The supply of Machinery (Safety) regulations 2008
 - N° 1091 The Electromagnetic Compatibility Regulations 2016
 - N° 3032 The Restriction of the Use of Hazardous Substances in Electrical and Electronic Equipment Regulations 2012
 - N° 539 The Ecodesign for Energy-Related Products and Energy Information (Amendment) (EU Exit) Regulations 2019
- Standards:
- BS EN 1800-5-2:2017
 - BS EN 61800-5-1:2007+A11:2021
 - BS EN 61800-3:2018
 - BS EN IEC 62061:2021
 - BS EN ISO 13849-1:2015
 - BS EN 61508 Parts 1-7:2010
 - BS EN 63000:2018
 - BS EN 61800-9-2:2017

UK Approved body, TÜV Rheinland UK Ltd., Friars Gate (Third floor), 1011 Stratford Road, Shirley, Solihull B90 4BN, UK. Approved Body No.: 2571 – Certificate: 01/205U/6723.0022.

Signed for and on behalf of WEG Drives & Controls - Automação Ltda

Adalberto José Rosa
 Drives Development
 Department Manager

Remy Costa
 Certification and Laboratory Department
 Manager

Jaraguá do Sul, November 04th, 2022

EC Type-Examination Certificate



Product Safety
Functional
Safety

www.tuv.com
ID 0600000000

Reg.-No.: 01/205/5723.01/20

Product tested	Safety Functions "Safe Torque Off (STO)" and "Safe Stop 1 time controlled (SS1-t)" within Frequency Inverters	Certificate holder	WEG DRIVES & CONTROLS - AUTOMAÇÃO LTDA AV. Prof. Waldemar Grubba, 3000 89256-900 Jaraguá do Sul / SC Brazil
-----------------------	---	---------------------------	--

Type designation	Safety Module CFW500-SFY2 for the CFW5XX inverter series. Details see current "Revision List"
-------------------------	--

Codes and standards	EN 61800-5-2:2017 EN 61800-5-1:2007 + A1:2017 EN 61800-3:2018 EN ISO 13849-1:2015	EN 62061:2005 + AC:2010 + A1:2013 + A2:2015 IEC 61508 Parts 1-7:2010 EN 60204-1:2018 (in extracts)
----------------------------	--	--

Intended application	The safety functions STO and SS1-t comply with the requirements of the relevant standards (Cat. 4 / PL e acc. to EN ISO 13849-1, SIL 3 / SIL CL 3 acc. to EN 61800-5-2 / IEC 61508 / EN 62061) and can be used in applications up to Cat. 4 / PL e acc. to EN ISO 13849-1 and SIL 3 acc. to EN 62061 / IEC 61508.
-----------------------------	---

Specific requirements	The instructions of the associated Installation and Operating Manual shall be considered.
------------------------------	---

It is confirmed, that the product under test complies with the requirements for machines defined in Annex I of the EC Directive 2006/42/EC.

Valid until 2024-09-25

The issue of this certificate is based upon an examination, whose results are documented in Report No. 968/FSP 1886.01/20 dated 2020-03-30.
This certificate is valid only for products which are identical with the product tested.

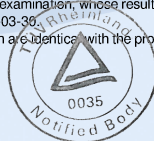

Köln, 2020-03-30

Notified Body for Machinery, NB 0035

Dipl.-Ing. Eberhard Frejno

10/22/12_12 E-A4 © TÜV, TÜV and TÜV are registered trademarks. Utilisation and application requires prior approval.

TÜV Rheinland Industrie Service GmbH, Am Gauern Stein, E1105, Köln / Germany
Tel.: +49 221 806-2454, Fax: +49 221 806-1354, E-Mail: industrie_service@de.tuv.com

www.fs-products.com
www.tuv.com

TÜVRheinland®
Precisely Right.

UK Type-Examination Certificate



For UK Regulations SI 2008 No. 1597
The Supply of Machinery Regulations 2008

Reg.-No.: 01/205U/5723.00/22

Product tested	Safety Functions "Safe Torque Off (STO)" and "Safe Stop 1 time controlled (SS1-t)" within Frequency Inverters	Certificate holder	WEG DRIVES & CONTROLS - AUTOMAÇÃO LTDA AV. Prof. Waldemar Grubba, 3000 89256-900 Jaraguá do Sul / SC Brazil
Type designation	Safety Module CFW500-SFY2 for the CFW5XX inverter series. Details see current "Revision List"		
Codes and standards	EN 61800-5-2:2017 EN 61800-5-1:2007 + A1:2017 EN 61800-3:2018	EN ISO 13849-1:2015 EN 62061:2005 + AC:2010 + A1:2013 + A2:2015 EN 61508 Parts 1-7:2010	
Intended application	The safety functions STO and SS1-t comply with the requirements of the relevant standards (Cat. 4 / PL e acc. to EN ISO 13849-1, SIL 3 / SIL CL 3 acc. to EN 61800-5-2 / IEC 61508 / EN 62061) and can be used in applications up to Cat. 4 / PL e acc. to EN ISO 13849-1 and SIL 3 acc. to EN 62061 / IEC 61508. The product can be used in the application area of EN 60204-1:2018.		
Specific requirements	The instructions of the associated Installation and Operating Manual shall be considered.		

This product is in conformity with all requirements of SCHEDULE 2, PART 1 (Annex I) of SI 2008 No. 1597.
This Type-Examination certificate refers to an evaluation of the above mentioned product as stipulated in SCHEDULE 2, PART 9 (Annex IX) of SI 2008 No. 1597.

Valid until 2024-09-25
The issue of this certificate is based upon an examination, whose results are documented in Report No. 968/FSP 1886.03/22 dated 2022-10-05.
This certificate is valid only for products which are identical with the product tested.

Köln, 2022-10-12

TUV Rheinland UK Ltd.

Approved Body for Machinery, No. 2571

Dipl.-Ing. Gebhard Bouwer

TUV Rheinland UK Ltd., Fries Gate (Third Floor), 1011 Stratford Road, Shirley, Solihull B90 4BN / United Kingdom
Tel.: +44 (0)121 796 9400, E-Mail: UKCA@tuv.com, Web: https://www.tuv.com/united-kingdom/en/

10/22/12, 12 E-A4 © TÜV, TÜEV and TÜV are registered trademarks. Utilisation and application requires prior approval.

www.fs-products.com
www.tuv.com

TÜVRheinland®
Precisely Right.

2 INSTALLATION

The inverter must be installed according to the instructions of the CFW50X user's manual.

Table 2.1 on page 15 presents the technical data related to the CFW500-SFY2 safety functions module.

Table 2.1: CFW500-SFY2 technical data

Dimensions	Figure A.3 on page 126 in Appendix A.
Mass	56 g.
Enclosure	IP20.
Operating Temperature	-10 °C ... 40 °C (14 °F ... 104 °F).
Storage Temperature	-25 °C ... 60 °C (-13 °F ... 140 °F).
Air Relative Humidity	5 % ... 95 % non-condensing.
Maximum Altitude	Up to 2000 m: nominal conditions. From 2000 m to 4000 m: voltage derating of 1.1 % for each 100 m above 2000 m.
Pollution Degree	2 (according to EN 50178 and UL 508C), with non-conductive pollution. Condensation must not originate conduction through the accumulated residues.



ATTENTION!

If the installation site does not meet the pollution degree requirements, the inverter must have an ingress protection of at least IP54 (according to IEC 60529), provided either by its enclosure or by an external cabinet.

2.1 SAFETY FUNCTIONS MODULE INSTALLATION

For the proper installation of the safety functions module, follow the steps below:

Step 1: With the CFW50X de-energized, remove the STO jumper connector locate on top of the frequency inverter according to [Figure A.1 on page 125 \(a\)](#).

Step 2: Fit and press the CFW500-SFY2 to be installed on top of the frequency inverter according to [Figure A.1 on page 125 \(b\)](#).

Step 3: Follow the energization and start-up procedure described in the CFW50X user's manual.

Step 4: Check whether parameter P0028 is showing value 1 (P0028 = 1). If this is not the case, check the connection of the CFW500-SFY2 module on top or inside of the frequency inverter and repeat the steps above.



NOTE!

Either the STO jumper connector or the CFW500-SFY2 safety functions module must be installed on top or inside of the frequency inverter. Otherwise, the fault message "F0086" will be displayed by the frequency inverter during power-on.

2.2 SAFETY FUNCTIONS MODULE CONNECTIONS

The safety-related signals must be connected to connector XC7 of the CFW500-SFY2. The location of this connector, as well as the location of the DIP switches S1 and S2, is indicated in [Figure 2.1 on page 16](#).

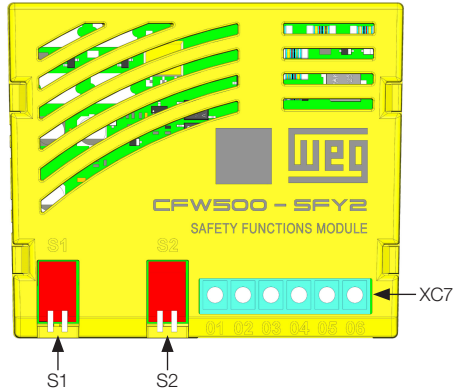

Figure 2.1: Location of connector XC7 and DIP switches S1 and S2

[Table 2.2 on page 16](#) describes the safety signals on connector XC7.

Table 2.2: Safety signals on XC7

Pin	Name	Description
1	+24 Vdc	Input for +24 Vdc PELV/SELV.
2	SP1	Safety signal for STO1 input.
3	STO1	Safety input 1.
4	SP2	Safety signal for STO2 input.
5	STO2	Safety input 2.
6	GND	Reference for +24 Vdc PELV/SELV power supply.



ATTENTION!

The safety functions of the CFW500-SFY2 are based on a dual-channel structure, which requires two independent safety inputs (STO1 and STO2). The use of dependent safety inputs (e.g. contacts of the same contactor) is not in accordance with the instructions in this manual and invalidates the safety data shown in [Table 1.1 on page 10](#).

The +24 Vdc power supply to be used with the CFW500-SFY2 must comply with the low voltage directive 2006/95/EC, applying the specifications of IEC/EN 61131-2, Programmable controllers - Part 2: Equipment requirements and tests, and it must comply with one of the following specifications:

- Safety extra-low voltage (SELV), according to IEC/EN 60950-1.
- Protected extra-low voltage (PELV), according to IEC/EN 60204-1.

NOTE!

The control accessories of the CFW50X frequency inverter provide a +24 Vdc power supply (150 mA), which can be used to supply the CFW500-SFY2.

For XC7 cabling, consider the following:

- Wire stripping length: 6.0 mm (0.236 in).
- Wire gauge from 0.5 mm² (20 AWG) to 1.5 mm² (16 AWG).
- Maximum tightening torque of 0.40 Nm (3.5 lbf.in).
- Run the cables separated from the remaining circuits (power, 110 V / 220 V control, etc.).

NOTE!

The other control signals that are not related to safety (digital/analog inputs and outputs) are connected to one of the control accessories of the frequency inverter. The cables for these control signals must not exceed 30 m when the CFW50X frequency inverter is equipped with the CFW500-SFY2.

NOTE!

On installation sites where contactors are present, it is recommended the use of surge suppressor blocks for the contactors, in order to prevent the occurrence of spurious trips of fault F0160.

2.3 TYPES OF INSTALLATION

There are two types of installation, depending on the type of the safety device that requests the safety function:

- Installation with dry contact devices, i.e. devices that have electromechanical output (conventional relays, for example).
- Installation with OSSD (Output Signal Switching Device), i.e. solid-state devices that have outputs containing test pulses (light curtain, for example).

Figure 2.2 on page 17 illustrates the installation with dry contacts, and Table 2.3 on page 18 describes its operation.

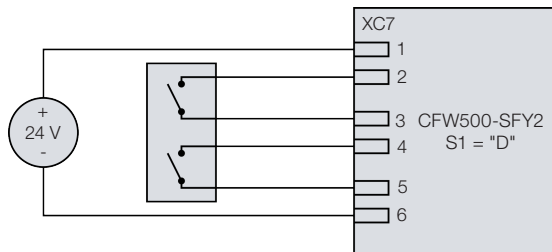

Figure 2.2: Installation using dry contacts

Table 2.3: Truth table for dry contacts operation

STO1 (contact between XC7:2 and XC7:3)	STO2 (contact between XC7:4 and XC7:5)	Safety Stop Function	Frequency Inverter Behavior
Open	Open	Enabled	Frequency inverter remains in the safe state. Starting commands are not accepted in this state. HMI display indicates alarm A0160.
Open	Closed	Fault	Frequency inverter trips to fault F0160 if such input configuration lasts longer than 1 s. To reset this fault, STO1 and STO2 must be in the same logical state and the frequency inverter must be de-energized and re-energized.
Closed	Open		
Closed	Closed	Disabled	Frequency inverter operates normally, accepting starting commands.

Figure 2.3 on page 18 illustrates the installation with OSSD, and Table 2.4 on page 18 describes its operation.

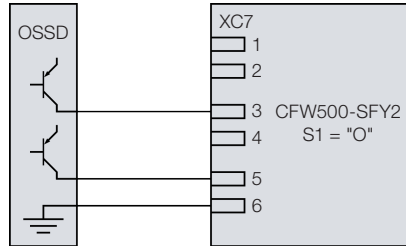

Figure 2.3: Installation using OSSD signals

Table 2.4: Truth table for OSSD signals

STO1 (voltage on XC7:3)	STO2 (voltage on XC7:5)	Safety Stop Function	Frequency Inverter Behavior
0 V	0 V	Enabled	Frequency inverter remains in the safe state. Starting commands are not accepted in this state. HMI display indicates alarm A0160.
0 V	+24 V	Fault	Frequency inverter trips to fault F0160 if such input configuration lasts longer than 1 s. To reset this fault, STO1 and STO2 must be in the same logical state and the frequency inverter must be de-energized and re-energized.
+24 V	0 V		
+24 V	+24 V	Disabled	Frequency inverter operates normally, accepting starting commands.

In OSSD installations, it is possible to connect multiple frequency inverters to a single safety actuator, as shown in Figure 2.4 on page 19. The maximum number of frequency inverters that can be connected in parallel is determined by the current capacity of the safety actuator, with each safety input channel consuming up to 15 mA, i.e. 30 mA per frequency inverter.

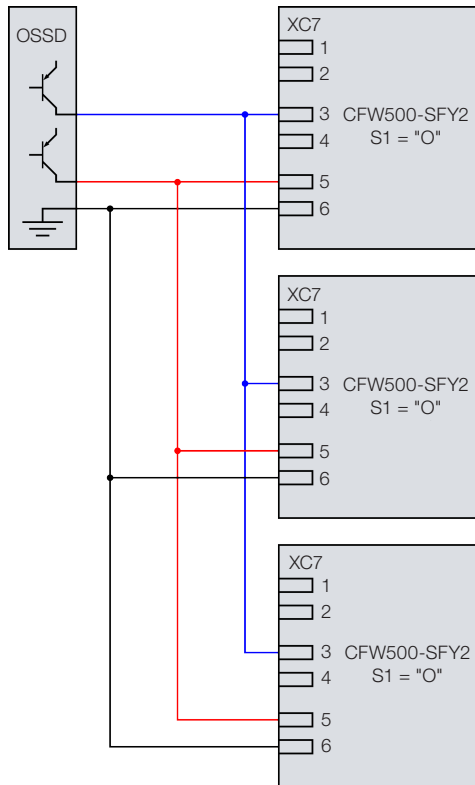

Figure 2.4: Installation of multiple frequency inverters (OSSD only)



ATTENTION!

Connecting multiple frequency inverters with a dry-contact actuator is not permitted.

2.4 SAFETY FUNCTIONS MODULE CONFIGURATION

2.4.1 DIP Switches S1

In order to configure the CFW500-SFY2 safety functions module for the appropriate type of installation, the DIP switches S1 must be set before energization, according to [Table 2.5 on page 20](#), where "D" stands for "dry contacts" and "O" stands for "OSSD".



NOTE!

Setting the DIP switches S1 to "D" or "O" after energization has no effect on the equipment.

Table 2.5: DIP switches S1

Configuration	Description
	<p>Both DIP switches set to "D" (dry contact). This configuration must be chosen when the safety signals are controlled by dry contacts as shown in Figure 2.2 on page 17.</p>
	<p>One DIP switch set to "D" (dry contact) and the other set to "O" (OSSD). This is not a valid combination and results in a fault state (F0160), displayed on the frequency inverter after the energization. The frequency inverter will not work.</p>
	<p>One DIP switch set to "D" (dry contact) and the other set to "O" (OSSD). This is not a valid combination and results in a fault state (F0160), displayed on the frequency inverter after the energization. The frequency inverter will not work.</p>
	<p>Both DIP switches set to "O" (OSSD). This configuration must be chosen when safety signals are controlled by an OSSD output, as shown in Figure 2.3 on page 18.</p>

2.4.2 DIP Switches S2

The DIP switches S2 control the access to the programming mode of the CFW500-SFY2, which enables the selection of which safety function will be used, as well as the definition of the delay time in case of SS1-t. The programming procedure is described in details in [Section 3.3 CONFIGURING THE SAFETY FUNCTION](#) on page 26.

Table 2.6: DIP switches S2

Configuration	Description
	<p>Both DIP switches set to ON.</p> <p>This configuration activates the programming mode of the CFW500-SFY2, displaying alarm A0162 on HMI. For programming the safety functions module, proceed according to Section 3.3 CONFIGURING THE SAFETY FUNCTION on page 26.</p>
	<p>One DIP switch set to ON and the other to OFF.</p> <p>This is not a valid combination and the programming cannot be completed.</p>
	<p>One DIP switch set to ON and the other to OFF.</p> <p>This is not a valid combination and the programming cannot be completed.</p>
	<p>Both DIP switches set to OFF.</p> <p>This configuration disables the programming mode of the CFW500-SFY2.</p>



NOTE!

The DIP switches S2 must only be set to the ON position when CFW500-SFY2 is in the safe state, which is indicated by alarm A0160 on HMI. Trying to enter the programming state from any state other than the safe state will result in the fault state, which is indicated by fault F0160 on HMI.

3 COMMISSIONING

3.1 PARAMETERS RELATED TO THE SAFETY FUNCTIONS MODULE

The parameters of the CFW50X frequency inverter that are directly related to the safety functions module are presented below.

Symbols used to describe parameter properties:

- ro: read only parameter.
- sy: parameter only visible on HMI when the safety functions module is in the programming mode.

3.1.1 Parameters

P0028 - Safety Functions Module

Adjustable Range:	0 = STO Jumper Connector 1 = CFW500-SFY2	Factory Setting:
Properties:	ro	
Access Groups via HMI:	<input type="text" value="READ"/>	

Description:

It identifies the safety functions module connected to the frequency inverter, according to [Table 3.1 on page 23](#).

Table 3.1: Identification of the safety functions module

Name	Description	P0028
STO Jumper Connector	Frequency inverter without functional safety.	0
CFW500-SFY2	Frequency inverter is equipped with a safety functions module capable of performing STO and SS1-t.	1



NOTE!

Either the STO jumper connector or the CFW500-SFY2 must be installed on top or inside of the frequency inverter. Otherwise, the fault message "F0086" will be displayed by the frequency inverter during power-on.

P0106 - 3rd Ramp Time

Adjustable Range:	0.1 to 999.0 s	Factory Setting: 5.0 s
Properties:		
Access Groups via HMI:		

Description:

It defines the acceleration time from zero to maximum speed (P0134) or deceleration from maximum speed (P0134) to zero for the 3rd Ramp.

**NOTE!**

The frequency inverter uses the 3rd Ramp to decelerate the motor when the SS1-t safety function is requested. Therefore, when using SS1-t, only modify this parameter during the configuration of the CFW500-SFY2.

P0108 - SS1-t Time

Adjustable Range:	0 to 999 s	Factory Setting:	0 s
Properties:	sy		
Access Groups via HMI:			

Description:

It defines the delay time of the SS1-t safety function to be programmed in the safety functions module. If the delay time value is 0 seconds, the safety functions module is programmed with the STO safety function.

**NOTE!**

P0108 is only visible on HMI and, therefore, can only be modified when the safety functions module is in the programming mode.

P0109 - SS1-t Time Confirmation

Adjustable Range:	0 to 999 s	Factory Setting:	
Properties:	ro, sy		
Access Groups via HMI:			

Description:

During the programming procedure of the safety functions module, it indicates the actual value of the delay time programmed in the safety module for the user's confirmation.

**NOTE!**

P0109 is only visible on HMI and, therefore, can only be accessed when the safety functions module is in the programming mode.

3.2 START-UP

Start-up sequence:

- 1) Execute the mechanical and electrical installation of the frequency inverter according to the CFW50X user's manual and the safety manual.
- 2) Configure the DIP switches S1 according to the type of safety signal (dry contact or OSSD), and set the DIP switches S2 to OFF.
- 3) Set the safety inputs to the safe state, i.e. open contacts or apply 0 V on STO1 and STO2.
- 4) Make sure the motor is not coupled to the machine or, if coupled, it must be able to rotate in any direction without any risk of human harm or machine damage.
- 5) Energize the frequency inverter.
- 6) Load CFW50X factory default parametrization via P0204 and check that parameter P0028 indicates 1 (CFW500-SFY2).
- 7) Program the frequency inverter according to the application requirements.
- 8) If the SS1-t safety function is required, follow the steps described in [Section 3.3 CONFIGURING THE SAFETY FUNCTION on page 26](#).
- 9) Set the safety inputs to the operational state, i.e. close contacts or apply +24 V on STO1 and STO2 simultaneously.
- 10) Check if the motor runs and stops by pressing the "I" and "O" keys of the HMI.
- 11) Run the motor and set the safety inputs to the safe state, i.e. open contacts or apply 0 V on STO1 and STO2 simultaneously.
- 12) Check if the motor stops when the safe state is activated, indicating alarm A0160 on the HMI.
- 13) Set the safety inputs to the operational state, i.e. close contacts or apply +24 V on STO1 and STO2 simultaneously.
- 14) Check if the motor runs again using the "I" and "O" keys.
- 15) Check all other application functionalities in order to ensure the correct behavior and the overall safety of the system in which CFW50X is installed.



ATTENTION!

The steps above are the minimum necessary to verify the integrity of the frequency inverter's safety function. In order to verify the overall operation and safety of the machine or system, other steps may be necessary. The machine manufacturer is responsible for the final verification and certification of the safety of the machine or system where the frequency inverter is applied.



ATTENTION!

Whenever the safety function is reconfigured, it is mandatory to carry out an operation verification test.

**NOTE!**

Simultaneously activation of the safety inputs means that the time between the activation or deactivation of the inputs must be less than 1 s. This time is also known as discrepancy time. If the discrepancy time exceeds 1 s, fault F0160 will be displayed on the HMI. To reset this fault, it is necessary to set both safety inputs (STO1 and STO2) to the same logical state, and then de-energize and re-energize the frequency inverter.

**NOTE!**

Test pulses present in OSSD outputs are tolerated and do not activate the safety functions, provided that they respect the following specifications:

- Pulse duration: < 1 ms.
- Interval between pulses on the same channel: > 8 ms.
- Interval between pulses on different channels: > 4 ms.

3.3 CONFIGURING THE SAFETY FUNCTION

The controlled delay time of the SS1-t safety function is used to select which safety function is configured in CFW500-SFY2. If the delay time is programmed with 0 s, then STO is selected; on the other hand, values from 1 s to 999 s configure the SS1-t safety function.

**NOTE!**

The factory default value for the controlled delay time is 0 s, i.e. the CFW500-SFY2 is pre-configured with the STO safety function.

The delay time is programmed by setting the DIP switches S2 of the CFW500-SFY2 and defining the parameters P0106, P0108 and P0109 via HMI, according to the procedure below.

- 1) Perform the start-up sequence described in [Section 3.2 START-UP on page 25](#).
- 2) Make sure the frequency inverter is in the safe state, i.e. the safety inputs are deactivated and the HMI displays alarm A0160.

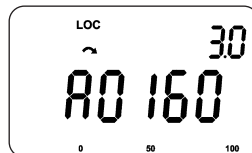

- 3) Set both DIP switches S2 to the "ON" position. The HMI must display alarm A0162, which means the safety functions module entered the programming mode.

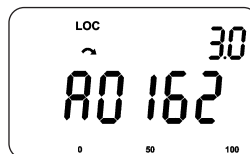
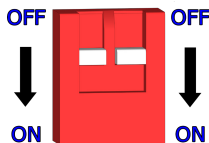

- 4) Set parameter P0108 to the desired delay time value, for example, 15 s, as shown below. Then, press the "ENTER" key. At this point, the display backlight starts to flash and the user must confirm the programmed value by means of parameter P0109.

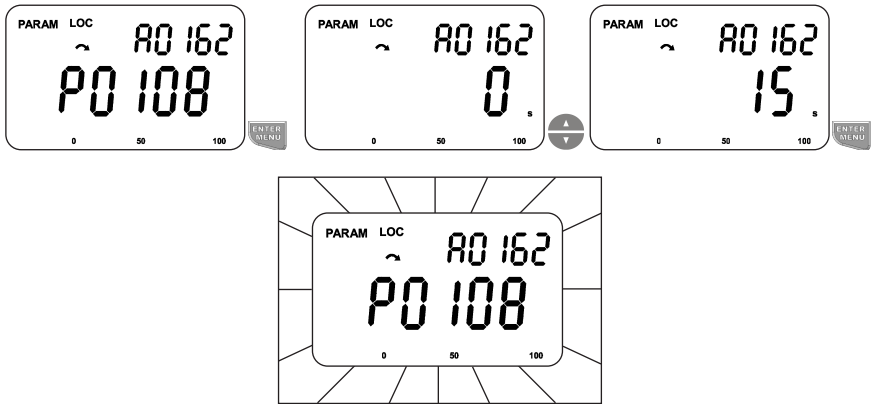

- 5) To confirm the programmed value, access parameter P0109 and check if the displayed value in P0109 is the same as that programmed in P0108. If the values are the same, press the "ENTER" key to confirm. At this point, the display back should stop blinking. In case of different values for P0108 and P0109, the user must press the "ESC" key, which aborts the programming procedure and trips fault F0160.

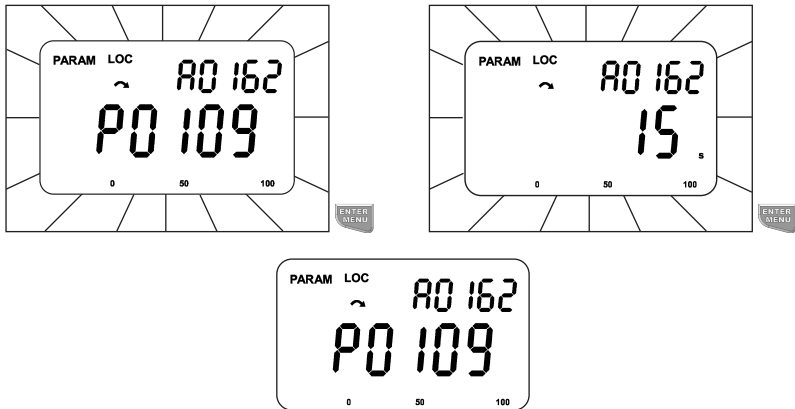
NOTE!

If the programming procedure of the delay time fails or is aborted, the last programmed value is kept.



NOTE!

If the programming procedure stays idle for more than 2 minutes, the frequency inverter trips fault F0160. To reset this fault, de-energize and re-energize the frequency inverter.

**NOTE!**

If the user confirms a value in P0109 which is different from that just programmed in P0108, the frequency inverter trips fault F0160. To reset this fault, de-energize and re-energize the frequency inverter.

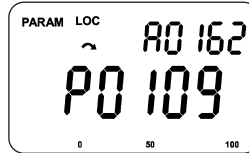
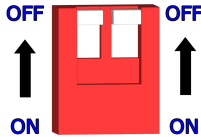
- 6) After programming and confirming the delay time value, the user must return the DIP switches S2 to the "OFF" position. At this point, the frequency inverter exits the programming mode (A0162) and returns to the safe state (A0160).



- 7) Set the deceleration time on parameter P0106 for the deceleration ramp that the frequency inverter will execute during a demand of the SS1-t safety function.

**NOTE!**

For the STO safety function, parameter P0106 is irrelevant for the safety function performance and this step can be skipped.

- 8) Set the safety inputs to the operational state. The frequency inverter should clean alarm A160 from the HMI display.
- 9) Press "I" key on the HMI to run the motor.
- 10) While the motor is running, set the safety inputs back to the safe state, checking if the SS1-t delay time (P0108) and the deceleration ramp imposed by the frequency inverter (P0106), if applicable, are suitable for the application. If not, repeat this programming procedure with appropriate time values.

**NOTE!**

During the timing of the SS1-t safety function (delay time), alarm A0161 is displayed on the HMI. After this delay time, the HMI displays alarm A0160.

**NOTE!**

Setting the frequency inverter to its factory default parametrization via parameter P0204 does not affect the programmed delay time in the CFW500-SFY2 safety functions module.

**NOTE!**

Copying parameters via CFW500-MMF (flash memory module) does not affect the programmed delay time in the CFW500-SFY2 safety functions module.

4 MAINTENANCE AND TROUBLESHOOTING

4.1 MAINTENANCE

The CFW50X frequency inverter is equipped with several self-diagnosis functions and HMI display messages to help the user identify problems with the frequency inverter or its installation.

The CFW500-SFY2 safety functions module, in particular, is equipped with a very accurate self-diagnosis circuit, which guarantees high levels of safety even under fault conditions. Faults related to safety are reported as "F0160", which include misconnections of the safety signals, errors in the safety functions module configuration and damages in the internal circuits. See [Section 4.2 ALARMS AND FAULTS RELATED TO THE SAFETY FUNCTIONS MODULE on page 30](#) for the most common causes for fault F0160.

If fault F0160 is shown on the frequency inverter display and no external problem can be identified, then it is possible that there is an internal problem in the safety functions module. In this case, the frequency inverter must be taken out of operation and then submitted to an authorized service center. Contact your local WEG supplier to get information on how to proceed.

**NOTE!**

Never try to fix or allow a non-authorized person to fix any WEG products. The safety assurance of this frequency inverter is automatically lost if any product violation occurs.

**NOTE!**

There are no spare parts for the CFW500-SFY2 safety functions module. In case of damage, it must be replaced by a new one.

**NOTE!**

The functional safety circuits of the frequency inverter were designed in such a way that no maintenance or regular tests are necessary. The circuits check themselves at periodic intervals informing the user if any problem is detected.

**NOTE!**

When the CFW500-SFY2 safety functions module detects a fault condition and the SS1-t safety function is used, the frequency inverter attempts to execute the deceleration of the motor (A0161) before the actuation of fault F0160, similarly to what occurs when the SS1-t safety function is normally activated by the safety inputs.

**NOTE!**

Fault F0160 also represents a safe torque-off state.

**NOTE!**

In case of maintenance of the machine or system, the overall safety must be rechecked in order to verify the safety integrity of the machine or system. Additionally, in case of any modification, the validation of the safety function must be repeated and documented.

**ATTENTION!**

If a simultaneous fault occurs on two or more IGBTs of the frequency inverter during the activation of the safety function, it is possible that the frequency inverter delivers sufficient energy to cause a magnetic alignment between the rotor and the internal magnetic poles of the motor. This movement depends on the number of poles of the motor and is limited to a maximum of 180°. Although this event is unlikely, be sure that this possibility cannot cause harm to people or damages to machinery.

4.2 ALARMS AND FAULTS RELATED TO THE SAFETY FUNCTIONS MODULE

A0160 - Safe State Active

Description:

It indicates to the user that the safe state is active.

Possible Causes/Correction:

- Actuation of the safety inputs (STO1 and STO2).
- Safety input circuit not installed.
- Safety input circuit de-energized.

A0161 - SS1-t Timing Active

Description:

It indicates to the user that the safety functions module is executing the timing of the SS1-t safety function, while the frequency inverter decelerates the motor.

Possible Causes/Correction:

- Actuation of the safety inputs (STO1 and STO2) with the SS1-t safety function configured.
- Fault detected with the SS1-t safety function configured.

A0162 - Safety Functions Module in Programming Mode

Description:

It indicates to the user that the safety functions module is in the programming mode of the safety functions.

Possible Causes/Correction:

- Activation of the programming DIP switches (S2) of the safety functions module during the safe state.

F0160 - Safety Functions Module in Fault State**Description:**

It indicates to the user that the safety functions module is in the fault state.

Possible Causes/Correction:

- Incorrect installation of the safety input circuit.
- Discrepancy between the safety inputs (STO1 and STO2) greater than 1 s.
- Incorrect configuration of safety input type (dry contact or OSSD) on DIP switches S1.
- Safety functions module programming DIP switches (S2) activated in operational state.
- Incorrect programming of the safety function or programming timeout (2 min).
- Electronic circuit of the safety functions module damaged.

F0161 - Safety Functions Module Communication Fault**Description:**

It indicates to the user that the inverter has lost communication with the safety functions module.

Possible Causes/Correction:

- Poor contact between the safety functions module and the frequency inverter.
- Damage in the electronic circuits of the frequency inverter control or the safety functions module.

5 DECOMMISSIONING

For decommissioning, the machine or system shall preferably be switched off from any type of energy supply. If this is not possible, all electrical connections, i.e. power connections and the control connections of the frequency inverter, must be switched off before any decommissioning activities on the frequency inverter.

**DANGER!**

Before decommissioning, it is necessary to make an analysis of the safety of the machine or system. Hanging loads, brakes or rotating parts may require energy to stay in a safe state and the power removal can lead to unsafe conditions. Be sure that power removal can be realized in a safe way.

**DANGER!**

Even after switching off or disconnecting the power supply, the frequency inverter may remain charged with high voltages and/or have moving parts (fans). Wait for at least 10 minutes in order to guarantee the full discharge of internal components.



Manual de Seguridad

Série: CFW50X

Idioma: Español

Documento: 10006503387 / 05

Fecha: 09/2023

La información a seguir describe las revisiones llevadas a cabo en este manual.

Versión	Revisión del Manual	Revisión del Producto	Descripción
-	R00	A	Primera edición.
-	R01	A	Revisión general e inclusión del certificado TÜV para las funciones de seguridad.
-	R02	A	Revisión general y inclusión del idioma mandarín.
-	R03	A	Revisión general.
-	R04	A	Revisión general.
-	R05	A	Actualización de declaraciones y certificaciones. Información adicional de instalación.

1 SEGURIDAD	37
1.1 INFORMACIONES GENERALES	37
1.2 FUNCIONES DE SEGURIDAD IMPLEMENTADAS.....	38
1.2.1 Safe Torque Off (STO)	39
1.2.2 Safe Stop 1 Time Controlled (SS1-t)	39
1.3 DATOS DE SEGURIDAD	40
1.4 DECLARATION Y CERTIFICACION	41
2 INSTALACIÓN	45
2.1 INSTALACIÓN DEL MÓDULO DE FUNCIONES DE SEGURIDAD	45
2.2 CONEXIONES DEL MÓDULO DE FUNCIONES DE SEGURIDAD.....	46
2.3 TIPOS DE INSTALACIÓN.....	47
2.4 CONFIGURACIÓN DEL MÓDULO DE FUNCIONES DE SEGURIDAD...50	
2.4.1 DIP Switches S1.....	50
2.4.2 DIP Switches S2.....	51
3 PUESTA EN FUNCIONAMIENTO.....	53
3.1 PARÁMETROS RELACIONADOS AL MÓDULO DE FUNCIONES DE SEGURIDAD.....	53
3.2 PUESTA EN FUNCIONAMIENTO	54
3.3 PROGRAMACIÓN DE LA FUNCIÓN DE SEGURIDAD	56
4 MANTENIMIENTO Y DIAGNÓSTICO DE PROBLEMA	59
4.1 MANTENIMIENTO	59
4.2 ALARMAS Y FALLAS RELACIONADAS AL MÓDULO DE FUNCIONES DE SEGURIDAD.....	60
5 DESMONTAJE	62

1 SEGURIDAD

1.1 INFORMACIONES GENERALES

**¡NOTA!**

Estas son las instrucciones originales.

Este manual de seguridad presenta la información necesaria para instalar, configurar y operar el convertidor de frecuencia con el módulo de funciones de seguridad CFW500-SFY2 y debe utilizarse junto con los demás manuales del CFW50X. Consulte el manual del usuario y el manual de programación del CFW50X para más detalles de la instalación, puesta en funcionamiento, características técnicas, diagnósticos de problemas y programación. Todos los manuales están disponibles para descargar en el sitio: www.weg.net.

**¡NOTA!**

Utilice el módulo de funciones de seguridad CFW500-SFY2 sólo con convertidores de frecuencia de la línea CFW50X.

**¡PELIGRO!**

- Solo el personal debidamente calificado, familiarizado con seguridad funcional y el convertidor CFW50X, así como cualquier equipo relacionado, debe planificar o realizar la instalación, la puesta en servicio, la operación y el mantenimiento de este equipo.
- Estas personas deben seguir todas las instrucciones de seguridad contenidas en este manual y/o definidas por normas locales.
- No seguir las instrucciones de seguridad puede resultar en riesgo de muerte y/o daños en el equipo.

**¡NOTA!**

Para los propósitos de este manual, personas calificadas son aquellas capacitadas de forma de estar aptas para:

1. Instalar, poner a tierra, energizar y operar el CFW50X, de acuerdo con este manual y los procedimientos legales de seguridad vigentes;
2. Usar el equipamiento de protección de acuerdo a las normas establecidas.
3. Dar primeros auxilios.

**¡PELIGRO!**

- Siempre desconecte la alimentación general antes de tocar cualquier componente eléctrico asociado al convertidor.
- Muchos componentes pueden permanecer cargados con altas tensiones y/o en movimiento (ventiladores), incluso después de que la entrada de alimentación CA haya sido desconectada o apagada.
- Espere por lo menos 10 minutos para garantizar la total descarga de los condensadores.
- Siempre conecte el equipo al tierra de protección (PE) en el punto adecuado para eso.

**¡ATENCIÓN!**

Las tarjetas electrónicas poseen componentes sensibles a descargas electrostáticas. No toque directamente los componentes o conectores. En caso necesario, utilice pulsera de puesta a tierra adecuada.

1.2 FUNCIONES DE SEGURIDAD IMPLEMENTADAS

Cuando está equipado con el módulo de función de seguridad CFW500-SFY2, el convertidor de frecuencia CFW50X está habilitado para realizar dos funciones de parada de seguridad estandarizadas:

1. Safe torque off (STO) de acuerdo con la IEC/EN 61800-5-2 o Stop category 0 de acuerdo con la IEC/EN 60204-1.
2. Safe stop 1 time controlled (SS1-t) de acuerdo con la IEC/EN 61800-5-2 o Stop category 1 de acuerdo con la IEC/EN 60204-1.

**¡ATENCIÓN!**

Incluso cuando la función de parada de seguridad está activa, pueden estar presentes, en el motor, niveles peligrosos de tensión. Antes de cualquier intervención en partes eléctricas, el sistema debe estar completamente desenergizado.

**¡ATENCIÓN!**

En circunstancias donde existen influencias externas como caídas de cargas suspendidas, pueden ser necesarias medidas adicionales como frenos mecánicos, por ejemplo, para prevenir cualquier riesgo. El análisis de riesgo debe ser realizado por el usuario final, con el fin de identificar y prevenir todos los riesgos y peligros posibles en la aplicación.

**¡NOTA!**

Esta función no debe ser utilizada como control de arranque y/o parada del motor.

**¡NOTA!**

La función de parada de seguridad tiene prioridad sobre todas las funciones del convertidor.

**¡NOTA!**

La seguridad completa del sistema depende de la certificación final donde el convertidor es aplicado. WEG no se responsabiliza por daños y/o pérdidas durante el uso o aplicación del convertidor. Por las mismas razones, WEG no se responsabiliza por aplicaciones basadas en las figuras y ejemplos descritos en este manual, las que son presentadas solamente para fines ilustrativos.

1.2.1 Safe Torque Off (STO)

La función de seguridad STO actúa impidiendo que el motor produzca torque, o sea, ninguna energía que cause torque quedará presente en el motor, cuando la función de seguridad STO esté activa. La diferencia entre la función de seguridad y una forma normal del motor es que la primera hace eso con niveles muy elevados de confiabilidad contra arranques inesperados del motor, incluso bajo una condición de falla, consulte el [Sección 1.3 DATOS DE SEGURIDAD en la página 40](#).

Una vez activada, la función de seguridad STO remueve la energía del circuito electrónico, haciendo que el motor gire libremente debido a la inercia de la carga. Vea la [Figura 1.1 en la página 39](#).



Figura 1.1: Comportamiento STO

1.2.2 Safe Stop 1 Time Controlled (SS1-t)

A diferencia de la función de seguridad STO, que, cuando activa, debe asegurarse de que no hay energía generadora de torque en la salida del convertidor de frecuencia, la función de seguridad SS1-t, cuando activa, inserta un tiempo de atraso controlado predefinido antes de ejecutar el STO para permitir que el convertidor de frecuencia imponga una rampa de deceleración al motor antes de retirar la energía generadora de torque. El SS1-t es especialmente útil en aplicaciones en las que las cargas inerciales deben ser desaceleradas antes de que el torque se quita del motor.

La [Figura 1.2 en la página 39](#) ilustra la actuación de la función SS1-t, donde se puede observar la actuación del tiempo controlado entre las barras verdes en la [Figura 1.2 en la página 39](#). El módulo de función de seguridad debe ser programado en un valor igual o superior a la capacidad del convertidor de desacelerar la carga; de lo contrario, el estado de "torque OFF" se puede alcanzar antes de la parada completa de la carga.

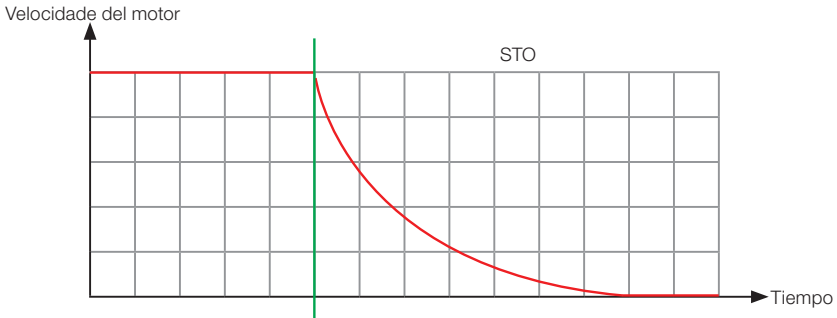

Figura 1.2: Comportamiento SS1-t

**¡NOTA!**

Conforme a la norma IEC/EN 61800-5-2, la ejecución de la rampa de desaceleración de la función de seguridad SS1-t puede fallar de forma no detectable, por lo tanto, esta función no debe ser utilizada en caso de que tal falla pueda causar una situación peligrosa en la aplicación final.

1.3 DATOS DE SEGURIDAD

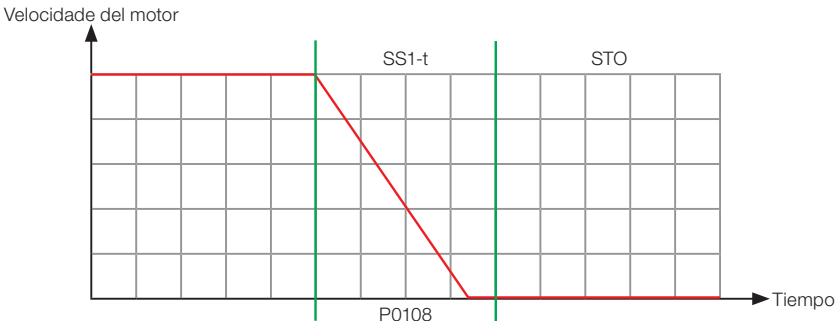
Los datos de seguridad para el convertidor de frecuencia CFW50X equipados con el CFW500-SFY2 se muestran en la [Tabla 1.1 en la página 40](#).

Tabla 1.1: Datos de seguridad

Funciones de seguridad	Safe torque off (STO), de acuerdo con la IEC 61800-5-2 Stop category 0, de acuerdo con la IEC 60204-1
	Safe stop 1 time controlled (SS1-t), de acuerdo con la IEC 61800-5-2 Stop category 1, de acuerdo con la IEC 60204-1
Categoría de seguridad	SIL 3, conforme IEC 61508 / IEC 62061 / IEC 61800-5-2 PL e, category 4, conforme EN ISO 13849-1
PFD _{avg}	$< 2,74 \times 10^{-4}$
PFH (1/h)	$< 3,11 \times 10^{-9}$
MTTF _d (y)	> 1600 años
DC _{avg}	ALTA (HIGH)
Intervalo de prueba (Proof test interval)	20 años (*)
Tiempo de reacción (Response/Reaction time)	< 100 ms
Pulsos de pruebas OSSD	Duración del pulso: < 1 ms Intervalo entre pulsos del mismo canal: > 8 ms Intervalo entre pulso de canales diferentes: > 4 ms
Señales en las entradas de seguridad	ON: 15 Vcc ... 30 Vcc
	OFF: < 2 V
Max. discrepancia de tiempo entre las señales de entrada	1 s
Fuente de alimentación	+24 Vcc ± 15 %, SELV type de acuerdo con la IEC 60950-1 o PELV type de acuerdo con la IEC 60204-1

(*) Esto significa que la vida útil del producto es de 20 años, o sea, después de este período el producto deberá ser sustituido.

**¡NOTA!**

Los accesorios del control del convertidor de frecuencia CFW50X proporcionan una fuente de alimentación de +24 Vcc (150 mA), que puede utilizarse para alimentar el CFW500-SFY2.

**¡NOTA!**

Más detalles sobre el convertidor CFW50X podrán ser encontrados en el manual de usuario, disponible para descargar en el sitio: www.weg.net.

1.4 DECLARATION Y CERTIFICACION

EU Declaration of Conformity



We, **WEG Drives & Controls - Automação Ltda**
(manufacturer)
Av. Prefeito Waldemar Grubba, 3000
89256-900 - Jaraguá do Sul - SC - Brazil
www.weg.net

WEG GERMANY GMBH
(Authorized Representative in the Europe Union)
Industriegebiet Türrich 3, Geigerstraße 7, 50169
Kerpen Türrich - North Rhine-Westphalia - Germany
Contact person: Wilmar Henning

declare that the products:

Type: Frequency inverter

Models: CFW50x, followed by A, B, C, D, E, F or G, followed by 01P0, 01P6, 02P6, 04P3, 06P1, 06P5, 07P0, 07P3, 09P6, 10P0, 12P2, 14P0, 16P0, 17P0, 19P4, 24P0, 28P0, 31P0, 33P0, 39P0, 47P0, 49P0, 56P0, 77P0, 88P0, 0105, 0142, 0145, 0180 or 0211, followed by S, B or T; followed by 2 or 4; followed by NB or DB, followed by 20, N1 or 66, followed by C2 or C3; may be followed by Y2, may be followed by DS; may be followed by Hxx, may be followed by Sxx, followed by G2. Equipped with the safety functions module CFW500-SFY2.

when installed, maintained and used on the applications they were designed for, and in compliance with the relevant installation standards and manufacturer's instructions, comply with the relevant European Union harmonization legislation where applicable.

Directives:

2006/42/EC Machinery Directive
2014/30/EU EMC Directive
2011/65/EU + 2015/863/EU RoHS Directive
2009/125/EC Ecodesign Directive

Standards:

EN 61800-5-2:2017 / IEC 61800-5-2:2016
EN 61800-5-1:2007+A:2017 / IEC 61800-5-1:2007
EN 61800-3:2018 / IEC 61800-3:2017
EN 62061:2005+AC:2010+A1:2013+A2:2015 /
IEC 62061:2005+A1:2012+A2:2015

FN ISO 13849-1:2015
IEC/EN 61508 Parts 1-7:2010
EN IEC 63000:2018
IEC 61800-9-2:2017

Notified body: TÜV Rheinland Industrie Service GmbH, Am Grauen Stein, 51105 Köln / Germany - Notified body #: NB 0035 - Certificate: 01/205/5723.01/20
This declaration of conformity is issued under the sole responsibility of the manufacturer.

Signed for and on behalf of WEG Drives & Controls - Automação Ltda

Adalberto José Rossa
Drives Development
Department Manager

Romy Cobía
Certification and Laboratory
Department Manager

Jaraguá do Sul, November 04th, 2022

UK Declaration of Conformity



Español

We, **WEG Drives & Controls - Automação Ltda**
(manufacturer)
Av. Prefeito Waldemar Crubba, 3000
89256-900 - Jaraguá do Sul - SC - Brazil
www.weg.net

declare that the products:

Models: CFW50x, followed by A, B, C, D, E, F or G, followed by 01P0, 01P6, 02P6, 04P3, 06P1, 06P5, 07P0, 07P3, 09P6, 10P0, 12P2, 14P0, 16P0, 17P0, 19P4, 24P0, 28P0, 31P0, 33P0, 39P0, 49P0, 56P0, 77P0, 88P0, 0105, 0142, 0145, 0180 or 0211 followed by S, B or T, followed by 2 or 4, followed by NB or DB, followed by 20, N1 or 66, followed by C2 or C3, may be followed by Y2, may be followed by DS, may be followed by Hxx, may be followed by Sxx, followed by G2. Equipped with the safety functions module CFW50n-SFY2.

Type: Frequency inverter

when installed, maintained and used on the applications they were designed for, and in compliance with the relevant installation standards and manufacturer's instructions, comply with the relevant UK Statutory Instruments and their amendments where applicable:

Regulations:

- | | | |
|---------|--|-------------------------------|
| N° 1597 | The supply of Machinery (Safety) regulations 2008 | BS EN ISO 13849-1:2015 |
| N° 1091 | The Electromagnetic Compatibility Regulations 2016 | BS EN 61608 Parts 1-7:2010 |
| N° 3032 | The Restriction of the Use of Hazardous Substances in Electrical and Electronic Equipment Regulations 2012 | BS EN 63000:2018 |
| N° 539 | The Ecodesign for Energy-Related Products and Energy Information (Amendment) (EU Exit) Regulations 2019 | BS EN 61800-9-2:2017 |
| | | Standards: |
| | | BS EN 61800-5-2:2017 |
| | | BS EN 61800-5-1:2007+A11:2021 |
| | | BS EN 61800-3:2018 |
| | | BS EN IEC 62061:2021 |

UK Approved body: TÜV Rheinland UK Ltd., Friars Gate (Third floor), 1011 Stratford Road, Shirley, Solihull B90 4BN, UK. Approved Body No.: 2571 – Certificate: 01205UJ5723 0022.

Signed for and on behalf of WEG Drives & Controls - Automação Ltda

Adalberto José Rossa
Drives Development
Department Manager

Remy Costa
Certification and Laboratory Department
Manager

Jaraguá do Sul, November 04th, 2022

EC Type-Examination Certificate



Product Safety
Functional
Safety

www.tuv.com
ID 0600000000

Reg.-No.: 01/205/5723.01/20

Product tested	Safety Functions "Safe Torque Off (STO)" and "Safe Stop 1 time controlled (SS1-t)" within Frequency Inverters	Certificate holder	WEG DRIVES & CONTROLS - AUTOMAÇÃO LTDA AV. Prof. Waldemar Grubba, 3000 89256-900 Jaraguá do Sul / SC Brazil
-----------------------	---	---------------------------	--

Type designation	Safety Module CFW500-SFY2 for the CFW5XX inverter series. Details see current "Revision List"
-------------------------	--

Codes and standards	EN 61800-5-2:2017 EN 61800-5-1:2007 + A1:2017 EN 61800-3:2018 EN ISO 13849-1:2015	EN 62061:2005 + AC:2010 + A1:2013 + A2:2015 IEC 61508 Parts 1-7:2010 EN 60204-1:2018 (in extracts)
----------------------------	--	--

Intended application	The safety functions STO and SS1-t comply with the requirements of the relevant standards (Cat. 4 / PL e acc. to EN ISO 13849-1, SIL 3 / SIL CL 3 acc. to EN 61800-5-2 / IEC 61508 / EN 62061) and can be used in applications up to Cat. 4 / PL e acc. to EN ISO 13849-1 and SIL 3 acc. to EN 62061 / IEC 61508.
-----------------------------	---

Specific requirements	The instructions of the associated Installation and Operating Manual shall be considered.
------------------------------	---

It is confirmed, that the product under test complies with the requirements for machines defined in Annex I of the EC Directive 2006/42/EC.

Valid until 2024-09-25

The issue of this certificate is based upon an examination, whose results are documented in Report No. 968/FSP 1886.01/20 dated 2020-03-30.
This certificate is valid only for products which are identical with the product tested.

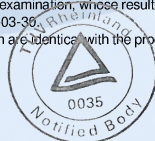

Köln, 2020-03-30

Notified Body for Machinery, NB 0035

Dipl.-Ing. Eberhard Frejno

www.fs-products.com
www.tuv.com

TÜVRheinland[®]
Precisely Right.

10222 12 12 E A4 © TÜV, TÜV and TÜV are registered trademarks. Utilisation and application requires prior approval.

TÜV Rheinland Industrie Service GmbH, Am Gauern Stein, 51105 Köln / Germany
Tel.: +49 221 893-2434, Fax: +49 221 893-1354, E-Mail: industrie_serve@ts.tuv.com

Español

UK Type-Examination Certificate



For UK Regulations SI 2008 No. 1597
The Supply of Machinery Regulations 2008

Reg.-No.: 01/205U/5723.00/22

Product tested	Safety Functions "Safe Torque Off (STO)" and "Safe Stop 1 time controlled (SS1-t)" within Frequency Inverters	Certificate holder	WEG DRIVES & CONTROLS - AUTOMAÇÃO LTDA AV. Prof. Waldemar Grubba, 3000 89256-900 Jaraguá do Sul / SC Brazil
Type designation	Safety Module CFW500-SFY2 for the CFW5XX inverter series. Details see current "Revision List"		
Codes and standards	EN 61800-5-2:2017 EN 61800-5-1:2007 + A1:2017 EN 61800-3:2018	EN ISO 13849-1:2015 EN 62061:2005 + AC:2010 + A1:2013 + A2:2015 EN 61508 Parts 1-7:2010	
Intended application	The safety functions STO and SS1-t comply with the requirements of the relevant standards (Cat. 4 / PL e acc. to EN ISO 13849-1, SIL 3 / SIL CL 3 acc. to EN 61800-5-2 / IEC 61508 / EN 62061) and can be used in applications up to Cat. 4 / PL e acc. to EN ISO 13849-1 and SIL 3 acc. to EN 62061 / IEC 61508. The product can be used in the application area of EN 60204-1:2018.		
Specific requirements	The instructions of the associated Installation and Operating Manual shall be considered.		

This product is in conformity with all requirements of SCHEDULE 2, PART 1 (Annex I) of SI 2008 No. 1597.
This Type-Examination certificate refers to an evaluation of the above mentioned product as stipulated in SCHEDULE 2, PART 9 (Annex IX) of SI 2008 No. 1597.

Valid until 2024-09-25

The issue of this certificate is based upon an examination, whose results are documented in Report No. 968/FSP 1886.03/22 dated 2022-10-05.

This certificate is valid only for products which are identical with the product tested.

Köln, 2022-10-12

TÜV Rheinland UK Ltd.

Approved Body for Machinery, No. 2571

Dipl.-Ing. Gebhard Bouwer

TÜV Rheinland UK Ltd., Fries Gate (Third Floor), 1011 Stratford Road, Shirley, Solihull B39 4BN / United Kingdom
Tel.: +44 (0)121 798 9400, E-Mail: UKCA@tuv.com, Web: https://www.tuv.com/united-kingdom/en/

www.fs-products.com
www.tuv.com

TÜVRheinland®
Precisely Right.

2 INSTALACIÓN

El convertidor debe ser instalado de acuerdo con las instrucciones del manual del usuario del CFW50X.

La [Tabla 2.1 en la página 45](#) presenta los datos técnicos relacionados al módulo de funciones de seguridad CFW500-SFY2.

Tabla 2.1: Datos técnicos del CFW500-SFY2

Dimensiones	Figura A.3 en la página 126 en el Apéndice A.
Masa	56 g.
Envoltorio	IP20.
Temperatura de Operación	-10 °C ... 40 °C.
Temperatura de Almacenamiento	-25 °C ... 60 °C.
Humedad Relativa del Aire	5 % ... 95 % sin condensación.
Altitud Máxima	Hasta 2000 m: condiciones nominales. De 2000 m a 4000 m: reducción de tensión de 1,1 % para cada 100 m por encima de 2000 m.
Grado de Contaminación	2 (de acuerdo con las normas EN 50178 y UL 508C), con contaminación no conductiva. La condensación no debe originar conducción a través de residuos acumulados.



¡ATENCIÓN!

Si el lugar de instalación no cumple los requisitos de grado de contaminación, el inversor debe tener una protección de entrada de al menos IP54 (según la norma IEC 60529), proporcionada por su carcasa o por un panel externo.

2.1 INSTALACIÓN DEL MÓDULO DE FUNCIONES DE SEGURIDAD

Para la correcta instalación del módulo de funciones de seguridad, ejecute los siguientes pasos:

Paso 1: Con el convertidor desenergizado, retire el conector jumper STO en la parte superior del convertidor, conforme la [Figura A.1 en la página 125 \(a\)](#).

Paso 2: Encaje el accesorio CFW500-SFY2 a ser instalado en la parte superior del convertidor, conforme es indicado en la [Figura A.1 en la página 125 \(b\)](#).

Paso 3: Siga el proceso de energización y puesta en funcionamiento descrito en el manual del usuario del CFW50X.

Paso 4: Verifique si el parámetro P0028 está indicando el valor 1 (P0028=1). Si esa información no fuera verdadera, verifique la conexión del módulo CFW500-SFY2 en la parte superior o en el interior del convertidor y repita los pasos de arriba.



¡NOTA!

O el conector jumper STO o el CFW500-SFY2 debe estar instalados en la parte superior o en el interior del convertidor de frecuencia. En caso contrario, el mensaje de error "F0086" aparecerá en el convertidor de frecuencia durante la activación.

2.2 CONEXIONES DEL MÓDULO DE FUNCIONES DE SEGURIDAD

Señales relacionadas con la seguridad deben estar conectadas al conector XC7 del CFW500-SFY2. La ubicación de este conector, así como la ubicación de las DIP switches S1 y S2, se indican en la [Figura 2.1 en la página 46](#).



Figura 2.1: Ubicación del conector XC7 y de las DIP switches S1 y S2

La [Tabla 2.2 en la página 46](#) describe las señales de seguridad en el conector XC7.

Tabla 2.2: Señales de seguridad en el XC7

Terminal	Nombre	Descripción
1	+24 Vcc	Fuente de +24 Vcc PELV/SELV.
2	SP1	Señal de seguridad de la entrada STO1.
3	STO1	Entrada de seguridad 1.
4	SP2	Señal de seguridad de la entrada STO2.
5	STO2	Entrada de seguridad 2.
6	GND	Referencia de la fuente de +24 Vcc PELV/SELV.

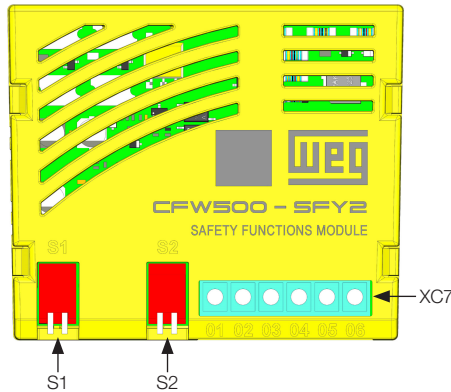

¡ATENCIÓN!

Las funciones de seguridad del CFW500-SFY2 se basan en una estructura de doble canal, que requiere dos entradas de seguridad independientes (STO1 y STO2). El uso de entradas de seguridad dependientes (por ejemplo, contactos de un mismo contactor) contraviene las instrucciones de este manual e invalida los datos de seguridad mostrados en la [Tabla 1.1 en la página 40](#).

La fuente de alimentación de +24 Vcc que se utilizará con el CFW500-SFY2 debe cumplir con la directiva de baja tensión 2006/95/EC, aplicando las especificaciones de la IEC/EN 61131-2, Programmable controllers - Part 2: Equipment requirements and tests, y debe cumplir una de las siguientes especificaciones:

- Safety extra-low voltage (SELV), de acuerdo con la norma IEC/EN 60950-1.
- Protected extra-low voltage (PELV), de acuerdo con la norma IEC/EN 60204-1.

¡NOTA!

Los accesorios del control del convertidor de frecuencia CFW50X proporcionan una fuente de alimentación de +24 Vcc (150 mA), que puede utilizarse para alimentar el CFW500-SFY2.

Para los cables del conector XC7, considerar:

- Longitud del decapado del cable: 6.0 mm (0.236 in).
- Calibre del alambre de 0,5 mm² (20 AWG) a 1,5 mm² (16 AWG).
- Torque máximo de apriete de 0,40 Nm (3,5 lbf.in).
- Pasar los cables separados de los circuitos restantes (potencia, control de 110 V / 220 Vca, etc.).

¡NOTA!

Las demás señales de control que no están relacionadas con la seguridad (entradas y salidas digitales / analógicas) se conectan a uno de los accesorios del control del convertidor de frecuencia. Los cables de estas señales de control no deben exceder los 30 m cuando el convertidor de frecuencia CFW50X esté equipado con el CFW500-SFY2.

¡NOTA!

En instalaciones donde existan contactores, se recomienda utilizar bloques supresores de sobretensión para los contactores, a fin de evitar la ocurrencia de disparos espurios de la falla F0160.

2.3 TIPOS DE INSTALACIÓN

Existen dos tipos de instalación, dependiendo del tipo de dispositivo de seguridad que solicita la función de seguridad:

- Instalación con contacto seco, se refiere a, todos los componentes que utilizan salidas al contacto electromecánico, como relés.
- Instalación con OSSD (Output Signal Switching Device), se refiere a, componentes con salida que contienen pulsos de prueba, como salidas de dispositivos de seguridad.

La [Figura 2.2 en la página 47](#) ilustra la instalación con contactos secos y la [Tabla 2.3 en la página 48](#) describe esta operación.



Figura 2.2: Instalación utilizando contacto seco

Tabla 2.3: Tabla verdadero/falso para operación con contacto seco

STO1 (contacto entre XC7:2 y XC7:3)	STO2 (contacto entre XC7:4 y XC7:5)	Función Parada de Seguridad	Comportamiento del Convertidor
Abierto	Abierto	Activada	El convertidor permanece en estado seguro. Los comandos de partida no se aceptan en ese estado. La HMI indica la alarma "A0160".
Abierto	Cerrado	Falla	El convertidor pasa al estado de falla "F0160" si tal estado permanece por más de 1 s. Para reiniciar la falla, los dos contactos deben tener el mismo estado lógico y el convertidor debe ser desenergizado y energizado nuevamente.
Cerrado	Abierto		
Cerrado	Cerrado	Desactivada	El convertidor de frecuencia funciona normalmente, aceptando órdenes de arranque.

La [Figura 2.3 en la página 48](#) ilustra la instalación con señales OSSD y la [Tabla 2.4 en la página 48](#) describe esta operación.

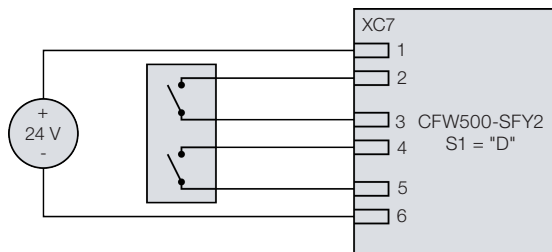

Figura 2.3: Instalación utilizando señales OSSD

Tabla 2.4: Tabla verdadero/falso para operación con señales OSSD

STO1 (tensión en XC7:3)	STO2 (tensión en XC7:5)	Función Parada de Seguridad	Comportamiento del Convertidor
0 V	0 V	Activada	El convertidor permanece en estado seguro. Los comandos de partida no se aceptan en ese estado. La HMI indica la alarma "A0160".
0 V	+24 V	Falla	El convertidor pasa al estado de falla "F0160" si tal estado permanece por más de 1s. Para reiniciar la falla, los dos contactos deben tener el mismo estado lógico y el convertidor debe ser desenergizado y energizado nuevamente.
+24 V	0 V		
+24 V	+24 V	Desactivada	El convertidor de frecuencia funciona normalmente, aceptando órdenes de arranque.

En instalaciones en el modo OSSD, es posible conectar múltiples convertidores de frecuencia a un solo actuador de seguridad, como se muestra en la [Figura 2.4 en la página 49](#). El número máximo de convertidores de frecuencia que se pueden conectar en paralelo está determinado por la capacidad de corriente del actuador de seguridad, con cada canal de entrada de seguridad consumiendo hasta 15 mA, es decir, 30 mA por convertidor de frecuencia.

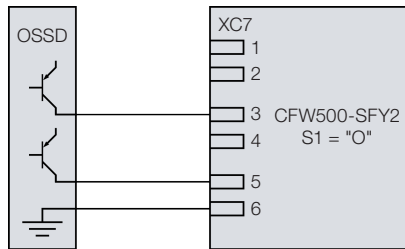

Figura 2.4: Instalación de múltiples convertidores de frecuencia (solo OSSD)



¡ATENCIÓN!

No se permite la conexión de varios convertidores de frecuencia con un actuador de contacto seco.

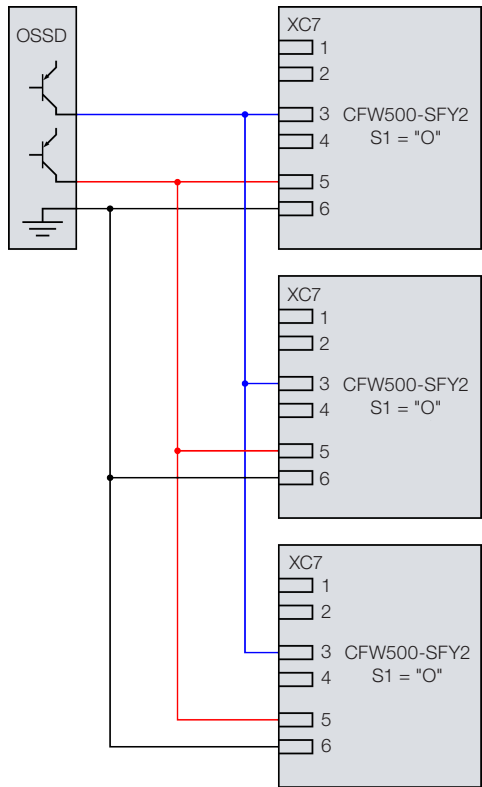
2.4 CONFIGURACIÓN DEL MÓDULO DE FUNCIONES DE SEGURIDAD

2.4.1 DIP Switches S1

Para configurar el módulo de función de seguridad CFW500-SFY2 para el tipo de instalación adecuado, los DIP switches S1 deben ajustarse antes de la energización, según la [Tabla 2.5 en la página 50](#), donde "D" significa "contactos secos" y "O" para "OSSD".



¡NOTA!

Ajustar las llaves DIP S1 para "D" o "O" luego de la energización no tiene efecto sobre el equipo.

Tabla 2.5: DIP switches S1

Configuración	Descripción
	<p>Ambas DIP switches ajustadas para "D" (contacto seco). Esta configuración debe elegirse cuando las señales de seguridad están controladas por contactos secos, como se muestra en la Figura 2.2 en la página 47.</p>
	<p>Una DIP switch ajustada para contacto seco (dry contact) y la otra ajustada para OSSD (Output Signal Switching Device). Ésta no es una combinación válida y resulta en un estado de falla (F0160) mostrado por el convertidor tras la energización. El convertidor no funcionará.</p>
	<p>Ambas DIP switches ajustadas para "D" OSSD (Output Signal Switching Device). Esta configuración debe elegirse cuando las señales de seguridad están controladas por una salida OSSD, como se muestra en la Figura 2.3 en la página 48.</p>
	<p>Ambas DIP switches ajustadas para "D" OSSD (Output Signal Switching Device). Esta configuración debe elegirse cuando las señales de seguridad están controladas por una salida OSSD, como se muestra en la Figura 2.3 en la página 48.</p>

2.4.2 DIP Switches S2

Las DIP switches S2 controlan o acceden al modo de programación de CFW500-SFY2, que permite seleccionar de cual función de seguridad se utilizará, así como una definición del tiempo de atraso en el caso de SS1-t. El procedimiento de programación se describe en detalles en la [Sección 3.3 PROGRAMACIÓN DE LA FUNCIÓN DE SEGURIDAD en la página 56](#).

Tabla 2.6: DIP switches S2

Configuración	Descripción
	<p>Ambas DIP switches ajustadas para ON. Esta configuración activa el estado de programación del CFW500-SFY2, mostrando la alarma A0162 en HMI. Para programar el módulo de funciones de seguridad, proceda de acuerdo con la Sección 3.3 PROGRAMACIÓN DE LA FUNCIÓN DE SEGURIDAD en la página 56.</p>
	<p>Una DIP ajustada para ON y otra para OFF. Ésta no es una combinación válida y la programación no se completará.</p>
	<p>Ambas DIP switches ajustadas para OFF. Esta configuración desactiva el estado de programación del CFW500-SFY2.</p>



¡NOTA!

Las llaves DIP S2 solamente deben ser ajustadas en la posición ON cuando el CFW500-SFY2 esté en estado seguro, lo que es indicado por la alarma A0160 en la HMI. Intentar entrar en el estado de programación, a partir de cualquier estado diferente del estado seguro, causará el estado de falla, lo que será indicado por la falla F0160 en la HMI.

3 PUESTA EN FUNCIONAMIENTO

3.1 PARÁMETROS RELACIONADOS AL MÓDULO DE FUNCIONES DE SEGURIDAD

Los parámetros del convertidor de frecuencia CFW50X que poseen relación directa con el módulo de funciones de seguridad CFW500-SFY2 son presentados:

Símbolos utilizados para describir las propiedades de los parámetros:

- ro: parámetro solamente de lectura.
- sy: parámetro solo visible en HMI cuando el módulo de seguridad está en el modo de programación.

P0028 - Módulo de Funciones de Seguridad

Rango de Valores:	0 = Conector Jumper STO 1 = CFW500-SFY2	Padrón: -
Propiedades:	ro	
Grupo de Acceso vía HMI:	<input type="text" value="READ"/>	

Descripción:

Identifica el módulo de funciones de seguridad que se encuentra conectado al convertidor. De acuerdo con la [Tabla 3.1 en la página 53](#).

Tabla 3.1: Identificación de lo módulo de funciones de seguridad

Nombre	Descripción	P0028
Conector jumper STO	Convertidor sin función de seguridad.	0
CFW500-SFY2	Convertidor está equipado con un módulo de funciones de seguridad capaz de realizar STO y SS1-t.	1



¡NOTA!

El conector jumper STO o el CFW500-SFY2 debe estar instalados en la parte superior o en el interior del convertidor de frecuencia. En caso contrario, el mensaje de error "F0086" aparecerá en el convertidor de frecuencia durante la activación.

P0106 - Tiempo 3ª Rampa

Rango de Valores:	0,1 a 999,0 s	Padrón: 5,0 s
Propiedades:		
Grupo de Acceso vía HMI:		

Descripción:

Define el tiempo de aceleración de cero a la velocidad máxima (P0134) o desaceleración de la velocidad máxima (P0134) a cero, cuando la 3ª Rampa está activa.



¡NOTA!

El convertidor de frecuencia usa la 3ª rampa para desacelerar el motor, cuando la función de seguridad SS1-t es solicitada. Por lo tanto, al usar el SS1-t, solamente modifique este parámetro durante la configuración del CFW500-SFY2.

P0108 - Tiempo SS1-t

Rango de Valores:	0 a 999 s	Padrón: 0 s
Propiedades:	sy	
Grupo de Acceso vía HMI:		

Descripción:

Define el tiempo de atraso de la función de seguridad SS1-t a ser programado en el módulo de funciones de seguridad. Si el valor del tiempo de retardo es 0 segundos, el módulo de funciones de seguridad se programa con la función de seguridad STO.



¡NOTA!

El parámetro P0108 es visible solamente en la HMI y, por lo tanto, sólo puede ser modificado cuando el módulo de funciones de seguridad esté en el modo de programación.

P0109 - Confirmación Tiempo SS1-t

Rango de Valores:	0 a 999 s	Padrón:
Propiedades:	ro, sy	
Grupo de Acceso vía HMI:		

Descripción:

Durante el procedimiento de programación del módulo de funciones de seguridad, indica el valor real del tiempo de retardo programado para la confirmación del usuario.



¡NOTA!

El parámetro P0109 es visible solamente en la HMI y, por lo tanto, sólo puede ser accedido cuando el módulo de funciones de seguridad esté en modo de programación.

3.2 PUESTA EN FUNCIONAMIENTO

La secuencia para poner en funcionamiento es:

- 1) Ejecute la instalación mecánica y eléctrica del convertidor de frecuencia de acuerdo con el manual del usuario CFW50X y el manual de seguridad.
- 2) Configure las DIP switches S1 de acuerdo con el tipo de señal de seguridad (contacto seco o OSSD) y las DIP switches S2 en la posición OFF.
- 3) Ajuste las entradas de seguridad para el estado seguro, es decir, los contactos abiertos o aplicar 0 V en las llaves STO1 y STO2.

- 4) Asegúrese de que el motor no está acoplado a la máquina o, si está acoplado, se puede girar en cualquier dirección sin ofrecer riesgos a las personas o daños a la máquina.
- 5) Energizar el convertidor.
- 6) Cargar la configuración de fábrica, a través de P0204, y verificar si el parámetro P0028 indica 1 (Módulo CFW500-SFY2).
- 7) Ajuste el convertidor de frecuencia de acuerdo con los requisitos de la aplicación.
- 8) En caso de que sea usada la función "Safe Stop 1 Time Controlled" (SS1-t), siga los pasos descritos en el [Sección 3.3 PROGRAMACIÓN DE LA FUNCIÓN DE SEGURIDAD en la página 56](#).
- 9) Ajustar las entradas de seguridad al estado operativo, es decir, cerrar los contactos o aplicar +24 V en las llaves STO1 y STO2 simultáneamente.
- 10) Verificar si el motor gira y para al apretar las teclas "I" y "O" de la HMI.
- 11) Accione el motor y ajuste las entradas de seguridad para el estado seguro, es decir, abrir los contactos o aplicar 0 V en las llaves STO1 y STO2 simultáneamente.
- 12) Verificar si el motor para de girar cuando el estado seguro es activado, indicando alarma A0160 en la HMI.
- 13) Ajustar las entradas de seguridad al estado operativo, es decir, cerrar los contactos o aplicar +24 V en las llaves STO1 y STO2 simultáneamente.
- 14) Verificar si el motor gira de nuevo al apretar las teclas "I" y "O" de la HMI.
- 15) Verificar todos los demás requisitos de la aplicación, a fin de asegurar el comportamiento deseado, así como la seguridad global del sistema en el cual el CFW50X está insertado.

**¡ATENCIÓN!**

Los pasos presentados son los mínimos necesarios para verificar la integridad de la función de seguridad del convertidor. Para verificación de la máquina o del sistema de trabajo y de la completa seguridad pueden ser necesarias otras medidas. El fabricante de la máquina es responsable por la verificación final y certificación de la seguridad del sistema que es aplicado al convertidor.

**¡ATENCIÓN!**

Siempre que la función de seguridad sea reconfigurada, es obligatorio realizar una prueba de verificación de su funcionamiento.

**¡NOTA!**

La activación simultánea de las entradas de seguridad significa que el tiempo entre la activación o la desactivación de las entradas debe ser inferior a 1 s. Este tiempo también es conocido como tiempo de discrepancia. Si el tiempo es superior a 1 s, la falla "F0160" será exhibida en la HMI del CFW50X. Para restablecer la falla es necesario ajustar las dos entradas (STO1 y STO2) para el mismo estado lógico y, en seguida, desenergizar y reenergizar el convertidor.

**¡NOTA!**

Pulsos de prueba presentes en las salidas OSSD son tolerados y no activan las funciones de seguridad, siempre que cumplan las siguientes especificaciones:

- Duración del pulso: < 1 ms.
- Intervalo entre pulsos en el mismo canal: > 8 ms.
- Intervalo entre pulsos en diferentes canales: > 4 ms.

3.3 PROGRAMACIÓN DE LA FUNCIÓN DE SEGURIDAD

El tiempo de atraso controlado de la función de seguridad SS1-t se utiliza para seleccionar qué función de seguridad está configurada en el módulo CFW500-SFY2. Si el tiempo de atraso está programado con 0 s, entonces el STO se selecciona, por otro lado, los valores de 1 s a 999 s configuran la función de seguridad SS1-t.

**¡NOTA!**

El valor predeterminado de fábrica para el tiempo de atraso controlado es 0 s, es decir, el módulo CFW500-SFY2 está preconfigurado con la función de seguridad STO.

El tiempo de atraso se programa ajustando las DIP switches S2 del módulo CFW500-SFY2 y definiendo los parámetros P0106, P0108 y P0109 vía HMI, de acuerdo con el siguiente procedimiento.

- 1) Ejecutar la secuencia de puesta en funcionamiento descrita en la [Sección 3.2 PUESTA EN FUNCIONAMIENTO](#) en la [página 54](#).
- 2) Asegúrese de que el convertidor está en estado seguro, es decir, las entradas de seguridad están desactivadas y la HMI indica la alarma "A0160".

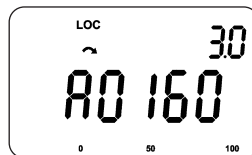

- 3) Ajustar ambas DIP switches S2 para la posición "ON". El convertidor debe indicar A0162, o sea, el módulo de funciones de seguridad entró en modo de programación.

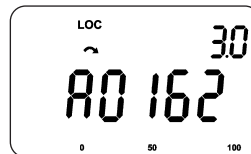
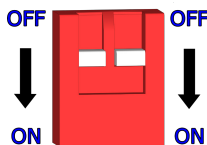

- 4) Configure el parámetro P0108 al valor del tiempo de retardo deseado, por ejemplo, 15 s, conforme la figura de abajo. Luego, presione la tecla "ENTER". En este punto, la luz de fondo de la pantalla comienza a parpadear y el usuario debe confirmar el valor programado mediante el parámetro P0109.

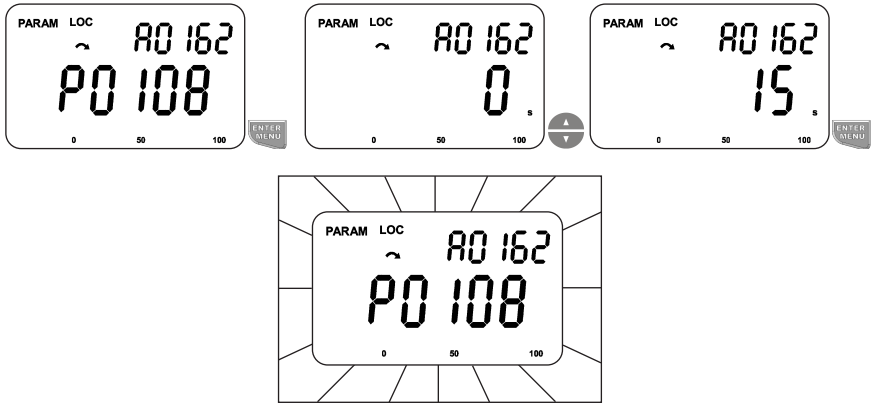

- 5) Para confirmar el valor programado, acceda al parámetro P0109 y verifique si el valor visualizado en P0109 es el mismo que el programado en P0108. Si los valores son los mismos, presione la tecla "ENTER" para confirmar. En este punto, la pantalla de nuevo debería dejar de parpadear. En el caso de valores diferentes para P0108 y P0109, el usuario debe presionar la tecla "ESC", que aborta el procedimiento de programación y dispara la falla F0160.

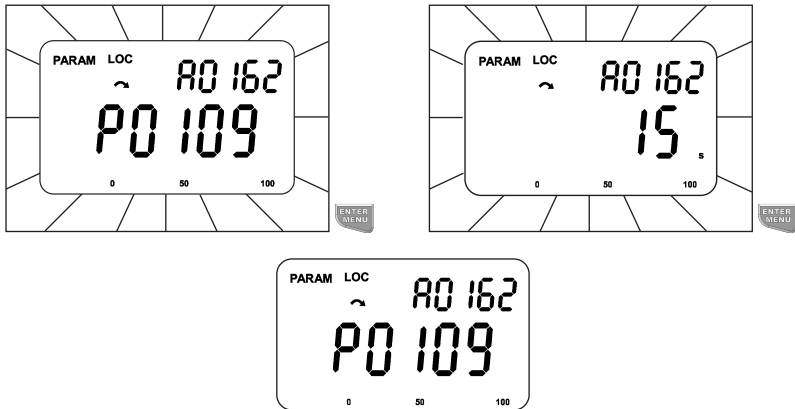
¡NOTA!

Si el procedimiento de programación del tiempo de atraso falla o se cancela, se conservará el último valor programado.



¡NOTA!

Si el procedimiento de programación permanece inactivo durante más de 2 minutos, el convertidor de frecuencia indicará falla F0160. Para restablecer esta falla, desenergice y reenergice el convertidor de frecuencia.

¡NOTA!

Si el usuario confirma un valor en P0109 diferente del programado en P0108, el convertidor de frecuencia accionará la falla F0160. Para restablecer esta falla, apague el convertidor de frecuencia y vuelva a encenderlo.

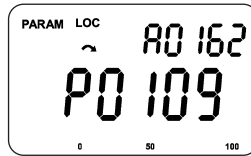
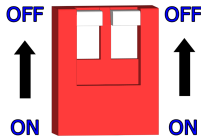
- 6) Después de programar y confirmar el valor del tiempo de retardo, el usuario debe devolver las DIP switches S2 a la posición "OFF". En este punto, el convertidor de frecuencia sale del modo de programación (A0162) y vuelve al estado seguro (A0160).



- 7) Ajuste el tiempo de desaceleración en P0106 parámetro para la rampa de deceleración que el convertidor de frecuencia se ejecutará durante una demanda de la función de seguridad SS1-t.



¡NOTA!

Para la función de seguridad STO, el parámetro P0106 es irrelevante para el rendimiento de la función de seguridad y este paso puede ser desconsiderado.

- 8) Ajuste las entradas de seguridad al estado de funcionamiento. El convertidor dejará de indicar la alarma A0160.
- 9) Presione la tecla "I" en la HMI para girar el motor.
- 10) Mientras el motor está girando, ajuste las entradas de seguridad de vuelta al estado seguro, verificando si el tiempo de atraso SS1-t (P0108) y la rampa de deceleración impuesta por el convertidor de frecuencia (P0106), si procede, para la aplicación. En caso contrario, repita este procedimiento de programación con los valores de tiempo apropiados.



¡NOTA!

Durante el tiempo de la función de seguridad SS1-t (tiempo de atraso), la alarma A0161 indicará en la HMI. Después de este tiempo de atraso, la HMI indicará la alarma A0160.



¡NOTA!

Ajustando el convertidor a la configuración de fábrica a través del parámetro P0204 no afecta a la programación del tiempo de atraso en el módulo de funciones de seguridad CFW500-SFY2.



¡NOTA!

La copia de parámetros a través del CFW500-MMF (módulo de memoria flash) no afecta a la programación del tiempo de atraso en el módulo de funciones de seguridad CFW500-SFY2.

4 MANTENIMIENTO Y DIAGNÓSTICO DE PROBLEMA

4.1 MANTENIMIENTO

El convertidor está equipado con varias funciones de autodiagnóstico y mensajes en la pantalla para ayudar al usuario a identificar anomalías y problemas con el convertidor o con la instalación.

El módulo de seguridad en especial, está equipado con un circuito de autodiagnóstico sumamente preciso, que garantiza que incluso bajo una falla, la seguridad no sea afectada. Las fallas en la instalación de seguridad son relatadas como "F0160", eso incluye algunas fallas de conexión de las señales de seguridad, errores en la configuración del módulo de función de seguridad y daños en los circuitos internos. Consulte la [Sección 4.2 ALARMAS Y FALLAS RELACIONADAS AL MÓDULO DE FUNCIONES DE SEGURIDAD en la página 60](#) para las causas más comunes de la falla F0160.

Si la falla "F0160" está siendo mostrada en la pantalla del convertidor y ninguna falla externa puede ser identificada, es posible que haya una falla interna en la tarjeta de seguridad. En este caso, el convertidor de frecuencia deberá ser retirado de operación y enviado a una asistencia técnica autorizada. Contacte al proveedor local WEG para obtener informaciones de cómo proceder.

**¡NOTA!**

Nunca intente reparar o permitir que una persona no autorizada por WEG repare el convertidor. La garantía de seguridad del producto se pierde automáticamente si se produce alguna infracción al producto.

**¡NOTA!**

No existen piezas de reposición para el módulo de funciones de seguridad CFW500-SFY2. En caso de daños, éste deberá ser sustituido por una unidad nueva.

**¡NOTA!**

Los circuitos de seguridad del CFW50X fueron concebidos de tal manera que ningún mantenimiento o prueba regulares son necesarios. El circuito realiza autopuebas a intervalos determinados y el convertidor informa si fue detectado algún problema.

**¡NOTA!**

Cuando una condición de falla del módulo de seguridad CFW500-SFY2 es detectada y la función SS1-t esté activa, el convertidor de frecuencia intenta ejecutar la desaceleración del motor (A0161) antes de la ejecución de la F0160 falta, similar a lo que ocurre cuando la función t-seguridad SS1 generalmente se activa mediante las entradas de seguridad.

**¡NOTA!**

La falla F0160 también representa un estado seguro sin torque.



¡NOTA!

En caso de mantenimiento de la máquina o del sistema, debe ser probada la total seguridad de la máquina, a fin de verificar la integridad de seguridad de la máquina o del sistema. Además de eso, en caso de una alteración o modificación, la validación de la función de seguridad debe ser repetida y documentada.



¡ATENCIÓN!

Si se produce una falla simultánea de dos o más IGBT del convertidor de frecuencia durante la activación de la función de seguridad, es posible que el accionamiento proporciona suficiente energía para causar una alineación magnética entre el rotor y los polos magnéticos internos del motor. Este movimiento depende del número de polos del motor y se limita a un ángulo máximo de 180 °. Aunque este evento es improbable, asegúrese de que esta posibilidad no cause daños a personas o daños a las máquinas.

4.2 ALARMAS Y FALLAS RELACIONADAS AL MÓDULO DE FUNCIONES DE SEGURIDAD

A0160 - Estado Seguro Activo

Descripción:

Indica al usuario que el estado seguro está activo.

Posibles Causas/Corrección:

- Actuación de las entradas de seguridad (STO1 y STO2).
- Señales de entrada de seguridad no instaladas.
- Señales de entrada de seguridad desenergizadas.

A0161 - Temporización SS1-t Activa

Descripción:

Indica al usuario que el módulo de funciones de seguridad está ejecutando la temporización de la función de seguridad SS1-t, mientras que el inversor desacelera el motor.

Posibles Causas/Corrección:

- Actuación de las entradas de seguridad con programación de la función de seguridad SS1-t.
- Falla detectada con la función de seguridad SS1-t configurada.

A0162 - Módulo de Funciones de Seguridad en Modo de Programación**Descripción:**

Indica al usuario que el módulo de funciones de seguridad está en modo de programación de las funciones de seguridad.

Posibles Causas/Corrección:

- Accionamiento de la programación de las DIP switches S2 del módulo de funciones de seguridad durante el estado seguro.

F0160 - Módulo de Funciones de Seguridad en Estado de Falla**Descripción:**

Indica al usuario que el módulo de funciones de seguridad entró en estado de falla.

Posibles Causas/Corrección:

- Instalación incorrecta de las entradas de seguridad.
- Discrepancia entre las entradas de seguridad (STO1 y STO2) mayor que 1 s.
- Configuración incorrecta del tipo de entrada de seguridad (contacto seco o OSSD) en las DIP switches S1.
- Módulo de seguridad con las DIP switches (S2) activados en el estado operativo.
- Programación incorrecta de la función de seguridad o *timeout* de programación (2 min).
- Avería en el circuito electrónico del módulo de funciones de seguridad.

F0161 - Falla de Comunicación con el Módulo de Funciones de Seguridad**Descripción:**

Indica al usuario que el convertidor perdió comunicación con el módulo de funciones de seguridad.

Posibles Causas/Corrección:

- Mal contacto entre el módulo de funciones de seguridad y el control del convertidor.
- Avería en el circuito electrónico del control del convertidor o del módulo de funciones de seguridad.

5 DESMONTAJE

Para la desactivación, la máquina o el sistema debe, preferentemente, ser desconectado de cualquier tipo de suministro de energía, si eso no fuera posible, todas las conexiones eléctricas, o sea, las conexiones de alimentación de la electrónica y la potencia del convertidor deben ser desconectadas antes de cualquier actividad de desactivación del convertidor.



¡PELIGRO!

Antes de la desactivación es necesario hacer un análisis de la seguridad de la máquina o del sistema, durante el desmontaje. Cargas suspendidas, frenos o partes rotativas pueden exigir energía para permanecer en estado seguro y la remoción de energía puede llevar a condiciones inseguras. Asegúrese de que la remoción de la energía pueda ser realizada de una forma segura.



¡PELIGRO!

Después de desconectar las conexiones de potencia del convertidor, éste podrá permanecer cargado con altas tensiones y/o en movimiento (ventiladores), incluso después de que la red de alimentación y la fuente de alimentación +24 Vcc sean desconectadas o apagadas. Espere por lo menos 10 minutos, a fin de garantizar la descarga completa de los componentes internos.



Manual de Segurança

Série: CFW50X

Idioma: Português

Documento: 10006503387 / 05

Data da Publicação: 09/2023

A informação abaixo descreve as revisões ocorridas neste manual.

Versão	Revisão do Manual	Revisão do Produto	Descrição
-	R00	A	Primeira edição.
-	R01	A	Revisão geral e inclusão do certificado TÜV para as funções de segurança.
-	R02	A	Revisão geral e inclusão do idioma mandarim.
-	R03	A	Revisão geral.
-	R04	A	Revisão geral.
-	R05	A	Atualização de declarações e certificações. Informações suplementares de instalação.

1 SEGURANÇA.....	67
1.1 INFORMAÇÕES GERAIS.....	67
1.2 FUNÇÕES DE SEGURANÇA IMPLEMENTADAS	68
1.2.1 Safe Torque Off (STO)	69
1.2.2 Safe Stop 1 Time Controlled (SS1-t)	69
1.3 DADOS DE SEGURANÇA	70
1.4 DECLARAÇÃO E CERTIFICAÇÃO	71
2 INSTALAÇÃO	75
2.1 INSTALAÇÃO DO MÓDULO DE FUNÇÕES DE SEGURANÇA.....	75
2.2 CONEXÕES DO MÓDULO DE FUNÇÕES DE SEGURANÇA.....	76
2.3 TIPOS DE INSTALAÇÃO	77
2.4 CONFIGURAÇÃO DO MÓDULO DE FUNÇÕES DE SEGURANÇA	80
2.4.1 Chaves DIP S1.....	80
2.4.2 Chaves DIP S2.....	81
3 COLOCAÇÃO EM FUNCIONAMENTO	83
3.1 PARÂMETROS RELACIONADOS AO MÓDULO DE FUNÇÕES DE SEGURANÇA	83
3.2 COLOCAÇÃO EM FUNCIONAMENTO.....	84
3.3 PROGRAMAÇÃO DA FUNÇÃO DE SEGURANÇA	86
4 MANUTENÇÃO E DIAGNÓSTICO DE PROBLEMA	89
4.1 MANUTENÇÃO	89
4.2 ALARMES E FALHAS RELACIONADOS AO MÓDULO DE FUNÇÕES DE SEGURANÇA	90
5 DESMONTAGEM	92

1 SEGURANÇA

1.1 INFORMAÇÕES GERAIS

**NOTA!**

Estas são as instruções originais.

Este manual de segurança apresenta as informações necessárias para instalar, configurar e operar o inversor de frequência com o módulo de funções de segurança CFW500-SFY2 e deve ser utilizado juntamente com os demais manuais do CFW50X. Consulte o manual do usuário e o manual de programação do CFW50X para mais detalhes na instalação, colocação em funcionamento, características técnicas, diagnósticos de problemas e programação. Todos os manuais estão disponíveis para download no site: www.weg.net.

**NOTA!**

Utilize o módulo de funções de segurança CFW500-SFY2 somente com inversores de frequência da linha CFW50X.

**PERIGO!**

- Somente pessoas com qualificação adequada e familiaridade com a função de segurança e o inversor CFW50X e equipamentos associados devem planejar ou implementar a instalação, partida, operação e manutenção deste equipamento.
- Estas pessoas devem seguir todas as instruções de segurança contidas neste manual e/ou definidas por normas locais.
- Não seguir as instruções de segurança pode resultar em risco de morte e/ou danos no equipamento.

**NOTA!**

Para os propósitos deste manual, pessoas qualificadas são aquelas treinadas de forma a estarem aptas para:

1. Instalar, aterrar, energizar e operar o CFW50X de acordo com este e demais manuais e os procedimentos legais de segurança vigentes.
2. Usar os equipamentos de proteção de acordo com as normas estabelecidas.
3. Prestar primeiros socorros.

**PERIGO!**

- Sempre desconecte a alimentação geral antes de tocar em qualquer componente elétrico associado ao inversor.
- Muitos componentes podem permanecer carregados com altas tensões e ou em movimento (ventiladores), mesmo depois que a entrada de alimentação for desconectada ou desligada.
- Aguarde pelo menos 10 minutos para garantir a total descarga dos capacitores.
- Sempre conecte o equipamento ao terra de proteção (PE) no ponto adequado para isto.

**ATENÇÃO!**

Os cartões eletrônicos possuem componentes sensíveis a descargas eletrostáticas. Não toque diretamente sobre componentes ou conectores. Caso necessário, utilize pulseira de aterramento adequada.

1.2 FUNÇÕES DE SEGURANÇA IMPLEMENTADAS

Quando equipado com o módulo de funções de segurança CFW500-SFY2, o inversor de frequência CFW50X está habilitado para executar duas funções de parada de segurança padronizadas:

1. Safe torque off (STO) de acordo com a IEC/EN 61800-5-2 ou Stop category 0 de acordo com a IEC/EN 60204-1.
2. Safe stop 1 time controlled (SS1-t) de acordo com a IEC/EN 61800-5-2 ou Stop category 1 de acordo com a IEC/EN 60204-1.

**ATENÇÃO!**

Mesmo quando a função de parada de segurança está ativa, níveis perigosos de tensão podem estar presentes no motor. Assim, antes de qualquer intervenção em partes elétricas, o sistema deve ser completamente desenergizado.

**ATENÇÃO!**

Em aplicações onde influências externas são relevantes (por exemplo, queda de cargas suspensas), medidas adicionais (uso de freio mecânico) podem ser necessárias para evitar riscos.

A análise de risco deve ser realizada pelo usuário final com o intuito de identificar e cobrir todos os riscos e perigos possíveis na aplicação.

**NOTA!**

As funções de segurança não devem ser utilizadas como controle de partida e/ou parada do motor.

**NOTA!**

As funções de segurança têm prioridade sobre todas as demais funções do inversor.

**NOTA!**

A segurança de todo o sistema depende da certificação final do equipamento onde o inversor é aplicado. A WEG não é responsável por danos e/ou perdas durante o uso ou aplicação do inversor. Por estas razões, a WEG não pode ser responsabilizada por aplicações baseadas nas figuras e exemplos descritos nesse manual, que são apresentadas apenas para fins ilustrativos.

1.2.1 Safe Torque Off (STO)

A função de segurança STO atua impedindo que o motor produza torque, ou seja, nenhuma energia que cause torque fica presente no motor quando a função de segurança STO está ativa. A diferença entre a função de segurança e uma forma usual de parada do motor é que no primeiro caso isso é feito com níveis muito elevados de confiabilidade contra partidas inesperadas do motor, mesmo sob uma condição de falha, consulte o [Seção 1.3 DADOS DE SEGURANÇA na página 70](#).

Uma vez ativada, a função de segurança STO remove a energia do circuito eletrônico, causando a parada do motor por inércia. Consulte a [Figura 1.1 na página 69](#).



Figura 1.1: Comportamento STO

1.2.2 Safe Stop 1 Time Controlled (SS1-t)

Diferentemente da função de segurança STO, que, quando ativa, deve garantir que não haja energia geradora de torque na saída do inversor de frequência, a função de segurança SS1-t, quando ativa, aguarda um tempo de atraso pré-definido antes de executar o STO a fim de permitir que o inversor de frequência imponha uma rampa de desaceleração ao motor antes de remover a energia geradora de torque. O SS1-t é especialmente útil em aplicações nas quais cargas inerciais precisam ser desaceleradas antes que o torque seja removido do motor.

A [Figura 1.2 na página 69](#) ilustra o comportamento da função de segurança SS1-t, onde é possível observar o tempo de atraso controlado entre as barras verdes na figura. O módulo de funções de segurança deve ser configurado com um valor de tempo igual ou maior à capacidade do inversor de frequência de desacelerar a carga; caso contrário, o estado de torque desabilitado pode ser alcançado antes da parada completa da carga.

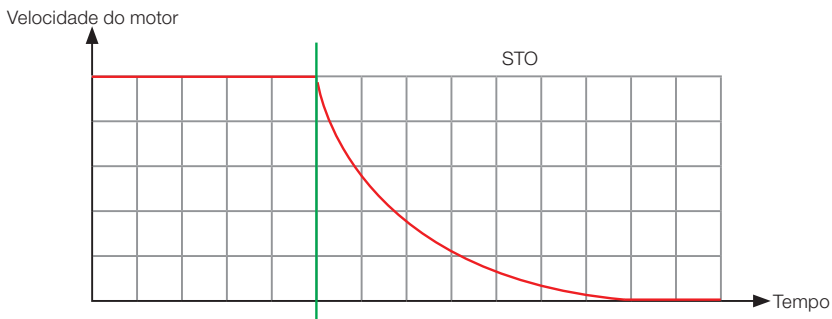

Figura 1.2: Comportamento SS1-t



NOTA!

Conforme norma IEC/EN 61800-5-2, a execução da rampa de desaceleração da função de segurança SS1-t pode falhar de forma não detectável, portanto, esta função não deve ser utilizada caso tal falha possa causar uma situação perigosa na aplicação final.

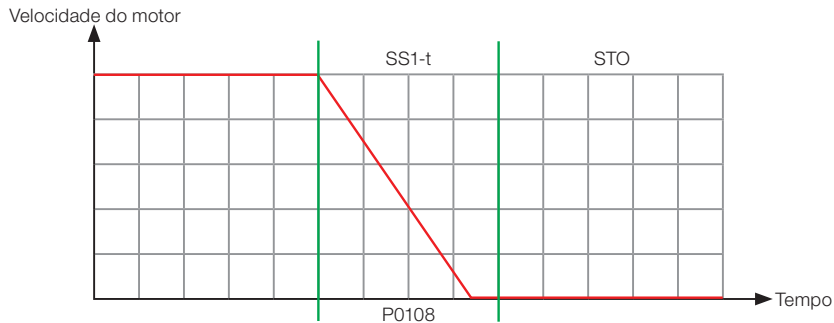
1.3 DADOS DE SEGURANÇA

Os dados de segurança para o inversor de frequência CFW50X equipados com o CFW500-SFY2 são apresentados na [Tabela 1.1 na página 70](#).

Tabela 1.1: Dados de segurança

Função de segurança	Safe torque off (STO), conforme IEC 61800-5-2 Stop category 0, conforme IEC 60204-1
	Safe stop 1 time controlled (SS1-t), conforme IEC 61800-5-2 Stop category 1, conforme IEC 60204-1
Categoria de segurança	SIL 3, conforme IEC 61508 / IEC 62061 / IEC 61800-5-2 PL e, category 4, conforme EN ISO 13849-1
PFD _{avg}	< 2,74 x 10 ⁻⁴
PFH(1/h)	< 3,11 x 10 ⁻⁹
MTTF _d (y)	> 1600 anos
DC _{avg}	ALTA (HIGH)
Intervalo de teste de prova (Proof test interval)	20 anos (*)
Tempo de reação (Response/Reaction time)	< 100 ms
Pulsos de testes OSSD	Duração do pulso: < 1 ms Intervalo entre pulsos do mesmo canal: > 8 ms Intervalo entre pulso de canais diferentes: > 4 ms
Sinais nas entradas de segurança	ON: 15 Vcc ... 30 Vcc
	OFF: < 2 V
Tempo de discrepância máximo entre os sinais de entrada	1 s
Fonte de alimentação	+24 Vcc ±15 %, SELV type de acordo com a IEC 60950-1 ou PELV type de acordo com a IEC 60204-1

(*) Isto significa que a vida útil do produto é 20 anos, ou seja, após esse período o produto deve ser substituído.



NOTA!

Os acessórios de controle do inversor de frequência CFW50X fornecem uma fonte de alimentação de +24 Vcc (150 mA), que pode ser utilizada para alimentar o CFW500-SFY2.



NOTA!

Mais informações sobre o inversor de frequência CFW50X podem ser encontradas no manual do usuário disponível no site WEG: www.weg.net.

1.4 DECLARAÇÃO E CERTIFICAÇÃO

EU Declaration of Conformity



We, **WEG Drives & Controls - Automação Ltda**
(manufacturer)
Av. Prefeito Waldemar Grubba, 3000
89256-900 - Jaraguá do Sul – SC – Brazil
www.weg.net

WEG GERMANY GMBH
(Authorized Representative in the Europe Union)
Industriegebiet Türnich 3, Geigerstraße 7, 50169
Kerpen Türnich - North Rhine-Westphalia - Germany
Contact person: Wilmar Henning

declare that the products:



Models: Type: Frequency inverter

CFW50x, followed by A, B, C, D, E, F or G, followed by 01P0, 01P6, 02P6, 04P3, 06P1, 06P5, 07P0, 07P3, 08P6, 10P0, 12P2, 14P0, 16P0, 17P0, 19P4, 24P0, 28P0, 31P0, 33P0, 39P0, 47P0, 49P0, 56P0, 77P0, 88P0, 0106, 0142, 0145, 0180 or 0211, followed by S, B or T, followed by 2 or 4, followed by NB or DB, followed by 20, N1 or 66, followed by C2 or C3, may be followed by Y2, may be followed by Hxx, may be followed by DS, may be followed by Sxx, followed by G2. Equipped with the safety functions module CFW500-SFY2.

when installed, maintained and used on the applications they were designed for, and in compliance with the relevant installation standards and manufacturer's instructions, comply with the relevant European Union harmonization legislation where applicable.

Directives:

2006/42/EC Machinery Directive
2014/30/EU EMC Directive
2011/65/EU + 2015/863/EU RoHS Directive
2009/125/EC Ecodesign Directive

Standards:

EN 61800-5-2:2017 / IEC 61800-5-2:2016 EN ISO 13849-1:2015
EN 61800-5-1:2007+A:2017 / IEC 61800-5-1:2007 IECEN 61508 Parts 1-7:2010
EN 61800-3:2018 / IEC 61800-3:2017 EN IEC 63000:2018
EN 62061:2005+AC:2010+A1:2013+A2:2015 / IEC 61800-9-2:2017
IEC 62061:2006+A1:2012+A2:2015

Notified body: TÜV Rheinland Industrie Service GmbH, Am Grauen Stein, 51105 Köln / Germany - Notified body #: NB 0035 – Certificate: 01/205/5723.01/20
This declaration of conformity is issued under the sole responsibility of the manufacturer.

Signed for and on behalf of: WEG Drives & Controls - Automação Ltda

Adalberto José Rossa
Drives Development
Department Manager

Ronny Costa
Certification and Laboratory
Department Manager

Jaraguá do Sul, November 04th, 2022

UK Declaration of Conformity



We, **WEG Drives & Controls - Automação Ltda**
(manufacturer)
Av. Prefeito Waldemar Grubba, 3000
89256-900 - Jaraguá do Sul – SC – Brazil
www.weg.net

WEG (UK) Ltd
(Authorized Representative in the UK)
Broad Ground Road, Lakeside, Redditch, Worcestershire
B99 8YP
Contact person: Patrick O'Neil

declare that the products:

Models:

CFW50x, followed by A, B, C, D, E, F or G, followed by 01P0, 01P6, 02P6, 04P3, 06P1, 06P5, 07P0, 07P3, 09P6, 10P0, 12P2, 14P0, 16P0, 17P0, 19P4, 24P0, 28P0, 31P0, 33P0, 39P0, 47P0, 56P0, 77P0, 88P0, 0105, 0142, 0145, 0180 or 0211 followed by S, B or T, followed by 2 or 4, followed by NB or DB, followed by 20, N1 or 66, followed by C2 or C3, may be followed by Y2, may be followed by DS₁, may be followed by Hxx, may be followed by Sxx, followed by G2. Equipped with the safety functions module CFW500-SFY2.

Type: Frequency inverter

when installed, maintained and used on the applications they were designed for, and in compliance with the relevant installation standards and manufacturer's instructions, comply with the relevant UK Statutory Instruments and their amendments where applicable.

Regulations:

N° 1597 The supply of Machinery (Safety) regulations 2008
N° 1091 The Electromagnetic Compatibility Regulations 2016
N° 3032 The Restriction of the Use of Hazardous Substances in Electrical and Electronic Equipment Regulations 2012
N° 533 The Ecodesign for Energy-Related Products and Energy Information (Amendment) (EU Exit) Regulations 2019

Standards:

BS EN 61800-5-2:2017
BS EN 61800-5-1:2007+A11:2021
BS EN 61800-3:2018
BS EN IEC 62061:2021
BS EN ISO 13849-1:2015
BS EN 61508 Parts 1-7:2010
BS EN 63000:2018
BS EN 61800-9-2:2017

UK Approved body: TÜV Rheinland UK Ltd., Friars Gate (Third floor), 1011 Stratford Road, Shirley, Solihull B90 4BN, UK. Approved Body No.: 2571 – Certificate: 01/205U/5723.00/22.

This declaration of conformity is issued under the sole responsibility of the manufacturer.

Signed for and on behalf of WEG'S Drives & Controls - Automação Ltda

Adalberto José Rossa
Drives Development
Department Manager

Rommy Costa
Certification and Laboratory Department
Manager

Jaraguá do Sul, November 04th, 2022

EC Type-Examination Certificate



Product Safety
Functional
Safety

www.tuv.com
ID 0600000000

Reg.-No.: 01/205/5723.01/20

Product tested	Safety Functions "Safe Torque Off (STO)" and "Safe Stop 1 time controlled (SS1-t)" within Frequency Inverters	Certificate holder	WEG DRIVES & CONTROLS - AUTOMAÇÃO LTDA AV. Prof. Waldemar Grubba, 3000 89256-900 Jaraguá do Sul / SC Brazil
-----------------------	---	---------------------------	--

Type designation	Safety Module CFW500-SFY2 for the CFW5XX inverter series. Details see current "Revision List"
-------------------------	--

Codes and standards	EN 61800-5-2:2017 EN 61800-5-1:2007 + A1:2017 EN 61800-3:2018 EN ISO 13849-1:2015	EN 62061:2005 + AC:2010 + A1:2013 + A2:2015 IEC 61508 Parts 1-7:2010 EN 60204-1:2018 (in extracts)
----------------------------	--	--

Intended application	The safety functions STO and SS1-t comply with the requirements of the relevant standards (Cat. 4 / PL e acc. to EN ISO 13849-1, SIL 3 / SIL CL 3 acc. to EN 61800-5-2 / IEC 61508 / EN 62061) and can be used in applications up to Cat. 4 / PL e acc. to EN ISO 13849-1 and SIL 3 acc. to EN 62061 / IEC 61508.
-----------------------------	---

Specific requirements	The instructions of the associated Installation and Operating Manual shall be considered.
------------------------------	---

It is confirmed, that the product under test complies with the requirements for machines defined in Annex I of the EC Directive 2006/42/EC.

Valid until 2024-09-25

The issue of this certificate is based upon an examination, whose results are documented in Report No. 968/FSP 1886.01/20 dated 2020-03-30.
This certificate is valid only for products which are identical with the product tested.

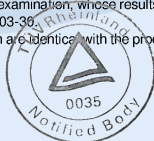

Köln, 2020-03-30

Notified Body for Machinery, NB 0035

Dipl.-Ing. Eberhard Frejno

10/222 12 12 E.44 © TÜV, TÜV and TÜV are registered trademarks. Utilisation and application requires prior approval.

TÜV Rheinland Industrie Service GmbH, Am Gauern Stein, 51105 Köln / Germany
Tel.: +49 221 896-2434, Fax: +49 221 896-1354, E-Mail: industrie.service@tuv.com

Português

www.fs-products.com
www.tuv.com

TÜVRheinland[®]
Precisely Right.

UK Type-Examination Certificate



For UK Regulations SI 2008 No. 1597
The Supply of Machinery Regulations 2008

Reg.-No.: 01/205U/5723.00/22

Product tested	Safety Functions "Safe Torque Off (STO)" and "Safe Stop 1 time controlled (SS1-t)" within Frequency Inverters	Certificate holder	WEG DRIVES & CONTROLS - AUTOMAÇÃO LTDA AV. Prof. Waldemar Grubba, 3000 89256-900 Jaraguá do Sul / SC Brazil
Type designation	Safety Module CFW500-SFY2 for the CFW5XX inverter series. Details see current "Revision List"		
Codes and standards	EN 61800-5-2:2017 EN 61800-5-1:2007 + A1:2017 EN 61800-3:2018	EN ISO 13849-1:2015 EN 62061:2005 + AC:2010 + A1:2013 + A2:2015 EN 61508 Parts 1-7:2010	
Intended application	The safety functions STO and SS1-t comply with the requirements of the relevant standards (Cat. 4 / PL e acc. to EN ISO 13849-1, SIL 3 / SIL CL 3 acc. to EN 61800-5-2 / IEC 61508 / EN 62061) and can be used in applications up to Cat. 4 / PL e acc. to EN ISO 13849-1 and SIL 3 acc. to EN 62061 / IEC 61508. The product can be used in the application area of EN 60204-1:2018.		
Specific requirements	The instructions of the associated Installation and Operating Manual shall be considered.		

This product is in conformity with all requirements of SCHEDULE 2, PART 1 (Annex I) of SI 2008 No. 1597.
This Type-Examination certificate refers to an evaluation of the above mentioned product as stipulated in SCHEDULE 2, PART 9 (Annex IX) of SI 2008 No. 1597.

Valid until 2024-09-25

The issue of this certificate is based upon an examination, whose results are documented in Report No. 968/FSP 1886.03/22 dated 2022-10-05.

This certificate is valid only for products which are identical with the product tested.

Köln, 2022-10-12

TÜV Rheinland UK Ltd.

Approved Body for Machinery, No. 2571

Dipl.-Ing. Gebhard Bouwer

TÜV Rheinland UK Ltd., Fries Gate (Third Floor), 1011 Stratford Road, Shirley, Solihull B90 4BN / United Kingdom
Tel.: +44 (0)121 796 9400, E-Mail: UKCA@tuv.com, Web: https://www.tuv.com/united-kingdom/en/

www.fs-products.com
www.tuv.com

 **TÜVRheinland®**
Precisely Right.

2 INSTALAÇÃO

O inversor deve ser instalado de acordo com as instruções do manual do usuário do CFW50X.

A [Tabela 2.1 na página 75](#) apresenta os dados técnicos relacionados ao módulo de funções de segurança CFW500-SFY2.

Tabela 2.1: Dados técnicos do CFW500-SFY2

Dimensões	Figura A.3 na página 126 no Apêndice A.
Massa	56 g.
Involúcro	IP20.
Temperatura de Operação	-10 °C ... 40 °C.
Temperatura de Armazenamento	-25 °C ... 60 °C.
Umidade Relativa do Ar	5 % ... 95 % sem condensação.
Altitude Máxima	Até 2000 m: condições nominais. De 2000 m a 4000 m: redução de tensão de 1,1 % para cada 100 m acima de 2000 m.
Grau de Poluição	2 (de acordo com as normas EN 50178 e UL 508C), com poluição não condutiva. A condensação não deve originar condução através de resíduos acumulados.



ATENÇÃO!

Se o local de instalação não atender aos requisitos de grau de poluição, o inversor deve ter uma proteção de ingresso de pelo menos IP54 (de acordo com a IEC 60529), fornecida ou pelo seu invólucro ou por um painel externo.

2.1 INSTALAÇÃO DO MÓDULO DE FUNÇÕES DE SEGURANÇA

Para a correta instalação do módulo de funções de segurança, execute os passos a seguir:

Passo 1: Com o inversor desenergizado, retire o conector jumper STO na parte superior do inversor conforme indicado na [Figura A.1 na página 125 \(a\)](#).

Passo 2: Encaixe o acessório CFW500-SFY2 a ser instalado na parte superior do inversor conforme indicado na [Figura A.1 na página 125 \(b\)](#).

Passo 3: Siga o processo de energização e colocação em funcionamento descrito no manual do usuário do CFW50X.

Passo 4: Verifique se o parâmetro P0028 está indicando o valor 1 (P0028 = 1). Se essa informação não for verdadeira, verifique a conexão do módulo CFW500-SFY2 na parte superior ou interna do inversor e repita os passos acima.



NOTA!

Ou o conector jumper STO ou o CFW500-SFY2 deve ser instalado na parte superior ou interna do inversor de frequência. Caso contrário, a mensagem de falha "F0086" será exibida pelo inversor de frequência durante a energização.

2.2 CONEXÕES DO MÓDULO DE FUNÇÕES DE SEGURANÇA

Os sinais relacionados à segurança devem ser conectados ao conector XC7 do CFW500-SFY2. A localização deste conector, bem como a localização das chaves DIP S1 e S2, é indicada na [Figura 2.1 na página 76](#).



Figura 2.1: Localização do conector XC7 e das chaves DIP S1 e S2

A [Tabela 2.2 na página 76](#) descreve os sinais de segurança no conector XC7.

Tabela 2.2: Sinais de segurança no XC7

Pino	Nome	Descrição
1	+24 Vcc	Fonte de +24 Vcc PELV/SELV.
2	SP1	Sinal de segurança para a entrada STO1.
3	STO1	Entrada de segurança 1.
4	SP2	Sinal de segurança para a entrada STO2.
5	STO2	Entrada de segurança 2.
6	GND	Referência da fonte de +24 Vcc PELV/SELV.

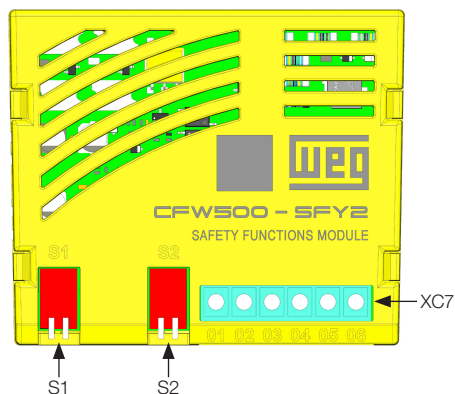

ATENÇÃO!

As funções de segurança do CFW500-SFY2 são baseadas em uma estrutura de duplo canal, a qual requer duas entradas de segurança independentes (STO1 e STO2). O uso de entradas de segurança dependentes (por exemplo, contatos do mesmo contator) está em desacordo com as instruções deste manual e invalida os dados de segurança apresentados na [Tabela 1.1 na página 70](#).

A fonte de alimentação de +24 Vcc a ser usada com o CFW500-SFY2 deve atender à diretiva de baixa tensão 2006/95/EC, aplicando as especificações da norma IEC/EN 61131-2, Programmable controllers - Part 2: Equipment requirements and tests, e deve atender a uma das seguintes especificações:

- Safety extra-low voltage (SELV), de acordo com a norma IEC/EN 60950-1.
- Protected extra-low voltage (PELV), de acordo com a norma IEC/EN 60204-1.

NOTA!

Os acessórios de controle do inversor de frequência CFW50X fornecem uma fonte de alimentação de +24 Vcc (150 mA), que pode ser utilizada para alimentar o CFW500-SFY2.

Para os cabos do conector XC7, considerar:

- Comprimento da decapagem do cabo: 6.0 mm (0.236 in).
- Bitola do cabo de 0,5 mm² (20 AWG) a 1,5 mm² (16 AWG).
- Torque máximo de aperto de 0,40 Nm (3,5 lbf.in).
- Passar os cabos separados dos circuitos restantes (potência, controle de 110 V / 220 Vca, etc.).

NOTA!

Os outros sinais de controle que não estão relacionados à segurança (entradas e saídas digitais / analógicas) são conectados a um dos acessórios de controle do inversor de frequência. Os cabos destes sinais de controle não devem exceder 30 m quando o inversor de frequência CFW50X estiver equipado com o CFW500-SFY2.

NOTA!

Em instalações com a presença de contatores, recomenda-se a utilização de blocos supressores de surto para os contatores, a fim de se evitar a ocorrência de disparos espúrios da falha F0160.

2.3 TIPOS DE INSTALAÇÃO

Existem dois tipos de instalação, dependendo do tipo de dispositivo de segurança que solicita a função de segurança:

- Instalação com dispositivo de contato seco, isto é, dispositivos que utilizam saídas com contato eletromecânico (por exemplo, relés convencionais).
- Instalação com OSSD (Output Signal Switching Device), isto é, dispositivos de estado sólido cujas saídas contêm pulsos de teste (por exemplo, cortina de luz).

A [Figura 2.2 na página 77](#) ilustra a instalação com contatos secos e a [Tabela 2.3 na página 78](#) descreve sua operação.



Figura 2.2: Instalação usando contato seco

Tabela 2.3: Tabela verdade para operação com contato seco

STO1 (Contato Entre XC7:2 e XC7:3)	STO2 (Contato Entre XC7:4 e XC7:5)	Função Parada de Segurança	Comportamento do Inversor
Aberto	Aberto	Ativada	O inversor permanece no estado seguro. Comandos de partida não são aceitos nesse estado. A HMI indica alarme "A0160".
Aberto	Fechado	Falha	O inversor vai para o estado de falha "F0160" se as entradas permanecerem assim por mais de 1 s. Para reiniciar a falha, os dois contatos STO1 e STO2 devem ter o mesmo estado lógico e o inversor deve ser desenergizado e energizado novamente.
Fechado	Aberto		
Fechado	Fechado	Desativada	O inversor de frequência opera normalmente, aceitando comandos de partida.

A Figura 2.3 na página 78 ilustra a instalação com sinais OSSD e a Tabela 2.4 na página 78 descreve sua operação.

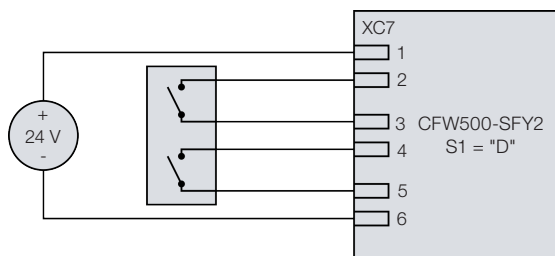

Figura 2.3: Instalação utilizando sinais OSSD

Tabela 2.4: Tabela verdade para operação com sinais OSSD

STO1 (Tensão em XC7:3)	STO2 (Tensão em XC7:5)	Função Parada de Segurança	Comportamento do inversor
0 V	0 V	Ativada	O inversor de frequência permanece no estado Seguro. Comandos de partida não são aceitos nesse estado. A HMI indica alarme "A0160".
0 V	+24 V	Falha	O inversor vai para o estado de falha "F0160" se as entradas permanecerem assim por mais de 1 s. Para reiniciar a falha, os dois contatos STO1 e STO2 devem ter o mesmo estado lógico e o inversor deve ser desenergizado e energizado novamente.
+24 V	0 V		
+24 V	+24 V	Desativada	O inversor de frequência opera normalmente, aceitando comandos de partida.

Em instalações no modo OSSD, é possível conectar vários inversores de frequência a um único atuador de segurança, conforme mostrado na Figura 2.4 na página 79. O número máximo de inversores de frequência que podem ser conectados em paralelo é determinado pela capacidade de corrente do atuador de segurança, sendo que cada canal de entrada de segurança consome até 15 mA, ou seja, 30 mA por inversor de frequência.

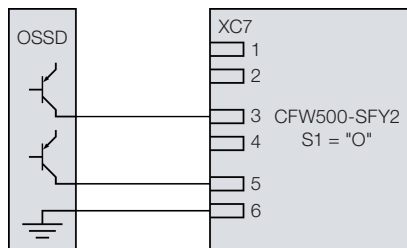

Figura 2.4: Instalação de múltiplos inversores de frequência (somente OSSD)



ATENÇÃO!

A conexão de múltiplos inversores de frequência com um atuador de contato seco não é permitida.

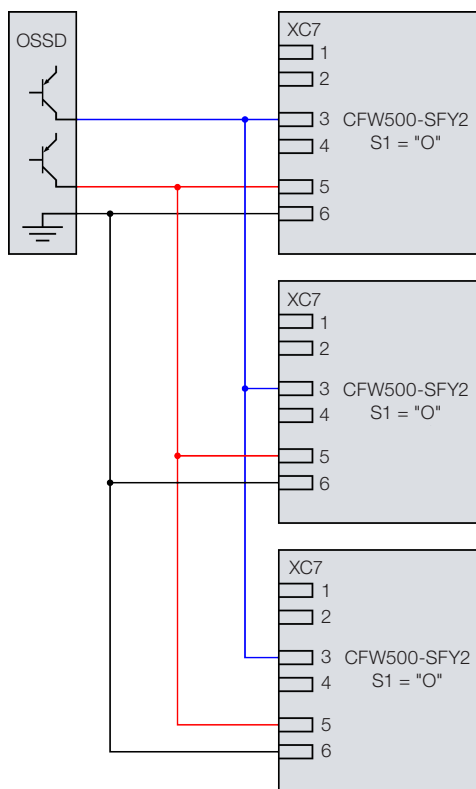
2.4 CONFIGURAÇÃO DO MÓDULO DE FUNÇÕES DE SEGURANÇA

2.4.1 Chaves DIP S1

Para configurar o módulo de funções de segurança CFW500-SFY2 para o tipo de instalação apropriado, as chaves DIP S1 devem ser ajustados antes da energização, conforme [Tabela 2.5 na página 80](#), onde "D" significa "contatos secos" e "O" para "OSSD".



NOTA!

Ajustar as as chaves DIP S1 para "D" ou "O" após a energização não tem efeito sobre o equipamento.

Tabela 2.5: Chaves DIP S1

Configuração	Descrição
	<p>Ambas as chaves DIP ajustadas para contato seco (dry contact). Esta configuração deve ser escolhida quando os sinais de segurança são comandados por contatos secos, por exemplo, relés, como apresentado na Figura 2.2 na página 77.</p>
	<p>Uma chave DIP ajustada para contato seco (dry contact) e a outra ajustada para OSSD (Output Signal Switching Device). Esta não é uma combinação válida e resulta em um estado de falha (F0160) mostrado pelo inversor após a energização. O inversor não irá funcionar.</p>
	<p>Ambas as chaves DIP ajustadas para OSSD (Output Signal Switching Device). Esta configuração deve ser escolhida quando os sinais de segurança são comandados por uma saída do tipo OSSD, como presente, por exemplo, em alguns tipos de relés de segurança, cortinas de luz, etc., como mostrado na Figura 2.3 na página 78.</p>

2.4.2 Chaves DIP S2

As chaves DIP S2 controlam o acesso ao modo de programação do CFW500-SFY2, que possibilita a seleção de qual função de segurança será usada, bem como a definição do tempo de atraso no caso de SS1-t. O procedimento de programação é descrito em detalhes na [Seção 3.3 PROGRAMAÇÃO DA FUNÇÃO DE SEGURANÇA na página 86](#).

Tabela 2.6: Chaves DIP S2

Configuração	Descrição
<p>OFF OFF ↓ ↓ ON ON</p>	<p>Ambas as chaves DIP ajustadas para ON. Esta configuração ativa o modo de programação do CFW500-SFY2, a HMI indica "A0162". Para programar o módulo de segurança, consulte a Seção 3.3 PROGRAMAÇÃO DA FUNÇÃO DE SEGURANÇA na página 86.</p>
<p>OFF OFF ↑ ↓ ON ON</p>	<p>Uma chave DIP ajustada para ON e outra para OFF. Esta não é uma combinação válida e a programação não será efetuada.</p>
<p>OFF OFF ↓ ↑ ON ON</p>	<p>Uma chave DIP ajustada para ON e outra para OFF. Esta não é uma combinação válida e a programação não será efetuada.</p>
<p>OFF OFF ↑ ↑ ON ON</p>	<p>Ambas as chaves DIP ajustadas para OFF. Esta configuração desativa o modo de programação do CFW500-SFY2.</p>



NOTA!

As chaves DIP S2 somente devem ser ajustadas na posição ON quando o CFW500-SFY2 estiver em estado seguro, o que é indicado pelo alarme A0160 na HMI. Tentar entrar no estado de programação a partir de qualquer estado diferente do estado seguro causará o estado de falha, que é indicado pela falha F0160 na HMI.

3 COLOCAÇÃO EM FUNCIONAMENTO

3.1 PARÂMETROS RELACIONADOS AO MÓDULO DE FUNÇÕES DE SEGURANÇA

Os parâmetros do inversor de frequência CFW50X que possuem relação direta com o módulo de funções de segurança CFW500-SFY2 são apresentadas a seguir.

Símbolos usados para descrever as propriedades dos parâmetros:

- ro: parâmetro somente de leitura.
- sy: parâmetro visível através da HMI se o produto possuir o módulo de funções de segurança instalado, durante o modo de programação.

P0028 - Módulo de Funções de Segurança

Faixa de Valores:	0 = Conector Jumper STO 1 = CFW500-SFY2	Padrão: -
Propriedades:	ro	
Grupo de Acesso via HMI:	<input type="text" value="READ"/>	

Descrição:

Identifica o módulo de funções de segurança conectado ao inversor, de acordo com a [Tabela 3.1 na página 83](#).

Tabela 3.1: Identificação do módulo de funções de segurança

Nome	Descrição	P0028
Conector jumper STO	Inversor de frequência sem função de segurança.	0
CFW500-SFY2	Inversor equipado com o módulo de funções de segurança capaz de executar STO e SS1-t.	1



NOTA!

Ou o conector jumper STO ou o CFW500-SFY2 deve ser instalado na parte superior ou interna do inversor de frequência. Caso contrário, a mensagem de falha "F0086" será exibida pelo inversor de frequência durante a energização.

P0106 - Tempo 3ª Rampa

Faixa de Valores:	0,1 a 999,0 s	Padrão: 5,0 s
Propriedades:		
Grupo de Acesso via HMI:		

Descrição:

Define o tempo de aceleração de zero à velocidade máxima (P0134) ou desaceleração da velocidade máxima (P0134) a zero quando a 3ª Rampa está ativa.

**NOTA!**

O inversor de frequência usa a 3ª Rampa para desacelerar o motor quando a função de segurança SS1-t é solicitada. Portanto, ao usar o SS1-t, somente modifique este parâmetro durante a configuração do CFW500-SFY2.

P0108 - Tempo SS1-t

Faixa de Valores: 0 a 999 s **Padrão:** 0 s

Propriedades: sy

Grupo de Acesso via HMI:

Descrição:

Define o tempo de atraso da função de segurança SS1-t a ser programado no módulo de funções de segurança. Se o tempo de atraso for 0 segundos, o módulo de funções de segurança está programado com a função de segurança STO.

**NOTA!**

O parâmetro P0108 é visível apenas na HMI e, portanto, só pode ser modificado quando o módulo de funções de segurança estiver no modo de programação.

P0109 - Confirmação Tempo SS1-t

Faixa de Valores: 0 a 999 s **Padrão:**

Propriedades: sy

Grupo de Acesso via HMI:

Descrição:

Durante a programação do módulo de funções de segurança, indica o valor programado de P0108 para a confirmação do usuário.

**NOTA!**

O parâmetro P0109 é visível apenas na HMI e, portanto, só pode ser acessado quando o módulo de funções de segurança estiver no modo de programação.

3.2 COLOCAÇÃO EM FUNCIONAMENTO

Sequência para a colocação em funcionamento:

- 1) Execute a instalação mecânica e elétrica do inversor de frequência de acordo com o manual do usuário e o manual de segurança do CFW50X.
- 2) Configure as chaves DIP S1 de acordo com o tipo de sinal de segurança (contato seco ou OSSD) e as chaves DIP S2 para OFF.

- 3) Ajuste as entradas de segurança para o estado seguro, isto é, abra os contatos ou aplique 0 V nas entradas de segurança STO1 e STO2.
- 4) Certifique-se de que o motor não está acoplado à máquina ou, se acoplado, o motor deve poder girar em qualquer direção sem oferecer riscos às pessoas ou danos à máquina.
- 5) Energize o inversor.
- 6) Carregue o padrão de fábrica do CFW50X parametrizando P0204 e verifique se o parâmetro P0028 indica 1 (CFW500-SFY2).
- 7) Programe o inversor de frequência de acordo com os requisitos da aplicação.
- 8) Caso a função de segurança SS1-t seja necessária, siga os passos descritos na [Seção 3.3 PROGRAMAÇÃO DA FUNÇÃO DE SEGURANÇA na página 86](#).
- 9) Ajuste as entradas de segurança para o estado operacional, isto é, feche os contatos ou aplique +24 V nas entradas de segurança STO1 e STO2 simultaneamente.
- 10) Verifique se o motor gira e para ao apertar as teclas "I" e "O" da HMI.
- 11) Acione o motor e ajuste as entradas de segurança para o estado seguro, isto é, abra os contatos ou aplique 0 V nas entradas STO1 e STO2 simultaneamente.
- 12) Verifique se o motor para quando o estado seguro é ativado, indicando o alarme "A0160" na HMI.
- 13) Ajuste as entradas de segurança para o estado operacional, isto é, feche os contatos ou aplique +24 V nas entradas STO1 e STO2 simultaneamente.
- 14) Verifique se o motor gira novamente usando as teclas "I" e "O" da HMI.
- 15) Verifique todos os demais requisitos da aplicação, com o intuito de assegurar o comportamento desejado, bem como a segurança global do sistema no qual o CFW50X está inserido.

**ATENÇÃO!**

Os passos apresentados são o mínimo necessário para verificar a integridade da função de segurança do inversor. Para verificação da máquina ou sistema e sua completa segurança, outras medidas podem ser necessárias. O fabricante da máquina é responsável pela verificação final e certificação da segurança da máquina ou sistema onde o inversor é aplicado.

**ATENÇÃO!**

Sempre que a função de segurança for reconfigurada, é obrigatório realizar um teste de verificação da operação.

**NOTA!**

Ativação simultânea das entradas de segurança significa que o tempo entre a ativação ou a desativação das entradas deve ser inferior a 1 s. Este tempo também é conhecido como tempo de discrepância. Se o tempo for superior a 1 s, a falha "F0160" será exibida na HMI do CFW50X. Para resetar a falha, é necessário ajustar as duas entradas (STO1 e STO2) para o mesmo estado lógico e, em seguida, desenergizar e reenergizar o inversor.

**NOTA!**

Os pulsos de teste presentes nas saídas OSSD são tolerados e não ativam as funções de segurança, desde que respeitem as seguintes especificações:

- Duração do pulso: < 1 ms.
- Intervalo entre pulsos no mesmo canal: > 8 ms.
- Intervalo entre pulsos em diferentes canais: > 4 ms.

3.3 PROGRAMAÇÃO DA FUNÇÃO DE SEGURANÇA

O tempo de atraso controlado da função de segurança SS1-t é usado para selecionar qual função de segurança é configurada no módulo CFW500-SFY2. Se o tempo de atraso for programado com 0 s, então o STO é selecionado. Por outro lado, valores de 1 s a 999 s configuram a função de segurança SS1-t.

**NOTA!**

O valor padrão de fábrica para o tempo de atraso controlado é 0 s, isto é, o módulo CFW500-SFY2 está pré-configurado com a função de segurança STO.

O tempo de atraso é programado ajustando as chaves DIP S2 do módulo CFW500-SFY2 e definindo os parâmetros P0106, P0108 e P0109 via HMI, de acordo com o procedimento abaixo.

- 1) Executar a sequência de colocação em funcionamento descrito na [Seção 3.2 COLOCAÇÃO EM FUNCIONAMENTO na página 84](#).
- 2) Certifique-se de que o inversor está no estado seguro, isto é, entradas de segurança estão desativadas e a HMI indica o alarme "A0160".

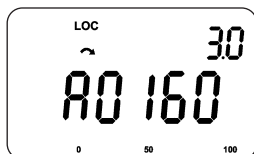

- 3) Ajustar as chaves DIP S2 para a posição "ON". O inversor deve indicar A0162, ou seja, o módulo de funções de segurança entrou no modo programação.

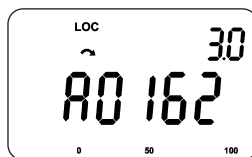
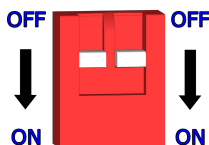

- 4) Ajuste o parâmetro P0108 para o valor desejado do tempo de atraso, por exemplo 15 s, conforme figura abaixo. Então, pressione "ENTER". Neste momento o display começa a piscar e o usuário deve confirmar o valor programado pelo parâmetro P0109.

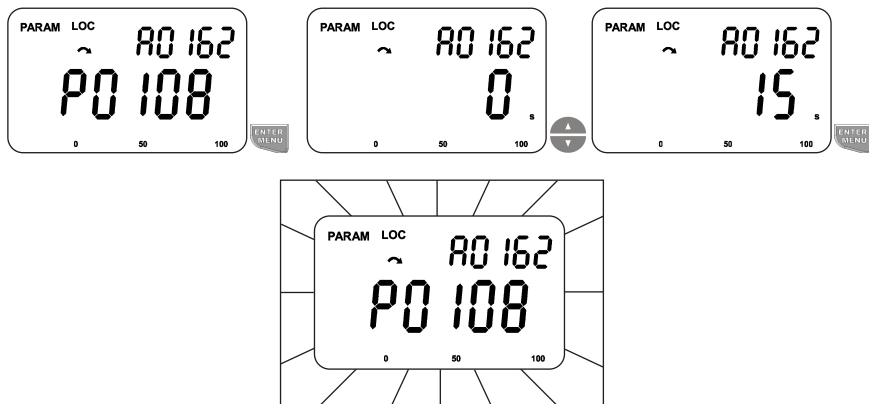

- 5) Para confirmar o valor programado, acesse o parâmetro P0109 e verifique se o valor mostrado no P0109 é o mesmo programado no P0108. Se os valores são iguais, pressione "ENTER" para confirmar. Neste momento, o display para de piscar. Em caso de valores diferentes para P0108 e P0109, o usuário deve pressionar "ESC", que cancela o procedimento e indicará "F0160".

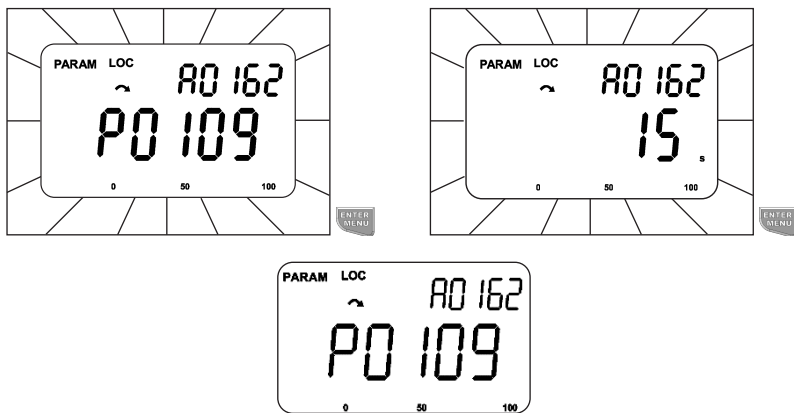
NOTA!

Se o procedimento da programação do tempo de atraso falhar ou for cancelado, o último valor programado será mantido.



NOTA!

Se o procedimento de programação permanecer inativo por mais de 2 minutos, o inversor de frequência indicará falha F0160. Para resetar esta falha, desenergize e re-energize o inversor de frequência.

**NOTA!**

Se o usuário confirmar um valor em P0109 diferente do programado em P0108, o inversor de frequência aciona a falha F0160. Para fazer o reset desta falha, desligue o inversor de frequência e volte a ligá-lo.

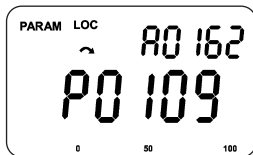
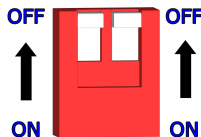
- 6) Após a programação e confirmação do valor de tempo de atraso, o usuário deve retornar as chaves DIP S2 para "OFF". Neste momento o inversor sai do estado de programação (A0162) e retorna ao estado seguro (A0160).



- 7) Ajuste o tempo de desaceleração no parâmetro P0106 para a rampa de desaceleração que o inversor irá executar durante uma solicitação da função de segurança SS1-t.

**NOTA!**

Para a função de segurança STO, o parâmetro P0106 é irrelevante para a performance da função de segurança e este passo pode ser desconsiderado.

- 8) Ajuste as entradas de segurança para o estado operacional. O inversor deixará de indicar o alarme A0160.
- 9) Pressione a tecla "I" na HMI para girar o motor.
- 10) Enquanto o motor estiver girando, ajuste as entradas de segurança de volta ao estado seguro, verificando se o tempo de atraso SS1-t (P0108) e a rampa de desaceleração imposta pelo inversor de frequência (P0106), se aplicáveis, são adequados para a aplicação. Caso contrário, repita este procedimento de programação com valores de tempo apropriados.

**NOTA!**

Durante o tempo da função de segurança SS1-t (tempo de atraso), o alarme A0161 será indicado na HMI. Após este tempo de atraso, a HMI indicará o alarme A0160.

**NOTA!**

Ajustando o inversor para o padrão de fábrica via parâmetro P0204 não afeta a programação do tempo de atraso no módulo de funções de segurança CFW500-SFY2.

**NOTA!**

A cópia de parâmetros via CFW500-MMF (módulo de memória flash) não afeta a programação do tempo de atraso no módulo de funções de segurança CFW500-SFY2.

4 MANUTENÇÃO E DIAGNÓSTICO DE PROBLEMA

4.1 MANUTENÇÃO

O inversor de frequência é equipado com várias funções de autodiagnóstico e mensagens na tela, para ajudar o usuário a identificar problemas com o inversor ou instalação.

O módulo de funções de segurança CFW500-SFY2, em particular, é equipado com um circuito de autodiagnóstico muito preciso, que garante altos níveis de segurança mesmo em condições de falha. As falhas relacionadas à segurança são reportadas como "F0160", que incluem erros de conexão dos sinais de segurança, erros na configuração do módulo de funções de segurança e danos nos circuitos internos. Consulte a [Seção 4.2 ALARMES E FALHAS RELACIONADOS AO MÓDULO DE FUNÇÕES DE SEGURANÇA](#) na página 90 para as causas mais comuns da falha F0160.

Se a falha "F0160" está sendo mostrada na tela do inversor e nenhuma falha externa pode ser identificada, é possível que exista uma falha interna no cartão de segurança. Neste caso, o inversor de frequência deve ser retirado de operação e então enviado a uma assistência técnica autorizada. Contate o fornecedor local WEG para obter informações de como proceder.

**NOTA!**

Nunca tente consertar ou permita que uma pessoa não autorizada pela WEG conserte o inversor. A garantia da segurança do produto é automaticamente perdida se ocorrer qualquer violação do produto.

**NOTA!**

Não há peças de reposição para o módulo de funções de segurança CFW500-SFY2. Em caso de danos, ele deve ser substituído por uma unidade nova.

**NOTA!**

Os circuitos de segurança funcional do CFW50X foram desenvolvidos de tal modo que nenhuma manutenção ou testes regulares são necessários. Os circuitos se verificam em intervalos regulares, informando ao usuário se algum problema for detectado.

**NOTA!**

Quando o módulo de funções de segurança CFW500-SFY2 detectar uma condição de falha e a função SS1-t estiver ativa, o inversor de frequência tenta executar a desaceleração do motor (A0161) antes da atuação da falha F0160, similarmente ao que ocorre quando a função de segurança SS1-t é normalmente ativada pelas entradas de segurança.

**NOTA!**

A falha F0160 também representa um estado seguro sem torque.



NOTA!

Em caso de manutenção da máquina ou sistema, toda a segurança deve ser retestada a fim de verificar a integridade da segurança da máquina ou sistema. Além disso, no caso de uma alteração ou modificação, a validação da função de segurança deve ser repetida e documentada.



ATENÇÃO!

Se ocorrer uma falha simultânea em dois ou mais IGBTs do inversor de frequência durante a ativação da função de segurança, é possível que o inversor de frequência forneça energia suficiente para causar um alinhamento magnético entre o rotor e os polos magnéticos internos do motor. Este movimento depende do número de polos do motor e é limitado a um máximo de 180 °. Embora esse evento seja improvável, certifique-se de que essa possibilidade não cause danos a pessoas ou danos a máquinas.

4.2 ALARMES E FALHAS RELACIONADOS AO MÓDULO DE FUNÇÕES DE SEGURANÇA

A0160 - Estado Seguro Ativo

Descrição:

Indica ao usuário que o estado seguro está ativo.

Possíveis Causas/Correção:

- Atuação dos sinais de entrada de segurança (STO1 e STO2).
- Sinais de entrada de segurança não instalados.
- Sinais de entrada de segurança desenergizados.

A0161 - Temporização SS1-t Ativa

Descrição:

Indica ao usuário que o módulo de funções de segurança está executando a temporização da função de segurança SS1-t, enquanto o inversor desacelera o motor.

Possíveis Causas/Correção:

- Atuação das entradas de segurança (STO1 e STO2) com a função de segurança SS1-t configurada.
- Falta detectada com a função de segurança SS1-t configurada.

A0162 - Módulo de Funções de Segurança em Modo de Programação**Descrição:**

Indica ao usuário que o módulo de funções de segurança está em modo de programação das funções de segurança.

Possíveis Causas/Correção:

- Acionamento da programação das chaves DIP S2 do módulo de funções de segurança durante o estado seguro.

F0160 - Módulo de Funções de Segurança em Estado de Falha**Descrição:**

Indica ao usuário que o módulo de funções de segurança entrou em estado de falha.

Possíveis Causas/Correção:

- Instalação incorreta do circuito das entradas de segurança.
- Discrepância entre as entradas de segurança (STO1 e STO2) maior que 1 s.
- Configuração incorreta do tipo de entrada de segurança (contato seco ou OSSD) nas chaves DIP S1.
- A programação das chaves DIP S2 do módulo de funções de segurança, está ativada no estado operacional.
- Programação incorreta da função de segurança ou *timeout* de programação (2 min).
- Circuito eletrônico do módulo de segurança danificado.

F0161 - Falha de Comunicação com Módulo de Funções de Segurança**Descrição:**

Indica ao usuário que o inversor perdeu comunicação com o módulo de funções de segurança.

Possíveis Causas/Correção:

- Mau contato entre o módulo de funções de segurança e o inversor.
- Circuito eletrônico do controle do inversor ou do módulo de funções de segurança está danificado.

5 DESMONTAGEM

Para a desativação da máquina ou sistema, deve-se preferencialmente desligar o equipamento. Caso não seja possível, todas as conexões de alimentação e controle do inversor deverão ser desenergizadas antes de qualquer intervenção no inversor.

**PERIGO!**

Antes da desativação, é necessário fazer uma análise da segurança da máquina ou do sistema durante a desmontagem. Cargas suspensas, freios ou partes rotativas podem exigir energia para permanecer em estado seguro e a remoção de energia pode levar a condições inseguras. Certifique-se que a remoção de energia pode ser realizada de uma forma segura.

**PERIGO!**

Após desligar as conexões do inversor alguns componentes podem permanecer carregados com altas tensões e/ou em movimento (ventiladores). Aguarde pelo menos 10 minutos para garantir a descarga total dos componentes.



安全手册

系列: CFW50X

语言: 英语

文件: 10006503387 / 05

日期: 09/2023

下表列举了所有对本手册所做的修订。

版本	手册修订	产品修订	描述
-	R00	A	第一版。
-	R01	A	出于安全目的，包含 TÜV 证书的一般重写。
-	R02	A	普通话语言添加和一般修订。
-	R03	A	一般修订。
-	R04	A	一般修订。
-	R05	A	声明和认证的更新。补充安装信息。

1 安全	97
1.1 基本资料	97
1.2 实施的安全功能	98
1.2.1 安全扭矩关闭 (STO)	98
1.2.2 时间控制的安全停止1 (SS1-t)	99
1.3 安全数据	100
1.4 声明和认证	101
2 安装	105
2.1 安全功能模块的安装	105
2.2 安全功能模块连接	106
2.3 安装类型	107
2.4 安全功能模块配置	110
2.4.1 指拨开关S1	110
2.4.2 指拨开关S2	111
3 调试	113
3.1 与安全功能模块相关的参数	113
3.1.1 参数	113
3.2 启动	115
3.3 配置安全功能	116
4 保养与故障排除	119
4.1 保养	119
4.2 与安全功能模块有关的警报和故障	120
5 停止运行	123

1 安全

1.1 基本资料



注意！
这些是原始说明的翻译。

本安全手册提供了安装、配置和操作CFW50X频率逆变器所需的信息，这些变频器配备了CFW500-sfy2安全功能模块，必须与CFW50X的其他手册一起使用。有关安装、启动、技术功能、故障排除和编程的更多详细信息，请参阅CFW50X的用户手册和编程手册。所有手册均可在此网站上下载：www.weg.net。



注意！
只能在CFW50X系列的WEG变频器上使用CFW500-SFY2安全功能模块。



危险！

- 只有具备相应资质、熟悉功能安全、熟悉CFW50X变频器及相关设备的人员，才能规划或执行本设备的安装、调试、操作和维护。
- 人员必须遵循本手册中描述的和/或当地标准定义的安全说明。
- 不遵守安全说明可能会有致死和/或设备损坏风险。



注意！
使用本手册的合格人员应经过培训应具有以下能力：

- 1.按照本手册和现行的安全法律程序安装、接地、通电和操作CFW50X。
- 2.按照相关标准使用防护设备。
- 3.实施急救。



危险！

- 触摸与变频器相关的所有电器部件之前，一定要切断主电源。
- 即使在交流电源输入断开或关闭后，许多组件仍可能带有高压和/或继续运行（风扇）。
- 至少等待 10 分钟，以保证电容器完全放电。
- 务必在适当的位置将设备连接到保护接地(PE)。



注意！
这种电子板的部件对静电放电很敏感。请勿直接触摸部件或连接器。
如有必要，请使用适当的接地带。

1.2 实施的安全功能

配备CFW500-SFY2安全功能模块时，CFW50X变频器能够执行两种标准化的安全停止功能：

1. 安全扭矩关闭（STO）（符合IEC/EN 61800-5-2）或停止类别0（符合IEC/EN 60204-1）。
2. 时间控制的安全停止1（SS1-t）（符合IEC / EN 61800-5-2）或停止类别1（符合IEC / EN 60204-1）。

**注意！**

即使启用了安全停止功能，电机中也可能存在危险电压电平。因此，在对电器部件进行任何干预之前，必须将系统完全断电。

**注意！**

在涉及外部影响（例如悬移载荷的下降）的应用中，可能需要采取其他措施（例如使用机械制动器）以防止任何危险。必须由终端用户进行风险分析，以便识别和涵盖应用程序中所有可能的危险和风险。

**注意！**

安全停止功能不应该用作启动和/或停止电机的控件。

**注意！**

安全停止功能优先于变频器的所有其他功能。

**注意！**

整个系统的安全性取决于使用变频器的设备的最终证书。在使用或应用变频器期间，WEG对损坏和/或损失不承担任何责任。由于这些原因，WEG不对以本手册中的图和示例为基础的应用负责，这些图和示例仅出于说明目的。

1.2.1 安全扭矩关闭（STO）

安全功能STO的作用是消除电机的扭矩，即STO和其他停止电动机的方法之间的区别在于，即使在故障情况下，STO也能以非常高的可靠性来防止电动机意外启动，请参阅第7页的1.3节“安全数据”。

启用后，安全功能STO将切断变频器输出电子电路的电源，使电动机惯性停止-参见第7页的图1.1。



图 1.1: STO操作

1.2.2 时间控制的安全停止1 (SS1-t)

当STO启用时，必须立即确保变频器输出处没有扭矩产生能量，SS1-t与STO不同，当安全功能SS1-t启用时，将在执行STO之前等待预定义的延迟时间，让变频器在消除产生转矩的能量之前对电机施加减速斜坡。SS1-t特别适用于需要在从电机上移除扭矩之前使惯性负载减速的应用场合。

第7页上的图1.2 说明了安全功能SS1-t的操作，可以观察到图中绿色条之间的受控延迟时间。安全功能模块配置的时间值应等于或大于变频器减速负荷的能力；否则，可能会在负载完全停止之前达到转矩断开状态。

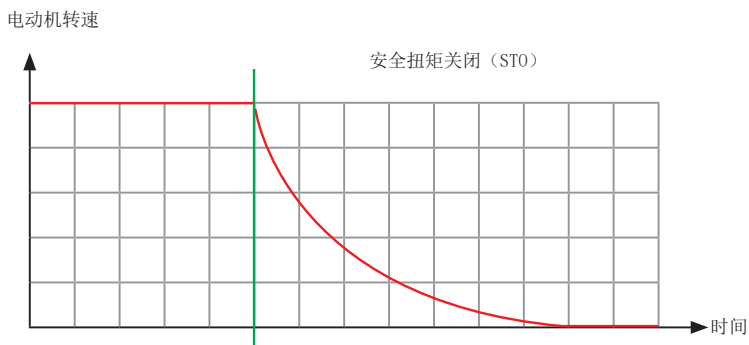

图 1.2: SS1-t 操作



注意!

根据IEC / EN 61800-5-2，安全功能SS1-t的减速斜坡可能会出现无法检测到的故障。因此，如果此故障可能在最终应用中导致危险情况，则不得使用此功能。

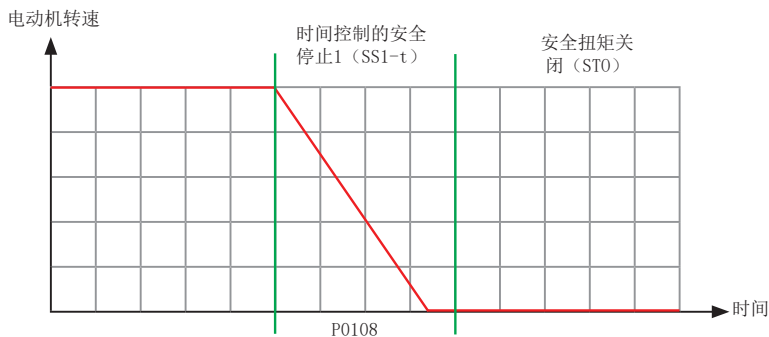
1.3 安全数据

装有CFW500-SFY2的CFW50X变频器的安全数据如表1.1第8页所示。

表 1.1: 安全数据

安全功能	符合IEC 61800-5-2的安全扭矩关闭 (STO) 符合IEC 60204-1的停止类别0
	符合IEC 61800-5-2的时间控制安全停止1 (SS1-t) 符合IEC 60204-1的停止类别1
安全类别	符合IEC 61508 / IEC 62061 / IEC 61800-5-2的SIL 3 符合EN ISO 13849-1的PL e (类别4)
PF _D 平均值	$< 2.74 \cdot 10^{-4}$
点特征直方图 (PFH) (1/h)	$< 3.11 \cdot 10^{-9}$
MTTF _D (年)	> 1600 年
DC平均值	HIGH
验证试验间隔时间	20年 ^(*)
响应/反应时间	< 100 毫秒
OSSD测试脉冲	脉冲持续时间: < 1 毫秒 同一通道上的脉冲间隔: > 8 毫秒 不同通道上的脉冲间隔: > 4 毫秒
安全输入信号	开: 15 直流电压... 30 直流电压
	关: < 2 伏特
安全输入信号之间的最大差异时间	1 秒
安全电源	+24 直流电压 $\pm 15\%$, 符合IEC 60950-1的安全超低电压 (SELV) 类型 或符合IEC 60204-1的保护超低电压 (PELV) 类型

(*) 这意味着产品的寿命或任务时间限制为20年，即产品应在20年后更换。



注意!

CFW50X变频器的控制附件提供+24 直流电压 电源 (150 mA)，可用于为CFW500-SFY2供电。



注意!

有关CFW50X变频器的基本参数可在用户手册中找到，可从以下网站下载：www.weg.net。

1.4 声明和认证

EU Declaration of Conformity



We, **WEG Drives & Controls - Automação Ltda**
(manufacturer)
Av. Prefeito Waldemar Grubba, 3000
89256-900 - Jaraguá do Sul – SC – Brazil
www.weg.net

WEG GERMANY GMBH
(Authorized Representative in the Europe Union)
Industriegebiet Türnich 3, Geigerstraße 7, 50169
Karpen Türnich - North Rhine-Westphalia - Germany
Contact person: Wilmar Henning

declare that the products:

Type: Frequency inverter

Models: CFW50x, followed by A, B, C, D, E, F or G, followed by 01P0, 01P6, 02P6, 04P3, 06P1, 06P5, 07P0, 07P3, 09P6, 10P0, 12P2, 14P0, 16P0, 17P0, 19P4, 24P0, 28P0, 31P0, 33P0, 39P0, 47P0, 49P0, 56P0, 77P0, 88P0, 0105, 0142, 0145, 0180 or 0211, followed by S, B or T, followed by 2 or 4, followed by NB or DB, followed by 20, N1 or 66, followed by C2 or C3, may be followed by Y2, may be followed by DS, may be followed by Hxx, may be followed by Sxx, followed by G2. Equipped with the safety functions module CFW500-SFY2.

when installed, maintained and used on the applications they were designed for, and in compliance with the relevant installation standards and manufacturer's instructions, comply with the relevant European Union harmonization legislation where applicable.

Directives:

2006/42/EC Machinery Directive
2014/30/EU EMC Directive
2011/65/EU + 2015/863/EU RoHS Directive
2009/125/EC Ecodesign Directive

Standards:

EN 61800-5-2:2017 / IEC 61800-5-2:2016
EN 61800-5-1:2007+A:2017 / IEC 61800-5-1:2007
EN 61800-3:2018 / IEC 61800-3:2017
EN 62061:2005+AC:2010+A1:2013+A2:2015 / IEC 62061:2005+A1:2012+A2:2015
EN ISO 13849-1:2015
IEC/EN 61508 Parts 1-7:2010
EN IEC 63000:2018
IEC 61800-9-2:2017

Notified body: TÜV Rheinland Industrie Service GmbH, Am Grauen Stein, 51105 Köln / Germany - Notified body #: NB 0035 – Certificate: 01/205/5723.01/20
This declaration of conformity is issued under the sole responsibility of the manufacturer.

Signed for and on behalf of WEG Drives & Controls - Automação Ltda

Adalberto José Rossa
Drives Development
Department Manager

Rommy Costa
Certification and Laboratory
Department Manager

Jaraguá do Sul, November 04th, 2022



UK Declaration of Conformity



We, **WEG Drives & Controls - Automação Ltda**
(manufacturer)
Av. Prefeito Waidemar Grubba, 3000
89256-900 - Jaraguá do Sul - SC - Brazil
www.weg.net

declare that the products:

Models: CFW50x followed by A, B, C, D, E, F or G followed by 01P0, 02P6, 04P3, 06P5, 07P0, 07P3, 09P6, 10P0, 12P2, 14P0, 16P0, 17P0, 19P4, 24P0, 28P0, 31P0, 33P0, 38P0, 47P0, 49P0, 55P0, 77P0, 88P0, 0105, 0142, 0145, 0180 or 0211 followed by S, B or T, followed by 2 or 4, followed by NB or DS followed by 20, N1 or 66, followed by C2 or C3, may be followed by Y2, may be followed by DS, may be followed by Hxx, may be followed by Sxx. Equipped with the safety functions module CFW500-SFV2.

Type: Frequency inverter

when installed, maintained and used on the applications they were designed for, and in compliance with the relevant installation standards and manufacturer's instructions, comply with the relevant UK Statutory Instruments and their amendments where applicable.

WEG (UK) Ltd
(Authorized Representative in the UK)
Broad Ground Road, Lakeside, Redditch, Worcestershire
B98 8YP
Contact person: Patrick O'Neil

Regulations:

- | | | |
|---------|--|----------------------------|
| N° 1597 | The supply of Machinery (Safety) regulations 2008 | BS EN ISO 13849-1:2015 |
| N° 1091 | The Electromagnetic Compatibility Regulations 2016 | BS EN 61608 Parts 1,7:2010 |
| N° 3032 | The Restriction of the Use of Hazardous Substances in Electrical and Electronic Equipment Regulations 2012 | BS EN 63000:2018 |
| N° 539 | The Ecodesign for Energy-Related Products and Energy Information (Amendment) (EU Exit) Regulations 2019 | BS EN 61800-9-2:2017 |

- | |
|-------------------------------|
| BS EN 61800-5-2:2017 |
| BS EN 61800-5-1:2007+A11:2021 |
| BS EN 61800-3:2018 |
| BS EN IEC 62061:2021 |

UK Approved body: TÜV Rheinland UK Ltd., Friars Gate (Third floor), 1011 Stratford Road, Shirley, Solihull B90 4BN, UK. Approved Body No.: 2571 – Certificate: 01/205U/5723.00/22.

Signed for and on behalf of WEG Drives & Controls - Automação Ltda

Remy Costa

Certification and Laboratory Department
Manager

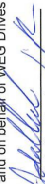
Adalberto José Rossa

Drives Development
Department Manager

Jaraguá do Sul, November 04th, 2022

EC Type-Examination Certificate



Product Safety
Functional
Safety

www.tuv.com
ID 0600000000

Reg.-No.: 01/205/5723.01/20

Product tested	Safety Functions "Safe Torque Off (STO)" and "Safe Stop 1 time controlled (SS1-t)" within Frequency Inverters	Certificate holder	WEG DRIVES & CONTROLS - AUTOMAÇÃO LTDA AV. Prof. Waldemar Grubba, 3000 89256-900 Jaraguá do Sul / SC Brazil
-----------------------	---	---------------------------	--

Type designation	Safety Module CFW500-SFY2 for the CFW5XX inverter series. Details see current "Revision List"
-------------------------	--

Codes and standards	EN 61800-5-2:2017 EN 61800-5-1:2007 + A1:2017 EN 61800-3:2018 EN ISO 13849-1:2015	EN 62061:2005 + AC:2010 + A1:2013 + A2:2015 IEC 61508 Parts 1-7:2010 EN 60204-1:2018 (in extracts)
----------------------------	--	--

Intended application	The safety functions STO and SS1-t comply with the requirements of the relevant standards (Cat. 4 / PL e acc. to EN ISO 13849-1, SIL 3 / SIL CL 3 acc. to EN 61800-5-2 / IEC 61508 / EN 62061) and can be used in applications up to Cat. 4 / PL e acc. to EN ISO 13849-1 and SIL 3 acc. to EN 62061 / IEC 61508.
-----------------------------	---

Specific requirements	The instructions of the associated Installation and Operating Manual shall be considered.
------------------------------	---

It is confirmed, that the product under test complies with the requirements for machines defined in Annex I of the EC Directive 2006/42/EC.

Valid until 2024-09-25

The issue of this certificate is based upon an examination, whose results are documented in Report No. 968/FSP 1886.01/20 dated 2020-03-30.
This certificate is valid only for products which are identical with the product tested.

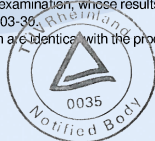

Köln, 2020-03-30

Notified Body for Machinery, NB 0035

Dipl.-Ing. Eberhard Frejno

10/22/12 12 E-A4 © TÜV, TÜEV and TÜV are registered trademarks. Utilisation and application requires prior approval.

TÜV Rheinland Industrie Service GmbH, Am Gassen Stein, E1105 Köln / Germany
Tel.: +49 221 886-2454, Fax: +49 221 886-1354, E-Mail: industrie.service@de.tuv.com

www.fs-products.com
www.tuv.com

TÜVRheinland[®]
Precisely Right.

UK Type-Examination Certificate



For UK Regulations SI 2008 No. 1597
The Supply of Machinery Regulations 2008

Reg.-No.: 01/205U/5723.00/22

Product tested	Safety Functions "Safe Torque Off (STO)" and "Safe Stop 1 time controlled (SS1-t)" within Frequency Inverters	Certificate holder	WEG DRIVES & CONTROLS - AUTOMAÇÃO LTDA AV. Prof. Waldemar Grubba, 3000 89256-900 Jaraguá do Sul / SC Brazil
Type designation	Safety Module CFW500-SFY2 for the CFW5XX inverter series. Details see current "Revision List"		
Codes and standards	EN 61800-5-2:2017 EN 61800-5-1:2007 + A1:2017 EN 61800-3:2018	EN ISO 13849-1:2015 EN 62061:2005 + AC:2010 + A1:2013 + A2:2015 EN 61508 Parts 1-7:2010	
Intended application	The safety functions STO and SS1-t comply with the requirements of the relevant standards (Cat. 4 / PL e acc. to EN ISO 13849-1, SIL 3 / SIL CL 3 acc. to EN 61800-5-2 / IEC 61508 / EN 62061) and can be used in applications up to Cat. 4 / PL e acc. to EN ISO 13849-1 and SIL 3 acc. to EN 62061 / IEC 61508. The product can be used in the application area of EN 60204-1:2018.		
Specific requirements	The instructions of the associated Installation and Operating Manual shall be considered.		

This product is in conformity with all requirements of SCHEDULE 2, PART 1 (Annex I) of SI 2008 No. 1597.
This Type-Examination certificate refers to an evaluation of the above mentioned product as stipulated in SCHEDULE 2, PART 9 (Annex IX) of SI 2008 No. 1597.

Valid until 2024-09-25

The issue of this certificate is based upon an examination, whose results are documented in Report No. 968/FSP 1886.03/22 dated 2022-10-05.
This certificate is valid only for products which are identical with the product tested.

Köln, 2022-10-12

TÜV Rheinland UK Ltd.

Approved Body for Machinery, No. 2571

Dipl.-Ing. Gebhard Bouwer

TÜV Rheinland UK Ltd., Fries Gate (Third Floor), 1011 Stratford Road, Shirley, Solihull B90 4BN / United Kingdom
Tel.: +44 (0)121 796 9400, E-Mail: UKCA@tuv.com, Web: https://www.tuv.com/en/uk/uk-ca/

2 安装

必须按照CFW50X用户手册的说明安装逆变器。

第11页上的表 2.1 介绍了与CFW500-SFY2安全功能模块有关的技术数据。

表 2.1: CFW500-SFY2技术数据

尺寸	附录A第11页上的图A. 3附录A。
质量	56 g。
附件	IP20。
运行温度	-10 ° C ... 40 ° C (14 ° F ... 104 ° F)。
储存温度	-25 ° C ... 60 ° C (-13 ° F ... 140 ° F)。
空气相对湿度:	5 % ... 95 % , 非凝结。
最大海拔	高达2000 m: 标称条件。 从2000 m至4000 m: 2000米以上每100米电压下降1.1 %。
污染等级	2 (根据EN 50178和UL 508C) , 具有非导电污染。 冷凝不会通过累积的残留物引起传导。



注意!

如果安装地点不符合污染程度要求, 变频器的防护等级必须至少达到IP54 (根据IEC 60529) , 由其外壳或外柜提供。

2.1 安全功能模块的安装

安全功能模块的正确安装步骤如下:

步骤1: CFW500断电后, 按照第11页 (a) 图A. 1卸下位于变频器顶部的STO跨接连接器。

步骤2: 根据第11页 (b) 中的图A. 1, 安装并按压要安装在变频器顶部的CFW500-SFY2。

步骤3: 请遵循CFW50X用户手册中所述的通电和启动程序。

步骤4: 检查参数P0028是否显示值“1” (P0028 = 1)。如果不是这种情况, 请检查逆变器的顶部或内部部的CFW500-SFY2模块的连接, 然后重复上述步骤。



注意!

STO 跳线连接器或 CFW500-SFY2 安全功能模块必须安装在变频器顶部或内部。否则, 变频器接通电源时将显示故障信息“ F0086”。

2.2 安全功能模块连接

与安全相关的信号必须连接到CFW500-SFY2的连接器XC7上。该连接器的位置以及DIP开关S1和S2的位置如第12页的图2.1所示。



图 2.1: 连接器XC7和DIP开关S1和S2的位置

第12页上的表2.2显示了连接器XC7上的安全信号。

表 2.2: XC7上的安全信号

插针	名称	描述
1	+24 直流电压	+24 直流电压 PELV / SELV的输入。
2	SP1	STO1输入的安全信号。
3	STO1	安全输入1。
4	SP2	STO2输入的安全信号。
5	STO2	安全输入2。
6	GND	+24 直流电压 PELV / SELV电源的参考。

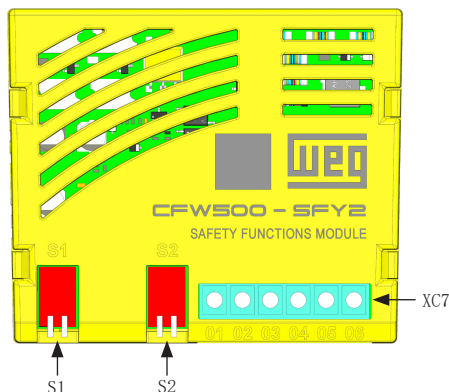

注意!

CFW500-SFY2 的安全功能基于双通道结构，需要两个独立的安全输入（STO1 和 STO2）。第 100 页表 1.1 中提供的安全信息因使用相关安全输入而失效，例如来自同一接触器的触点，这不符合本手册中的建议。

与CFW500-SFY2一起使用的+24 直流电压电源必须符合低压指令2006/95 / EC（适用IEC / EN 61131-2，可编程控制器，第2部分）：“设备要求和测试”，并且必须符合以下规范之一：

- 符合IEC/EN60950-1的安全超低电压（SELV）。
- 符合IEC/EN60204-1的保护超低电压。

注意!

CFW50X变频器的控制附件提供+24 直流电压 电源 (150 mA)，可用于为 CFW500-SFY2供电。

对于XC7布线，请考虑以下因素：

- 剥线长度: 6.0毫米 (0.236英寸)
- 线规范范围从0.5mm² (20 AWG) 到1.5mm² (16 AWG)。
- 最大拧紧扭矩为0.40 Nm (3.5 lbf.in)。
- 将电缆与其余电路分开 (电源, 110 V / 220 V控制等)。

注意!

与安全无关的其他控制信号 (数字/模拟输入和输出) 连接到变频器的控件。当 CFW50X变频器装有CFW500-SFY2时，用于这些控制信号的电缆不得超过30 m。

笔记!

为避免在存在接触器的安装地点发生故障 F0160 的错误跳闸，建议为接触器安装电涌抑制器块。

2.3 安装类型

根据需要安全功能的安全设备的类型，有两种安装类型：

- 使用干接点设备 (即具有机电输出的设备 (例如常规继电器)) 进行安装。
- 使用输出信号转换设备 (OSSD) (即具有包含测试脉冲的输出 (例如光幕) 的固态设备) 进行安装。

第13页上的图2.2 介绍了干接点的安装，第13页上的表2.3 介绍了其操作方式。



图 2.2: 使用干接点的安装

表 2.3: 干接点操作的真值表

ST01 (XC7: 2和 XC7: 3之间的 接触)	ST02 (XC7: 4和 XC7: 5之间的 接触)	安全停止 功能	变频器操作
打开	打开	启用	变频器保持在安全状态。在此状态下不接受启动命令。人机界面显示屏显示警报A0160。
打开	关闭	故障	如果此类输入配置持续时间超过1 s, 则变频器将跳至故障F0160。要重置此故障, ST01和ST02必须处于相同的逻辑状态, 必须对变频器断电后重新通电。
关闭	打开		
关闭	关闭	停机	变频器正常运行, 接受启动命令。

第14 页的图2. 3介绍了OSSD的安装, 第14页的表2.4 介绍了其操作方式。

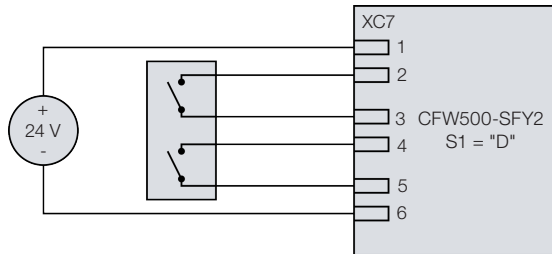

图 2.3: 使用OSSD信号进行安装

表 2.4: OSSD信号的真值表

ST01 (XC7: 3上的 电压)	ST02 (XC7: 5上的 电压)	安全停止 功能	变频器操作
0 V	0 V	启用	变频器保持在安全状态。在此状态下不接受启动命令。人机界面显示屏显示警报A0160。
0 V	+24 V	故障	如果此类输入配置持续时间超过1 s, 则变频器将跳至故障F0160。要重置此故障, ST01和ST02必须处于相同的逻辑状态, 必须对变频器断电后重新通电。
+24 V	0 V		
+24 V	+24 V	停机	变频器正常运行, 接受启动命令。

如图 2.4 所示, 在 OSSD 设置中, 可以将多个变频器连接到单个安全执行器。安全执行器的电流容量决定了可以并联的变频器的最大数量, 每个安全输入通道最多使用 15 mA, 或每个变频器 30 mA。

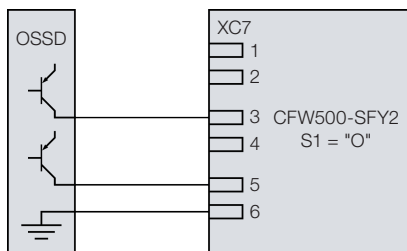

图 2.4: 安装多台变频器 (仅限 OSSD)



注意!
不允许将多个变频器与一个干接点执行器连接。

2.4 安全功能模块配置

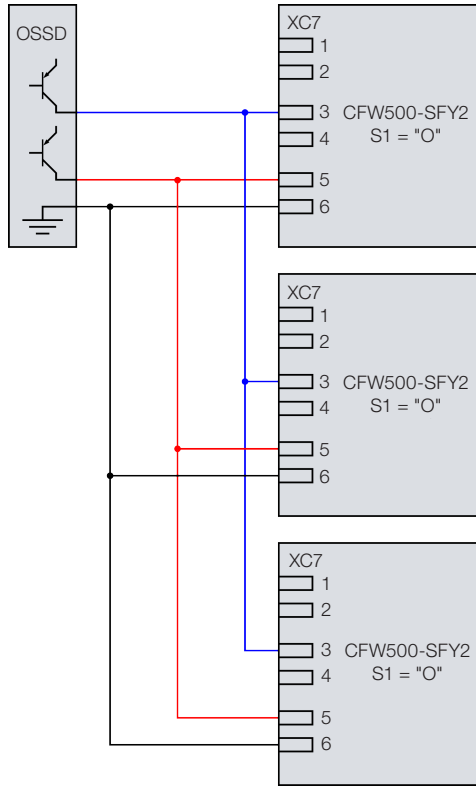
2.4.1 指拨开关S1

为了配置CFW500-SFY2安全功能模块以进行适当的安装，DIP开关S1必须根据第15页的表2.5在通电前设置好，（其中“D”代表“干接点”和“O”代表“OSSD”）。



注意!

通电后将DIP开关S1设置为“D”或“O”对设备没有影响。

表 2.5: DIP开关S1

配置	描述
<p>The diagram shows a red DIP switch module with two switches. Both switches are in the 'D' position, indicated by upward-pointing arrows. Labels 'D' and 'O' are placed around the switches to identify the positions.</p>	<p>两个DIP开关均设置为“D”（干接点）。 当通过干接点控制安全信号时（如第15页的图2.2所示），必须选择此配置。</p>
<p>The diagram shows a red DIP switch module. The left switch is in the 'D' position (upward arrow) and the right switch is in the 'O' position (downward arrow). Labels 'D' and 'O' are placed around the switches.</p>	<p>一个DIP开关设置为“D”（干接点），另一个设置为“O”（OSSD）。</p>
<p>The diagram shows a red DIP switch module. The left switch is in the 'O' position (downward arrow) and the right switch is in the 'D' position (upward arrow). Labels 'D' and 'O' are placed around the switches.</p>	<p>这不是有效的组合，会导致故障状态（F0160），通电后会显示在变频器上。变频器将无法工作。</p>
<p>The diagram shows a red DIP switch module with two switches. Both switches are in the 'O' position, indicated by downward-pointing arrows. Labels 'D' and 'O' are placed around the switches.</p>	<p>两个DIP开关均设置为“O”（OSSD）。 当安全信号由OSSD输出控制（如第15页的图2.3所示）时，必须选择此配置。</p>

2.4.2 指拨开关S2

DIP开关S2控制对CFW500-SFY2编程模式的访问，可以选择使用哪个安全功能，也可以定义SS1-t的延迟时间。编程过程详见第16页第3.3节“配置安全功能”。

表 2.6: DIP开关S2

配置	描述
	<p>两个DIP开关均设置为“ON”。</p> <p>此配置启动CFW500-SFY2的编程模式，在人机界面上显示警报A0162。要对安全功能模块进行编程，请按照第16页第3.3节“配置安全功能”进行操作。</p>
	<p>一个DIP开关设置为ON，另一个设置为OFF。</p> <p>这是无效的组合，无法完成编程。</p>
	<p>一个DIP开关设置为ON，另一个设置为OFF。</p> <p>这是无效的组合，无法完成编程。</p>
	<p>两个DIP开关均设置为OFF。</p> <p>此配置使CFW500-SFY2的编程模式失效。</p>



注意!

当CFW500-SFY2处于安全状态时，DIP开关S2必须设置在“ON”位置，在人机界面上显示警报A0160。如果有人尝试从安全状态以外的任何状态进入编程状态将导致故障状态，在人机界面上显示故障F0160。

3 调试

3.1 与安全功能模块相关的参数

CFW50X变频器的与安全功能模块直接相关的参数如下所示。

用于描述参数属性的符号：

- ro = 只读参数。
- sy: 仅当安全功能模块处于编程模式时, 该参数才在人机界面上可见。

3.1.1 参数

P0028-安全功能模块

可调节范围:	0 = STO跳线连接器 1 = CFW500-SFY2	出厂设 - 置:
属性:	ro	
通过人机界面访问组:	<input type="text" value="读取"/>	

描述

它根据表3.1 它根据表17, 识别与变频器连接的安全功能模块。

表 3.1: 识别安全功能模块

名称	描述	P0028
STO跳线连接器	无安全功能的变频器。	0
CFW500-SFY2	变频器配备了能够执行STO和SS1-t的安全功能模块。	1



注意!

STO 跳线连接器或 CFW500-SFY2 安全功能模块必须安装在变频器顶部或内部。否则, 变频器接通电源时将显示故障信息“ F0086”。

P0106 - 第3 斜坡时间

可调节范围:	0.1 至 999.0秒	出厂设 5.0 秒 置:
属性:		
通过人机界面访问组:		

描述

它定义了第3 斜坡从零加速到最大速度 (P0134) 的时间或从最大速度 (P0134) 减速到零的时间。



注意!

当请求SS1-t安全功能时, 变频器使用第 3斜坡使电动机减速。因此, 使用SS1-t时, 仅在配置CFW500-SFY2时修改此参数。

P0108 - SS1-t时间

可调节范围: 0 至 999秒

出厂设置: 0 秒

属性: sy

通过人机界面访问组:

描述

它定义了要在安全功能模块中编辑SS1-t安全功能的延迟时间。如果延迟时间值为0秒，则安全功能模块可以编辑STO安全功能。



注意!

P0108仅在人机界面上可见，因此只能在安全功能模块处于编辑模式时才能修改。

P0109 - SS1-t时间确认

可调节范围: 0 至 999秒

出厂设置:

属性: ro、sy

通过人机界面访问组:

描述

在安全功能模块的编辑过程中，它显示在安全模块中编辑的延迟时间的实际值，供用户确认。



注意!

P0109仅在人机界面上可见，因此只有在安全功能模块处于编程模式时才能访问。

3.2 启动

启动顺序：

- 1) 按照CFW50X用户手册和安全手册进行变频器的机电安装。
- 2) 根据安全信号的类型（干接点或OSSD）配置DIP开关S1，将DIP开关S2设置为“OFF”。
- 3) 将安全输入设置为安全状态，即断开触点或在ST01和ST02上施加0 V电压。
- 4) 确保电动机未与机器连接，或者如果已连接，则电动机必须能够沿任何方向旋转都不会造成人身伤害或机器损坏的风险。
- 5) 给变频器通电。
- 6) 通过P0204加载CFW50X出厂默认参数，并核实参数P0028显示为1（CFW500-SFY2）。
- 7) 根据应用要求对变频器进行编程。
- 8) 如果需要SS1-t安全功能，请按照第19页第3.3节的“配置安全功能”中所述的步骤进行操作。
- 9) 将安全输入设置为工作状态，即闭合触点或同时在ST01和ST02上施加+24 V电压。
- 10) 按下人机界面的“ I ”和“ 0 ”键，检查电动机是否在运行和停止。
- 11) 运行电动机并将安全输入设置为安全状态，即断开触点或同时在ST01和ST02上施加0 V电压。
- 12) 激活安全状态后，检查电机是否停止，并在人机界面上显示警报A0160。
- 13) 将安全输入设置为工作状态，即闭合触点或同时在ST01和ST02上施加+24 V电压。
- 14) 再次使用“ I ”和“ 0 ”键检查电动机是否运行。
- 15) 检查所有其他应用程序功能，确保安装CFW50X的系统的正确操作和整体安全。



注意！

以上步骤是验证变频器安全功能完整性的最低要求。为了验证机器或系统的整体运行和安全性，可能需要其他步骤。机器制造商负责对使用变频器的机器或系统的安全性进行最终验证。



注意！

无论何时重新配置安全功能，都必须进行操作验证测试。

**注意!**

同时激活安全输入意味着启用或停用输入之间的时间必须小于1 秒。此时间也叫差异时间。如果差异时间超过1 秒，则人机界面上将显示故障F0160。要复位该故障，需要将两个安全输入（STO1和STO2）都设置为相同的逻辑状态，然后使变频器断电并重新通电。

**注意!**

可以允许OSSD输出中的测试脉冲，其不会激活安全功能，前提是它们符合以下规范：

- 脉冲持续时间: <1毫秒。
- 同一通道上的脉冲间隔: > 8毫秒。
- 不同通道上的脉冲间隔: > 4毫秒。

3.3 配置安全功能

SS1-t安全功能的受控延迟时间可用来选择CFW500-SFY2中配置的安全功能。如果将延迟时间编辑为0秒，则选择的是STO；而从1秒到999 秒的值配置的是SS1-t安全功能。

**注意!**

受控延迟时间的出厂默认值为0 秒，也就是说，CFW500-SFY2已预先配置了STO安全功能。

通过设置CFW500-SFY2的DIP开关S2并通过人机界面定义参数P0106、P0108和P0109来编辑延迟时间，步骤如下。

- 1) 执行第20页3.2节“启动”中所述的启动顺序。
- 2) 确保变频器处于安全状态，即安全输入已禁用，并且人机界面显示警报A0160。

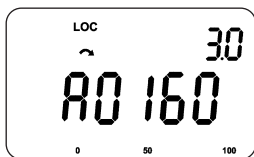

- 3) 将两个DIP开关S2都置于“ON”位置。人机界面必须显示警报A0162，这意味着安全功能模块已进入编程模式。

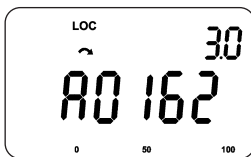
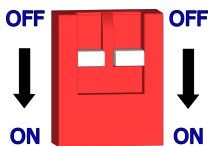

- 4) 将参数P0108设置为所需的延迟时间值（例如15秒），如下所示。然后，按“ENTER”键。此时，显示屏背光开始闪烁，用户必须通过参数P0109确认编程值。

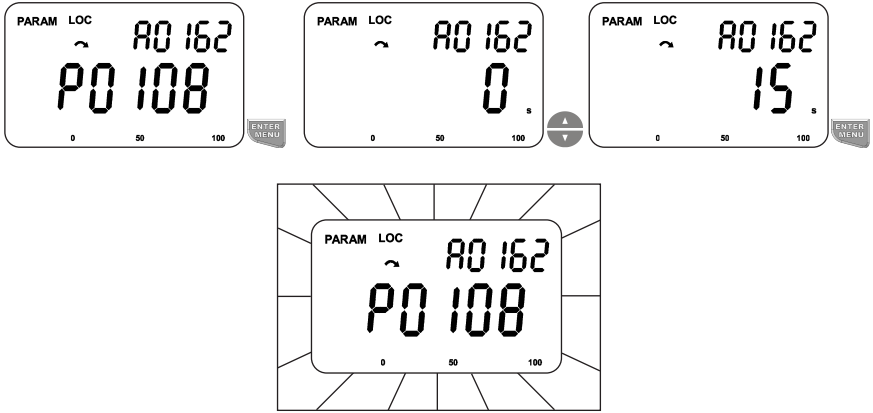

- 5) 要确认编程值，访问参数P0109，然后检查P0109中显示的值是否与P0108中编程的值相同。如果值相同，按“ENTER”键确认。此时，显示屏背光应停止闪烁。如果P0108和P0109的值不同，则用户必须按“ESC”键，中止编程过程然后跳到故障F0160。

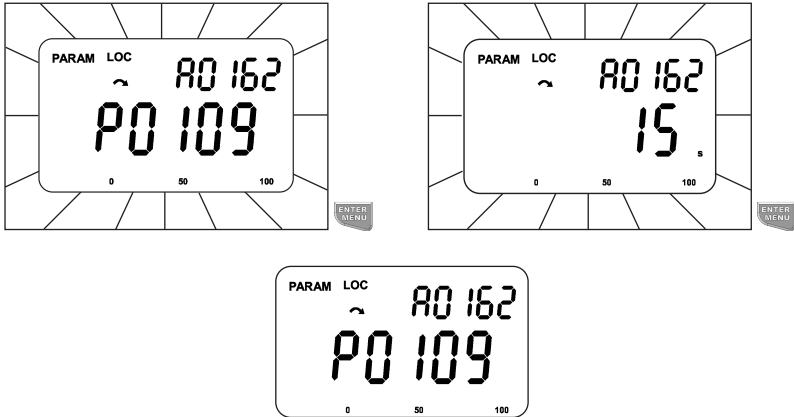
注意!

如果延迟时间编程失败或中止，则保留最后的编程值。



注意!

如果编程过程闲置超过2分钟，则变频器将跳至故障F0160。要复位该故障，要将变频器断电并重新通电。

**注意!**

如果用户确认P0109中的值与P0108中刚刚编程的值不同，则变频器将跳至故障F0160。要复位该故障，要将变频器断电并重新通电。

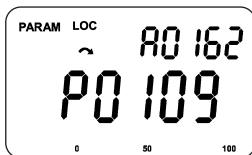
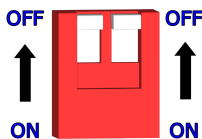
- 6) 在编辑并确认了延迟时间值之后，用户必须将DIP开关S2返回到“OFF”位置。此时，变频器退出编程模式（A0162），并返回到安全状态（A0160）。



- 7) 在参数P0106上为变频器在SS1-t安全功能要求期间执行的减速斜坡设置减速时间。

**注意!**

对于STO安全功能，参数P0106与安全功能的性能无关，所以可以跳过该步骤。

- 8) 将安全输入设置为操作状态。变频器应可以清除显示屏上的警报A160。

- 9) 按人机界面上的“ I ”键运行电动机。

- 10) 电动机运行时，将安全输入恢复到安全状态，检查变频器（P0106）施加的SS1-t延迟时间（P0108）和减速斜坡（P0106）是否适用于应用。如果不是，则使用适当的时间值重复此编程过程。

**注意!**

在SS1-t安全功能计时（延迟时间）期间，人机界面上会显示警报A0161。在此延迟时间之后，人机界面将显示警报A0160。

**注意!**

通过参数P0204将变频器设置为出厂默认参数设置不会影响CFW500-SFY2安全功能模块中已编辑的延迟时间。

**注意!**

通过CFW500-MMF（闪存模块）复制参数不会影响CFW500-SFY2安全功能模块中的编程延迟时间。

4 保养与故障排除

4.1 保养

CFW500变频器配备了多种自诊断功能和人机界面显示的信息，可帮助用户识别变频器或其安装中的问题。

特别是CFW500-SFY2安全功能模块配备了非常精确的自诊断电路，即使在故障条件下，也可以确保很高的安全性。与安全相关的故障报告为“F0160”，故障包括安全信号连接错误、安全功能模块配置错误以及内部电路损坏。有关故障F0160的最常见原因，请参见第23页第4.2节“与安全功能模块有关的警报和故障”。

如果变频器显示屏上显示故障F0160，并且识别不出外部问题，则安全功能模块中可能存在内部问题。在这种情况下，必须使变频器停止运行，然后将其提交给授权的服务中心。请与您当地的WEG供应商联系，咨询如何进行。

**注意！**

切勿自己尝试修复或允许未经授权的人员修复任何WEG产品。如有违反本产品规定，本变频器的安全保证将自动失效。

**注意！**

CFW500-SFY2安全功能模块没有备件。万一损坏，则必须更换新的。

**注意！**

变频器的功能安全电路设计无需维护或定期测试。电路定期自检，如发现任何问题，会通知用户。

**注意！**

当CFW500-SFY2安全功能模块检测到故障情况，且使用的是SS1-t安全功能时，变频器尝试在启动故障F0160之前执行电机减速（A0161），就像平常SS1-t安全功能由安全输入启动时一样。

**注意！**

故障F0160也代表安全转矩关闭状态。

**注意！**

在对机器或系统进行维修后，必须重新检查总体安全性，以验证机器或系统的安全完整性。此外，如有任何修改，必须重复验证安全功能并形成记录文件。

**注意！**

如果在安全功能启动期间变频器的两个或多个绝缘栅双极晶体管（IGBT）上同时发生故障，则变频器可能会提供足够的能量以进行转子与电动机内部磁极之间的磁校准。该移动范围取决于电动机的磁极数，并且最大只可移动180°。尽管这种情况不太可能发生，但是请确保如果发生这种情况不会对人员造成伤害或对机器造成损坏。

4.2 与安全功能模块有关的警报和故障

A0160 - 安全状态启用

描述

它告诉用户安全状态处于启用状态。

可能的原因/纠正：

- 安全输入 (ST01和ST02) 的致动。
- 未安装安全输入电路。
- 安全输入电路断开。

A0161 - SS1-t计时启用

描述

告诉用户安全功能模块正在执行SS1-t安全功能的计时，变频器使电动机减速。

可能的原因/纠正：

- 配置了SS1-t安全功能的安全输入 (ST01和ST02) 的致动。
- 配置的SS1-t安全功能检测到故障。

A0162 - 编程模式下的安全功能模块

描述

告诉用户安全功能模块处于安全功能的编程模式。

可能的原因/纠正：

- 在安全状态下启动了安全功能模块的DIP开关 (S2) 的编程模式。

F0160 - 安全功能模块处于故障状态

描述

向用户指示安全功能模块处于故障状态。

可能的原因/纠正：

- 安全输入电路安装不正确。
- 安全输入 (ST01和ST02) 之间的差异大于1秒。
- DIP开关S1上安全输入类型 (干接点或OSSD) 的配置不正确。
- 在运行状态下启动了安全功能模块的DIP开关 (S2) 的编程模式。
- 安全功能的编程不正确或编程超时 (2分钟)。
- 安全功能模块的电子电路损坏。

F0161 – 安全功能模块通讯故障**描述**

告诉用户变频器已与安全功能模块失去通信。

可能的原因/纠正:

- 安全功能模块和变频器之间的接触不良。
- 变频器控制或安全功能模块的电子电路损坏。

5 停止运行

如需停止运行，最好将机器或系统断开所有电源。如果无法断开所有电源，则必须先关闭变频器的所有电气连接（即电源连接和控制连接），然后再进行任何停机操作。

**危险！**

在停止运行之前，有必要对机器或系统的安全性进行分析。悬挂负载、制动器或旋转部件可能需要电才能保持安全状态，断电可能导致不安全状况。确保以安全的方式断电。

**危险！**

即使在关闭或断开电源之后，变频器仍可能保持高电压和/或有转动的部件（风扇）。至少等待 10 分钟，保证内部部件完全放电。

APPENDIX A – FIGURES ANEXO A – FIGURAS

附录A – 图

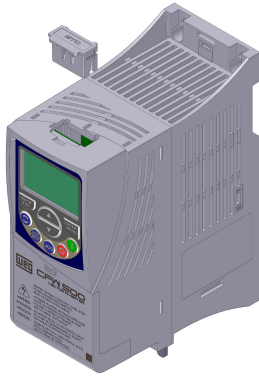

- a) Removal of the STO jumper connector
(Frame sizes A to E)
- a) Remoción del conector jumper STO
(Tamaños A a E)
- a) Remoção do conector jumper STO
(Mecânicas A a E)
- a) 拆除STO跳线连接器 (帧尺寸A至E)

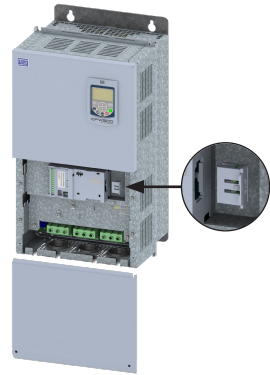

- (b) Removal of the STO jumper connector
(Frame sizes F and G)
- (b) Remoción del conector jumper STO
(Tamaños F y G)
- (b) Remoção do conector jumper STO
(Mecânicas F e G)
- (b) 拆除STO跳线连接器 (帧尺寸F和G)



- c) Connection of the CFW500-SFY2
(Frame sizes A to E)
- c) Conexión del accesorio CFW500-SFY2
(Tamaños A a E)
- c) Conexão do acessório CFW500-SFY2
(Mecânicas A a E)
- c) 连接CFW500-SFY2 (帧尺寸A至E)

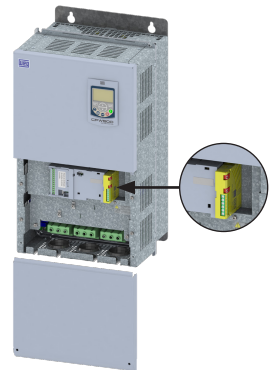

- d) Connection of the CFW500-SFY2
(Frame sizes F and G)
- d) Conexión del accesorio CFW500-SFY2
(Tamaños F y G)
- d) Conexão do acessório CFW500-SFY2
(Mecânicas F e G)
- d) 连接CFW500-SFY2 (帧尺寸F和G)

Figure A.1: (a) to (d) Installation of the CFW500-SFY2 safety functions module

Figura A.1: (a) a (d) Instalación del módulo de funciones de seguridad CFW500-SFY2

Figura A.1: (a) a (d) Instalação do módulo de funções de segurança CFW500-SFY2

图A.1: (a) 至 (d) CFW500-SFY2安全功能模块的安装

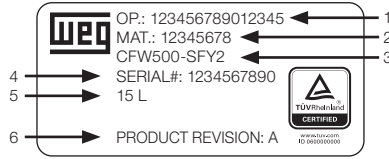

- | | | | |
|--------------------------|-----------------------------|---------------------------|------------|
| 1 - WEG production order | 1 - Orden de producción WEG | 1 - Ordem de produção WEG | 1-WEG生产单 |
| 2 - WEG stock item | 2 - Ítem de stock WEG | 2 - Material WEG | 2-WEG 常备商品 |
| 3 - Accessory model | 3 - Modelo de lo accesorio | 3 - Modelo do acessório | 3-配件型号 |
| 4 - Serial number | 4 - Número de serie | 4 - Número de série | 4-序列号 |
| 5 - Manufacturing date | 5 - Fecha de fabricación | 5 - Data de fabricação | 5-制造日期 |
| 6 - Product revision | 6 - Revisión del producto | 6 - Revisão do produto | 6-产品版本 |

Figure A.2: CFW500-SFY2 identification label

Figura A.2: Etiqueta de identificación del CFW500-SFY2

Figura A.2: Etiqueta de identificação do CFW500-SFY2

图A.2: CFW500-SFY2识别标签

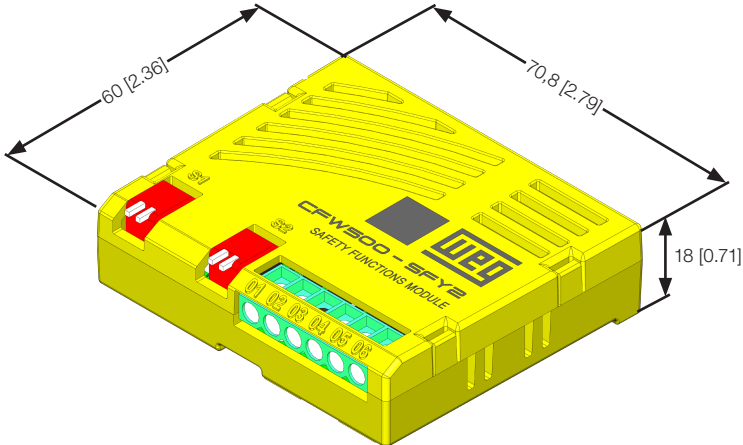

Figure A.3: CFW500-SFY2 dimensions in mm [in]

Figura A.3: Dimensiones del CFW500-SFY2 en mm [in]

Figura A.3: Dimensões do CFW500-SFY2 em mm [in]

图A.3: CFW500-SFY2尺寸（单位为毫米[英寸]）