

Non-reversing motor starter Size 3 1/2 Three phase full voltage  
 Solid-state overload relay OLRelay amp range 50-200A 220-  
 240/440-480VAC 60HZ coil Combination type No enclosure



Figure similar

product brand name	Class 14
design of the product	Full-voltage non-reversing motor starter
special product feature	ESP200 overload relay; Half-size starter; Dual voltage coil

General technical data	
weight [lb]	8 lb
Height x Width x Depth [in]	9.78 × 6.75 × 5.19 in
touch protection against electrical shock	Not finger-safe
installation altitude [ft] at height above sea level maximum	6560 ft
ambient temperature [°F]	
• during storage	-22 ... +149 °F
• during operation	-4 ... +104 °F
ambient temperature	
• during storage	-30 ... +65 °C
• during operation	-20 ... +40 °C
country of origin	Mexico

### Horsepower ratings

yielded mechanical performance [hp] for 3-phase AC motor	
<ul style="list-style-type: none"> <li>• at 200/208 V rated value</li> </ul>	30 hp
<ul style="list-style-type: none"> <li>• at 220/230 V rated value</li> </ul>	40 hp
<ul style="list-style-type: none"> <li>• at 460/480 V rated value</li> </ul>	75 hp
<ul style="list-style-type: none"> <li>• at 575/600 V rated value</li> </ul>	75 hp

### Contactors

size of contactor	Controller half size 3 1/2
number of NO contacts for main contacts	3
operating voltage for main current circuit at AC at 60 Hz maximum	600 V
operational current at AC at 600 V rated value	115 A
mechanical service life (switching cycles) of the main contacts typical	5000000

### Auxiliary contact

number of NC contacts at contactor for auxiliary contacts	0
number of NO contacts at contactor for auxiliary contacts	1
number of total auxiliary contacts maximum	7
contact rating of auxiliary contacts of contactor according to UL	10A@600VAC (A600), 5A@600VDC (P600)

### Coil

type of voltage of the control supply voltage	AC
control supply voltage	
<ul style="list-style-type: none"> <li>• at AC at 60 Hz rated value</li> </ul>	220 ... 480 V
holding power at AC minimum	14 W
apparent pick-up power of magnet coil at AC	310 V·A
apparent holding power of magnet coil at AC	26 V·A
operating range factor control supply voltage rated value of magnet coil	0.85 ... 1.1
percental drop-out voltage of magnet coil related to the input voltage	50 %
switch ON delay time	26 ... 41 ms
OFF delay time	14 ... 19 ms

### Overload relay

product function	
<ul style="list-style-type: none"> <li>• overload protection</li> </ul>	Yes
<ul style="list-style-type: none"> <li>• phase failure detection</li> </ul>	Yes
<ul style="list-style-type: none"> <li>• asymmetry detection</li> </ul>	Yes
<ul style="list-style-type: none"> <li>• ground fault detection</li> </ul>	Yes
<ul style="list-style-type: none"> <li>• test function</li> </ul>	Yes

• external reset	No
reset function	Manual, automatic and remote
trip class	Class 5 / 10 / 20 (factory set) / 30
adjustable current response value current of the current-dependent overload release	50 ... 200 A
tripping time at phase-loss maximum	3 s
relative repeat accuracy	1 %
product feature protective coating on printed-circuit board	Yes
number of NC contacts of auxiliary contacts of overload relay	1
number of NO contacts of auxiliary contacts of overload relay	1
operational current of auxiliary contacts of overload relay	5 A 1 A
• at AC at 600 V	5 A
• at DC at 250 V	1 A
contact rating of auxiliary contacts of overload relay according to UL	5A@600VAC (B600), 1A@250VDC (R300)
insulation voltage	600 V 300 V
• with single-phase operation at AC rated value	600 V
• with multi-phase operation at AC rated value	300 V

#### Enclosure

degree of protection NEMA rating	Open device (no enclosure)
design of the housing	NA

#### Mounting/wiring

mounting position	Vertical
fastening method	Surface mounting and installation
type of electrical connection for supply voltage line-side	Box lug
tightening torque [lbf-in] for supply	120 ... 120 lbf-in
type of connectable conductor cross-sections at line-side at AWG cables single or multi-stranded	1x(14 - 2/0 AWG)
temperature of the conductor for supply maximum permissible	75 °C
material of the conductor for supply	AL or CU
type of electrical connection for load-side outgoing feeder	Box lug
tightening torque [lbf-in] for load-side outgoing feeder	120 ... 120 lbf-in
type of connectable conductor cross-sections at AWG cables for load-side outgoing feeder single or multi-stranded	1x(14 - 2/0 AWG)
temperature of the conductor for load-side outgoing feeder maximum permissible	75 °C

material of the conductor for load-side outgoing feeder	AL or CU
type of electrical connection of magnet coil	screw-type terminals
tightening torque [lbf-in] at magnet coil	5 ... 12 lbf-in
type of connectable conductor cross-sections of magnet coil at AWG cables single or multi-stranded	2 x (16 - 12 AWG)
temperature of the conductor at magnet coil maximum permissible	75 °C
material of the conductor at magnet coil	CU
type of electrical connection for auxiliary contacts	screw-type terminals
tightening torque [lbf-in] at contactor for auxiliary contacts	10 ... 15 lbf-in
type of connectable conductor cross-sections at contactor at AWG cables for auxiliary contacts single or multi-stranded	1 x (12 AWG), 2 x (16 - 14 AWG), 2 x (18 - 16 AWG)
temperature of the conductor at contactor for auxiliary contacts maximum permissible	75 °C
material of the conductor at contactor for auxiliary contacts	CU
type of electrical connection at overload relay for auxiliary contacts	screw-type terminals
tightening torque [lbf-in] at overload relay for auxiliary contacts	7 ... 10 lbf-in
type of connectable conductor cross-sections at overload relay at AWG cables for auxiliary contacts single or multi-stranded	2 x (20 - 14 AWG)
temperature of the conductor at overload relay for auxiliary contacts maximum permissible	75 °C
material of the conductor at overload relay for auxiliary contacts	CU

#### Short-circuit current rating

design of the fuse link for short-circuit protection of the main circuit required	10kA@600V (Class H or K); 100kA@600V (Class R or J)
design of the short-circuit trip	Thermal magnetic circuit breaker
breaking capacity maximum short-circuit current (Icu) <ul style="list-style-type: none"> <li>• at 240 V</li> <li>• at 480 V</li> <li>• at 600 V</li> </ul>	14 kA 10 kA 10 kA
certificate of suitability	NEMA ICS 2; UL 508; CSA 22.2, No.14

#### Further information

**Industrial Controls - Product Overview (Catalogs, Brochures,...)**

[www.usa.siemens.com/iccatalog](http://www.usa.siemens.com/iccatalog)

**Industry Mall (Online ordering system)**

<https://mall.industry.siemens.com/mall/en/us/Catalog/product?mlfb=US2:14IUH32AC>

**Service&Support (Manuals, Certificates, Characteristics, FAQs,...)**

<https://support.industry.siemens.com/cs/US/en/ps/US2:14IUH32AC>

Certificates/approvals

<https://support.industry.siemens.com/cs/US/en/ps/US2:14IUH32AC/certificate>

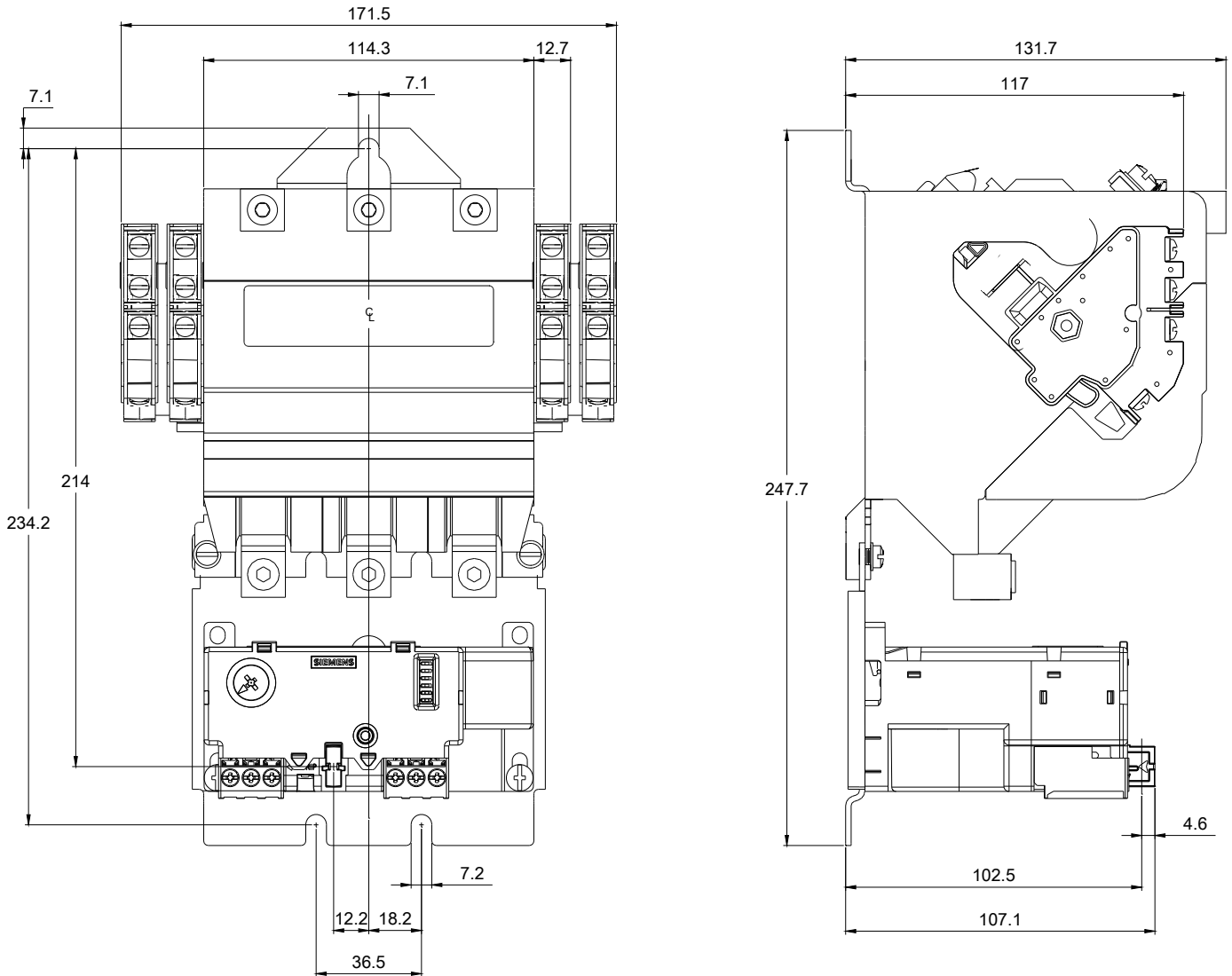

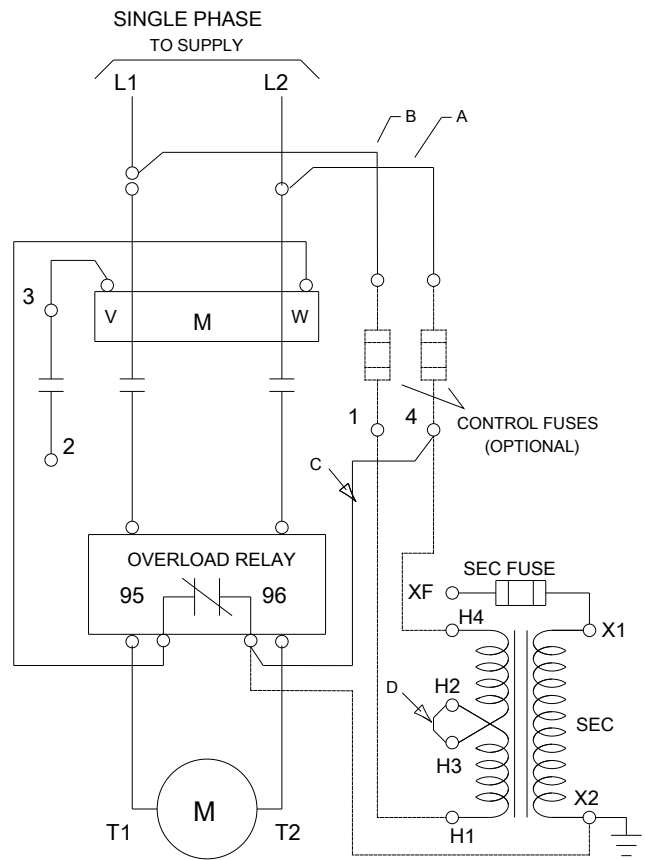
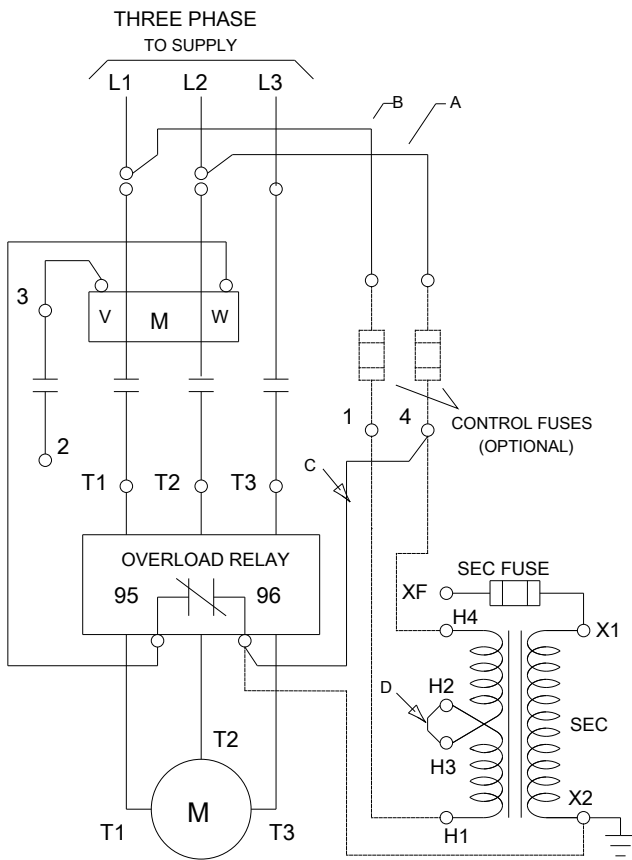

D46590001

last modified:

10/29/2020