

8

7

6

5

4

3

2

1

D

D

C

C

B

B

A

A

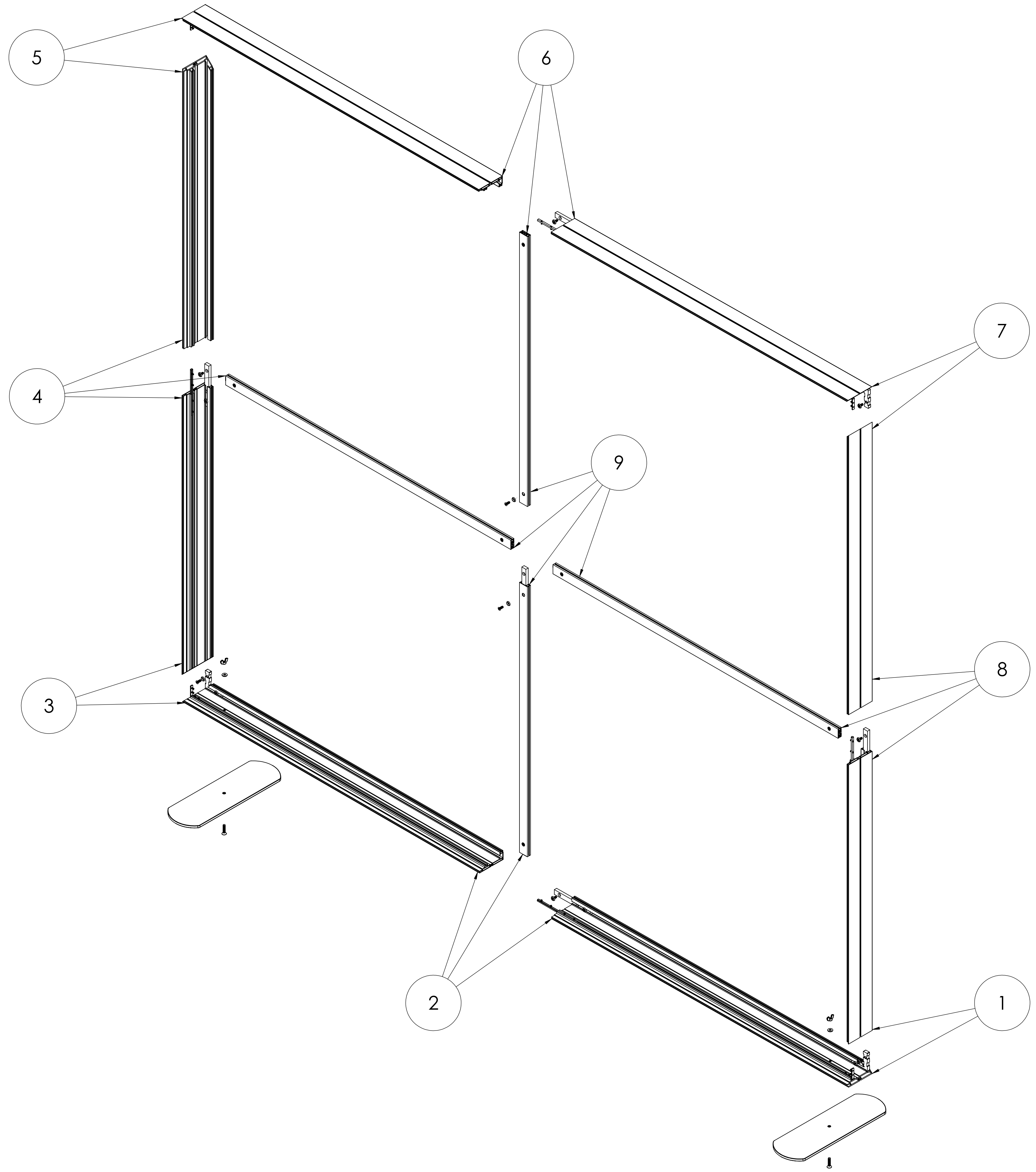

NOTES: UNLESS OTHERWISE SPECIFIED

1. ASSEMBLY TIME: 1 HOUR WITH 2 PERSONS.

2. FEET MAY VARY.



8

7

6

5

4

3

2

1

8

7

6

5

4

3

2

1

D

D

DETAIL B
SCALE 3 : 4

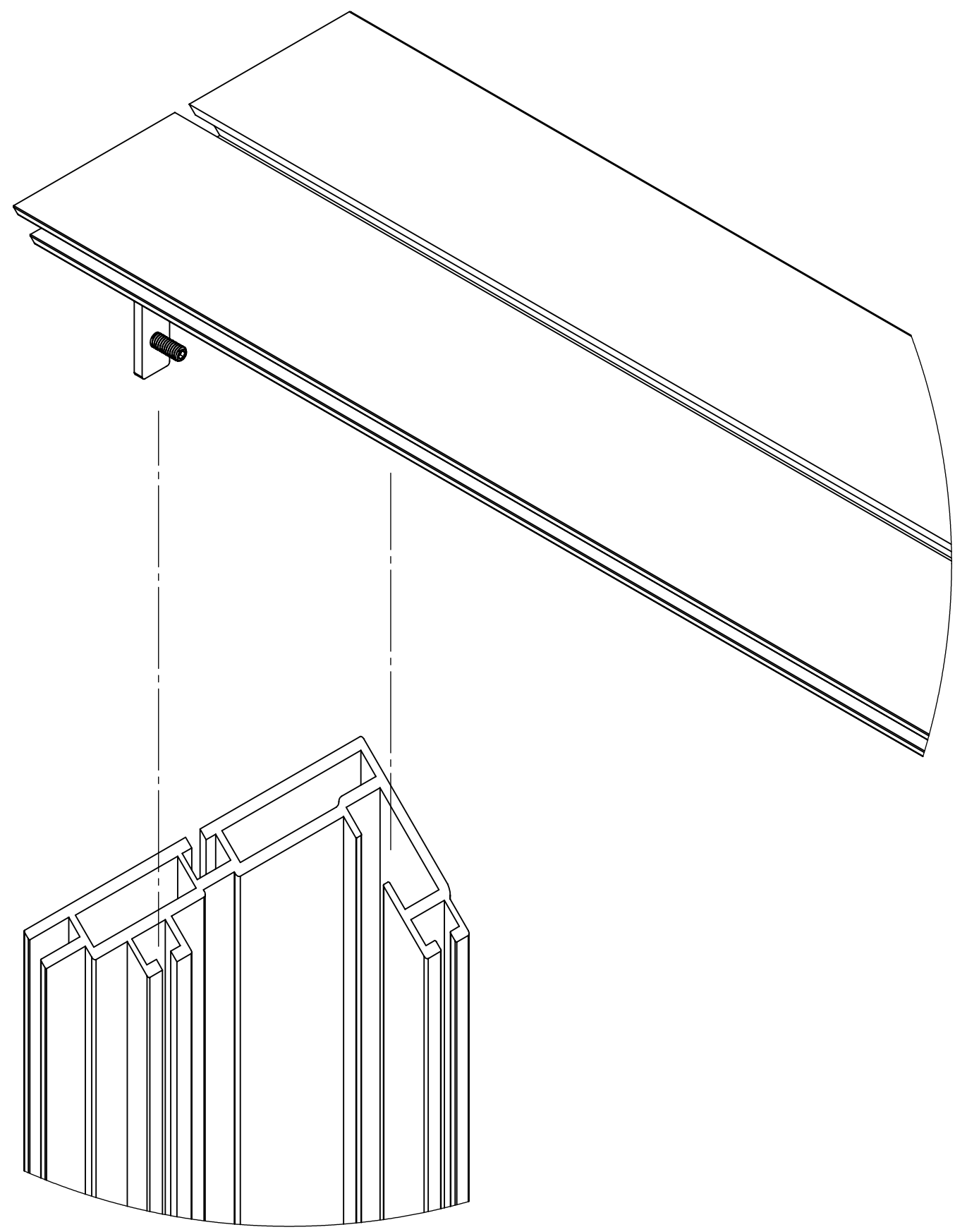

DETAIL C
SCALE 3 : 4

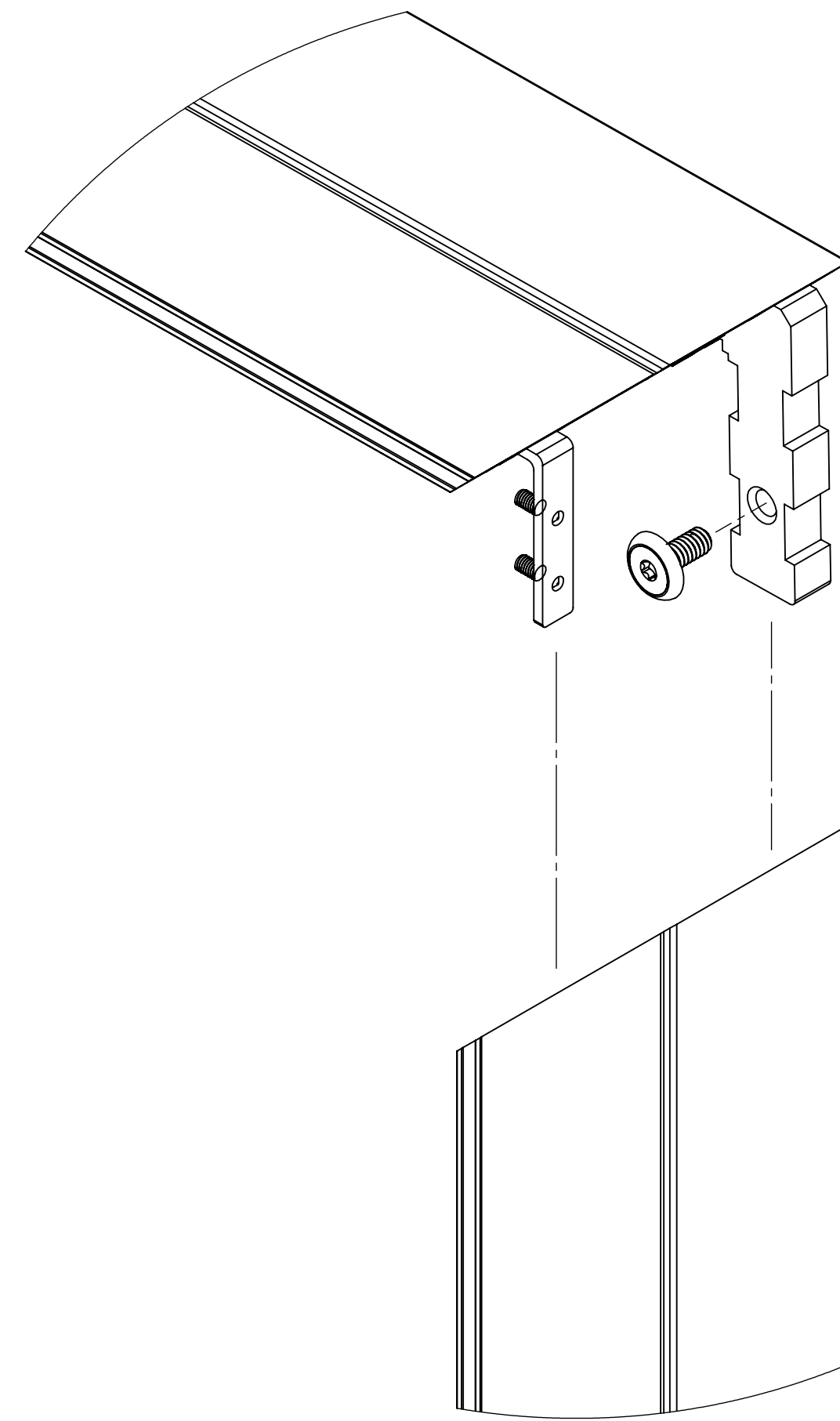

C

C

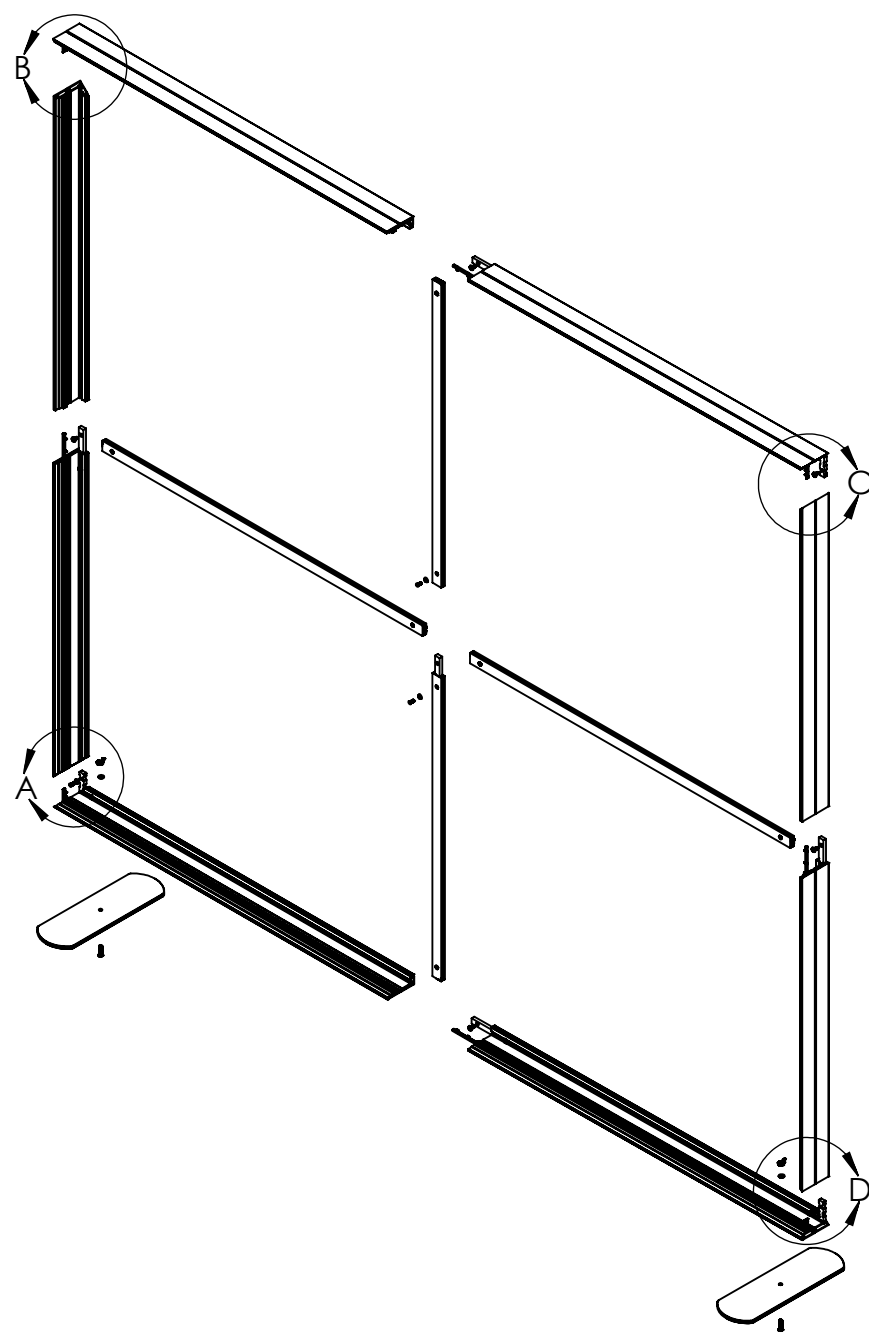

B

B

DETAIL A
SCALE 3 : 4

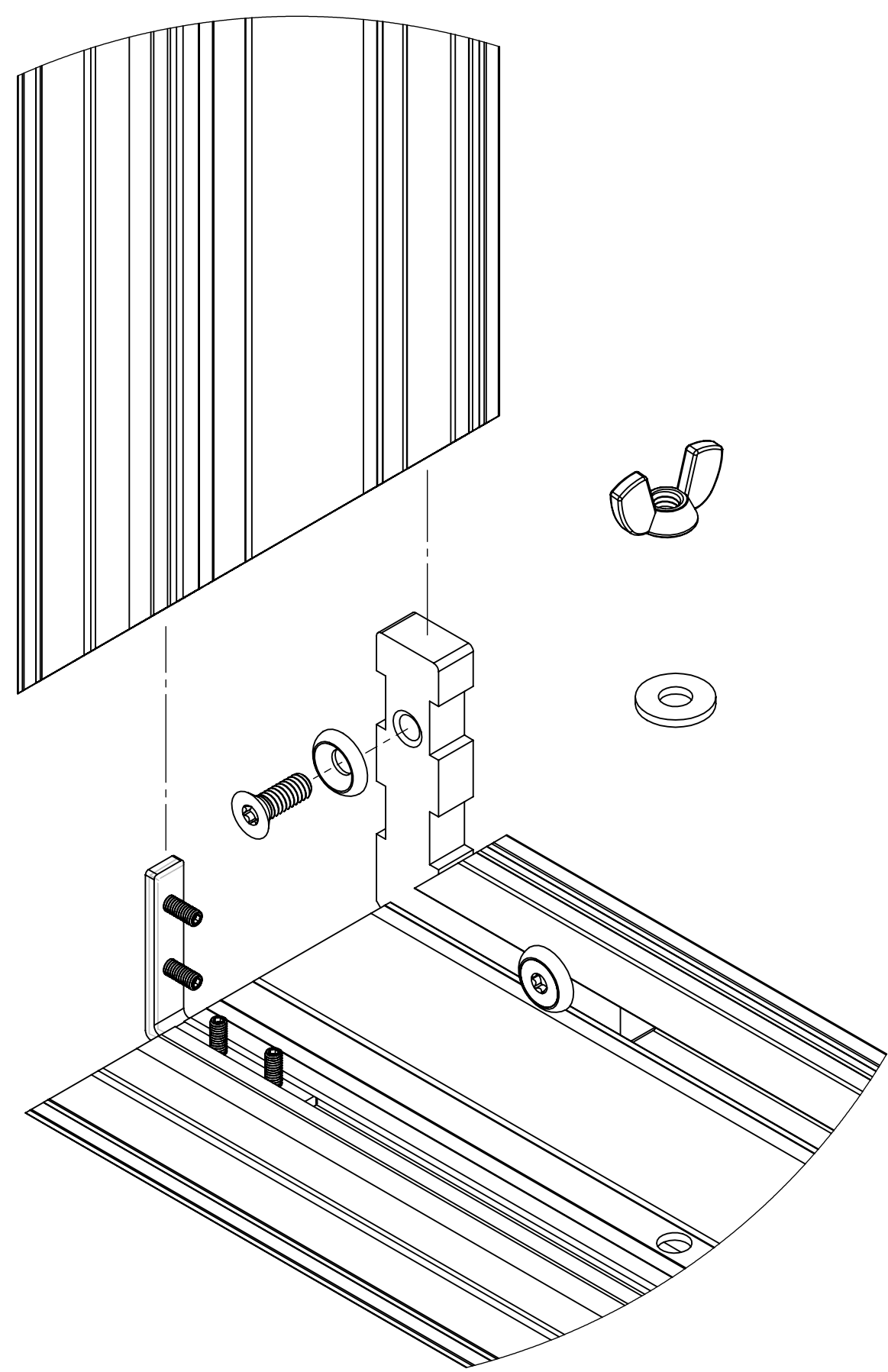

DETAIL D
SCALE 3 : 4

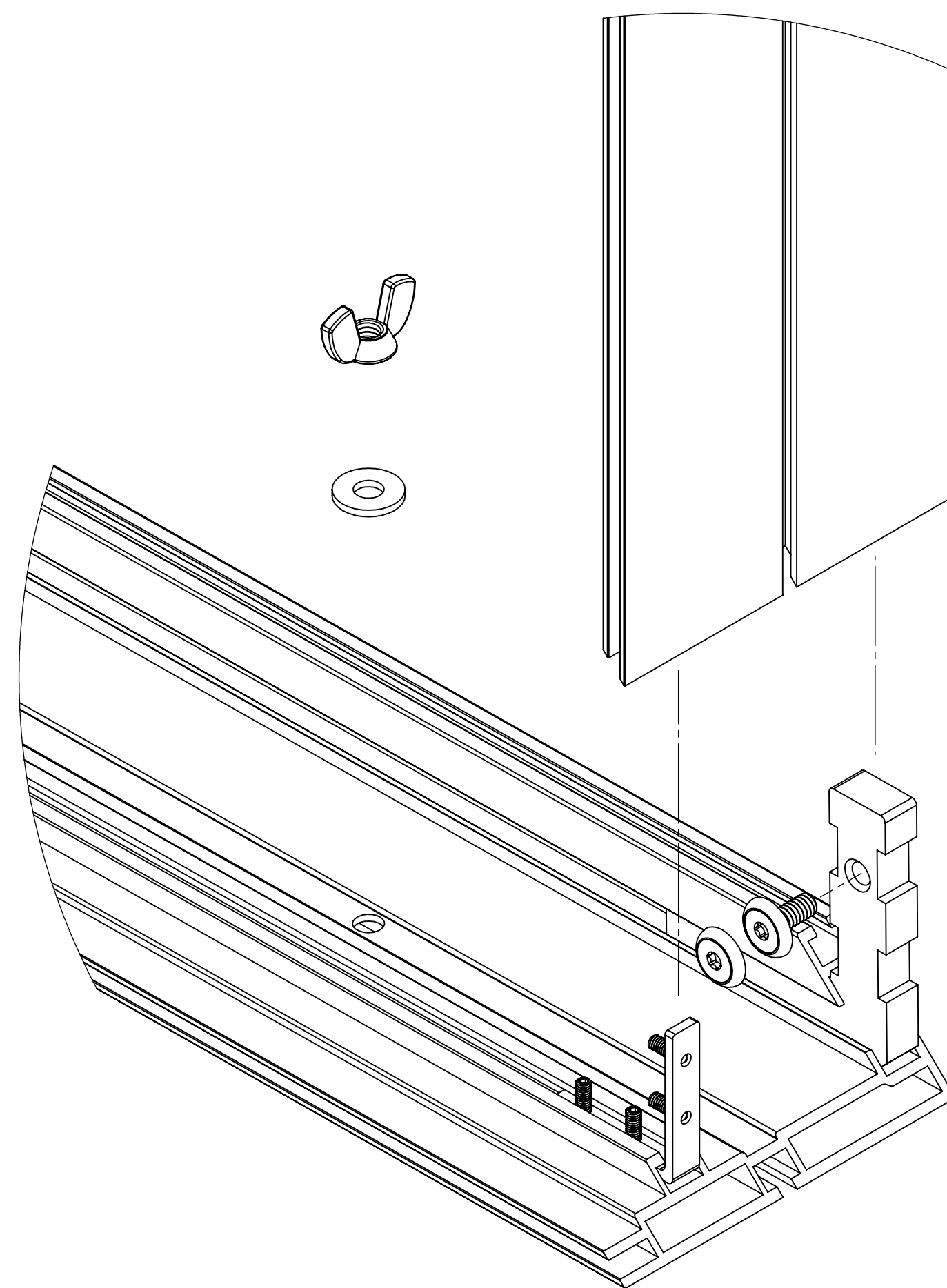

A

A

8

7

6

5

4

3

2

1



8

7

6

5

4

3

2

1

D

D

C

C

B

B

A

A

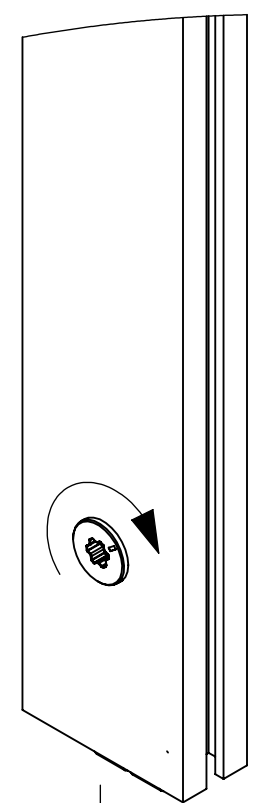
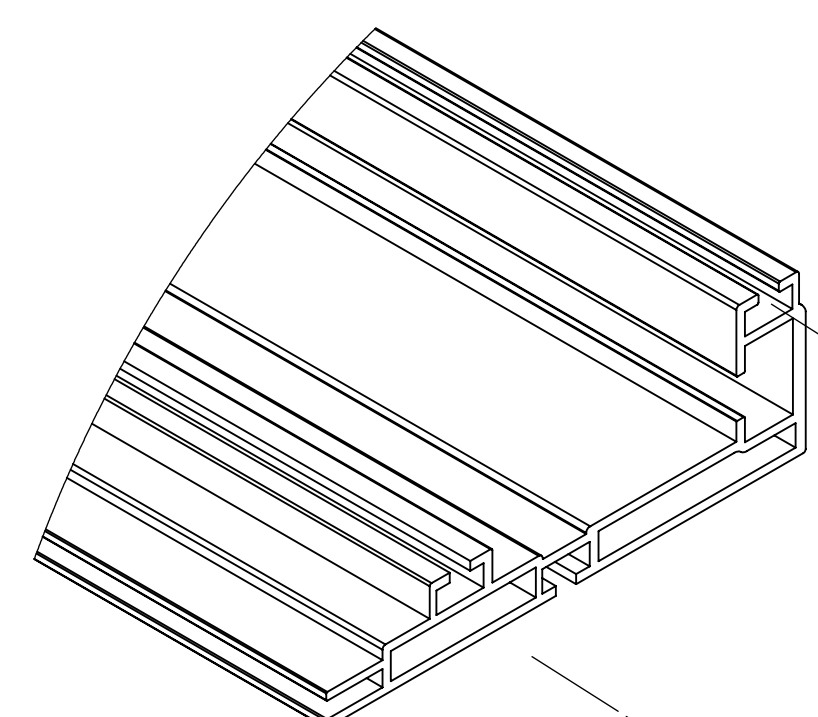

**TURN TO LOCK
AND
REVERSE TO UNLOCK**

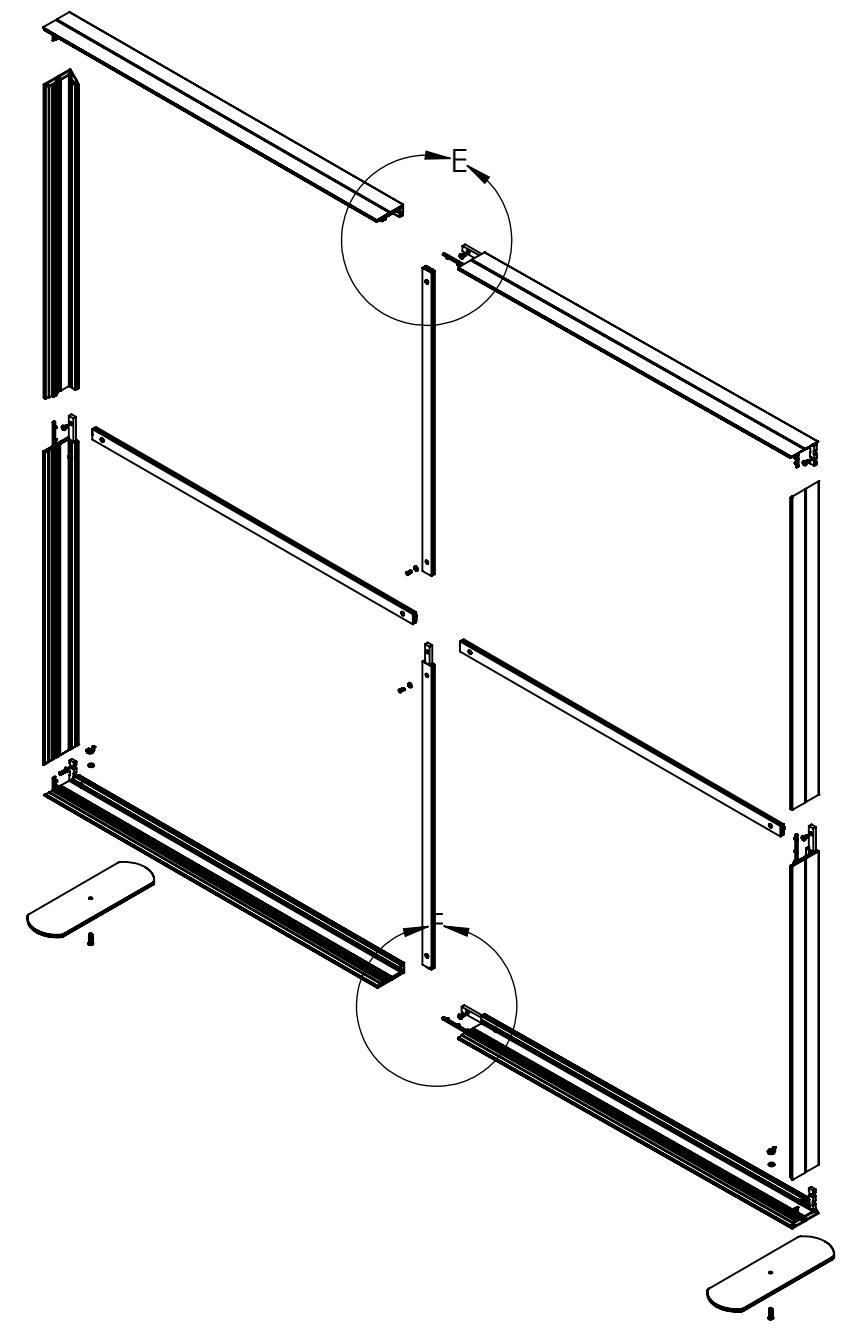

**TURN TO LOCK
AND
REVERSE TO UNLOCK**

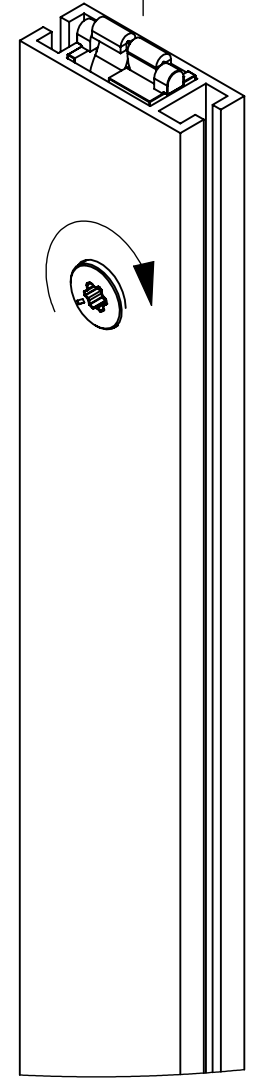

**DETAIL E
SCALE 3 : 4**

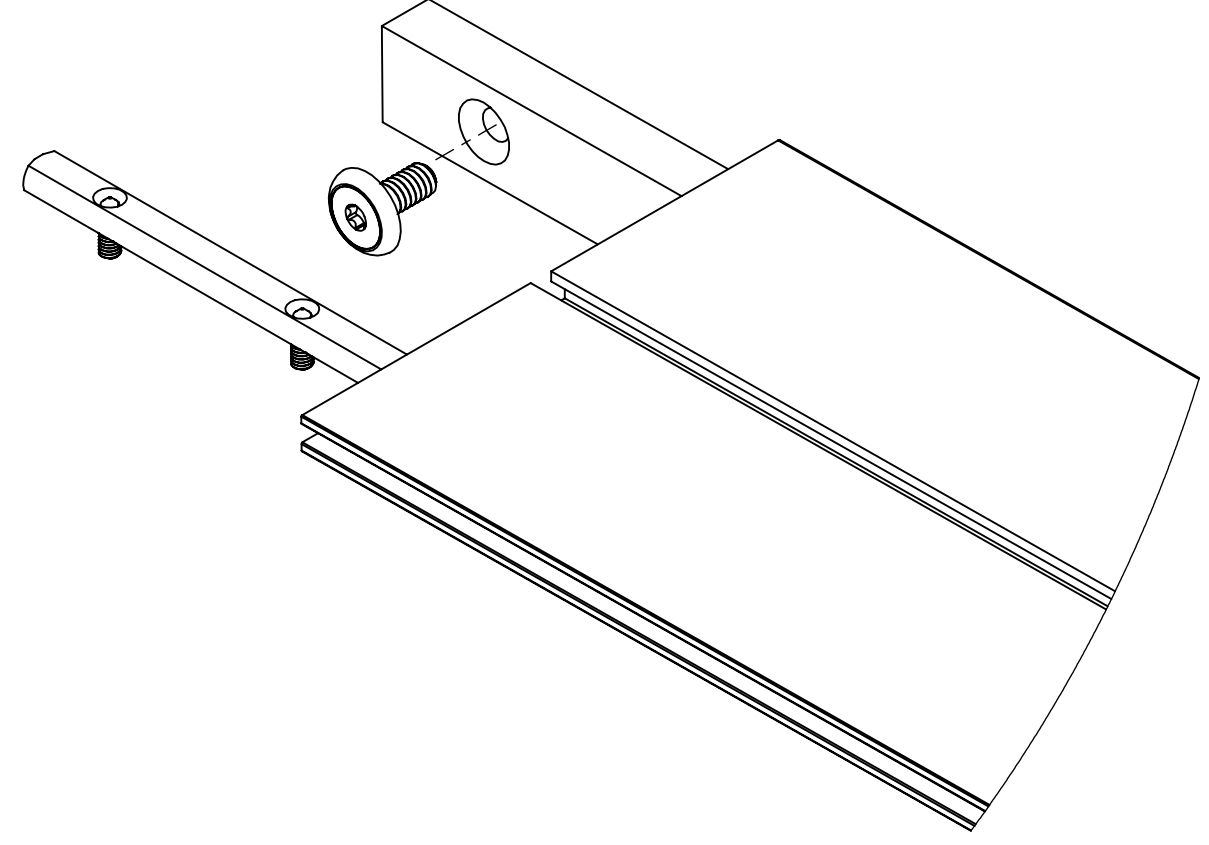

**DETAIL F
SCALE 3 : 4**

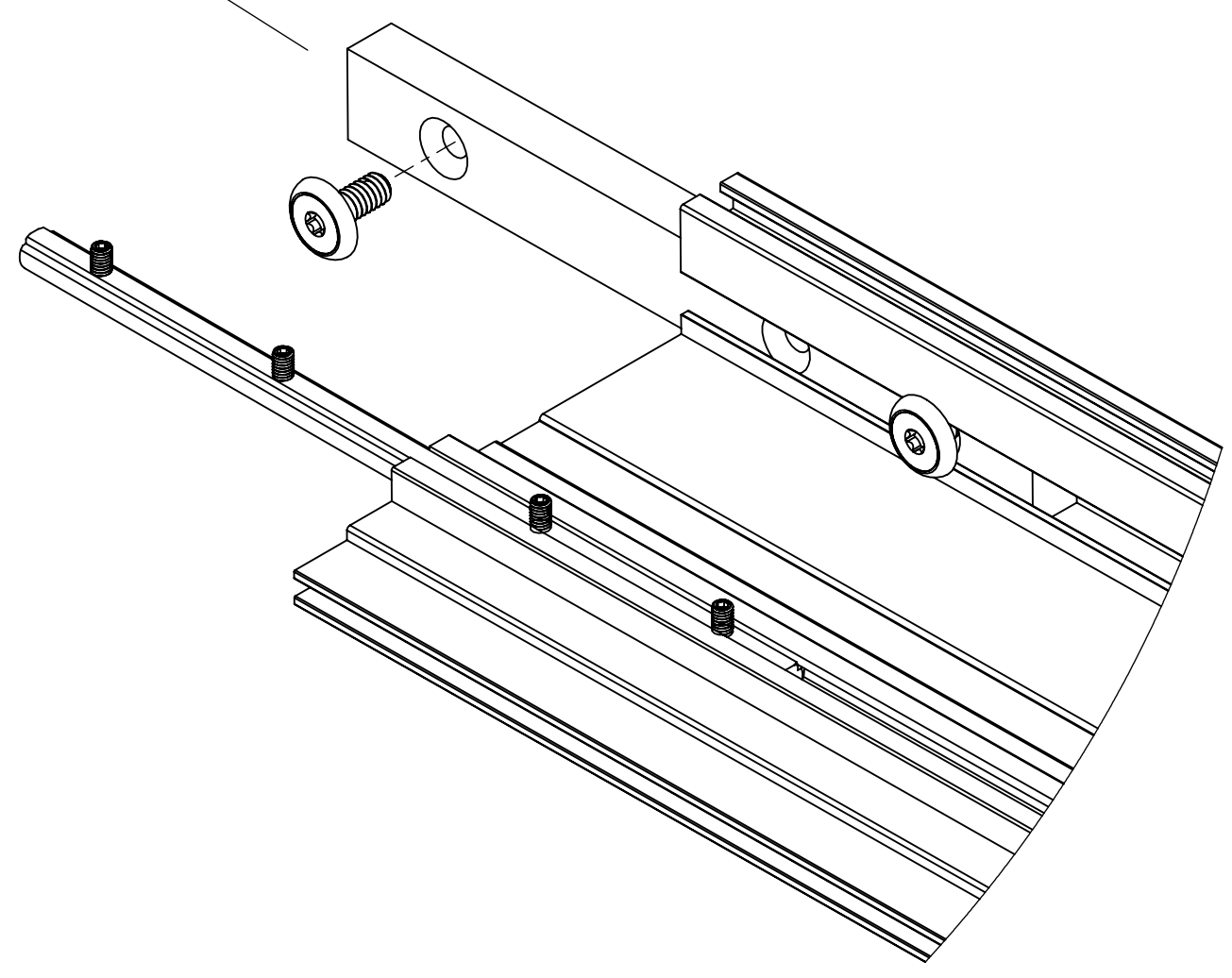

8

7

6

5

4

3

2



8

7

6

5

4

3

2

1

D

D

C

C

B

B

A

A

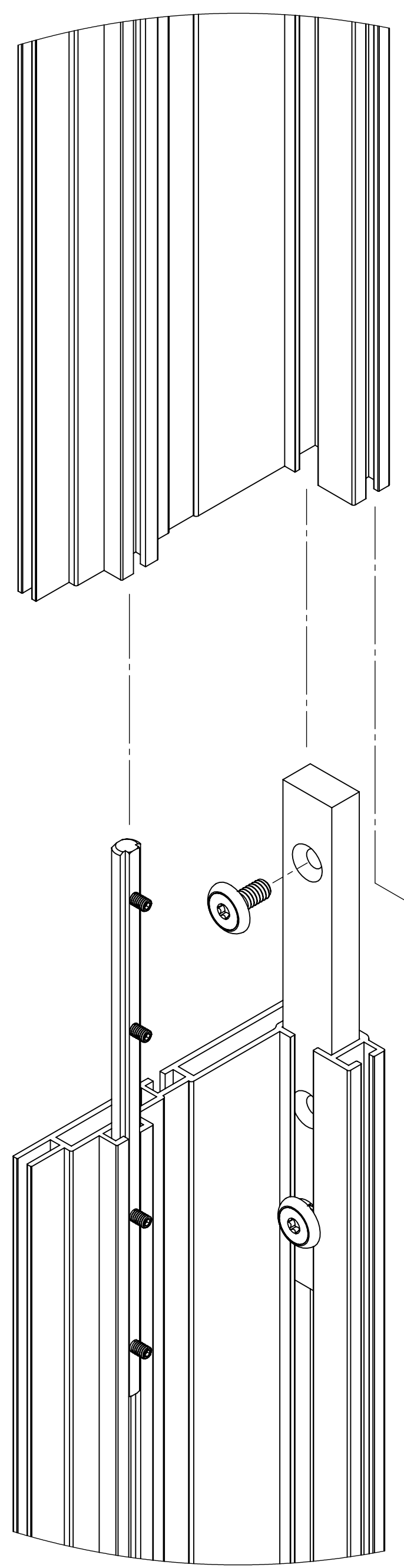

DETAIL G
SCALE 3 : 4

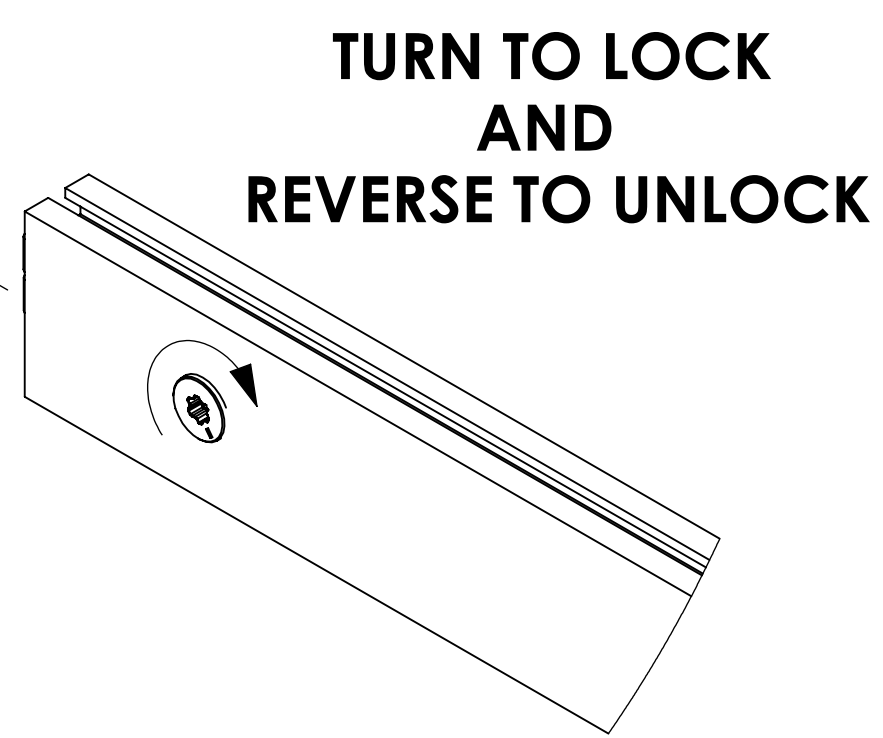

**TURN TO LOCK
AND
REVERSE TO UNLOCK**

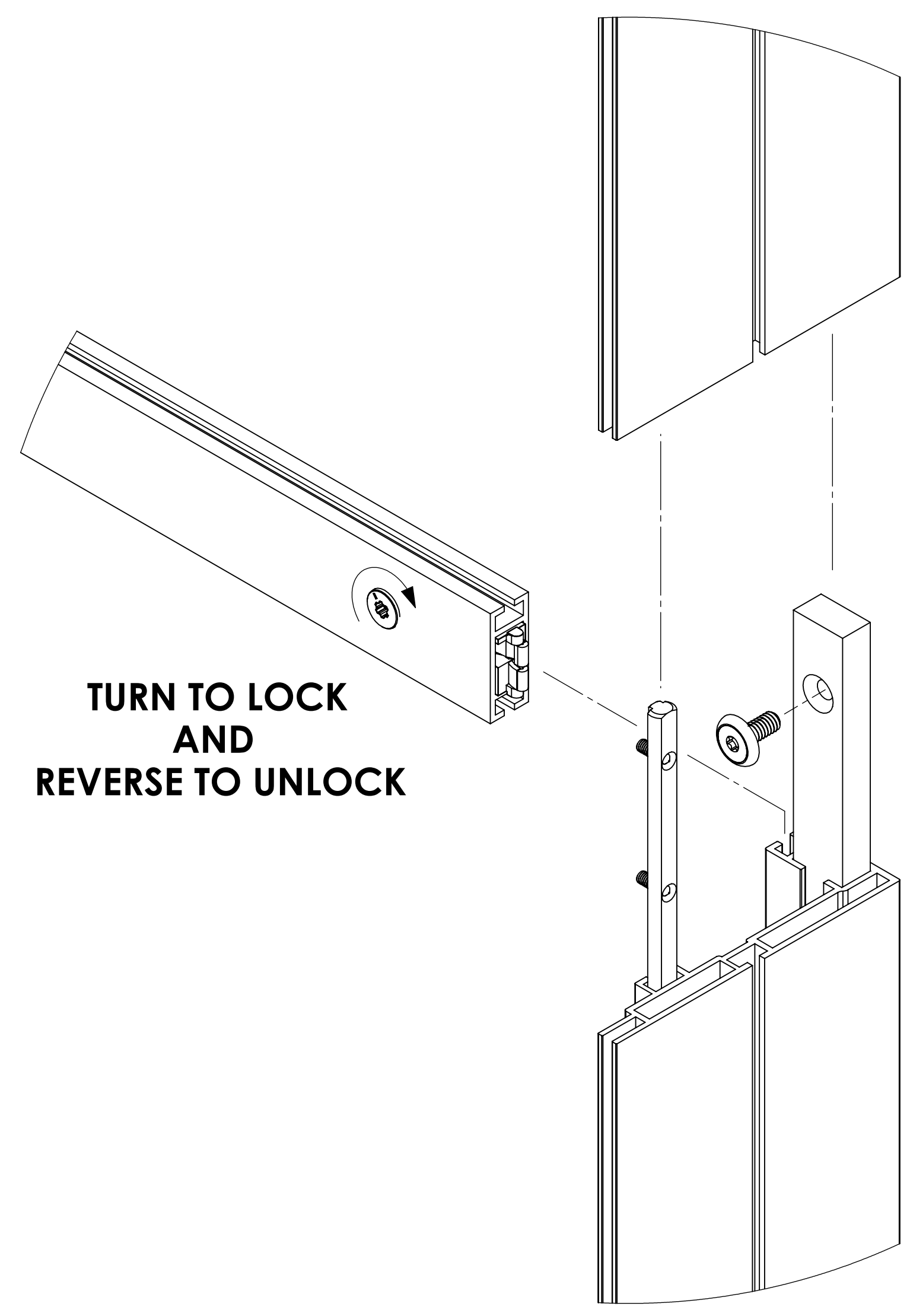
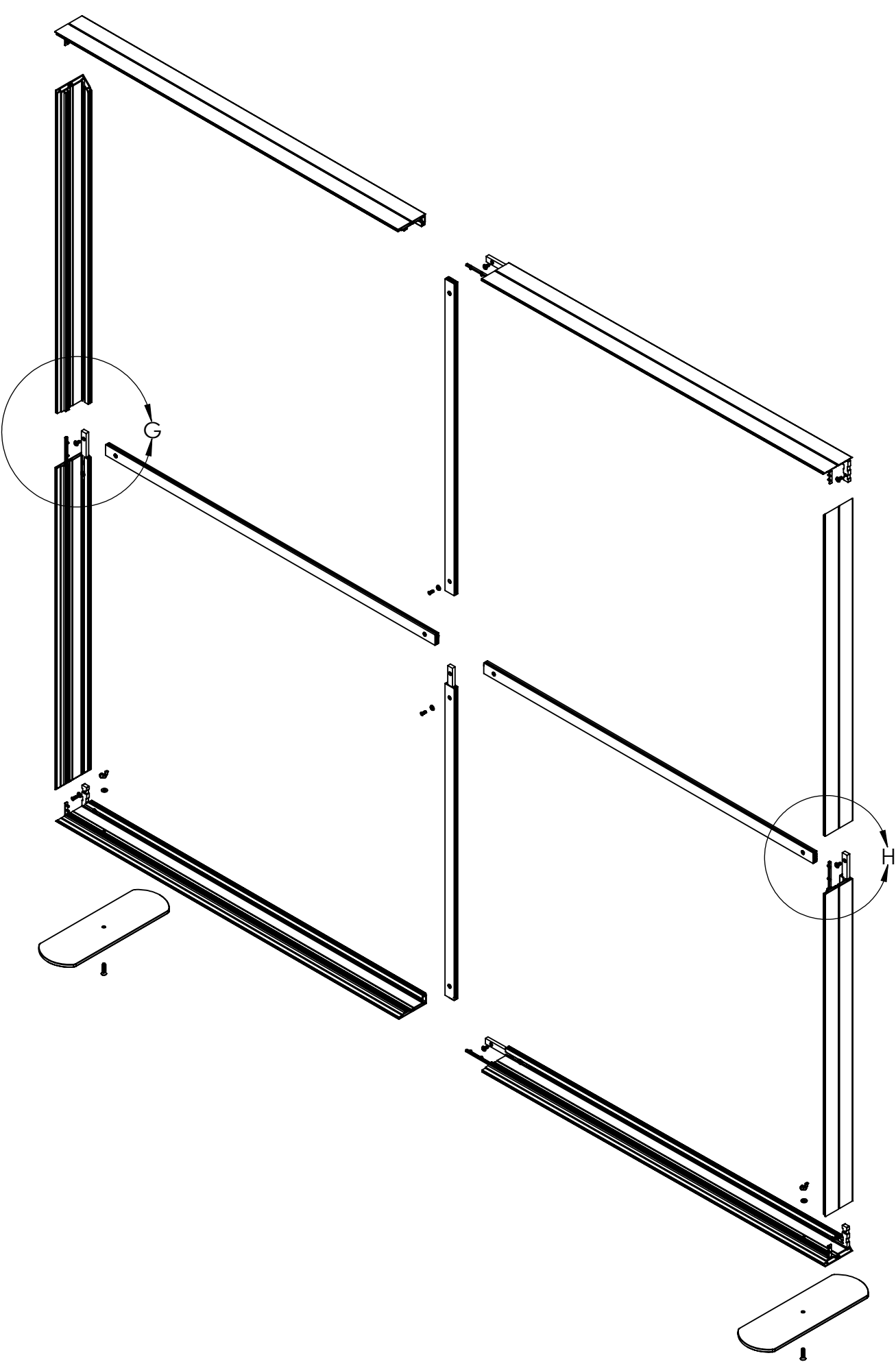

**TURN TO LOCK
AND
REVERSE TO UNLOCK**

DETAIL H
SCALE 3 : 4

8

7

6

5

4

3

2

1



8

7

6

5

4

3

2

1

D

D

C

C

B

B

A

A

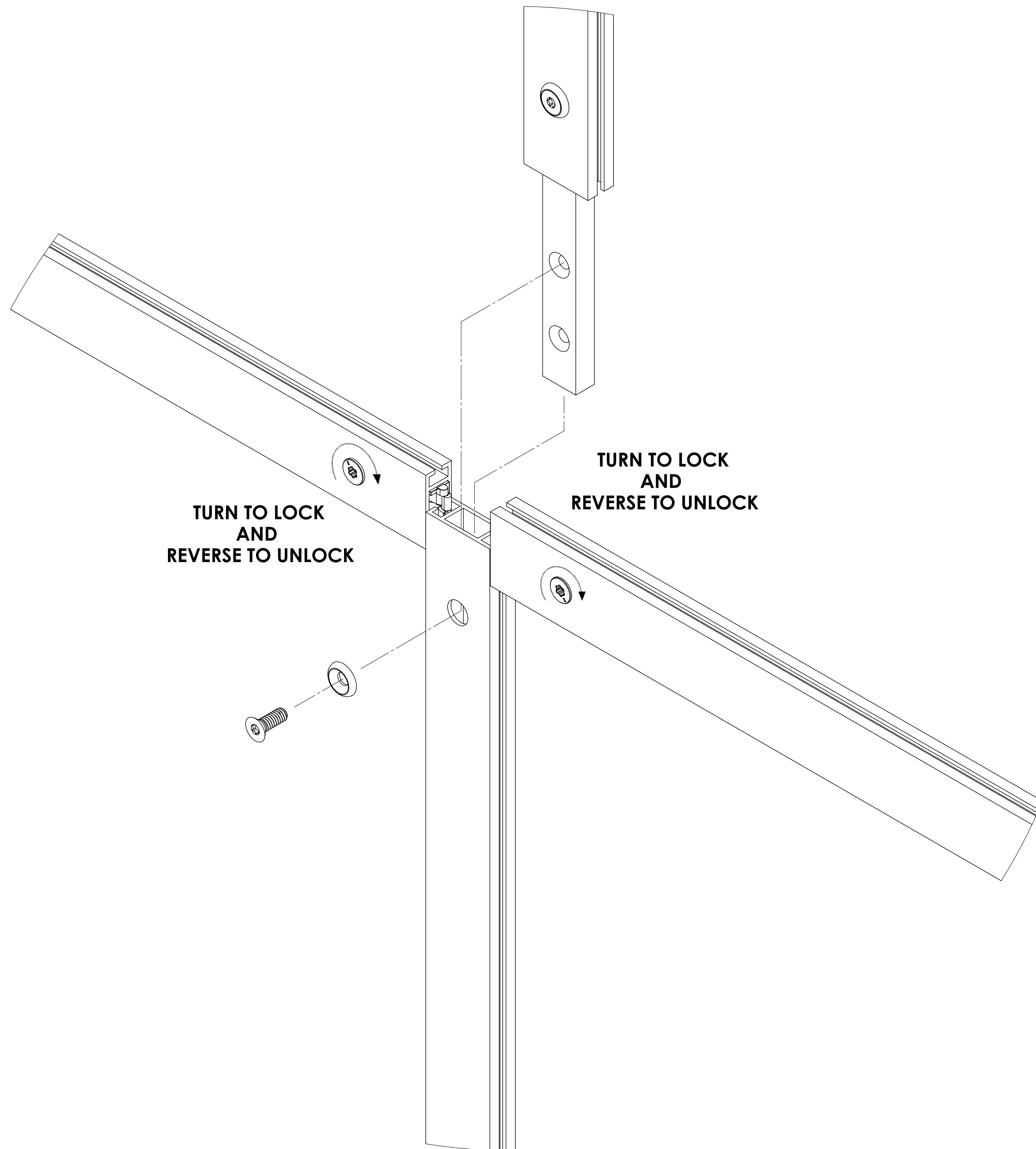

**TURN TO LOCK
AND
REVERSE TO UNLOCK**

**TURN TO LOCK
AND
REVERSE TO UNLOCK**

**DETAIL J
SCALE 1 : 1**

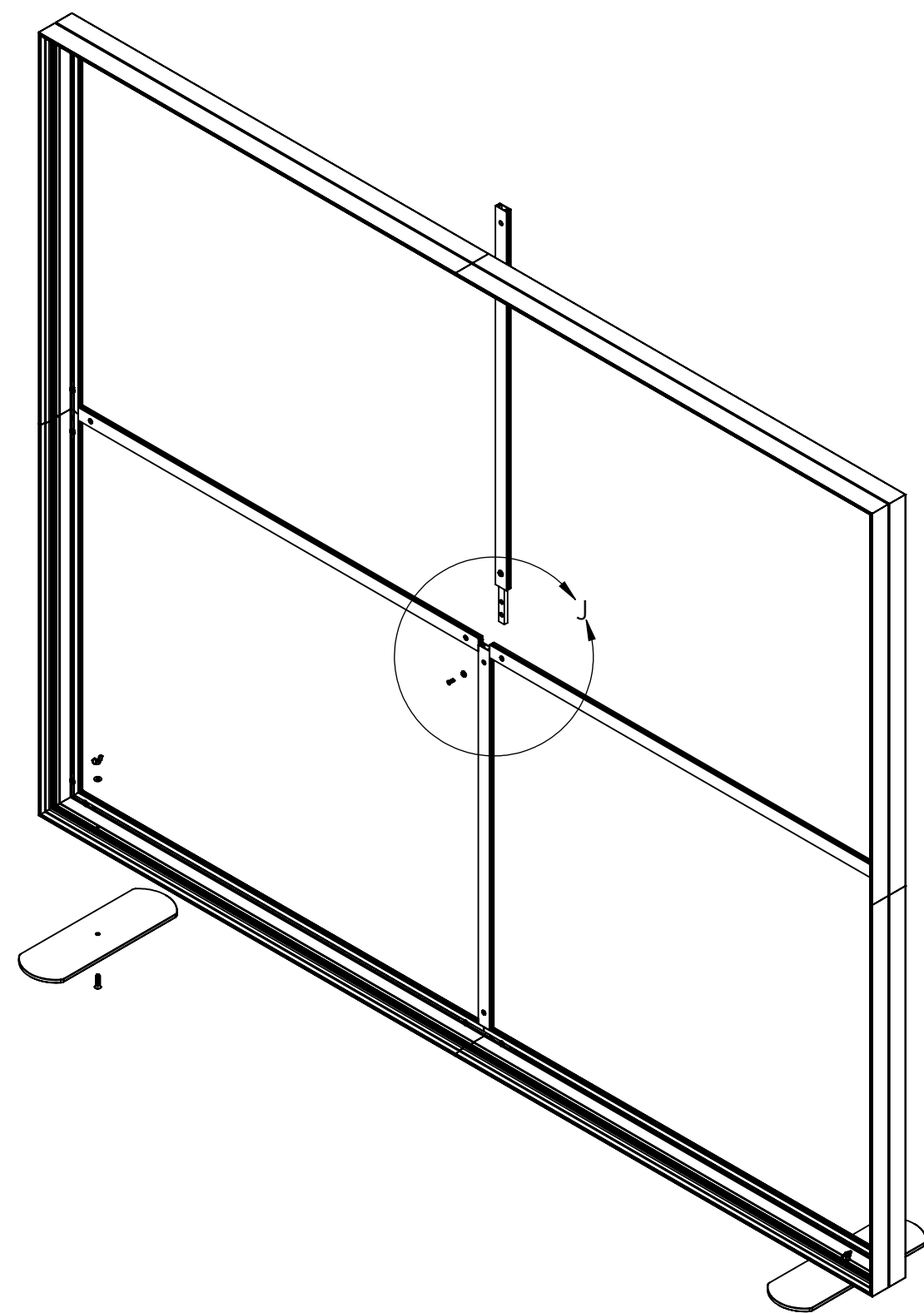

| | | | | |
|--|--|--|--|--|
| | | | | |
| | | | | |

8

7

6

5

4

3

2

8

7

6

5

4

3

2

1

D

D

C

C

B

B

A

A

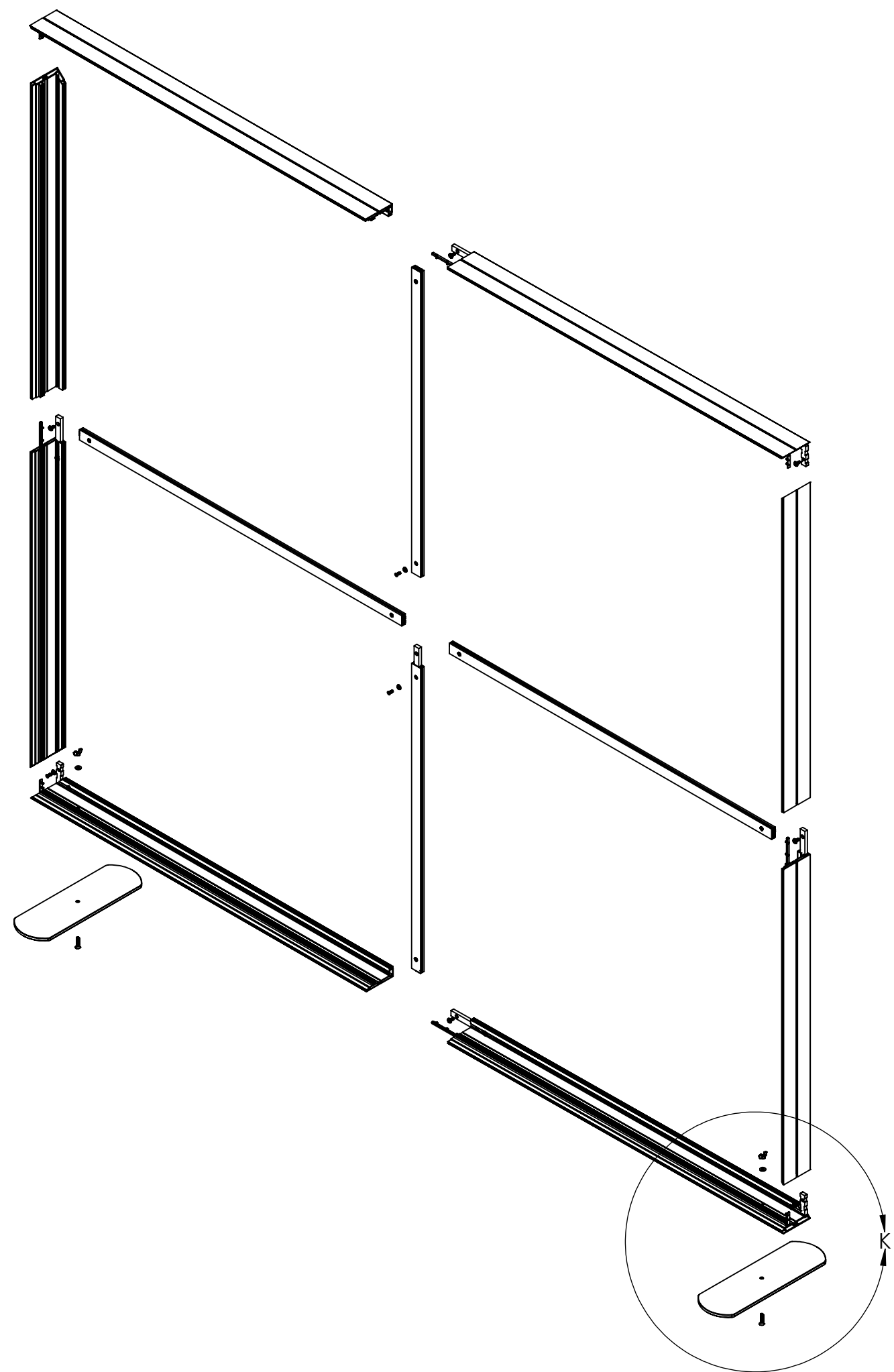
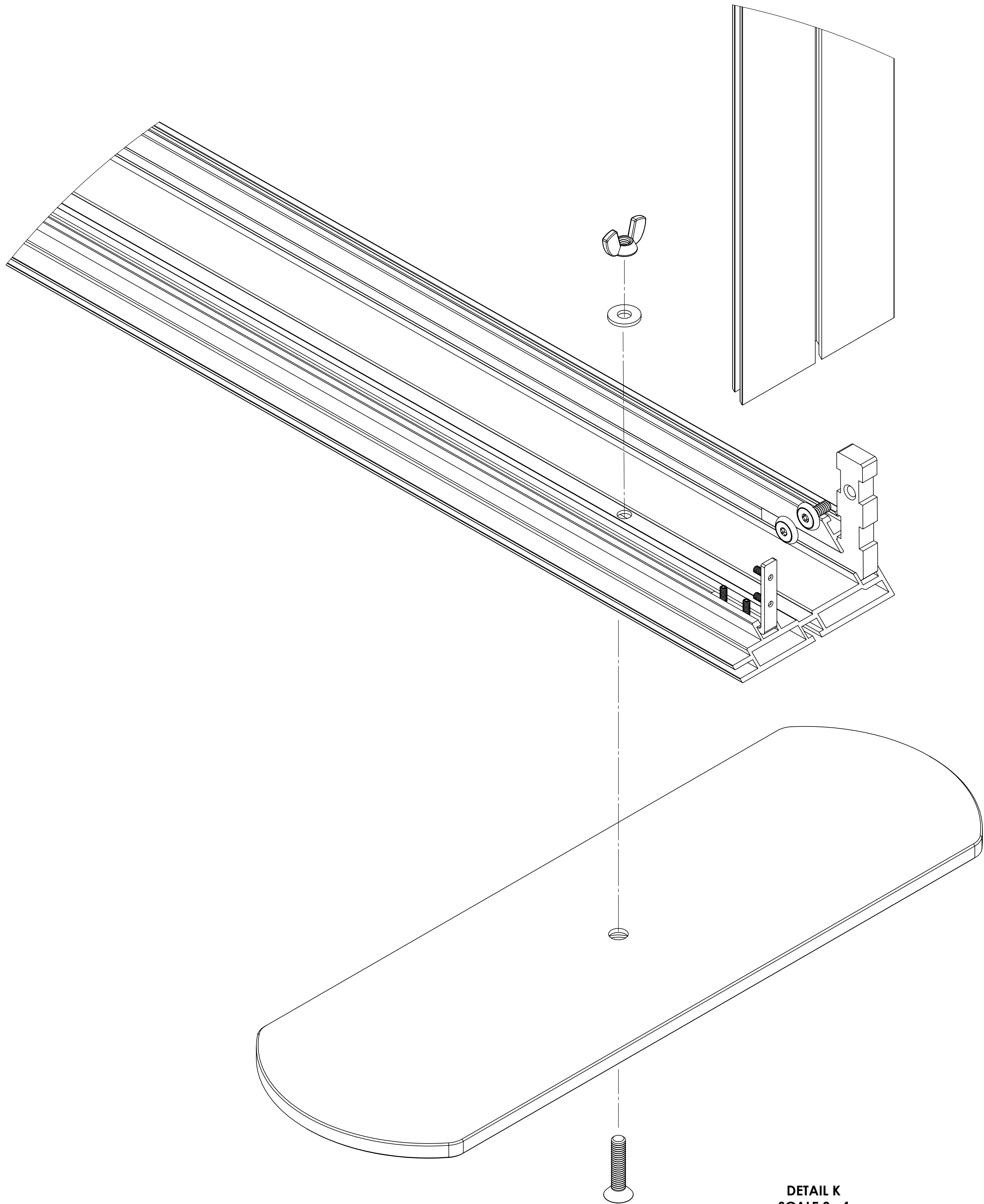

DETAIL K
SCALE 3 : 4

8

7

6

5

4

3

2

1



8

7

6

5

4

3

2

1

D

D

C

C

B

B

A

A

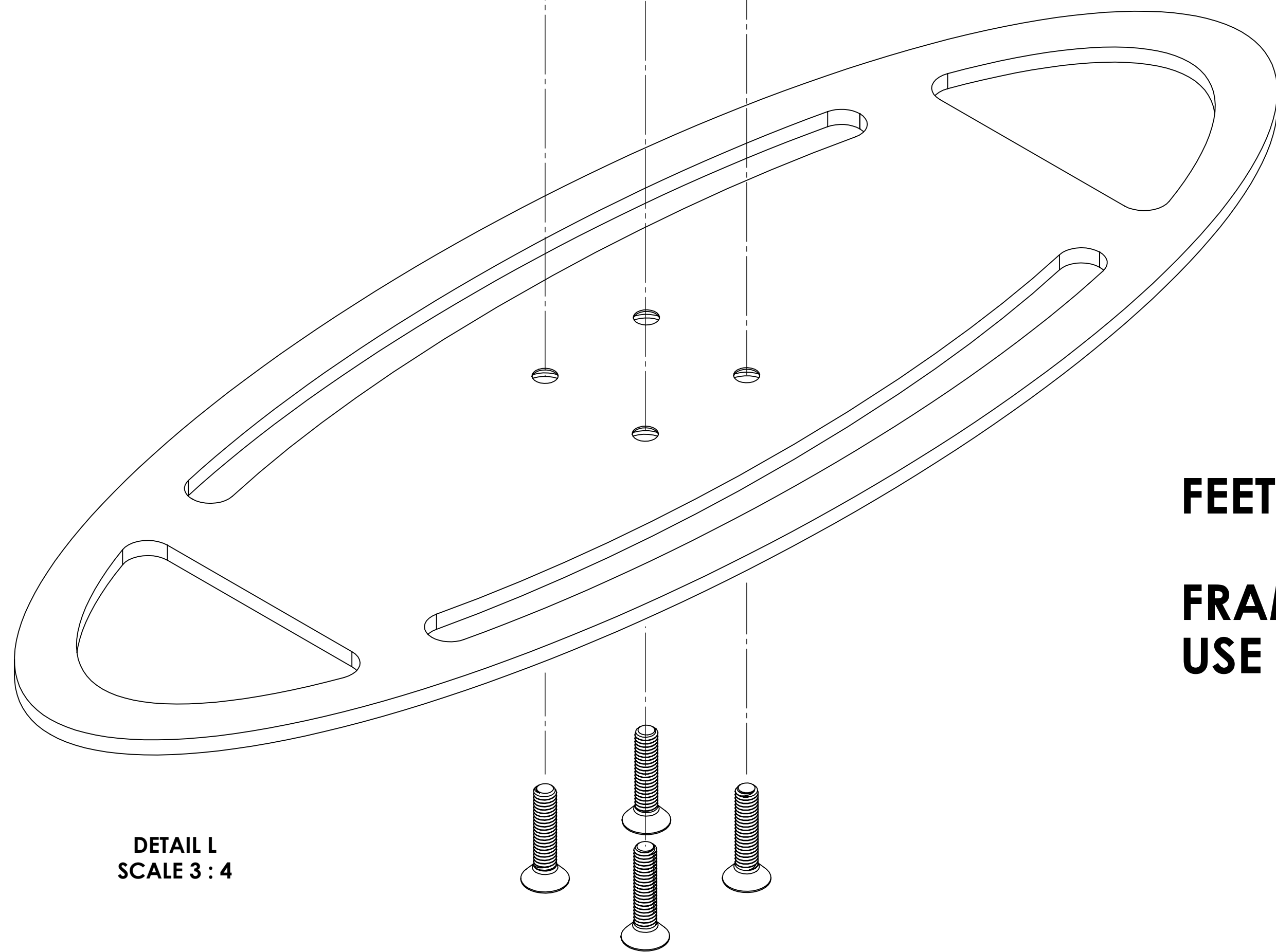
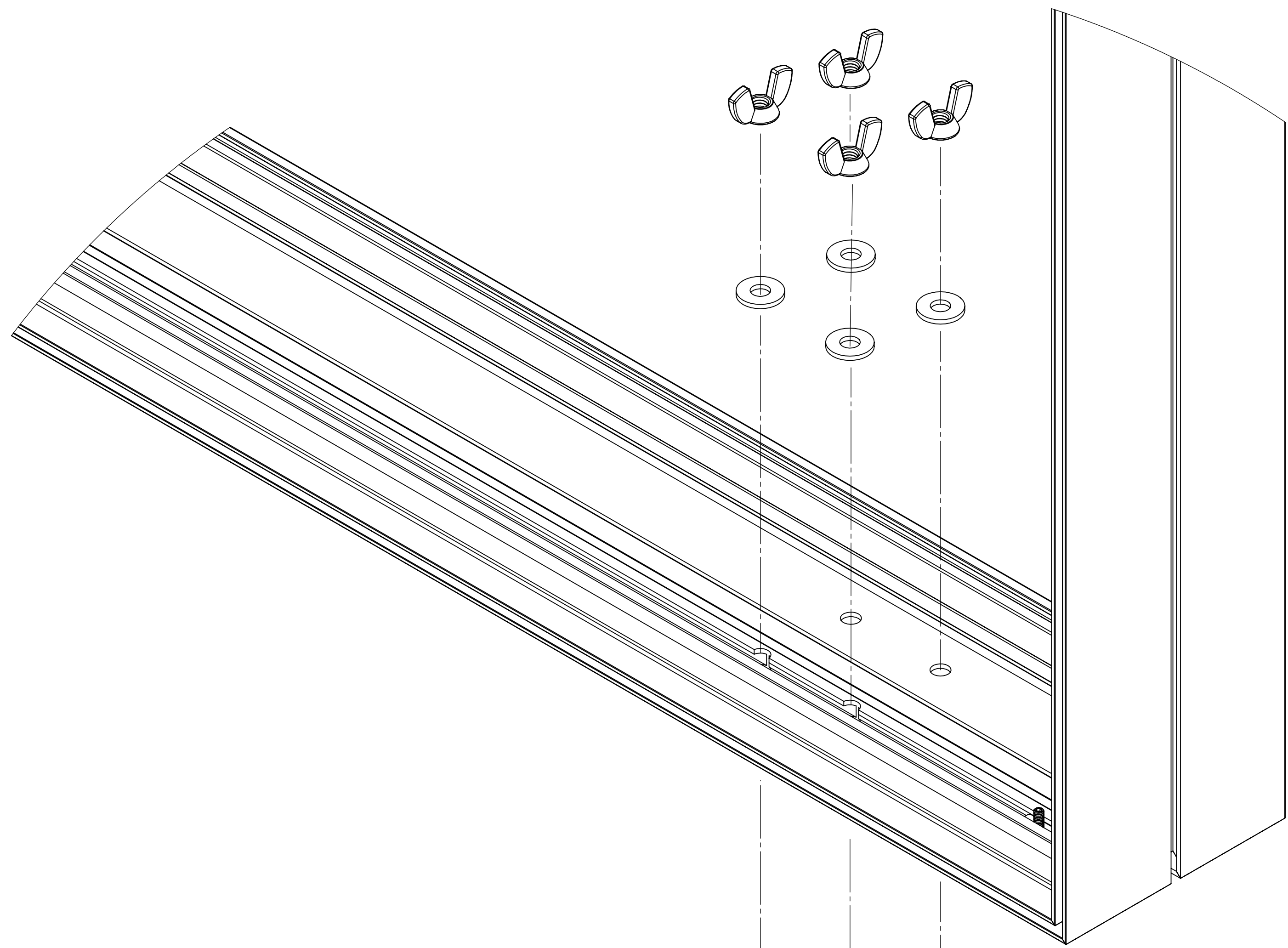
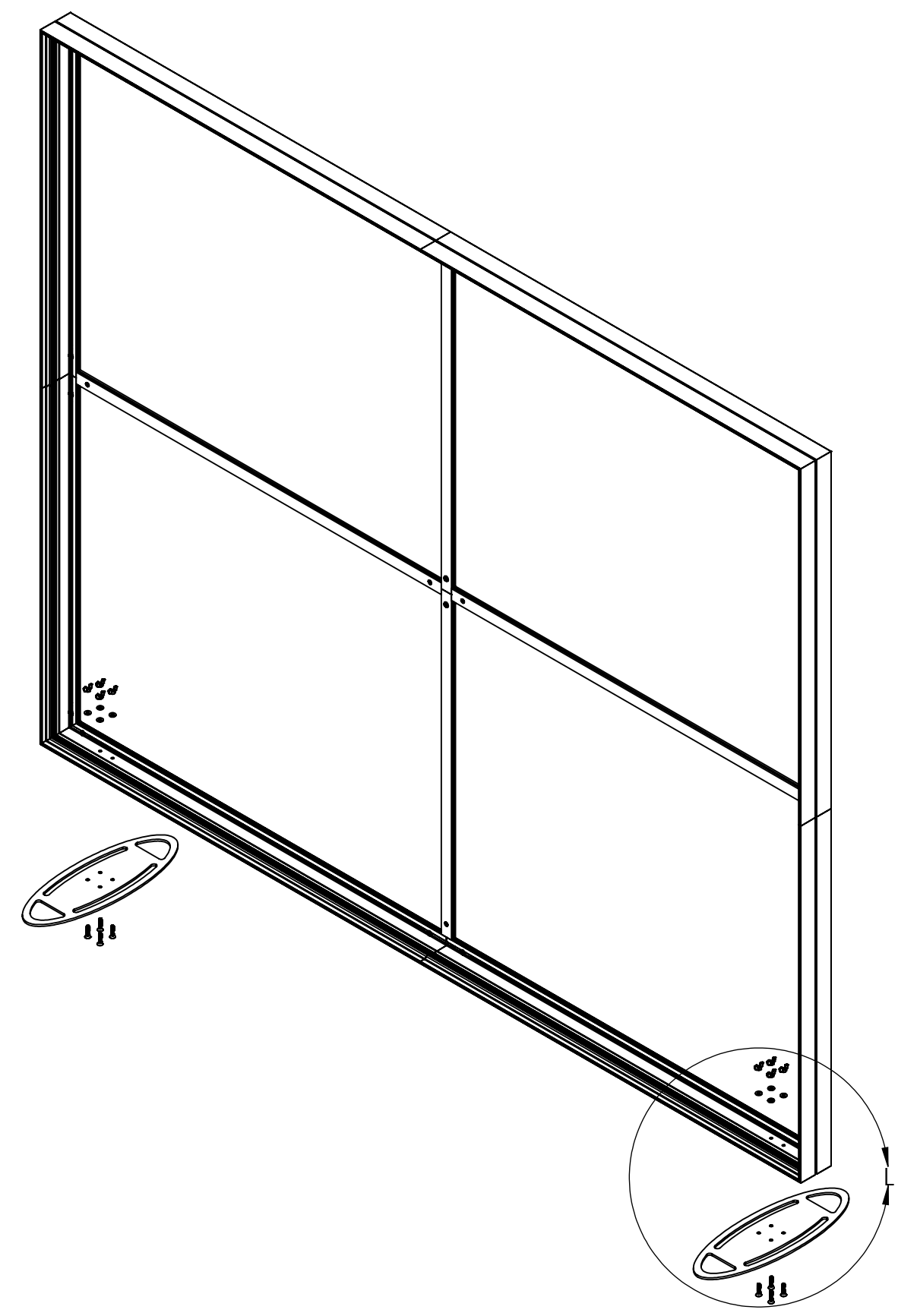

DETAIL L
SCALE 3 : 4

FEET MAY VARY:

**FRAMES LARGER THAN 8 FT. WIDE
USE THESE ELLIPSE FEET.**

8

7

6

5

4

3

2

1



INSIDE TOP VIEW

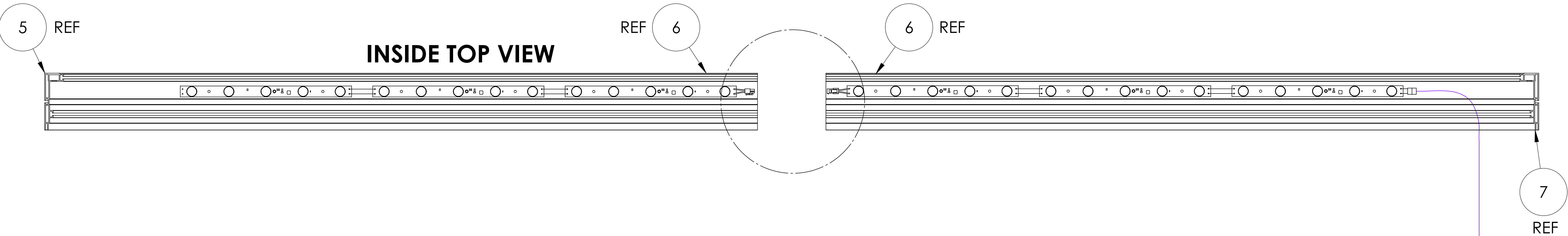

**CONNECT MALE - FEMALE CONNECTORS
(TOP and BOTTOM FRAMES)**

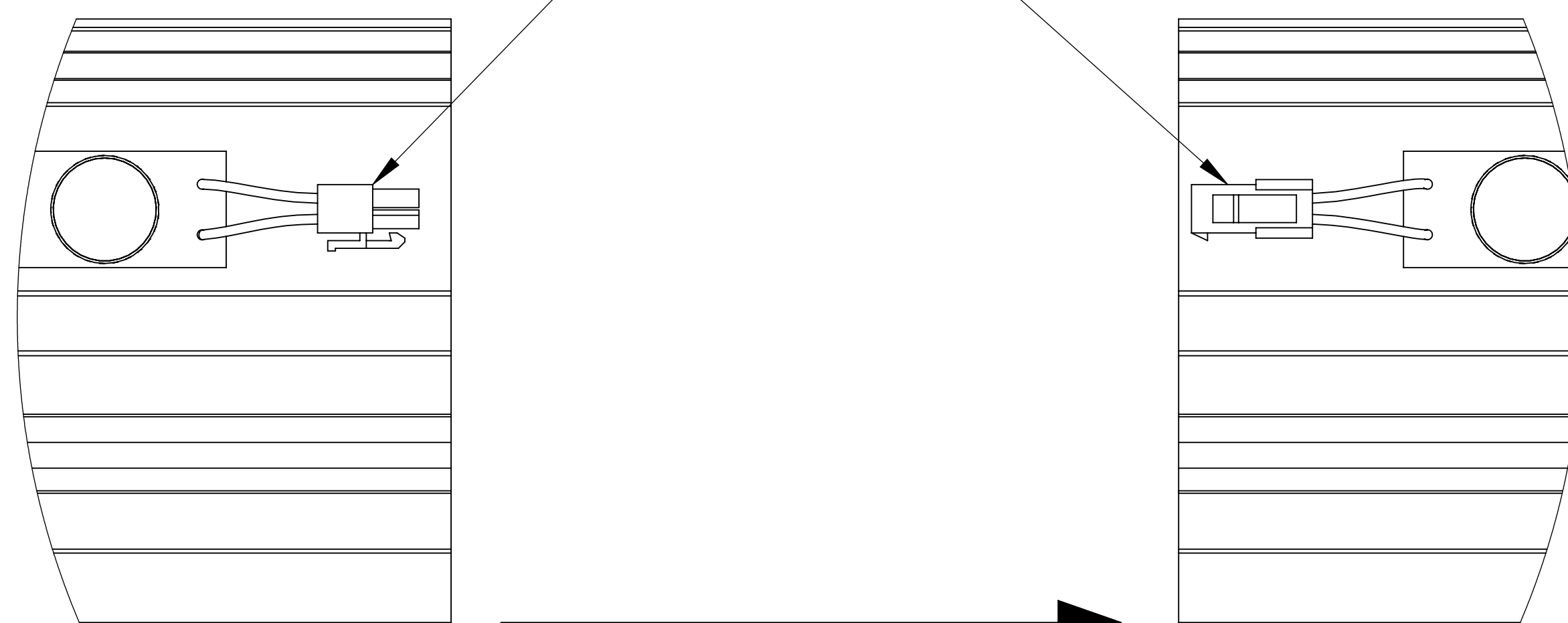

INSIDE BOTTOM VIEW

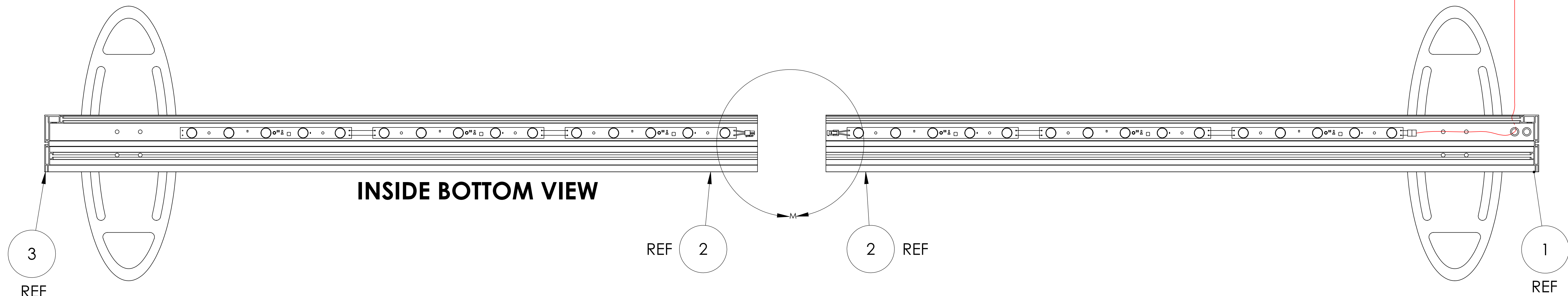

10 FT. LIGHT MODULES CONNECTIONS

Silicone Edge Graphics (SEG)

Installation Instructions into hardware

What are Silicone Edge Graphics (SEG)?

SEG are dye-sublimation fabric graphics with silicone strips sewn along the underside of the fabric's edge. SEG frames have grooves along their perimeter designed to snugly hold the silicone strips so the fabric can be stretched across the frame for a drum-tight fit.



We recommend laying the frame on the floor, then draping the fabric graphic on top.

The following procedure ensures the silicone edge will be placed evenly over the entire frame and NOT STRETCH or GROW at the corners. Once all the edges have been secured, you should have a taut fit with a smooth flat finish.

1: With Clean Hands,

Press SEG silicone edge first, into the corners of the frame.

INCORRECT WAY

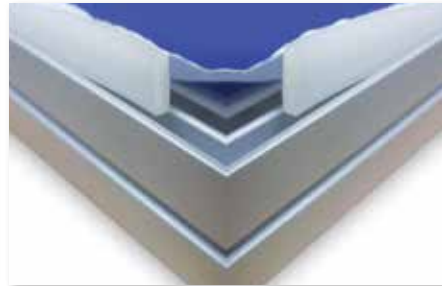

CORRECT WAY

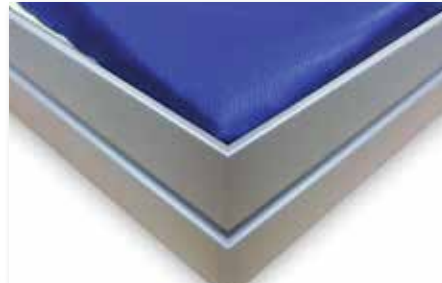

PRESS



Example: 36"x 36" frame

2: Working in Centers.

Go back and press the silicone edge into the center - on each side of the frame.

EXAMPLE: A 20"x20" fabric/frame would be pressed in 8 locations.



PRESS



REVISED 03/2016

Cont'd.

3: Working in Centers again,

Go back and press the silicone edge once again on each side previous center, on all 4 sides.

Repeat this process, (WORKING IN CENTERS) until the SEG fabric's edge is pressed approximately every 6 inches apart.

EXAMPLE: A 8' x 8' frame (using this procedure) will have been pressed/tucked 15 times (not including corners) on each side of the frame.

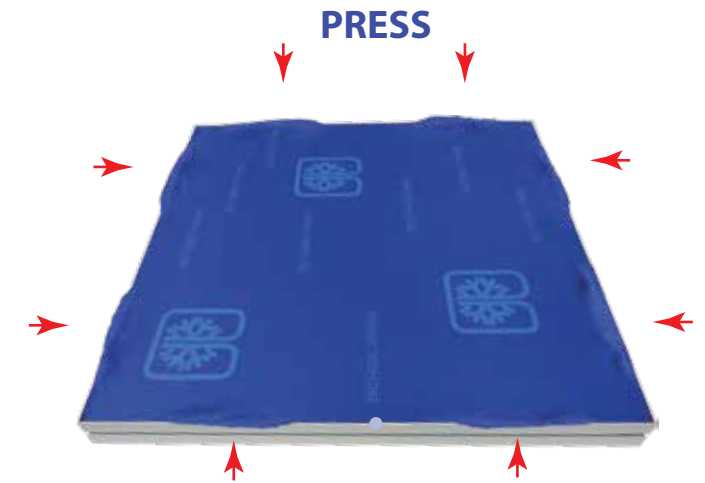
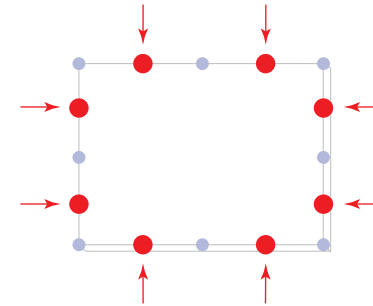

4: After all has been pressed into your frame using

this procedure, lightly tap your forefinger to smooth fabric between the tucks.



CARE INSTRUCTIONS

Due to the fine quality, smoothness and weave of the fabric, great care must be taken to extend the life of your SEG fabric graphics.

We recommend very loosely folding your graphic, making sure there are no hard creases or folds or that the fabric doesn't catch on sharp objects.

Store in a clean bag.

A plastic bag or pillow case is ideal.

Graphics can also be spot cleaned with a damp cloth.

To wash entire graphic, use a commercial size front loading washing machine on gentle cycle with cool water. Do NOT dry clean.

You can also gently iron the back side using the Polyester setting of your iron.



REVISED 04/2016