



## Users Guide and Owner's Manual

THE INFORMATION IN THIS OWNER'S MANUAL IS IMPORTANT TO YOUR SAFETY AND PROPER USE. READ THOROUGHLY BEFORE RIDING FOR THE FIRST TIME.

**Always wear a helmet, it could save your life.**



## WARNING

***Failure to adhere to the directions in this guide could cause serious injury or death. Failure to adhere to the directions in this guide could also stop the bike from working correctly.***

*The information within this guide is vital. It has to be read by every rider prior to riding Phatmoto for the very first time. Always follow the directions and safety instructions outlined within this guide. This guide must stay with the bike when the bike is transferred to some other owner. Don't discard this operator's manual because it has to be reviewed by every rider before their operation of the bike. If a minor is operating the bike, it's the obligation of the minor's guardian to make certain that the minor understands the information within this manual. Phatmoto products aren't intended to be used by minors. Check local law enforcement for bicycle compliance along with all legalities. Legislation will differ from state to state and county to county.*

*This guide includes the most recent product information available prior to printing. You could see the latest version of the operator's guide online at [www.Phatmoto.com](http://www.Phatmoto.com). Thanks to product improvements or manufacturing changes, there may be discrepancies between the information included in this owner's manual and real product specifications. Phatmoto reserves the right to make modifications to its products at any time without any notice and with no obligation to create the exact same or similar modifications to any vehicle previously sold or built.*

## **Congratulations on the purchase of your Phatmoto bike.**

We hope this bike will serve you well for years while having fun and Phat moments. Phatmoto is dedicated to providing you with an exceptional experience. If you are not happy with your bike, don't return it! Instead, contact Phatmoto at (877) 345-3733 or sales@Phatmoto.com, and our customer support team will assist you to the best of our abilities.

**Owning and Operating a Gas Powered Bicycle requires Maintenance and Service**, the information in this manual will be understood best by our customers who are mechanically inclined. If you ever have questions about servicing or maintaining your Phatmoto bike, reach out to Phatmoto customer service for help and assistance. We want to provide the best Ride and customer service experience possible.

**Congratulations again and always wear a HELMET.**

# Table of Contents

Laws and Regulations	4
Safety and Warnings	5
Assembly	7
<b>Installing The Handle Bars</b>	7
<b>Connect the Start/Kill Switch</b>	8
<b>Mount The Front Wheel</b>	8
<b>Adjust Front Brake</b>	8
<b>Install Seat and Post</b>	8
<b>Install the Motor</b>	9
<b>Install the Clutch</b>	9
<b>Connect Jack Shaft to Motor Chain</b>	10
<b>Install the Chain Gear Cover</b>	10
<b>Connect the Throttle Cable</b>	11
<b>Install the Pedals</b>	12
Maintenance Requirements	13
Maintenance Procedures	18
Your First Ride - Starting and Stopping	18
Troubleshooting	20
<b>Motor Will Not Start</b>	20
<b>Motor Not Running Good</b>	21
LIMITED WARRANTY	22
Bicycle Specs	24

# Laws and Regulations

It's the duty of all riders of this Phatmoto to be acquainted with and fully comply with regulations, rules, and regulations governing the operation of the Phatmoto. Laws vary by jurisdiction. Phatmoto does not have any obligation or liability for those expenses to comply with any applicable laws and regulations or to get bike damage or human injury caused by an operator or owner's inability to adhere to all applicable regulations and laws. These laws include, but aren't limited to:

- **Vehicle Operation Laws:** It's illegal to run this off-road bike on public roads, streets, and highways. It's illegal to run this bike under the influence of alcohol or drugs, even on personal property. Other automobile operation laws may apply in your region. Vehicle Title &
- **Registration Laws:** You might want to name or enroll your bicycle with a couple of municipal or state government agencies. You're solely responsible for titling or registering for your Phatmoto and for all associated expenses.
- **Vehicle Modification Laws:** Don't alter your bicycle or join aftermarket accessories. Changes to the carburetor and drainage systems are a breach of this regulation and therefore are subject to prosecution from the Environmental Protection Agency. Modification will void any guarantee covered by Phatmoto.
- **Vehicle Maintenance Laws:** Consistently follow all appropriate vehicle maintenance legislation, including, but aren't restricted to, legislation regulating the disposal and handling of dangerous and flammable materials like gas and oil.

Operating a Motorized bicycle involves some risk of injury. Buyer accepts responsibility for any and all vehicle operation that may lead to personal injury economic loss, social distress, other losses, costs and damages.

# Safety and Warnings

The Phatmoto bicycle has the capability to cause severe harm or death. Even though the dangers related to riding a motorized bike can never be removed entirely, following all of the directions found in this guide will decrease the possibility of injury to the operator as well as others. Any riders of this Phatmoto bike must always review and adhere to the directions outlined within this guide. It's not feasible to warn the motorized bike operator or owner of all probable dangers related to operating and maintaining a Phatmoto. All operators need to exercise good judgment in operating and maintaining the motorized bicycle. Phatmoto does not have any obligation or liability for motorized bike injury or personal injury caused by an owner or operator failure to safely operate or service the bikes.

- **WARNING:** Never let children under the age of 18 to ride the Phatmoto bike. The Phatmoto is intended for riders that are 18 or older. Riders younger than age 18 shouldn't operate the motorized bike.
- **WARNING:** Never let unsupervised or unqualified minors to ride on the bike. If the operator of the Phatmoto is a minor, the rider's protector is responsible 1) for making sure the rider matches the physical and developmental levels required to safely ride the bicycle and two ) for supervising the little while he or she's riding the motorized bike.
- **WARNING:** Always wear protective safety gear whilst riding the Phatmoto. Protective safety equipment includes, but is not restricted to, a Department of Transportation approved ab bike helmet with a chin strap, goggles, gloves, boots, long riding pants with hip and knee pads, and a long sleeved riding jersey using chest, elbow, and shoulder pads.
- **WARNING:** Always guard hair whilst riding the motorized bicycle. Loose hair has the potential to get caught in the Phatmoto. Always maintain hair tightly fastened while operating the bike.
- **WARNING:** Never operate the bike under the influence of alcohol or drugs. The usage of drugs or alcohol will inhibit the rider's capacity to security operate the motorized bicycle.
- **WARNING:** Never run the Phatmoto with a passenger. The Phatmoto bike was created for one rider at a time.
- **WARNING:** Never ride the Phatmoto bike at night. The bicycle is not equipped with lighting.
  
- **WARNING:** Never ride the Phatmoto bicycle if it isn't in proper riding state. Always inspect your aerodynamic bike before you journey to be certain it is in appropriate riding state. In case you have any sign, your aerodynamic bike isn't functioning properly, quit riding instantly. Locate another procedure of transport. As soon as you're back to security, check with the Maintenance Procedures and Troubleshooting sections of the manual to support your aerodynamic bike.
- **WARNING:** Always practice good judgment whilst riding on the Phatmoto bike. It's the obligation of the owner of the motorized bike to utilize sound judgment in the

performance and application of the motor vehicle. Ride within your ability level at rates that are comfortable. Be wary of possible dangers and hard terrain. Exercise extra care in wet or muddy riding conditions. Always keep both feet and hands onto the handlebars and pedals. Don't brake or speed while turning. Don't try suggestions or stunts or move off jumps.

- **WARNING:** Never run the Phatmoto within an enclosed area with inadequate ventilation. The motorized bikes exhaust gas includes poisonous carbon dioxide that can collect rapidly in an enclosed region and cause death or illness. **WARNING:** Never alter the Phatmoto or join aftermarket accessories. Modifications and after-market accessories decrease the rider's capacity to ride and control the aerodynamic bike securely. Phatmoto isn't responsible for any harm or harm due to any accessory.
- **WARNING:** Always execute the essential maintenance on your car or truck. Attempting to do essential maintenance on your vehicle could lead to harm or deadly injury to the operator or other people.
- **WARNING:** Always exercise caution whilst still servicing the Phatmoto bike. Doing most maintenance processes on the aerodynamic bike entails handling potentially harmful and flammable materials like oil and gas. Recognize the threat that harm could potentially happen as you're servicing your Phatmoto and consistently use good judgment. Wear the required protective equipment. Keep cigarettes and fires from your Phatmoto. If you're uncomfortable with all the risks, consult with a Licensed Phatmoto Service Center to execute maintenance activities for you.
- **WARNING:** Never do maintenance on the automobile whenever it's running. To decrease the probability of potential injury or burns from hot or moving parts, constantly make certain that the motor stop button and the gas valve lever will be equally at the off position prior to doing maintenance on your own aerodynamic bike. Never touch any one of those Phatmoto components while the aerodynamic bike is operating.
- **WARNING:** Always wash hands after handling the Phatmoto. Certain elements of the item and bundle contain chemicals known to the State of California to cause cancer, birth defects, or other reproductive harm.

# Assembly

Now that your Phatmoto is here, let's put this bad dude together. Phatmoto recommends a professional assemble and check your motorized bicycle.

First remove the Phatmoto from the box and remove all zip ties and plastic protective packaging.

## Installing The Handle Bars

Handlebars are secured to the bike by the stem. Remove only the 4 Stem bolts and remove cap and Shims (if included). Center the bars on the stem, adjust the angle of the bars for comfort and secure them with the Shims, Top Cap and 4 bolts. Make sure the cables are not tangled or twisted.

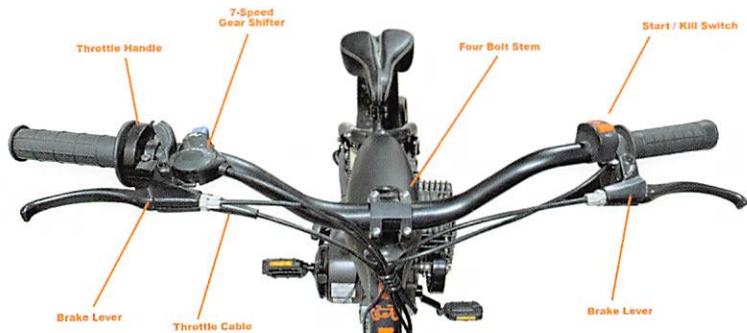



### **Connect the Start/Kill Switch**

The Kill switch will have 2 wires that come off the unit on the handlebars (see Picture). The Black wire with the eyelet goes under the ground bolt on the motor. The green wire connects to the wire on the motor.

### **Mount The Front Wheel**

Place front wheel on fork, use caution to not damage the disk. The disk should slide in the middle of the 2 pads on the caliper. Align the lock washer notch with the hole on the fork. Tighten the nuts using a 15mm wrench. Make sure bolts are nice and tight before moving the bike.

### **Adjust Front Brake**

Lift the front wheel off the ground and give it a spin, if you hear contact of the pads with the disk, then it must be adjusted. The caliper has 2 screws securing it, when loosened the caliper can be moved slightly in and out or angled. Move till no noise is heard when wheel is spun, tighten the 2 bolts back. Additional slack can be taken out of the cable or at the adjuster barrels at the caliper and handle.

### **Install Seat and Post**

Attach the seat to the post and tighten. Mount the post to the frame, move to desired height and tighten seat post clamp bolts. Seat angle position can be adjusted by loosening the seat, adjusting to desired angle and locking down the nuts.

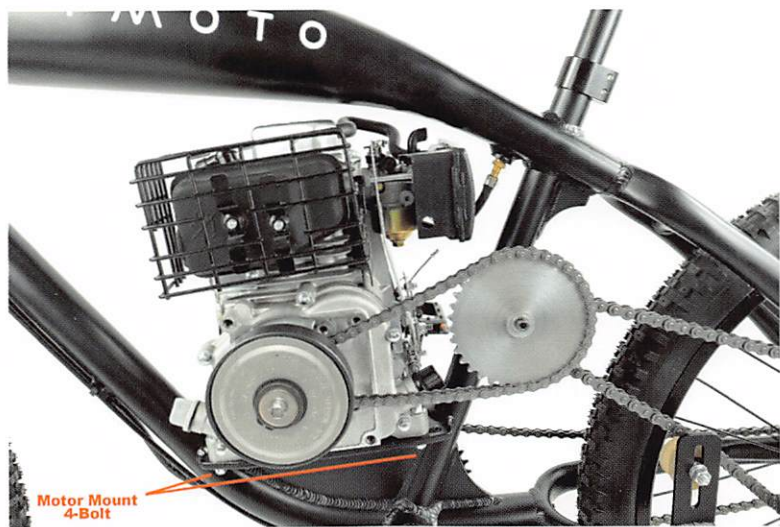

### **Install the Motor**

Locate the 4 motor bolts to secure the motor to the frame. When installing the motor on the bike, make sure the output shaft is on the bikes left side (see picture). Do not tighten the bolts all the way yet, after the chain to the jack shaft is installed.

### **Install the Clutch**

Rotate motor so the keyway is facing up. Locate the keyed opening on the clutch pack (see Picture), place on the shaft. Secure the clutch with the bolts and washers.

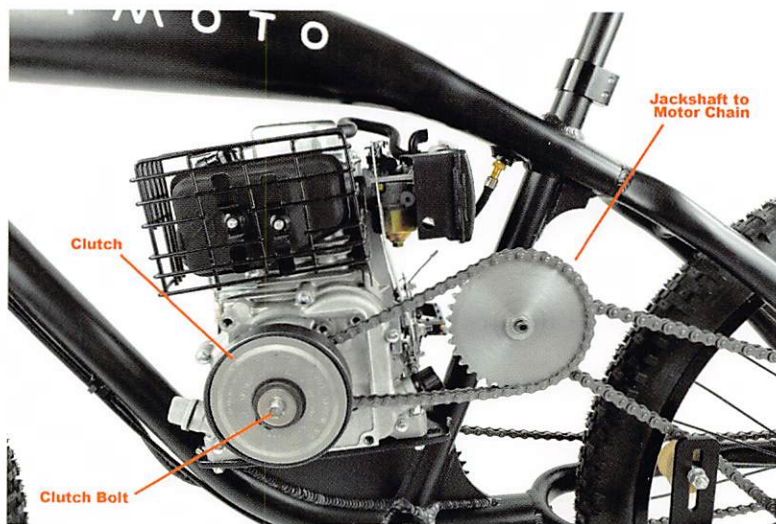

### **Connect Jack Shaft to Motor Chain**

The 35 chain that connects the clutch off the motor to the jackshaft is already cut to size. Remove master link and wrap the chain around the clutch 11 tooth gear and the large jackshaft gear. Reinstall the 35 master link. Now with the motor still loose, slide the motor forward to remove excess slack from the chain. Now tighten the motor down to the frame.

### **Install the Chain Gear Cover**

Mount the chain gear / Jackshaft cover with the 3 Studs and nuts. To verify the cover was installed correctly, roll the bike forward and back to listen for sounds of anything rubbing the cover.

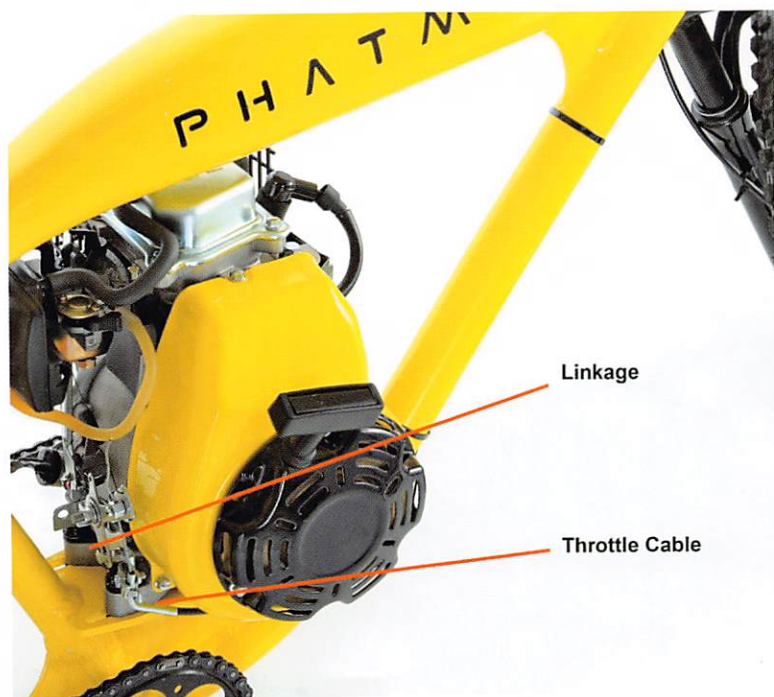

### **Connect the Throttle Cable**

Route the throttle cable from the handle to the left, use the cable notch holders on the frame to secure. Make sure not to bend or kink the cable, damaging the cable or housing may cause it to not work smoothly. Run the cable through the second frame holder and up to the motor. The silver J bend will clamp to the motor just below the throttle on the motor. Now thread the inner wire through the cable lock on the throttle, Remove any access play, not too much so the throttle opens up. Screw it in to lock the wire in.

## **Install the Pedals**

The pedals will have a R or a L stamped on them, they indicate which foot will touch it when seated on the bike. Screw the Right pedal on the the side where your right foot would be, use a 15mm Wrench to tighten. Pedals will always screw in a forward direction. Do the same with the left on the left side.

# Maintenance Requirements

Maintenance needs are a standard part of owning and operating a motorized bicycle. The operator of this Phatmoto is accountable for correctly maintaining the motorized bicycle and also for understanding if and how the motorized bicycle has to be serviced. The precise time when maintenance procedures have to be done will vary depending on the kind of upkeep, riding conditions, and driving frequency. The care procedures outlined {in|within} this guide are only instructions for how and when to carry out standard maintenance procedures. Apart from the procedures mentioned within this guide, there are lots of other more complex maintenance processes which will have to be carried out on your own Phatmoto throughout your ownership of the bike. Failure to properly maintain your Phatmoto could stop the motorized bicycle from working properly and may also cause harm or deadly injury to the rider or others. Phatmoto does not have any responsibility or liability for those costs to properly keep the bikes (unless specifically covered by warranty) or for motorized bicycle damage or human injury caused by an operator or operator's inability to service and keep the Phatmoto correctly.

**For more details on maintaining the motor, please refer to the motor user's manual.**



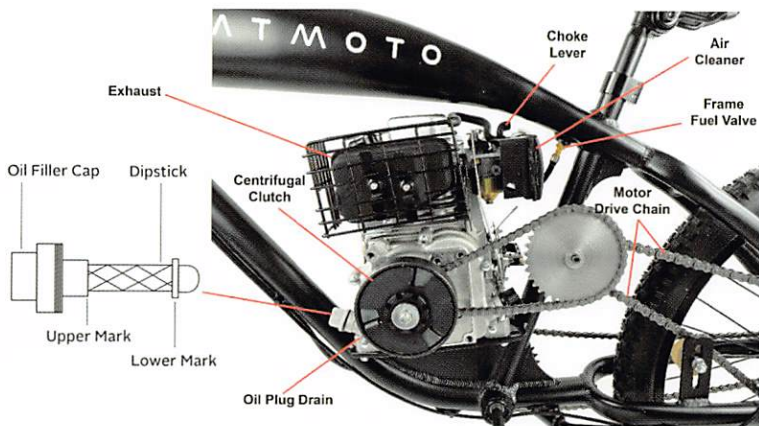

### **Maintenance Schedule**

Scheduled inspection and adjustment of the motor is essential if a high level of performance is to be maintained. Regular maintenance will also provide a long service life and help maintain vehicle safety. The required service intervals and the kind of maintenance to be performed are described in the tables below.

**For more details on maintaining the motor, please refer to the motor user's manual.**





# WARNING

- Shut off the motor before performing any maintenance.
- To prevent accidental start up, turn off the motor switch, Fuel Valve and disconnect the spark plug.
- The motor should be serviced by your dealer unless the owner has proper tools and service data and is mechanically qualified.

<b>Maintenance Schedule</b>					
<b>Task</b>	<b>Every Use</b>	<b>1st 20 Hours 1 Month</b>	<b>Every 50 Hours 3 Months</b>	<b>Every 100 Hours 6 Months</b>	<b>Every 300 Hours Yearly</b>
Check Fuel Level	X				
Check Oil	X				
Check/Lube Chain	X				
Check all Bolts for Tightness	X				
Check Brakes	X				
Check Throttle	X				

## Maintenance Schedule

Task	Every Use	1st 20 Hours 1 Month	Every 50 Hours 3 Months	Every 100 Hours 6 Months	Every 300 Hours Yearly
Change Motor Oil		X		X	
Check Air Cleaner	X				
Clean Air Cleaner			X		
Replace Air Cleaner					X
Check Spark Plug Gap / Clean				X	
Replace Spark Plug					X
Change Fuel Filter / Clean Tank					X
Fuel Supply Line					X
Clean Deposit Cup			X	X	

# Maintenance Procedures

## Your First Ride - Starting and Stopping

Now here comes the really fun part, but before you get the wind in your face, there is a couple of safety checks first.

### Getting your Phatmoto ready to ride

1. Check the bike over thoroughly, look for loose bolts, nuts, damage, proper tire inflation, tight handlebars. It's always a good idea to pedal the bike around for a little bit to make sure the steering and brakes function properly.
2. Make sure fuel and oil is at operating levels (see fuel and oil section)
3. Wear proper safety gear (D.O.T approved helmet, proper footwear, eye protection, ect.). Wear proper clothing that would protect you against any mishap.

### Breaking in your Phatmoto

To prolong and protect your new motor, break in your Phatmoto. This means to take it easy on it for the first 20 miles. Avoid using full throttle and starting from a dead start, pedal a little at first, then gas it. This will allow your motor to break in and extend its life.

### Starting your Phatmoto

After performing you complete bike inspection and putting on your safety gear, it's time to ride.

1. Push the start button to the Start position.
2. Slide the Choke lever to the Start position.
3. Make sure both fuel valves are open, one on the frame and one on the motor.
4. Using the pull start, in a smooth motion, Pull the ripcord multiple times till the motor fires.
5. Slide the choke to the run position

### **Riding your Phatmoto**

The Phatmoto rides like a bicycle, rider must be able to ride and balance a bicycle.

#### **To Go**

Use the right hand twist throttle to accelerate, let off the throttle to slow down. Twist toward the rider to give it gas, the opposite to decelerate. Just like most motorcycles or scooters. It's a good idea to pedal a little before taking off. Keep your feet on the pedals whenever the bike is in motion. Make sure they are square on the pedals.

#### **To Stop**

Let off the throttle or twist it away from the rider (forward) and at the same time apply the hand brakes. Using both brakes at the same time will make the bike stop sooner. The more pressure is applied the harder the brakes will make you stop. Remember to let off the gas at the same time, it will not stop if you are still giving it gas. When you come to a complete stop put down your feet to not fall over.

# Troubleshooting

If you are having issues with your Phatmoto, please refer to the troubleshooting steps below. If you have completed all of the troubleshooting steps and your motorized bicycle is still not running properly, contact Phatmoto at (877) 354-3733 or sales@Phatmoto.com or take your motorized bicycle to an Authorized Phatmoto Service Center. Remember, always feel free to contact Phatmoto customer service with any questions and our customer support team will assist you to the best of our abilities.

## Motor Will Not Start

<b>Problem</b>	<b>Solution</b>
Motor Fuel Shut Off Valve Closed	Open Fuel Valve to let fuel into carburetor.
Frame Fuel Shut Off Valve Closed	Open Fuel Valve to let fuel into carburetor.
Out of Gas	Add Fuel to Tank (see Maintenance/ Fluids)
Start / Kill switch wire is disconnected	Make sure the 2 wires are connected. Black to ground on motor, green to the motor.
Motor Start / Kill Switch is Off	Push the Start / Kill switch button to the start position.
Choke in the Run Position	Move choke lever to the Start position, start motor then switch to the run position.
Spark Plug or Wire Damaged or Disconnected	Plug wire back on spark plug, if damaged it would need to be replaced. Call customer service for support.

## Motor Not Running Good

<b>Problem</b>	<b>Solution</b>
Choke lever in the Start Position	Slide choke lever to Run position, Start only used while starting.
Incorrect oil level	Check oil level. (see adding Fluids)
Poor or Contaminated fuel	If bad gas is in the tank, it must be drained. No oils or fuel additives are required. Use only fresh gas.
Low Tire Pressure	Inflate tires to suggested P.S.I that is written on the tire itself. Never over inflate
Dirty Air Filter	Air filter can be serviced and cleaned.
Fuel Valves not fully open	Make sure both valves are open all the way
Spark Plug Fouled or Gap issue	Check plug to see if it is fouled or needs to be re-gaped.

# LIMITED WARRANTY

## WHAT IS COVERED

Phatmoto warrants only to the first retail buyer of this product that this item is absolutely free of defects in workmanship or material flaws for a period of ninety (90) days from the date of purchase. At Phatmoto's sole discretion, Phatmoto intends to either fix, offer replacement components for, or replace free of charge, any item or part with a material flaw, except as limited below. Phatmoto will require the buyer to return to Phatmoto, at the buyer's cost, the component (s) or product component(s) claimed to be faulty for Phatmoto's review and sole determination of flaw. At that moment, the returned component (s) or product part (s) become the property of Phatmoto and won't be returned. This item can also be covered with an Emissions Control System Warranty that is separate from and in addition to this warranty.

## WHAT IS NOT COVERED

This warranty doesn't cover any damaged or broken parts brought on by abuse, neglect, negligence, accident, or procedure in any way contrary to the directions found in the user's guide and owner's manual. Damage to the product caused by ordinary wear and tear, modification or alteration of this item, improper or insufficient maintenance, use of unauthorized replacement parts, or service supplied by anyone aside from an Authorized Phatmoto Service Center isn't covered under this warranty. This warranty doesn't cover minor surface defects, tears, rips, or other cosmetic damages as a result of regular usage, or because of intentional or accidental damage to this item. This limited warranty won't cover any damage that results from the use of improper cleansers, solvents, or chemicals to this item, from smoke or soot, or by exposure to saltwater, sea wind, or sodium. This limited warranty won't cover any damage caused by keeping the merchandise with vulnerability to the elements. Without limiting the above, this warranty is void with regard to any item which has sustained damage caused by accidents, impacts, or applications recognized by Phatmoto to be outside of the range of regular and secure operation, such as, but not limited to, performing tricks, stunts, or even jumping.

## **LIMITATIONS OF LIABILITY**

This warranty is non-transferable following the product's original sale. Any unapproved alterations to this product or its functionality will void this limited warranty. This warranty doesn't cover products used for rental or business purposes, nor does this cover Phatmos used in contests or competition. This limited warranty covers only the price of replacing and/or fixing components that have a manufacturer's defect in workmanship or material. This warranty doesn't cover the price of transport, towing, missing time, hassle, or any incidental or consequential damages of any sort. This limited warranty doesn't cover costs caused by improper repairs or even misdiagnosis of issues. Except with regard to the emissions control system warranty required by the Environmental Protection Agency, Phatmoto makes no other warranty of any kind, implied or express. All implied warranties of functionality and fitness for a specific purpose which exceed the responsibilities and time limits mentioned in this warranty are disclaimed and excluded by this warranty. You might have different or additional rights under your state's regulations.

## **OWNER'S RESPONSIBILITIES**

As the motorized bicycle owner, you're accountable for ensuring all necessary maintenance is done on your merchandise. You're also responsible for keeping a record of and all receipts for maintenance done on your merchandise. Your warranty claim might be denied solely on account of your failure to guarantee the completion of all scheduled maintenance or maintain the maintenance receipts or records.

## **KEEP YOUR RECEIPT**

*Proof of purchase will be necessary to substantiate any warranty claim. Since the motorized bicycle owner, warranty coverage could be refused if your Phatmoto or among its components has failed due to misuse, neglect, and improper care, or unapproved alterations.*



# Bicycle Specs

<b>Frame:</b>	<b>Aluminum</b>
<b>Wheel Size:</b>	<b>26 in</b>
<b>Fork:</b>	<b>Suspension Forks</b>
<b>Rear Shocks:</b>	<b>N/A</b>
<b>Bottom Bracket:</b>	<b>Cartridge Sealed</b>
<b>Tires:</b>	<b>Mountain, 26 x 2.35 inches</b>
<b>Front Brake:</b>	<b>Mechanical Disc Brake</b>
<b>Rear Brake:</b>	<b>Disc Brakes</b>
<b>Spokes:</b>	<b>12G</b>
<b>Headset:</b>	<b>1 1/8"</b>
<b>Weight</b>	<b>32 kg total weight</b>
<b>Speed (Number of Gears)</b>	<b>7-Speed Gears</b>

PHATMOTO



**Phatmoto.com**  
**sales@phatmoto.com**  
**(877) 354-3733**