

# Instructions



# Pulse™ Pump Air Control (PAC)

3A5410L  
EN

Controls an air powered pump via a 3-way air solenoid valve and RF radio communication with the Pulse Hub. The air solenoid valve provides electronic pump control by turning the pump air supply on and off. Use with a Pulse HUB only. For indoor use only. Not approved for use in European explosive atmosphere locations.

## Part Nos.:

Model	Description	Approval
24Z676	NPT with flying leads	
24Z677	BSPP with flying leads	
24Z728	NPT with NEMA-15 plug	 3156614 Conforms to UL Standard 61010-1 and 61010-2-201 Certified to CAN/CSA Standard C22.2 No. 61010-1 and 61010-2-201

## Related Manuals

3A5414 - Pulse HUB



Maximum Air Pressure: 145 PSI (1 MPa, 10 bar)



## Important Safety Instructions

Read all warnings and instructions in this manual and all related Pulse manuals. Save all instructions.

Contains Model XBee S2C Radio, IC: 1846A-XBS2C (Models 24Z676 and 24Z677), IC:1846A-PS2CM (Model 24Z728).

The PAC contains FCC ID MCQ-XBS2C (Models 24Z676 and 24Z677), FCC ID MCQ-PS2CSM (Model 24Z728). This device complies with Part 15 of the FCC Rules. Operation is subject to the following two conditions:

- This device may not cause harmful interference.
- This device must accept any interference received, including interference that may cause undesired operation.

## Contents

<b>Warnings</b> .....	<b>3</b>
<b>Installation</b> .....	<b>5</b>
Wiring .....	5
Grounding .....	5
Pressure Relief Procedure .....	5
Remote Mounting (Optional) .....	6
Choosing Installation Location .....	6
<b>Registering the PAC</b> .....	<b>10</b>
Mode Configuration .....	10
<b>Manual Override</b> .....	<b>11</b>
<b>Operation</b> .....	<b>12</b>
Status Codes .....	12
Pulse Mode, No Errors .....	12
Pulse Mode, Pump On .....	12
Pulse Mode, Not Registered .....	13
Work Off Line Mode, No Errors .....	13
<b>Troubleshooting</b> .....	<b>14</b>
Error Codes .....	14
Pulse Mode, Open Circuit Error .....	14
Work Off Line Mode, Open Circuit Error .....	14
Pulse Mode, Short Circuit Error .....	15
Work Off Line Mode, Short Circuit Error .....	15
Troubleshooting Table .....	16
<b>Service</b> .....	<b>17</b>
Air Solenoid Valve Replacement .....	17
Disassembly .....	17
Reassembly .....	18
Cable Assembly (24Z670) Replacement .....	20
Disassembly .....	20
Reassembly .....	21
<b>Parts</b> .....	<b>23</b>
<b>Technical Specifications</b> .....	<b>26</b>
<b>Mounting Hole Layout</b> .....	<b>27</b>
<b>Graco Extended Pump Air Control Warranty</b> .....	<b>28</b>

# Warnings

The following warnings are for the setup, use, grounding, maintenance, and repair of this equipment. The exclamation point symbol alerts you to a general warning and the hazard symbols refer to procedure-specific risks. When these symbols appear in the body of this manual or on warning labels, refer back to these Warnings. Product-specific hazard symbols and warnings not covered in this section may appear throughout the body of this manual where applicable.

## **WARNING**



### **ELECTRIC SHOCK HAZARD**

This equipment must be grounded. Improper grounding, setup, or usage of the system can cause electric shock.



- Turn off and disconnect at main switch or power cord before servicing equipment.
- Connect only to grounded electrical power source or grounded outlets.
- All electrical wiring must be done by a qualified electrician and comply with all local codes and regulations.



### **FIRE AND EXPLOSION HAZARD**

When flammable fluids are present in the work area, such as gasoline and windshield wiper fluid, be aware that flammable fumes can ignite or explode. To help prevent fire and explosion:



- Use equipment only in well-ventilated area.
- Eliminate all ignition sources, such as cigarettes and portable electric lamps.
- Ground all equipment in the work area.
- Keep work area free of debris, including rags and spilled or open containers of solvent and gasoline.
- Do not plug or unplug power cords or turn lights on or off when flammable fumes are present.
- Use only grounded hoses.
- **Stop operation immediately** if static sparking occurs or you feel a shock. Do not use equipment until you identify and correct the problem.
- Keep a working fire extinguisher in the work area.

## **WARNING**



### **EQUIPMENT MISUSE HAZARD**

Misuse can cause death or serious injury.

- Do not operate the unit when fatigued or under the influence of drugs or alcohol.
- Do not exceed the maximum working pressure or temperature rating of the lowest rated system component. See **Technical Specifications** in all equipment manuals.
- Use fluids and solvents that are compatible with equipment wetted parts. See **Technical Specifications** in all equipment manuals. Read fluid and solvent manufacturer's warnings. For complete information about your material, request Safety Data Sheets (SDSs) from distributor or retailer.
- Turn off all equipment and follow the **Pressure Relief Procedure** when equipment is not in use.
- Check equipment daily. Repair or replace worn or damaged parts immediately with genuine manufacturer's replacement parts only.
- Do not alter or modify equipment. Alterations or modifications may void agency approvals and create safety hazards.
- Make sure all equipment is rated and approved for the environment in which you are using it.
- Use equipment only for its intended purpose. Call your distributor for information.
- Route hoses and cables away from traffic areas, sharp edges, moving parts, and hot surfaces.
- Do not kink or over bend hoses or use hoses to pull equipment.
- Keep children and animals away from work area.
- Comply with all applicable safety regulations.



### **PERSONAL PROTECTIVE EQUIPMENT**

Wear appropriate protective equipment when in the work area to help prevent serious injury, including eye injury, hearing loss, inhalation of toxic fumes, and burns. Protective equipment includes but is not limited to:

- Protective eye wear, and hearing protection.
- Respirators, protective clothing, and gloves as recommended by the fluid and solvent manufacturer.

### **CALIFORNIA PROPOSITION 65**

This product contains a chemical known to the State of California to cause cancer, birth defects or other reproductive harm. Wash hands after handling.

## Installation

**NOTE:** The PAC can be directly mounted to the air inlet of an air powered pump. Additional (user supplied) fittings are required for this installation.



Numbers 1-3 in the solenoid (14) housing identify the connection ports (FIG. 1).

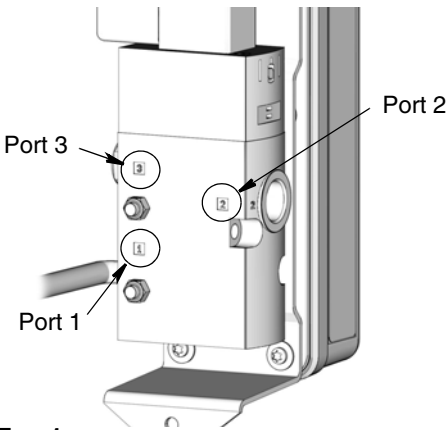

**FIG. 1**

- Port 1: Air supply connection.
  - Port 2: Air inlet of pump connection.
  - Port 3: Muffler (already installed).
1. Apply thread sealant to male threads of fittings. Connect air supply line to Port 1 (FIG. 1).
  2. Apply thread sealant to male threads of fittings. Connect line to the pump air inlet to Port 2 (FIG. 1).
  3. Tighten fittings securely.
  4. **For model 24Z728:** Plug power cord into a grounded outlet. If available, A covered outlet box should be used to prevent accidental disconnect.

**For models 24Z676 and 24Z677 (with**

3A5410L

**floating leads):** make electric connections. Comply with all local codes and regulations. See Wiring instructions.

## Wiring

### Grounding



The equipment must be grounded. Grounding reduces the risk of static and electric shock by providing an escape wire for the electrical current due to static build up or in the event of a short circuit.

Connect power cord to a 3-wire grounded plug or junction box according to your local electrical code.

The green ground wire must be attached to the green grounding screw. Connect white wire to neutral and black wire to line.

### Pressure Relief Procedure

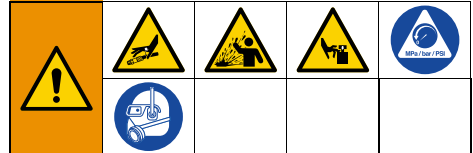

This equipment stays pressurized until pressure is manually relieved. To help prevent serious injury from pressurized fluid, such as skin injection, splashing fluid and moving parts, follow the Pressure Relief Procedure when you stop dispensing and before cleaning, checking, or servicing the equipment.

1. Turn off the master bleed air valve located upstream of the PAC.
2. Follow the **Pressure Relief Procedure** for downstream components such as pumps and dispense valves. See the component instruction manuals for these procedures.

# Installation

## Remote Mounting (Optional)

The PAC electronics enclosure can be mounted in a remote, secure location away from the air solenoid valve. The wall mounting bracket (11) for installing the PAC electronics enclosure is included.

The user must provide an 18 gauge, SJOOW cable to connect the PAC electronics enclosure to the air solenoid valve. The maximum wire length is 75 feet (22.86 m).

**NOTE:** The cord grip is designed for cord diameters of 0.230 inches to 0.345 inches (5.8 mm to 8.7 mm) which is compatible with most 18 gauge, SJOOW cable. In the event the 18 gauge, SJOOW cable has a diameter outside of this range, it may be necessary to replace the cord grip with one that is compatible with the cord diameter being used.

## Choosing Installation Location

Select a location that will adequately support the weight of the PAC as well as all plumbing and electrical connections.

Refer to the **Mounting Hole Layout** provided on page 27. Use designated holes and provided configurations only. No other mounting configuration should be used.

Use two, #10 screws (5 mm) (or equivalent) fasteners to secure the PAC to the mounting surface.



1. Verify power to the PAC is disconnected.
2. Perform **Pressure Relief Procedure**, page 5.
3. Remove three screws (12), washers (25) and o-rings (9) securing PAC bracket (11) to enclosure (2) (FIG. 2).

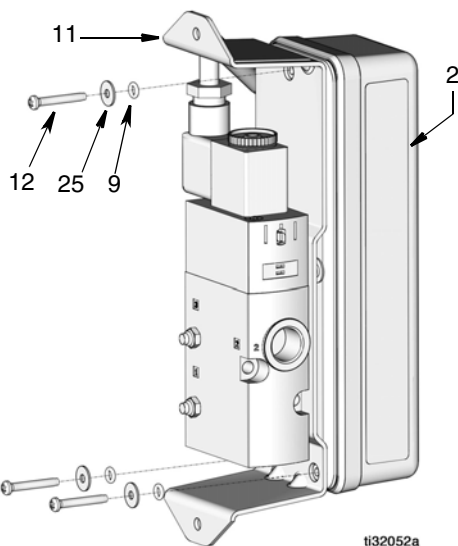

FIG. 2 t132052a

4. Remove two screws (8) and nuts (16) holding solenoid valve (14) to bracket (11) and remove solenoid valve from bracket (FIG. 3).

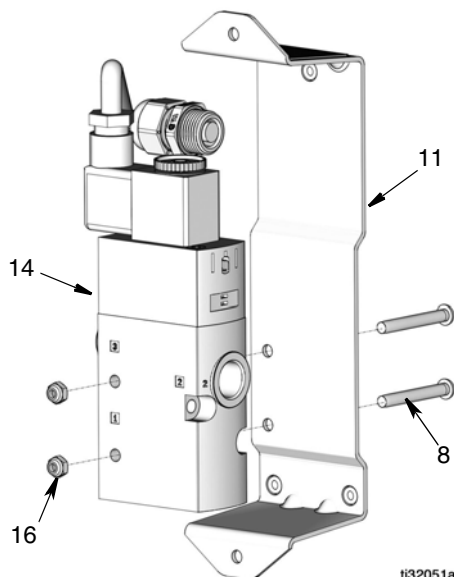
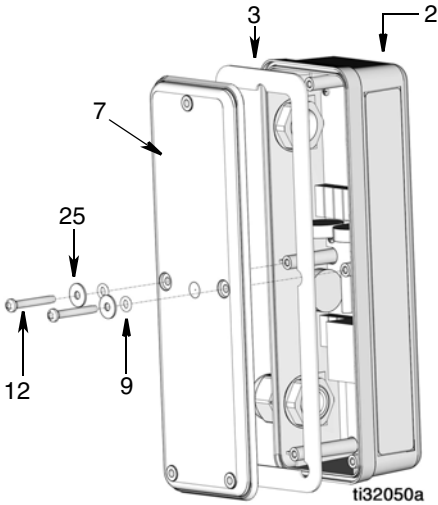

FIG. 3 t132051a

- Remove two screws (12), washers (25) and o-ring (9) from the PAC cover (7) and remove the cover and seal (3) from the PAC electronics enclosure (2) (FIG. 4).



**FIG. 4**

- Inside PAC electronics enclosure (2), disconnect neutral (white) and line (black) wires from SOL - (white) and SOL + (black) from the terminal block (FIG. 5).
- Loosen cord grip (19) and completely remove cable (FIG. 5).

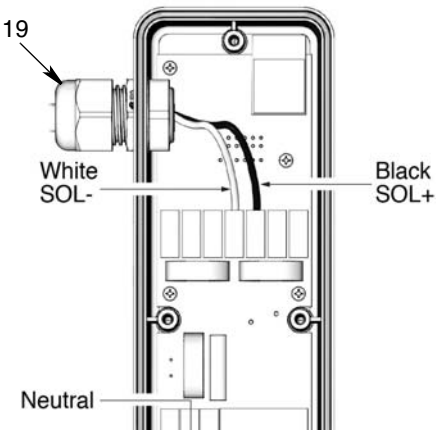

**FIG. 5**

- Loosen screw (13a) on the back of the mini DIN solenoid connector (14a) and disconnect it from the solenoid connector (14a) (FIG. 6).

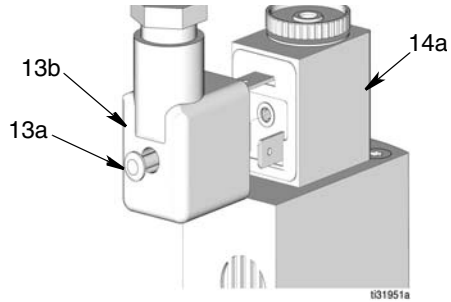
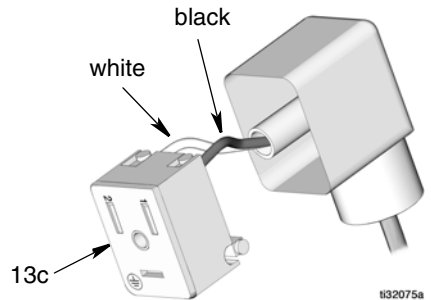

**FIG. 6**

- Remove the retainer plate (13c) from the DIN connector (FIG. 7).

Inside the DIN connector, disconnect the black wire from the terminal labeled 1, the white wire from the terminal labeled 2 (FIG. 7). If the connector is not damaged, it can be reused for assembly with the longer cord in Step 12, Page 8.

**NOTE:** A replacement DIN connector (Part No. 24Z670) is available from Graco.



**FIG. 7**

# Installation

10. Replace the solenoid connector cable (13) with a longer (user supplied) 18 gauge, SJOOW cable (75 feet [22.8 m] maximum).

Feed one end of the cable through the cord grip (19) and into the PAC enclosure (2)

11. Inside the PAC enclosure (2), connect the neutral (white) wire to SOL - (white) and the line (black) wire to SOL + (black) in the terminal block (FIG. 8).

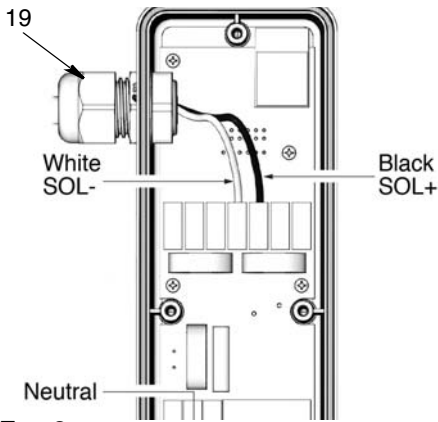

**FIG. 8**

12. Insert the other end of the connector cable into the mini DIN solenoid connector. Connect the line (black) wire to the terminal labeled 1, the neutral (white) wire to the terminal labeled 2 (FIG. 9).
13. Replace the retainer plate (13c) in the DIN connector (13b) (FIG. 9).

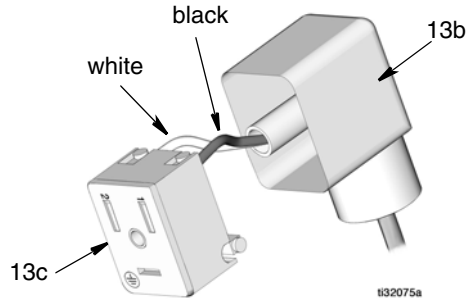

**FIG. 9**

14. Reconnect the DIN connector (13b) to solenoid connector (14a) (FIG. 10).
15. Tighten screw (13a) on back of mini DIN solenoid connector (13b) (FIG. 10).

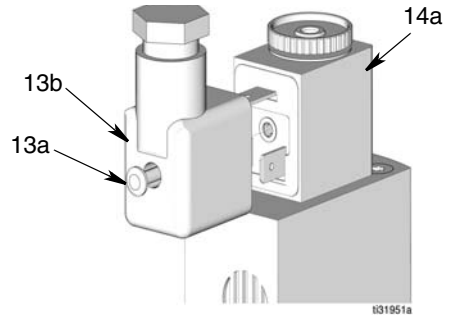
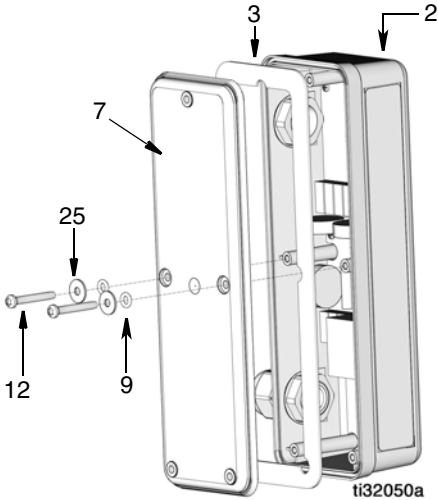

**FIG. 10**

16. Tighten cord grip (19).
17. Remotely mount air solenoid valve securely to the air inlet of the pump (see **Installation**, page 5).



18. Install seal (3) in PAC cover (7) (FIG. 11).
19. Install cover over PAC enclosure (2). Verify all screw holes in cover and enclosure are correctly aligned (FIG. 11).
20. Install two o-rings (9), washers (25) and screws (12) to secure the cover to the PAC enclosure (2) (FIG. 11).



**FIG. 11**

21. Align PAC enclosure assembly (2) to the bracket (11). Install o-rings (9), washers (25) and screws (12) to secure bracket to enclosure (FIG. 12).

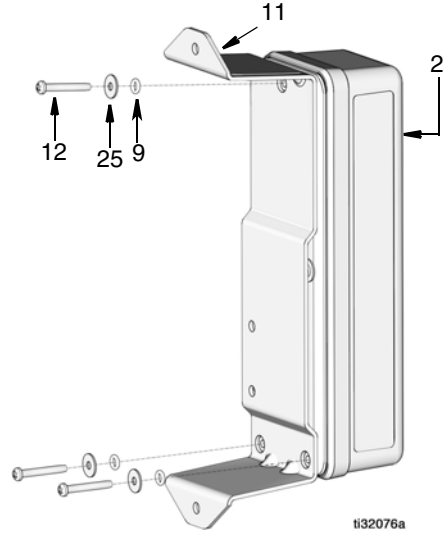

**FIG. 12**

22. Route solenoid connector cable to the desired PAC enclosure assembly location.
23. Mount bracket and PAC to a secure location.
24. Connect power. See **Wiring**, page 5.

# Registering the PAC

## Registering the PAC

1. Perform **Pressure Relief Procedure**, page 5.
2. On the Pulse Fluid Management Software turn on the DISCOVERY mode.
3. Connect power to the PAC. (Red light (d) turns on.) Wait 30 seconds. (Blue light (b) turns on.) (FIG. 13)
4. On the PAC, press and hold the Mode button (a) for 5 seconds (FIG. 13). (Green light (c) turns on. Blue light (b) and Red light (d) turn off.)
5. Press and hold the Mode button (a) again for 5 seconds, then release (FIG. 13). (Green light (c) stays on. Blue light (b) and Red light (d) turn on.)
6. Wait 5 to 10 seconds. (Green light (c) turns off. Blue light (b) starts flashing. Red light (d) stays on.)
7. When the Blue light (b) stops flashing and turns solid blue, the PAC registration sequence is complete (1 to 3 minutes) (FIG. 13). (Red light (d) stays on.)
8. Configure the PAC within the Pulse Fluid Management Software
9. Wait 1 to 3 minutes for the Red light (d) to turn off. PAC is now configured.

- In the Pulse (preferred) (FIG. 16) mode, the pump will not operate unless it receives authorization from the Pulse software.

**NOTE:** In this mode, the Pulse (b) continuous blue light is on.

- The Work Off Line mode (FIG. 19) turns on air to the pump so the pump can be energized without an authorization through Pulse.

**NOTE:** In this mode, the Work Off Line (c) continuous green light is on.

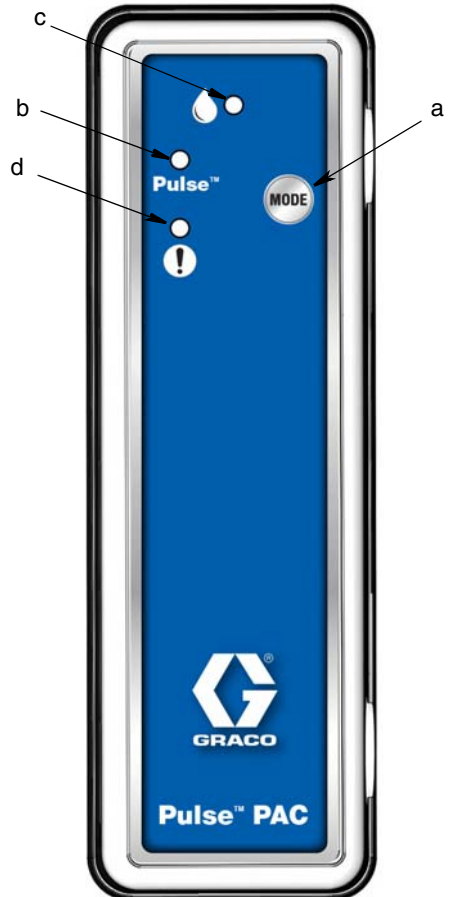

FIG. 13

## Mode Configuration

Press and hold MODE button (a) for 5 seconds (FIG. 13) to select Pulse or Work Off Line mode.

**NOTE:** See **Pulse Mode, No Errors** (FIG. 16, page 12) and **Work Off Line Mode, No Errors**, FIG. 19, page 13).

## Manual Override

**NOTE:** Manual Override mode supersedes the electronic Work Off Line mode.

This mode of operation should only be used for system setup.

The blue manual override switch (e) turns on air to the pump and primes the system without electrical power.

To set the blue manual override switch:

1. Insert a small, flat screwdriver in the slot of the blue manual override switch screw (e) (FIG. 15).
2. Rotate the blue manual override switch screw (e) clockwise 1/4 turn.

### NOTICE

Do not turn the blue manual override switch screw (e) more than a 1/4 turn. Overturning this screw could cause it to break, rendering the unit inoperable.

3. Before resuming normal PAC operation with Pulse, reset the blue manual override switch screw (e) to the normal operation position. Insert a small, flat screwdriver in the slotted opening and turn the blue manual override switch screw counter-clockwise back to the original position (FIG. 15).

The blue manual override switch screw (e) in FIG. 14 is set to the override position.

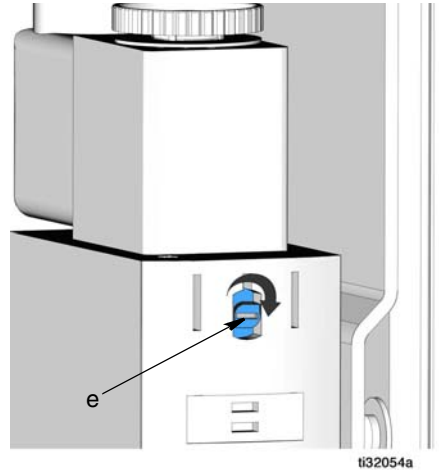

**FIG. 14**

The blue manual override switch screw (e) in FIG. 15 is set to the normal operation position.

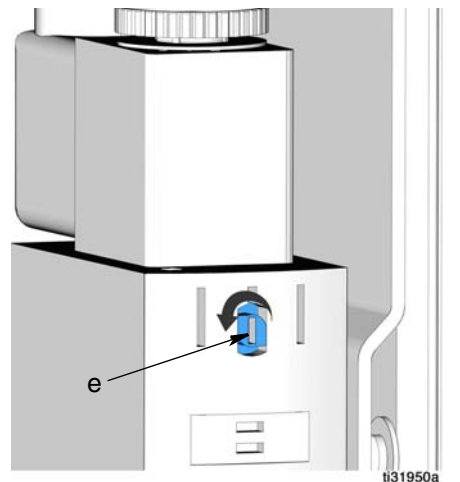

**FIG. 15**

## Operation

### Status Codes

LEDs on the PAC illuminate and/or flash to report the status or error code of the PAC. Refer to FIG. 16 - FIG. 23 to determine the PAC status.

### Pulse Mode, No Errors

In Pulse Mode:

- The pump is controlled by Pulse software.
- The pump is only energized when needed or authorized by the Pulse software.

### Pulse Mode, Pump On

The pump is actuated by the Pulse software for an authorized dispense.

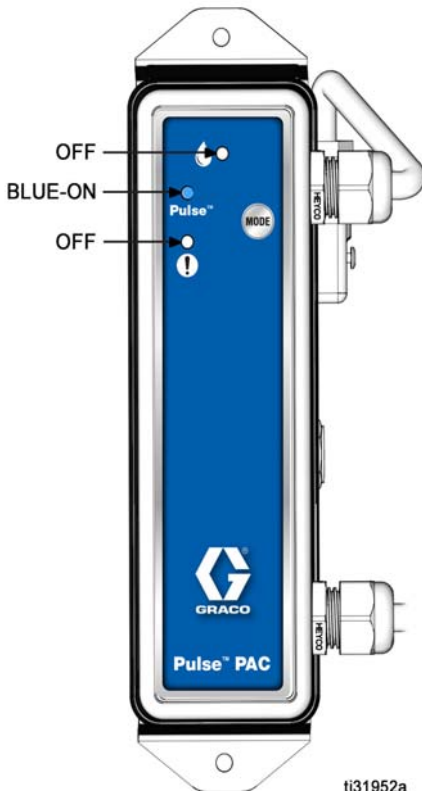

FIG. 16

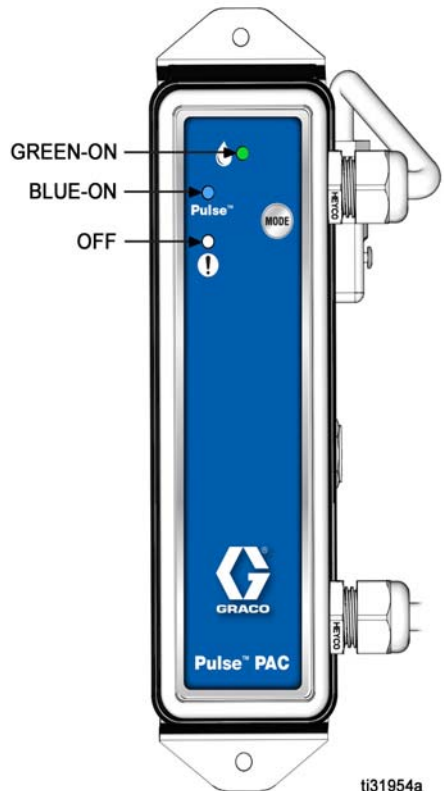

FIG. 17

## Pulse Mode, Not Registered

**NOTE:** Instructions for **Registering the PAC** are provided on page 10.

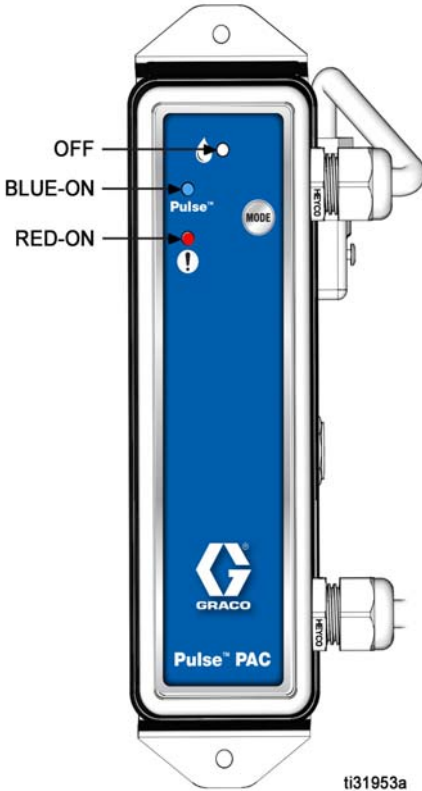

FIG. 18

## Work Off Line Mode, No Errors

In Work Off Line Mode:

- The pump is always energized if the PAC has electrical power.
- Used only when experiencing RF communication failure.

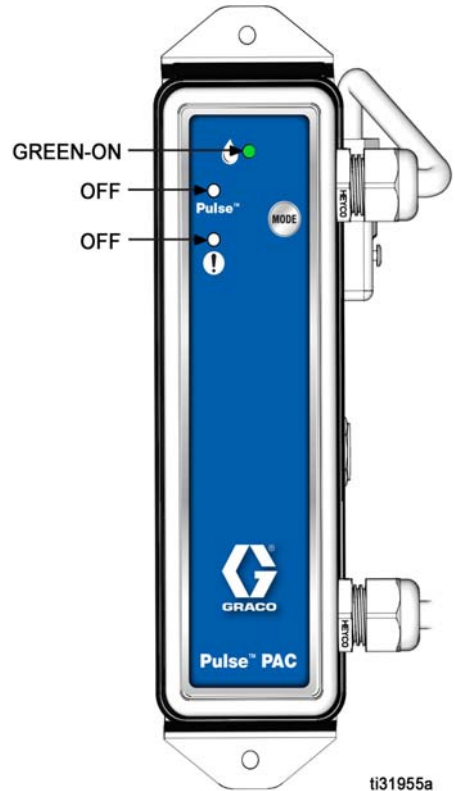

FIG. 19

## Troubleshooting

### Error Codes

#### Pulse Mode, Open Circuit Error

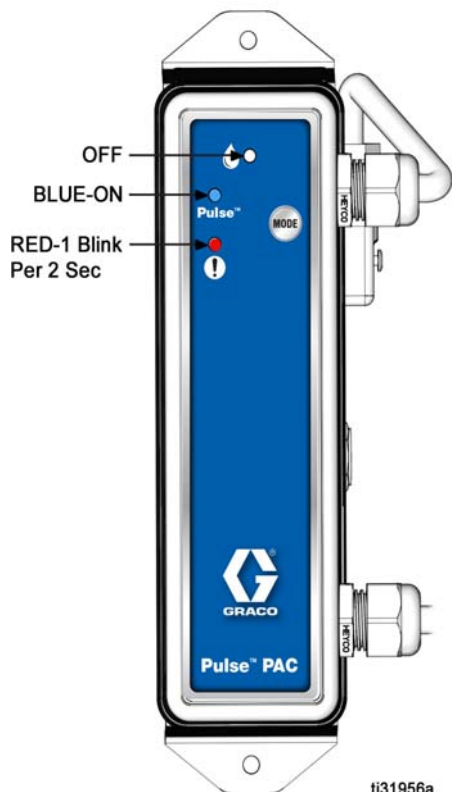

FIG. 20

#### Work Off Line Mode, Open Circuit Error

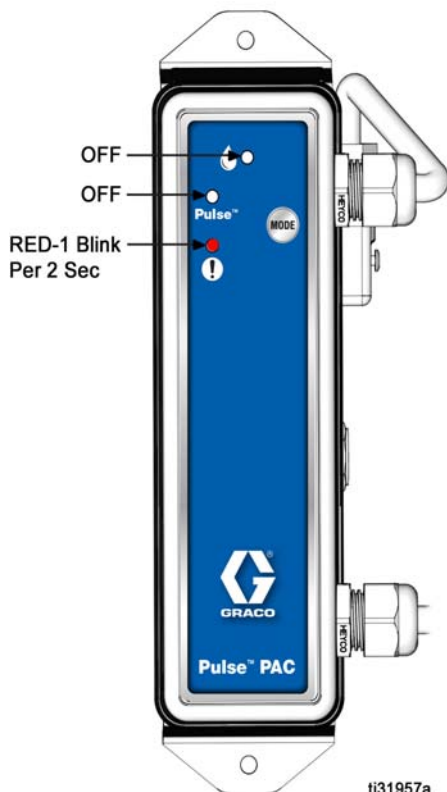

FIG. 21

## Pulse Mode, Short Circuit Error

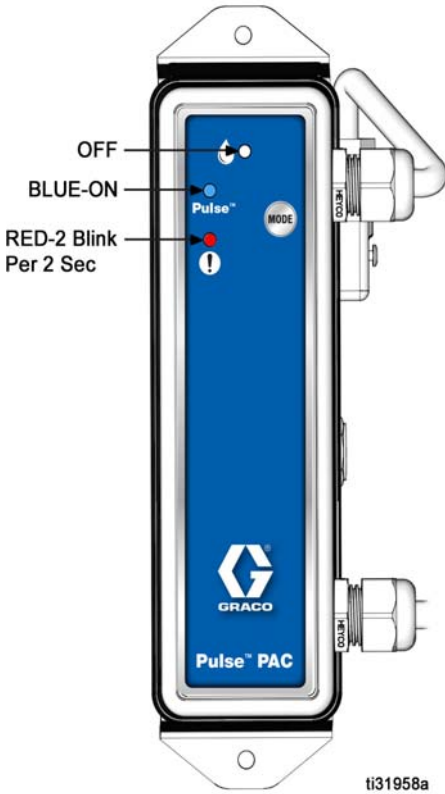

FIG. 22

## Work Off Line Mode, Short Circuit Error

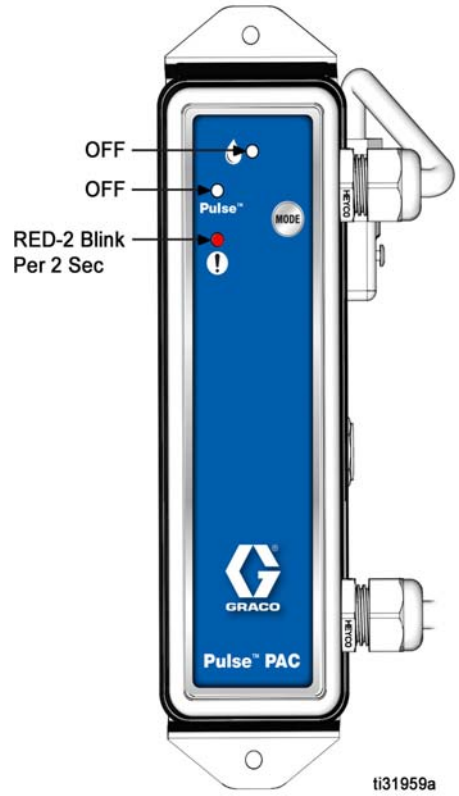

FIG. 23

# Troubleshooting

## Troubleshooting Table

<b>Problem</b>	<b>Cause</b>	<b>Solution</b>
Open circuit error (red light, single flash)	Air solenoid valve electric circuit has been compromised	Check wiring. If damaged or worn, replace cable assembly. Order Graco part number 24Z670. Replace air solenoid valve
Closed circuit error (red light, double flash)	Air solenoid valve electric circuit has been compromised	Check wiring. If damaged or worn, replace cable assembly. Order Graco part number 24Z670. Replace air solenoid valve
Air pump will not shut off in Pulse mode	Air solenoid valve has been placed in manual override	Turn manual override 1/4 turn, counter-clockwise.
Weak or no RF signal	Changes/obstructions in RF pathway (i.e., vehicle, overhead doors)	Add Graco Extender to Pulse System. Order Graco Part No. 17F885 - US/Canada; 17F886 - EU; 17F887 - UK; 17F888 - ANZ.
Device is unable to register to the Pulse Pro network or device does not rejoin the network after system reboot.	Device is not meshing properly with the device network.	Toggle to Discovery mode on the HUB. Wait one minute and toggle it back. If this does not resolve the issue, cycle the power on the PAC. It may take up to ten minutes for the PAC to rejoin a network.



## Service

### Air Solenoid Valve Replacement

#### Disassembly



1. Verify power to the PAC is disconnected.
2. Perform **Pressure Relief Procedure**, page 5.
3. Disconnect the air supply line from the port numbered 1 on the solenoid valve (14) and the pump air line from the port numbered 2 (FIG. 24).

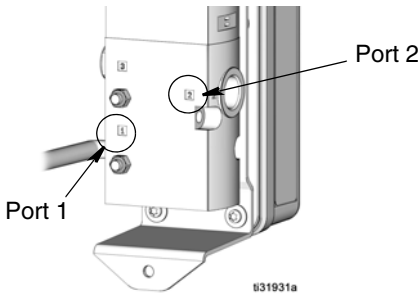

**FIG. 24**

4. Loosen screw (13a) on the back of the mini DIN solenoid connector (14a) and disconnect it from the solenoid connector (14a) (FIG. 25).

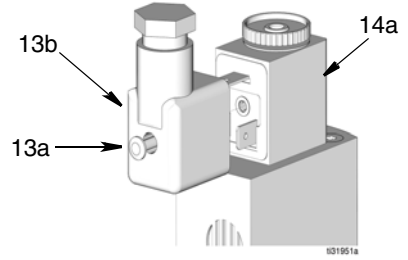

**FIG. 25**

5. Remove three screws (12), washers (25) and o-rings (9) securing PAC bracket (11) to enclosure (2) (FIG. 26).

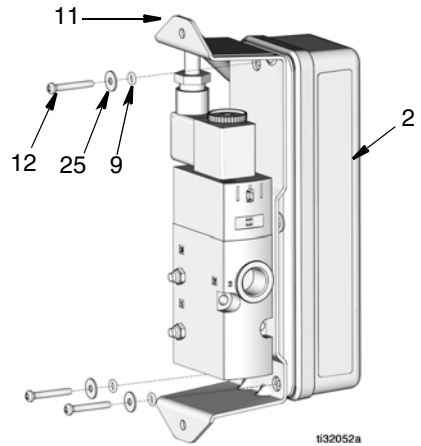

**FIG. 26**

6. Remove two screws (8) and nuts (16) holding solenoid valve (14) to bracket (11) and remove solenoid valve from bracket (FIG. 27).

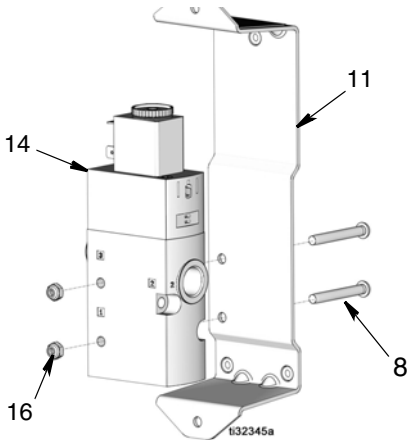

**FIG. 27**

7. Remove muffler (17) from the port numbered 3 in the solenoid valve (14) (FIG. 28).

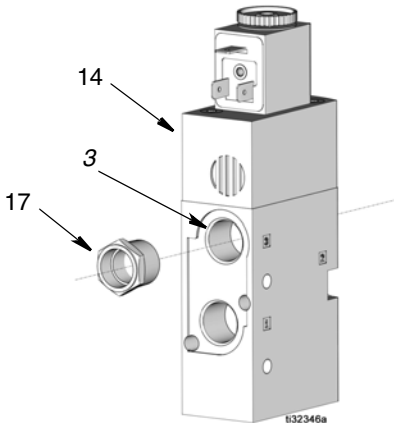

**FIG. 28**

## Reassembly

1. Install muffler (17) in the port numbered 3 on the new solenoid valve (14) (FIG. 28).
2. Align solenoid valve (14) with bracket (11). Install two screws (8) and nuts (16) as shown in FIG. 29 to secure solenoid valve (14) to bracket (11). Tighten nuts securely.

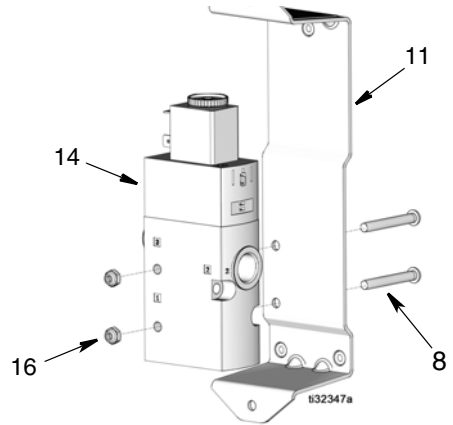

**FIG. 29**

3. Align PAC enclosure assembly (2) to the bracket (11). Install o-rings (9), washers (25) and screws (12) to secure bracket to enclosure (FIG. 30).

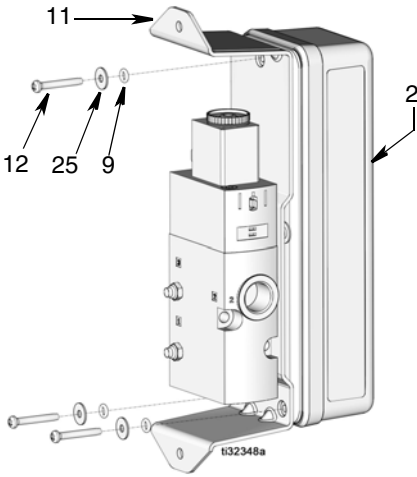

**FIG. 30**

4. Reconnect the DIN connector (13b) to solenoid connector (14a) (FIG. 31).
5. Tighten screw (13a) on back of mini DIN solenoid connector (13b) (FIG. 31).

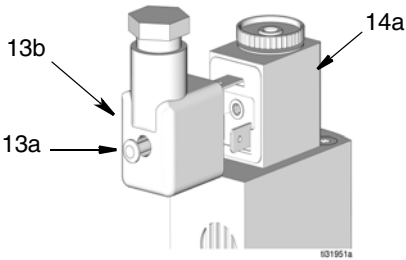

**FIG. 31**

6. Apply thread sealant to male threads of fittings. Connect air supply line to port 1 (FIG. 32).
7. Apply thread sealant to male threads of fitting. Connect line to the pump air inlet to port 2 (FIG. 32).

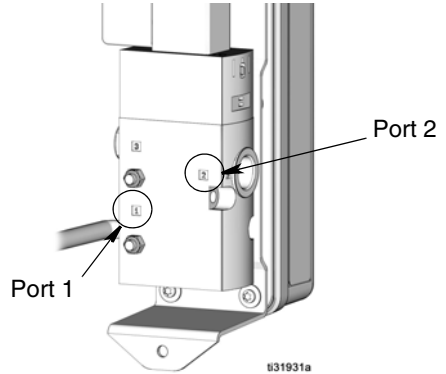

**FIG. 32**

8. Tighten fittings securely.
9. Connect power. See Wiring, page 5.

## Cable Assembly (24Z670) Replacement

### Disassembly



1. Verify power to the PAC is disconnected.
2. Perform **Pressure Relief Procedure**, page 5.
3. Remove three screws (12), washers (25) and o-rings (9) securing PAC bracket (11) to enclosure (2) (FIG. 33).

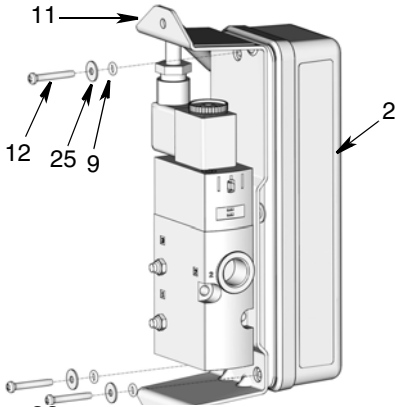

FIG. 33

4. Remove two screws (12), washers (25) and o-ring (9) from the PAC cover (7) and remove the cover and seal (3) from the PAC electronics enclosure (2) (FIG. 34).

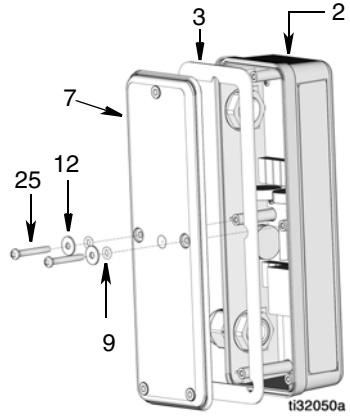

FIG. 34

5. Inside PAC electronics enclosure (2), disconnect neutral (white) and line (black) wires from SOL - (white) and SOL + (black) from the terminal block (FIG. 35).

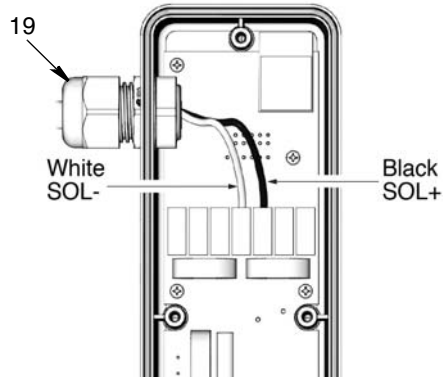
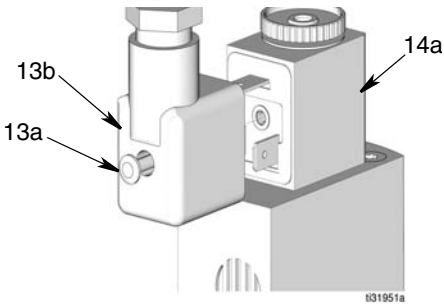

FIG. 35

6. Loosen cord grip (19) and completely remove cable (FIG. 35).

- Loosen screw (13a) on the back of the mini DIN solenoid connector (14a) and disconnect it from the solenoid connector (14a). Discard cord assembly (FIG. 36).



**FIG. 36**

## Reassembly

- Feed one end of the cable through the cord grip (19) and into the PAC enclosure (2).
- Inside the PAC electronics enclosure (2), connect the neutral (white) wire to SOL - (white) and the line (black) wire to SOL + (black) in the terminal block (FIG. 37).

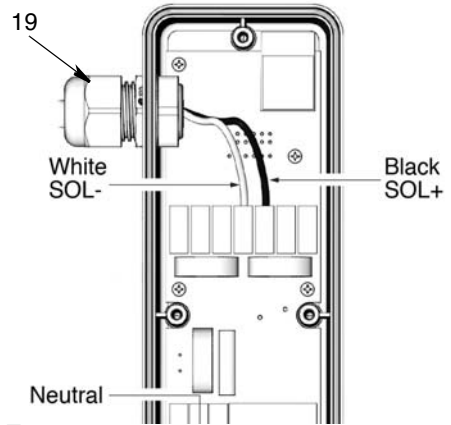
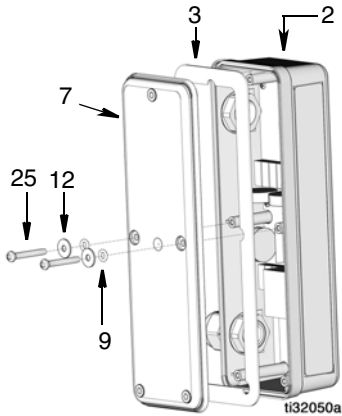

**FIG. 37**

- Reconnect the DIN connector (13b) to solenoid connector (14a) (FIG. 36).
- Tighten cord grip (19) (FIG. 37).
- Install seal (3) inside PAC cover (7) (FIG. 34).
- Install cover over PAC enclosure (2). Verify all screw holes in cover and enclosure are correctly aligned (FIG. 34).

# Service

7. Install two o-rings (9), washers (25) and screws (12) to secure the cover to the PAC electronics enclosure (2) (FIG. 38).



**FIG. 38**

8. Align PAC electronics enclosure assembly (2) to the bracket (11). Install o-rings (9), washers (25) and screws (12) to secure bracket to enclosure (FIG. 39).

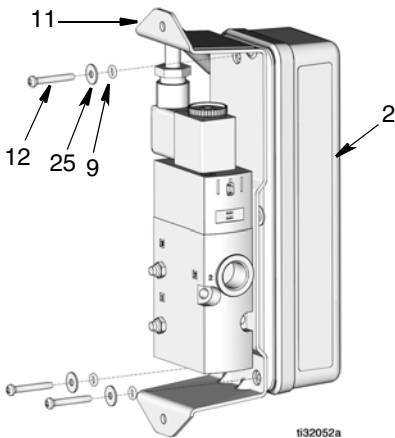

**FIG. 39**

9. Tighten screw (13a) on back of mini DIN solenoid connector (13b) (FIG. 40).

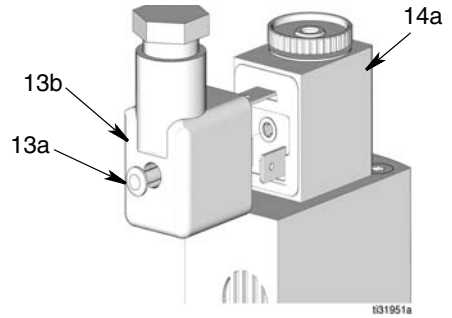

**FIG. 40**

10. Install PAC in installation location.
11. Connect power. See Wiring, page 5.

## Parts

Ref	Part No.	Description	Qty
1		LABEL, PAC	1
2		COVER, enclosure	1
3		SEAL	1
5		BOARD, assembly	1
6		SCREW, pnh #2,thd forming	6
7		BASE, enclosure	1
8		SCREW, M5 x 0.8 x 40, torx head	2
9		PACKING, o-ring	5
10		LABEL, identification	1
11	17N859	BRACKET, mounting	1
12		SCREW, plastic tapping 3.5-25	5
13	24Z670	CABLE, assembly	1
14	17N861	VALVE, solenoid, 3/8 NPT (models 24Z676, 24Z728)	1
	17N933	VALVE, solenoid, 3/8 BSPP (model 24Z677)	1

Ref	Part No.	Description	Qty
16	17S037	NUT, lock	2
17		MUFFLER, 3/8-18 NPT	1
18	17P579	CORD, pigtail, molded (model 24Z728)	1
		CABLE, 6 ft., 3-wire, 18AWG (models 24Z676, 24Z677)	1
19	121036	GRIP, cord	2
20▲	189930	LABEL, electric shock	1
25		WASHER, ID 3.5, OD 11, ST	5

▲ Replacement Danger and Warning labels, tags, and cards are available at no cost.

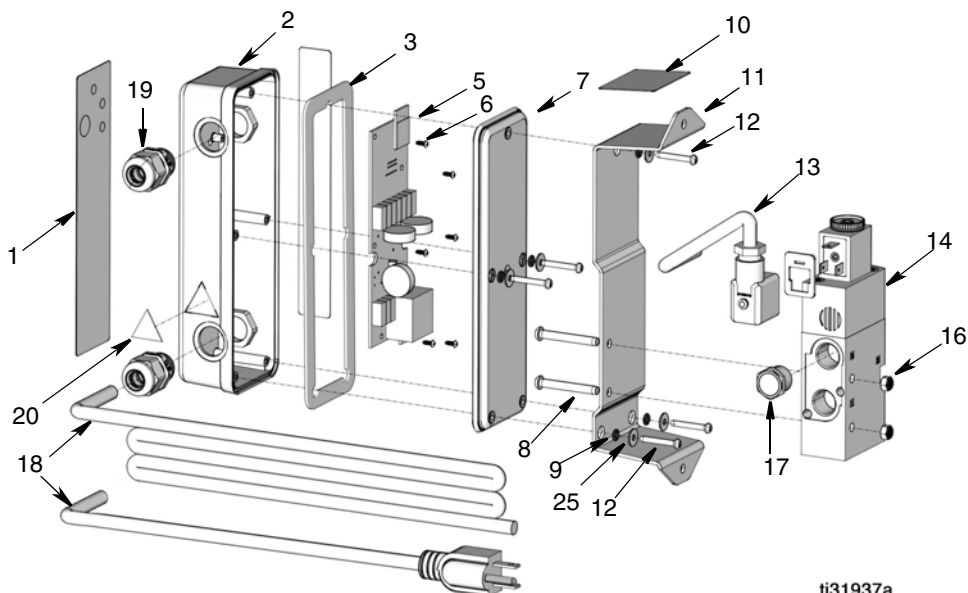

ti31937a







# Technical Specifications

## Technical Specifications

PAC		
Minimum Operating Pressure	36 PSI	0.25 MPa, 2.5 bar
Maximum Operating Pressure	145 PSI	1.0 MPa, 10 bar
Maximum Air Flow	93 SCFM (2.6m <sup>3</sup> /min.)	
Power Supply	100-240 VAC (+/- 10%) line voltage, 24VDC solenoid	
Power Cord		
Model 24Z676, 24Z677	6 ft. SJOOW, 3-wire, 18 gauge cable with flying leads	
Model 24Z728	Power cord with integrated NEMA 5-15 plug	
Current	25-60 mA	
RF Frequency Band	2400-2483.5 MHz	
Maximum RF Transmit Power		
Model 24Z676, 24Z677	6.3 mW (8 dBm)	
Model 24Z728	63 mW (18 dBm)	
Connection Ports Size (inlet, outlet, exhaust)		
Model 24Z676, 24Z728	3/8 in. NPT	
Model 24Z677	3/8 BSPP	
Operating Temperature Range	14°F to 122°F	-10°C to 50°C
Storage Temperature Range	-40°F to 185°F	-40°C to 85°C
Maximum Operating Altitude	6560 ft above sea level	2000 m above sea level
Operating Humidity Range	0-80% (non-condensing)	
Pollution Degree	Intended Environmental: Pollution Degree 2	
Weight	2.44 lbs	1.11 kg
Ingress Protection	IP65	

# Mounting Hole Layout

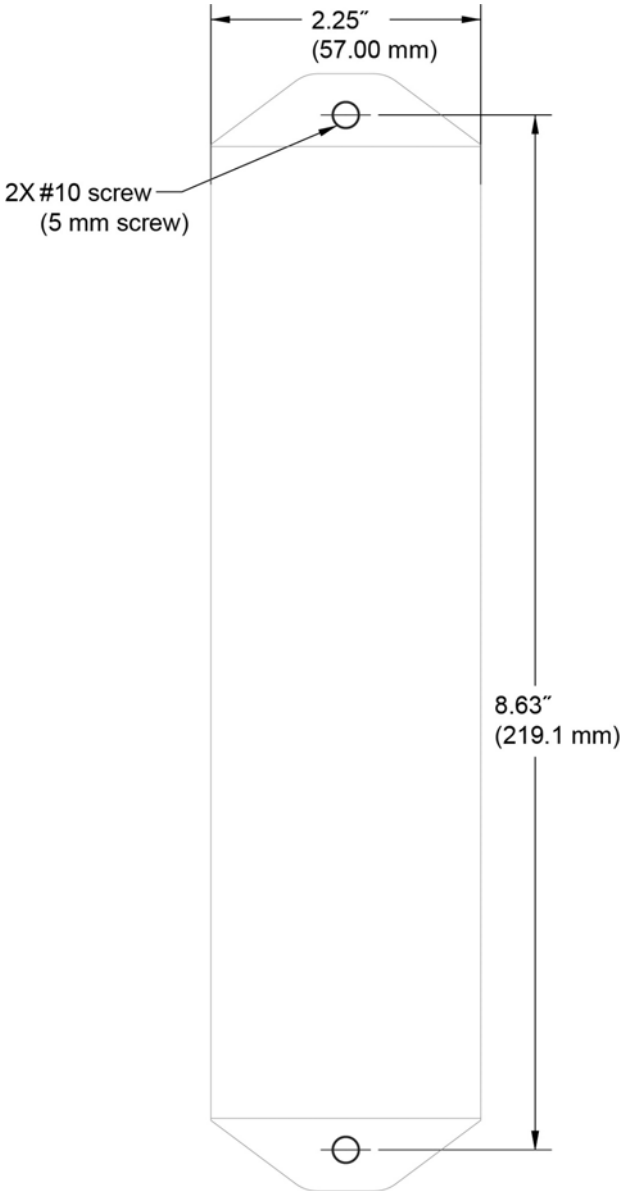

# Graco Extended Pump Air Control Warranty

Graco warrants all equipment referenced in this document which is manufactured by Graco and bearing its name to be free from defects in material and workmanship on the date of sale to the original purchaser for use. With the exception of any special, extended, or limited warranty published by Graco, Graco will, for a period of twenty four months from the date of sale, repair or replace any part of the equipment determined by Graco to be defective. This warranty applies only when the equipment is installed, operated and maintained in accordance with Graco's written recommendations.

This warranty does not cover, and Graco shall not be liable for general wear and tear, or any malfunction, damage or wear caused by faulty installation, misapplication, abrasion, corrosion, inadequate or improper maintenance, negligence, accident, tampering, or substitution of non-Graco component parts. Nor shall Graco be liable for malfunction, damage or wear caused by the incompatibility of Graco equipment with structures, accessories, equipment or materials not supplied by Graco, or the improper design, manufacture, installation, operation or maintenance of structures, accessories, equipment or materials not supplied by Graco.

This warranty is conditioned upon the prepaid return of the equipment claimed to be defective to an authorized Graco distributor for verification of the claimed defect. If the claimed defect is verified, Graco will repair or replace free of charge any defective parts. The equipment will be returned to the original purchaser transportation prepaid. If inspection of the equipment does not disclose any defect in material or workmanship, repairs will be made at a reasonable charge, which charges may include the costs of parts, labor, and transportation.

**THIS WARRANTY IS EXCLUSIVE, AND IS IN LIEU OF ANY OTHER WARRANTIES, EXPRESS OR IMPLIED, INCLUDING BUT NOT LIMITED TO WARRANTY OF MERCHANTABILITY OR WARRANTY OF FITNESS FOR A PARTICULAR PURPOSE.**

Graco's sole obligation and buyer's sole remedy for any breach of warranty shall be as set forth above. The buyer agrees that no other remedy (including, but not limited to, incidental or consequential damages for lost profits, lost sales, injury to person or property, or any other incidental or consequential loss) shall be available. Any action for breach of warranty must be brought within two (2) years of the date of sale.

**GRACO MAKES NO WARRANTY, AND DISCLAIMS ALL IMPLIED WARRANTIES OF MERCHANTABILITY AND FITNESS FOR A PARTICULAR PURPOSE, IN CONNECTION WITH ACCESSORIES, EQUIPMENT, MATERIALS OR COMPONENTS SOLD BUT NOT MANUFACTURED BY GRACO.** These items sold, but not manufactured by Graco (such as electric motors, switches, hose, etc.), are subject to the warranty, if any, of their manufacturer. Graco will provide purchaser with reasonable assistance in making any claim for breach of these warranties.

In no event will Graco be liable for indirect, incidental, special or consequential damages resulting from Graco supplying equipment hereunder, or the furnishing, performance, or use of any products or other goods sold hereto, whether due to a breach of contract, breach of warranty, the negligence of Graco, or otherwise.

## **FOR GRACO CANADA CUSTOMERS**

The Parties acknowledge that they have required that the present document, as well as all documents, notices and legal proceedings entered into, given or instituted pursuant hereto or relating directly or indirectly hereto, be drawn up in English. Les parties reconnaissent avoir convenu que la rédaction du présente document sera en Anglais, ainsi que tous documents, avis et procédures judiciaires exécutés, donnés ou intentés, à la suite de ou en rapport, directement ou indirectement, avec les procédures concernées.

## Graco Information

For the latest information about Graco products, visit [www.graco.com](http://www.graco.com).

For patent information, see [www.graco.com/patents](http://www.graco.com/patents).

**TO PLACE AN ORDER, contact your Graco distributor or call to identify the nearest distributor.**

**Phone: 612-623-6928 or Toll Free: 1-800-533-9655, Fax: 612-378-3590**

*All written and visual data contained in this document reflects the latest product information available at the time of publication.*

*Graco reserves the right to make changes at any time without notice.*

Original instructions. This manual contains English. MM 3A5410

**Graco Headquarters:** Minneapolis  
**International Offices:** Belgium, China, Japan, Korea

**GRACO INC. AND SUBSIDIARIES • P.O. BOX 1441 • MINNEAPOLIS MN 55440-1441 • USA**

**Copyright 2017, Graco Inc. All Graco manufacturing locations are registered to ISO 9001.**

[www.graco.com](http://www.graco.com)

May 2019