

Hose or Cord and Light Reel Enclosure

3A2828C

EN

Instructions for installing reel enclosure on a Graco Hose or Cord and Light Reel.

A complete list of Models begins on page 2.



Important Safety Instructions

Read all warnings and instructions in this manual and your SD™ and XD™ Series Hose Reel instruction manual or SD™ Series Cord and Light Reel instruction manual. Save all instructions.







ti32048a

Contents

- Contents** 2
- Warnings** 3
- Hose Reel Models** 4
 - Cord and Light Reel Kits 5
- General Installation Information** 7
 - Hose Reel Enclosure Installation 7
- Cord and Light Reel Enclosure Installation** 8
 - Reel Enclosure 12
- Mounting Channel Dimensions** 13
 - 3 Reel Base Weldment 14
 - 4 Reel Base Weldment 14
 - 5 Reel Base Weldment 15
 - 6 Reel Base Weldment 15
 - 3 Reel Base Weldment 17
 - 4 Reel Base Weldment 17
 - 5 Reel Base Weldment 18
 - 6 Reel Base Weldment 18
 - Side Dimension (All Models) 19

Warnings

The following warnings are for the setup, use, grounding, maintenance, and repair of this equipment. The exclamation point symbol alerts you to a general warning and the hazard symbols refer to procedure-specific risks. When these symbols appear in the body of this manual or on warning labels, refer back to these Warnings. Product-specific hazard symbols and warnings not covered in this section may appear throughout the body of this manual where applicable.

 WARNING	
 	<p>MOVING PARTS HAZARD</p> <p>Moving parts can pinch or amputate fingers and other body parts.</p> <ul style="list-style-type: none"> • Keep clear of moving parts. • Do not operate equipment with protective guards or covers removed. • Pressurized equipment can start without warning. Before checking, moving, or servicing equipment, follow the Pressure Relief Procedure in your reel manual. Disconnect power or air supply.
 	<p>ELECTRIC SHOCK HAZARD</p> <p>This equipment must be grounded. Improper grounding, setup, or usage of the system can cause electric shock.</p> <ul style="list-style-type: none"> • Turn off and disconnect power cord before servicing equipment. • Connect only to grounded electrical outlets. • Do not use an extension cord. • Ensure ground prong is intact on power cord.

Hose Reel Models

NOTE:

- For **each reel bank**: order 1 End Panel kit and 1 Mounting Channel kit. Order 1 Side Panel kit for each reel.
- Before installing the Hose Reel Enclosure, you must install the hose on the reel and adjust the spring tension accordingly . See the Hose Reel Installation manual.

HP Models: Enclosed Mounting Channel Kits							
FN	Description	203521 1 Reel	203522 2 Reels	203523 3 Reels	203524 4 Reels	203525 5 Reels	203526 6 Reels
102	SCREW, 3/8 in. - 16 x 5/8 in.	4	8	12	16	20	24
103	WASHER, lock, 3/8 in.	4	8	12	16	20	24
105	CHANNEL, mounting	1	1	1	1	1	1

HS Models: Enclosed Mounting Channel Kits							
FN	Description	24N323 1 Reel	24N324 2 Reels	24N325 3 Reels	24N326 4 Reels	24N327 5 Reels	24N328 6 Reels
102	SCREW, 3/8 in. - 16 x 5/8 in.	4	8	12	16	20	24
103	WASHER, lock, 3/8 in.	4	8	12	16	20	24
105	CHANNEL, mounting	1	1	1	1	1	1

HP Models: Side Panel Kits							
FN	Description	Part Number - Reel Size - Color					
		24A217 - 10 24A218 - 20 White	24A940 - 10 24A945 - 20 Metallic Blue	24A941 - 10 24A946 - 20 Red	24A942 - 10 24A947 - 20 Black	24A943 - 10 24A948 - 20 Dark Blue	24A944 - 10 24A949 - 20 Yellow
301	SCREW, M6 x 1.0 x 20	4	4	4	4	4	4
302	BASE, reel, enclosed, black	1	1	1	1	1	1
303	PLATE, hold down	1	1	1	1	1	1
304	SCREW, 3/8 in. -16 x 5/8 in.	1	1	1	1	1	1
305	WASHER, lock, 3/8 in.	1	1	1	1	1	1
306	SCREW, thumb, 3/8 in. - 16 x 1/2 in.	4	4	4	4	4	4
307	PANEL, side	1	1	1	1	1	1
308	PANEL, side	1	1	1	1	1	1
309	SCREW, #10 - 24 x 5/8 in.	2	2	2	2	2	2
310	NUT, spring	2	2	2	2	2	2
312*	SCREW, M6 x 1.0 x 2.0	4	4	4	4	4	4

HS Models: Side Panel Kits							
FN	Description	Part Number - Reel Size - Color					
		24N331 XD10 24N337 XD20 White	24N332 XD10 24N339 XD20 Metallic Blue	24N333 XD10 24N340 XD20 Red	24N334 XD10 24N341 XD20 Black	24N335 XD10 24N342 XD20 Dark Blue	24N336 XD10 24N343 XD20 Yellow
		301	SCREW, M6 x 1.0 x 20	4	4	4	4
302	BASE, reel, enclosed, black	1	1	1	1	1	1
303	PLATE, hold down	1	1	1	1	1	1
304	SCREW, 3/8 in. - 16 x 5/8 in.	1	1	1	1	1	1
305	WASHER, lock, 3/8 in.	1	1	1	1	1	1
306	SCREW, thumb, 3/8 in. - 16 x 1/2 in.	4	4	4	4	4	4
307	PANEL, side	1	1	1	1	1	1
308	PANEL, side	1	1	1	1	1	1
309	SCREW, #10 - 24 x 5/8 in.	2	2	2	2	2	2
310	NUT, spring	2	2	2	2	2	2
312*	SCREW, M6 x 1.0 x 2.0, pan head	4	4	4	4	4	4

*Provided in kit but not for use with reel. Use FN 301.

HP Models: End Panel Kits		
FN	Description	24A950 - 10 24A951 - 20
401	NUT, spring	12
402	SCREW, 10 - 24 x 5/8 in.	12
403	PANEL, end	2
404	LABEL, Graco logo	2

HS Models: End Panel Kits		
FN	Description	24A950 XD10 24A951 XD20
401	NUT, spring	12
402	SCREW, 10 - 24 x 5/8 in.	12
403	PANEL, end	2
404	LABEL, Graco logo	2

Cord and Light Reel Kits

Enclosed Channel Mounting Kits are available from Graco. Installation instructions are included with the kit. Contact Graco Customer Service for additional information about ordering these kits.

NOTE:

- For **each reel bank**: order 1 End Panel kit and 1 Mounting Channel kit. Order 1 Side Panel kit per reel.
- Before installing the enclosure, adjust the springs tension accordingly. See instructions included in your Reel Installation manual.
- Size 5 Kits include a mounting bracket (311) to allow the reel to be installed in an enclosure.
- Kit 24P164 is required when using an existing SD enclosures with a Size 5 reel.
- Kit 24P880 is required when using an existing SD Series 20 enclosure with a Size 5 reel.
- Kit 24P881 is required when using an existing SD Series 20 enclosure with a Size 10 reel.

Size 5/Size 10 Enclosed Mounting Channel Kits							
FN	Description	203521 1 Reel	203522 2 Reels	203523 3 Reels	203524 4 Reels	203525 5 Reels	203526 6 Reels
101	SCREW, 3/8 in. - 16 x 5/8 in.	4	8	12	16	20	24
102	WASHER, lock, 3/8 in.	4	8	12	16	20	24
103	CHANNEL, mounting	1	1	1	1	1	1

Size 5 and Size 10 Side Panel Kits													
Description													
		Size	Size	Size	Size	Size	Size	Size	Size	Size	Size	Size	Size
		5	10	5	10	5	10	5	10	5	10	5	10
		24N682	24A940	24N683	24A941	24N684	24A942	24N685	24A944	24N690	24A217	24N691	24A943
FN	Description	Metallic Blue		Red		Black		Yellow		White		Dark Blue	
301	SCREW, M6 x 1.0 x 2.0	-	4	-	4	-	4	-	4	-	4	-	4
302	BASE, reel, enclosed, black	1	1	1	1	1	1	1	1	1	1	1	1
303	PLATE, hold down	1	1	1	1	1	1	1	1	1	1	1	1
304	SCREW, 3/8 in. -16 x 5/8 in.	5	1	5	1	5	1	5	1	5	1	5	1
305	WASHER, lock, 3/8 in.	5	1	5	1	5	1	5	1	5	1	5	1
306	SCREW, thumb, 3/8 in. - 16 x 1/2 in.	4	4	4	4	4	4	4	4	4	4	4	4
307	PANEL, side	1	1	1	1	1	1	1	1	1	1	1	1
308	PANEL, side	1	1	1	1	1	1	1	1	1	1	1	1
309	SCREW, #10 - 24 x 5/8 in.	2	2	2	2	2	2	2	2	2	2	2	2
310	NUT, spring	2	2	2	2	2	2	2	2	2	2	2	2
311	BRACKET, mounting, Size 5	1	-	1	-	1	-	1	-	1	-	1	-
312*	SCREW, M6 x 1.0 x 2.0	4	4	4	4	4	4	4	4	4	4	4	4

* Provided with kit but not for use with reel use 301.

Size 5/Size 10 End Panel Kits		
FN	Description	24A950
401	NUT, spring	12
402	SCREW, 10 - 24 x 5/8 in.	12
403	PANEL, end	2
404	LABEL, Graco logo	2

General Installation Information

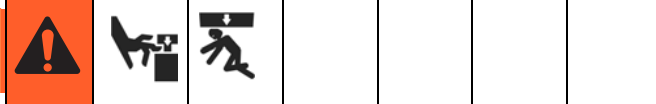

Reels are heavy and may be difficult to mount without assistance. (See Technical Data in all reel installation manuals for the weights of reels and accessories.)

To reduce the risk for injury:

- Be sure the mounting surface and bolts are strong enough to support the reel's weight and stress caused by hard pulls on the accessory.
- When you are mounting a reel overhead, always use a lift truck and **be sure it is secure before lowering the lift truck.**

Hose Reel Enclosure Installation

Unless otherwise noted, reference letters and numbers used in the following instructions, refer to FIG. 15, page 12.

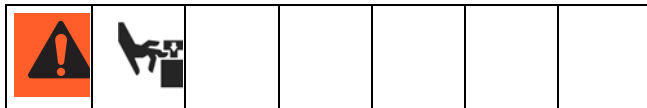

1. Use the mounting channel (103) to lay out the position of the mounting holes before you drill.
2. Drill mounting holes.

NOTE: (SD reels only) Although the hose reel can be installed on the reel base (302) with the guide arm positioned on the left or the right side, there is only one correct installation position. When the hose reel is correctly installed in the reel base, the reel will be centered over the reel base. See FIG. 1 to verify you have installed the hose reel in the reel base correctly.

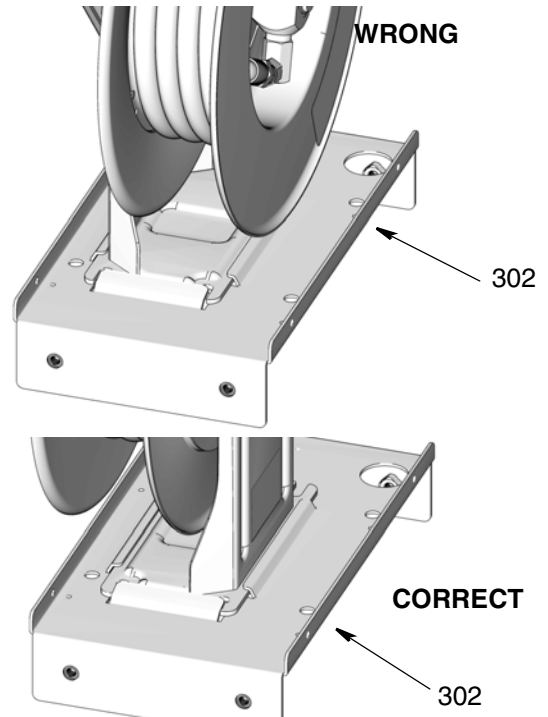

FIG. 1: SD Reels Only

3. Position hose reel on base (302), verifying reel is correctly centered on base as shown in FIG. 1.
4. Install hold down plate (303) using screw (304) and washer (305) (FIG. 2).

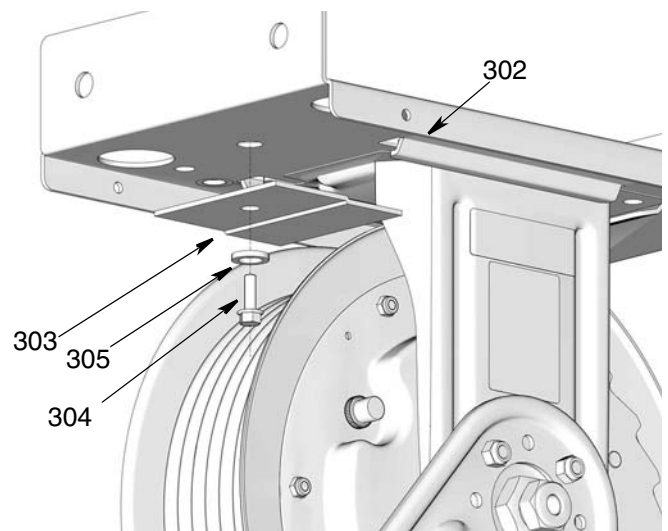

FIG. 2

5. Remove hose stop from hose end and save the parts to reinstall on the hose later (FIG. 3).

Cord and Light Reel Enclosure Installation

Unless otherwise noted, reference letters and numbers refer to FIG. 15, page 12.



NOTE: Additional installation information for models with light accessories and GFCI models are included in the instruction manual provided with your reel.

1. Use the mounting channel (103) to lay out the position of the mounting holes before you drill.
2. Drill mounting holes.
3. Secure mounting channel (103) to mounting surface (FIG. 3).

NOTE: The user must provide four bolts and four washers (A) (FIG. 3) that are strong enough to support the weight of the reel, cord and accessories. See Technical Data in the SD Series Cord and Light Reel instruction manual for the reel's weight without accessories.

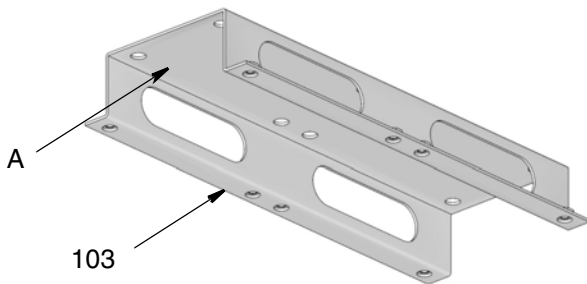

FIG. 3

Size 10 Installation

If installing Size 5 cord reference page 10.

4. Bolt base (302) to channel (103).

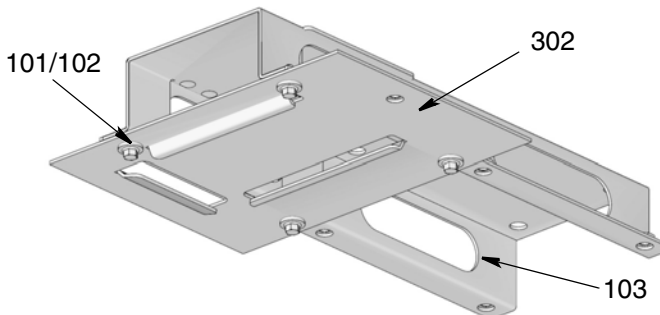

FIG. 4

5. Position reel on base (302), verifying reel is correctly centered on base as shown in FIG. 5

NOTE: Although the reel can be installed on the reel base (302) with the guide arm positioned on the left or the right side, there is only one correct installation position. When the reel is correctly installed in the reel base, the reel will be centered over the base. See FIG. 5 to verify you have installed the reel in the reel base correctly.

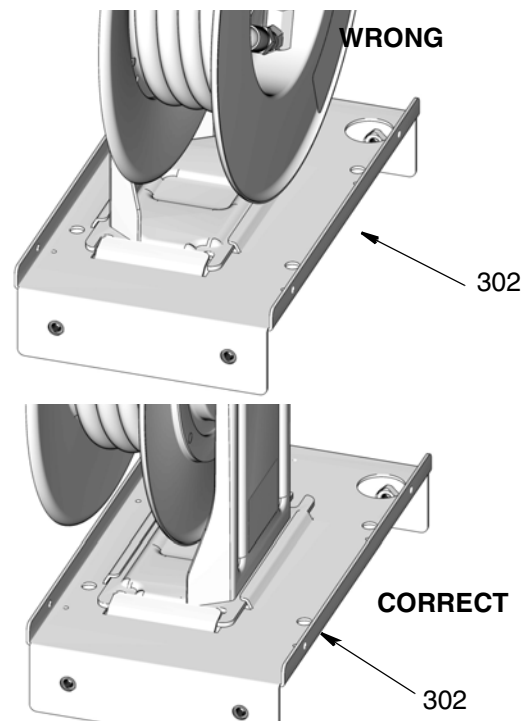

FIG. 5

6. Install hold down plate (303) using screw (304) and washer (305) (FIG. 6).

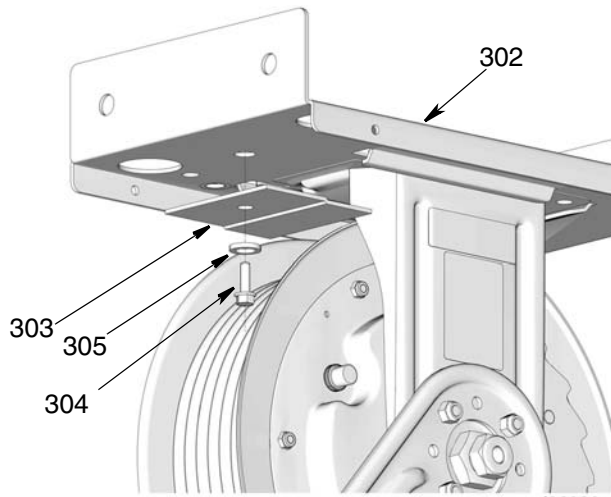

FIG. 6

7. Route power cord through hole (B) in base plate (302) (FIG. 7).

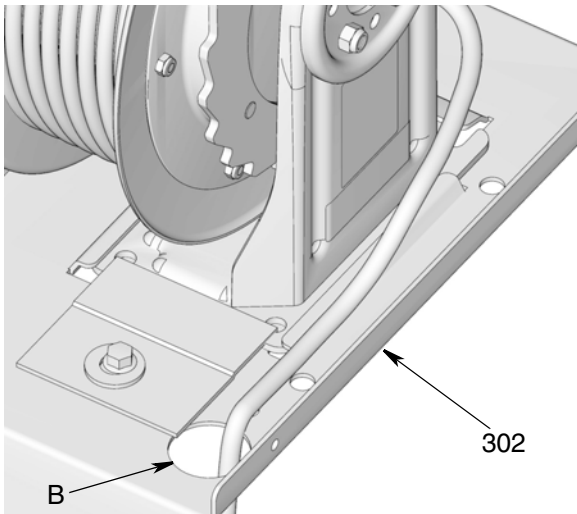

FIG. 7

8. Lock reel. Remove ball stop from cord and put all the parts in a safe place to reinstall later (FIG. 8).
 - a. Loosen and remove screws (aa) and nuts (bb).
 - b. Separate two ball stop components (cc), remove from end of cord.

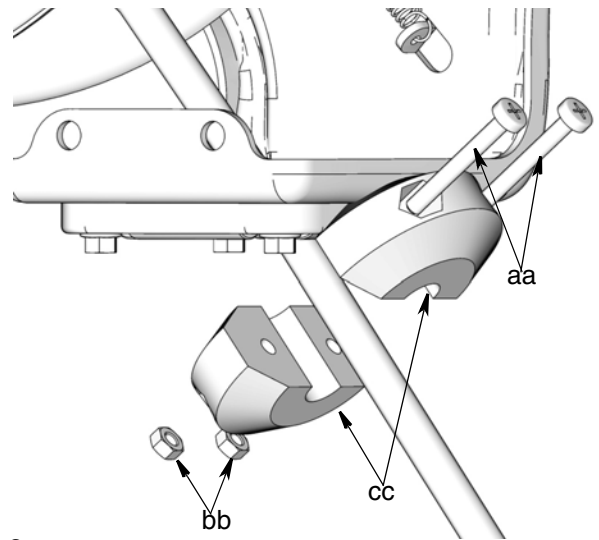

FIG. 8

9. Loosen and remove screws (312) holding reel guide (d) to reel guide arm (c). Completely remove reel guide and cord stop (FIG. 9).

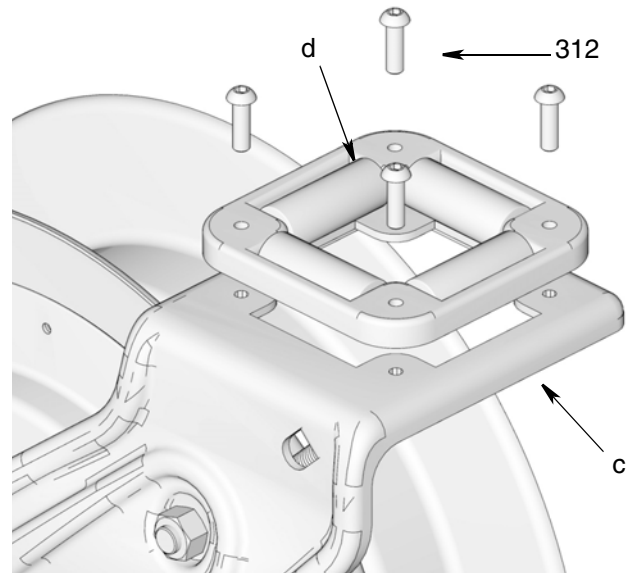

FIG. 9

NOTE: FIG. 10 shows the reel installed on the ceiling bracket.

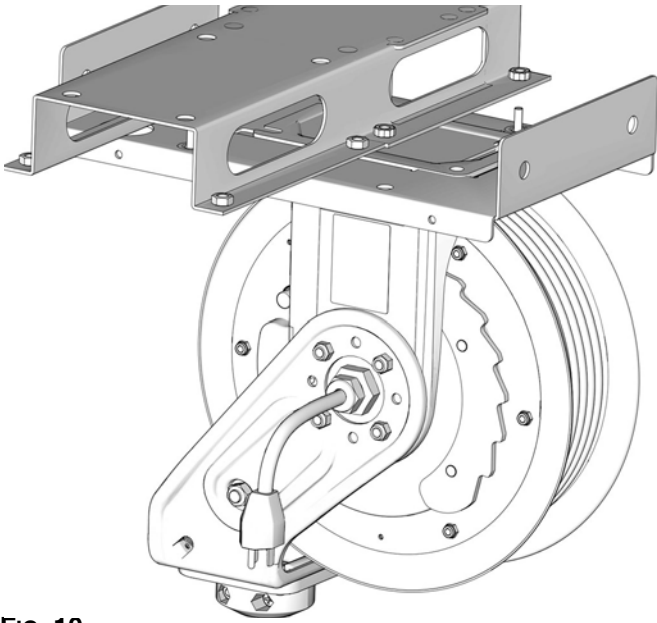

FIG. 10

10. Continue installation with Enclosure Assembly instructions, page 11.

Size 5 Installation

Steps 1 - 3 are provided on page 8.

4. Bolt mounting bracket (311) to base of reel with bolts/washer (304/305). (FIG. 11)

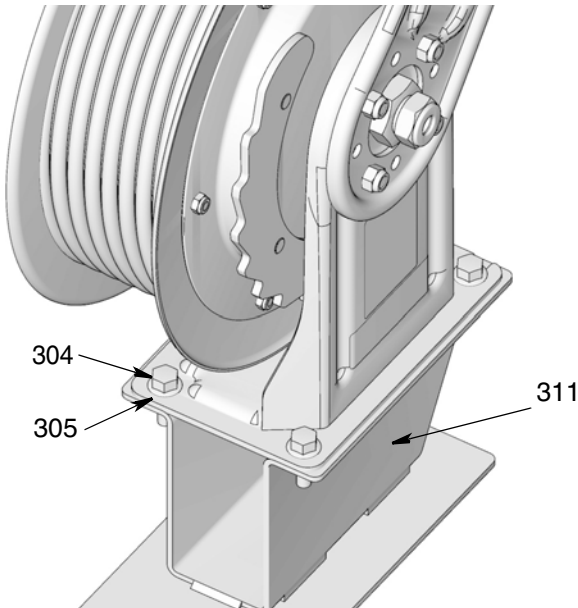

FIG. 11

5. Install mounting bracket (311) into slot of mounting base (302). (FIG. 12)

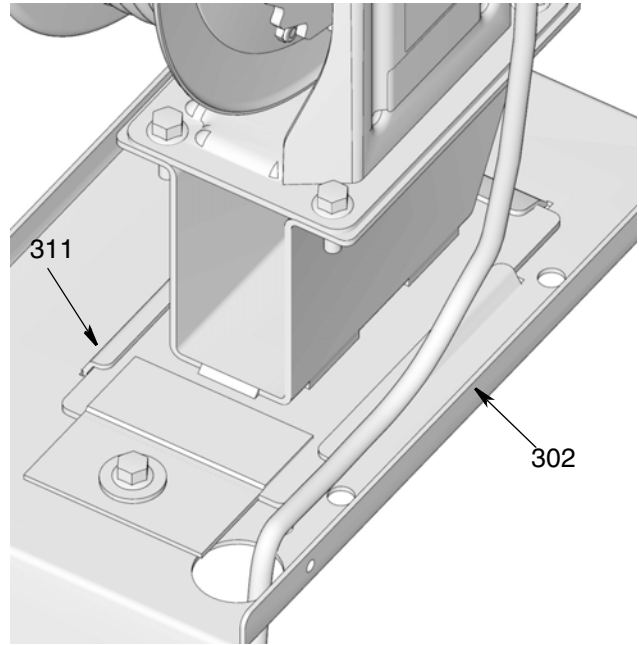

FIG. 12

6. Install hold down plate (303) using bolts/washer (304/305). (FIG. 13).

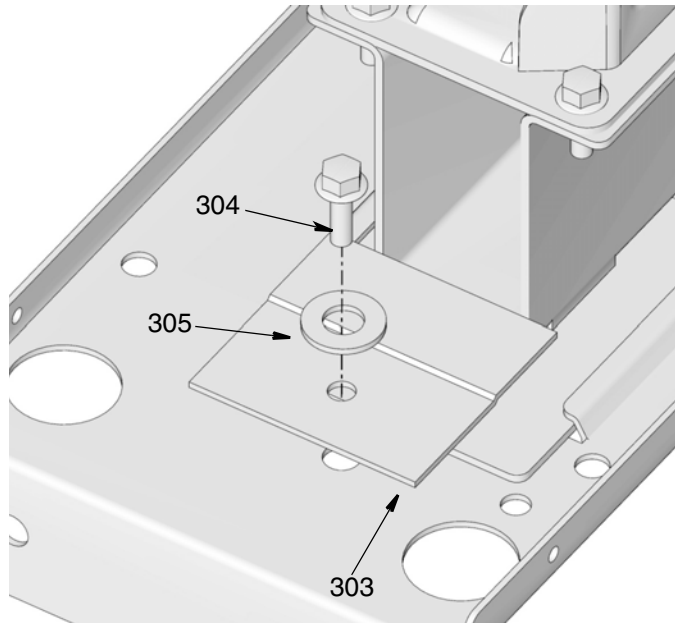

FIG. 13

7. Continue installation with Enclosure Assembly instructions.

Enclosure Assembly

- Slide one spring nut (310) over each position hole (a) on the side panels (307 and 308). Refer to the enlarged view shown in FIG. 15 for proper clip orientation.

NOTE: If installing enclosures on a bank of reels where the alignment is critical, proceed to steps 6 through 10.

- Slide the two panel sections (307 and 308) together to align clips (310)/holes (a) with mating holes (b) in the panel section. Insert and tighten the screws (309) to join the two side panels.

Enclosure Installation

- Place enclosures over reel base (302).
- Install four thumb screws (306), but do not tighten, to join side panels to the reel base (302). Align opening for roller guide (d) in panel (307) with end of guide arm (c).
- Reinstall roller guide (d) to arm through the opening in panel (307). Install and tighten the 4 new screws (301) that came with the kit. Tighten the four thumb screws (306) until they are snug.
- Install panels (308) with the hole for the roller guide with thumb screws (306), but do not tighten, to all reel bases (302) in the reel bank.
- Align the opening for the roller guide in panel (308) with the end of the guide arm (c) then reinstall the roller guide (d) with the four new screws (301) that came with the kit.
- Minor adjustments may be made to achieve proper alignment while tightening the four screws (301) for the roller guide. If more adjustment is needed, proceed to step 8. If alignment is correct, proceed to step 10.
- Start at one end of the reel bank, if the panel is not aligned, loosen the four nuts (g) on the guide arm (c), adjust the arm until the panel is aligned properly with the panel on either side, then tighten the nuts.
- Move to the next panel on the reel bank and repeat adjustments until all of the installed panels are properly aligned.
- Install panel (307) by sliding together with installed panel (308), align clips (310)/holes (a) with mating holes (b) in the panel section, loosely insert the thumb screws (306), then insert and tighten the screws (309) to join the two side panels together.

- Make any final minor adjustments while tightening the thumb screws (306) until they are snug.

NOTE: If installing end panels, continue with steps 12-14. If not installing end panels, continue installation with step 15.

NOTE: When installing side panels on a bank of reels (2 or more) one end panel is installed on each end of the series of reels.

- Slide one clip (401) over each hole (b) on both side panels (307/308). Refer to the enlarged view shown in FIG. 15 for side panels to proper clip alignment.
- Match holes (e) in end panel (403) to mating holes (f) in a side panel. Install and tighten screws (402) to join the end and side panels together.
- Clean and dry off surface of each end panel. Attach a Graco label (404) to the center of each end panel.
- Position ball stop (cc) so hose extends far enough for all operators to reach dispensing valve.
- Insert screws (aa) through ball stop (cc) and hand tighten nuts (bb) to hold cord stop in place. If hose has a warning tag, hose stop should be installed on the same end as the warning tag.

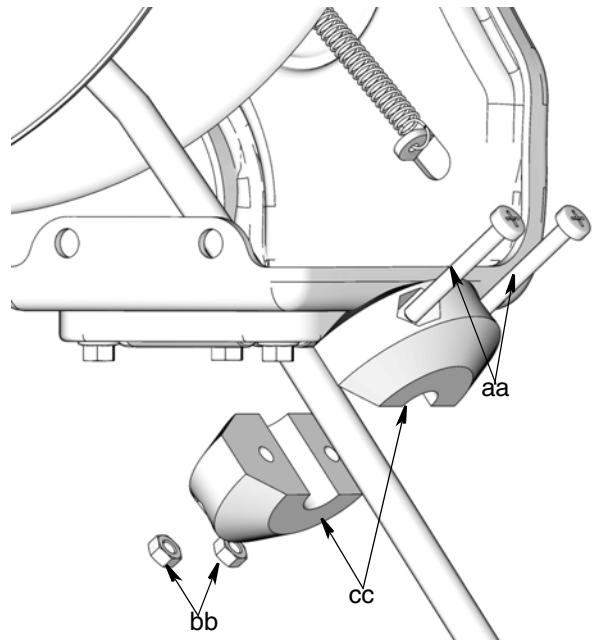

FIG. 14

- Install accessory to end of cord. See SD Series Cord and Light Reel instruction manual or the separate accessory instruction manual for installation instructions.

Reel Enclosure

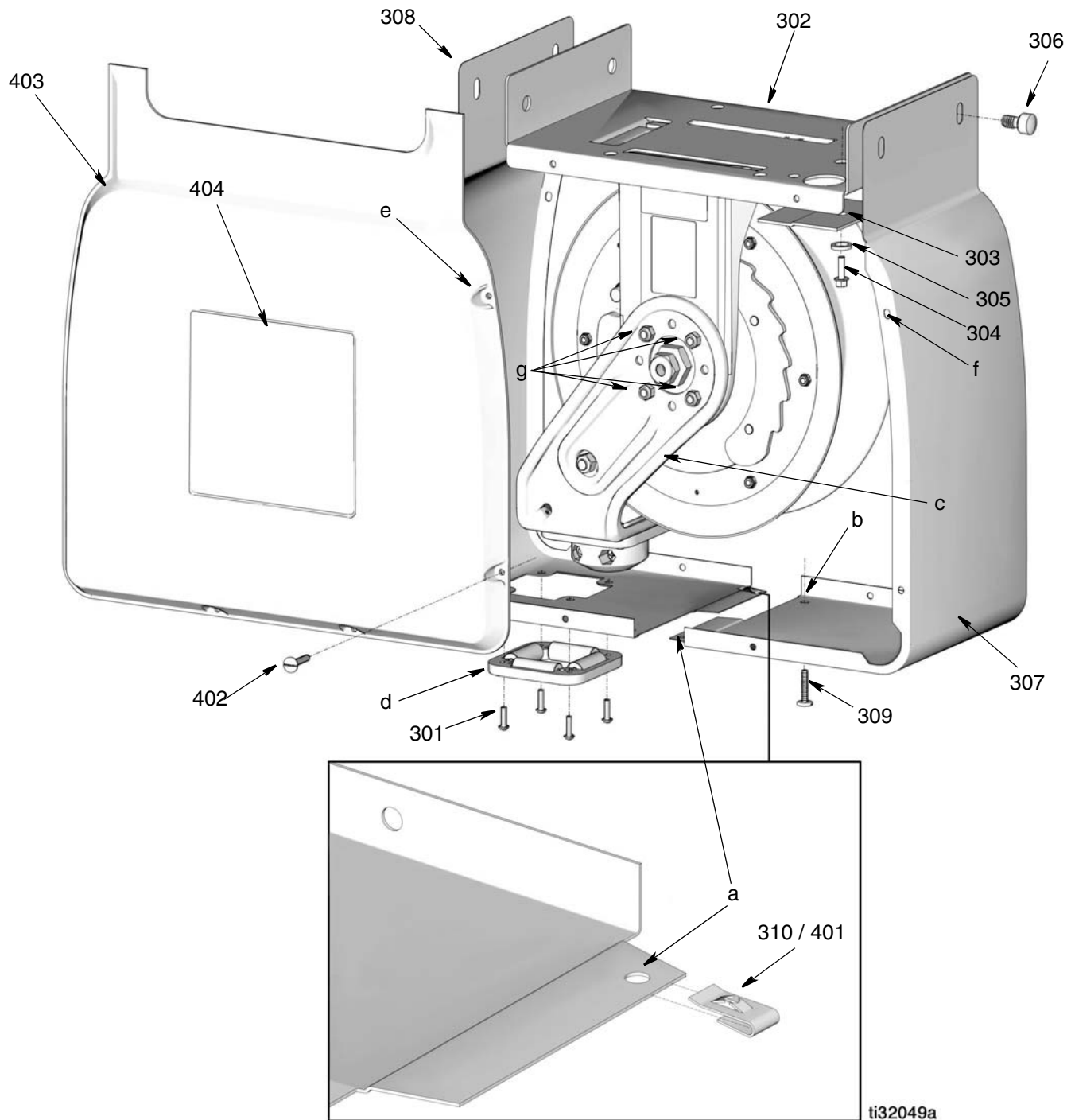
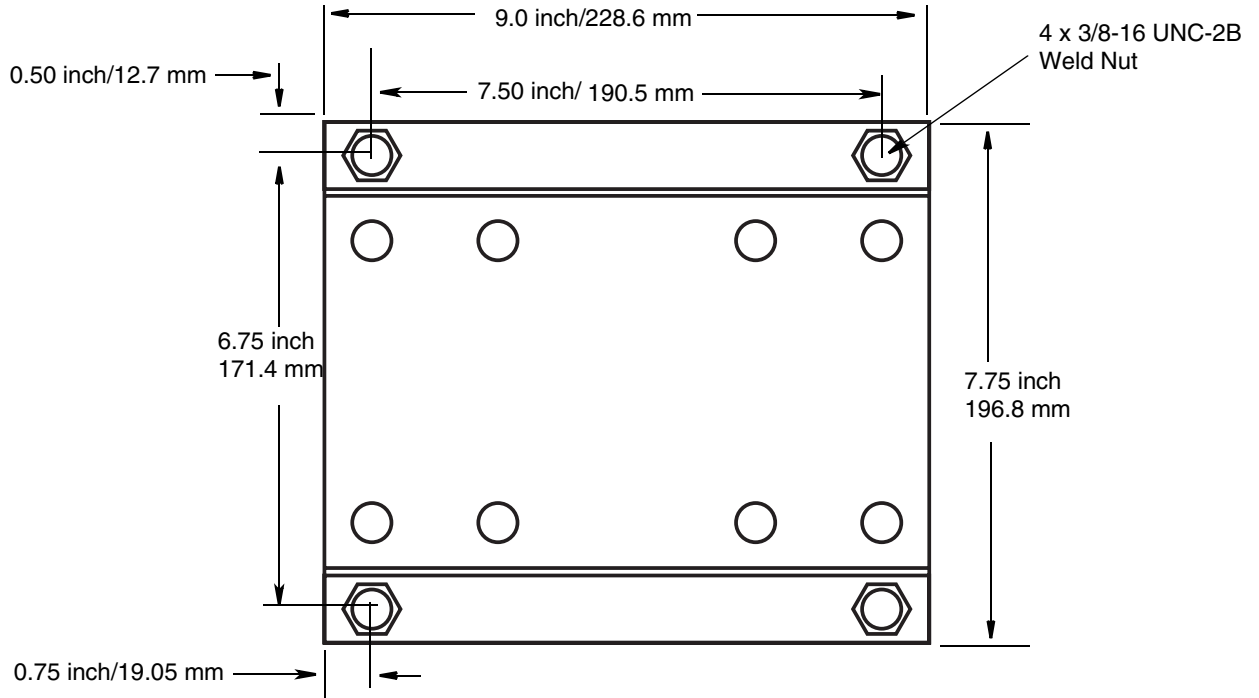

FIG. 15

Mounting Channel Dimensions

(Side dimension for all kits, page 19)

1 Reel Base - Included in Kits 24A934 / 203521



2 Reel Base - Included in Kits 24A935 / 203522

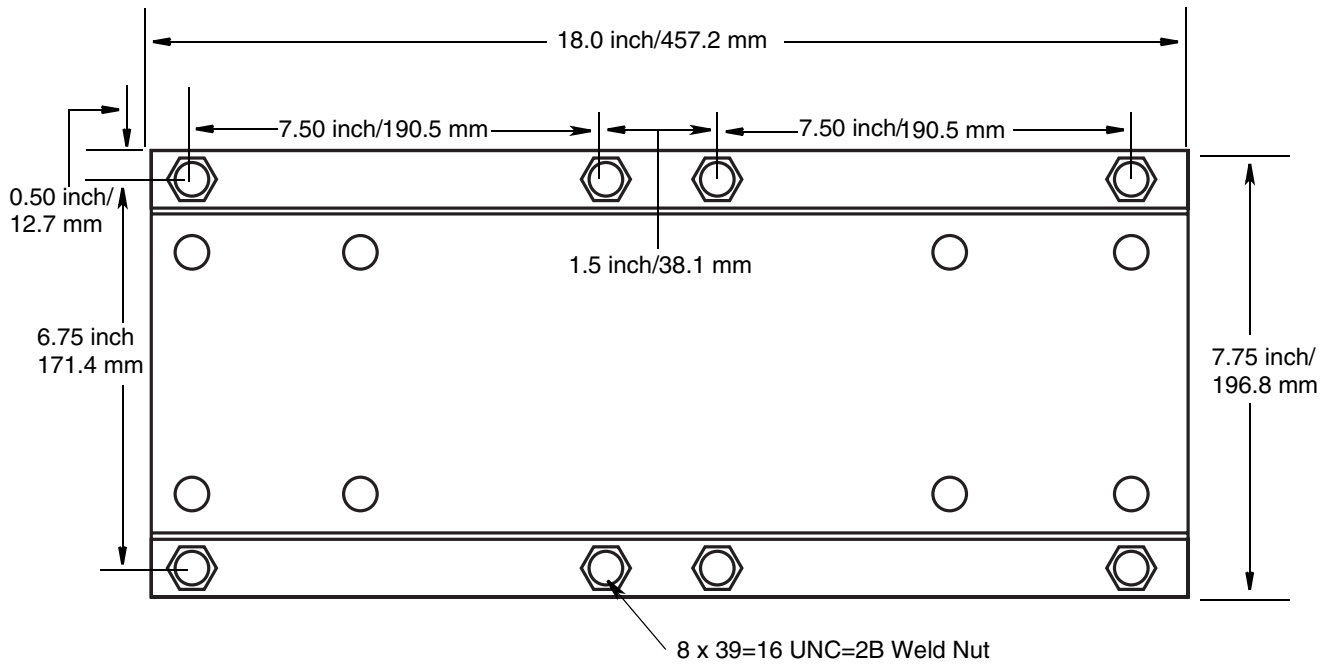

3 Reel Base Weldment

Included in Kits 24A936, 203523

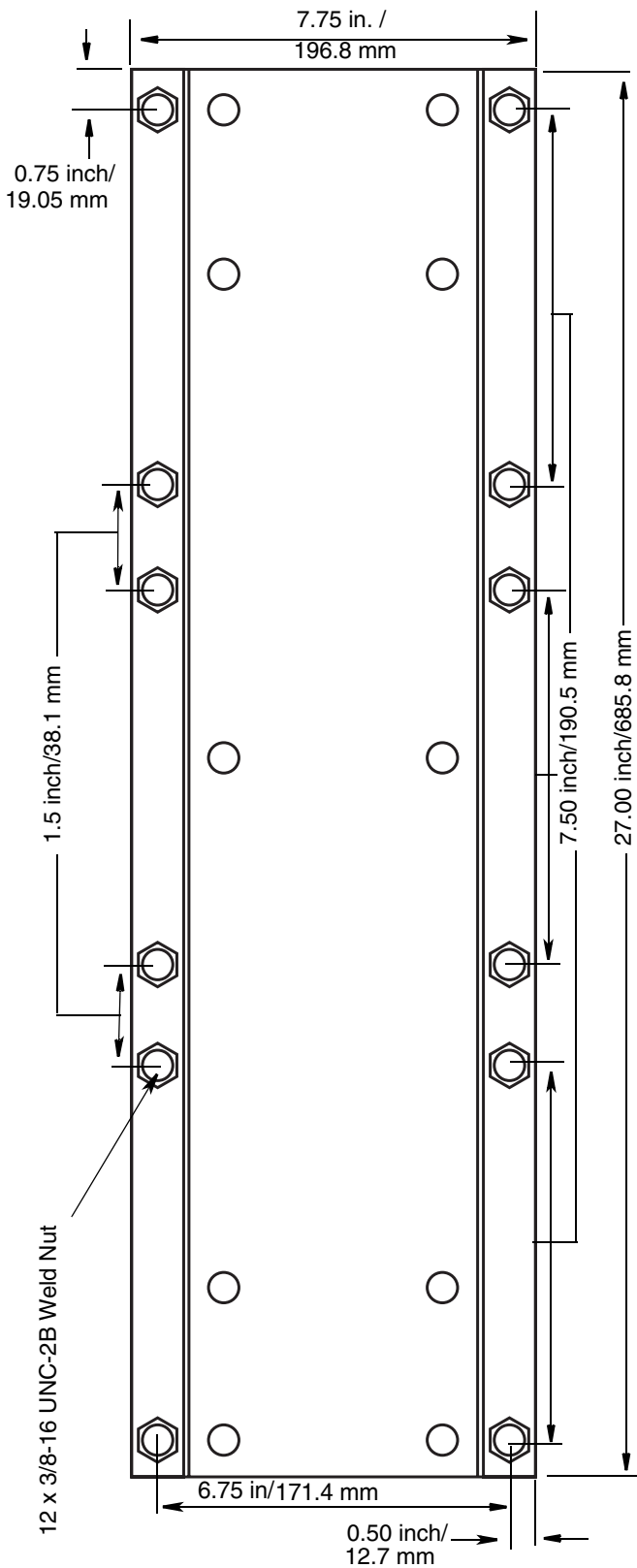

4 Reel Base Weldment

Included in Kits 24A937, 203524

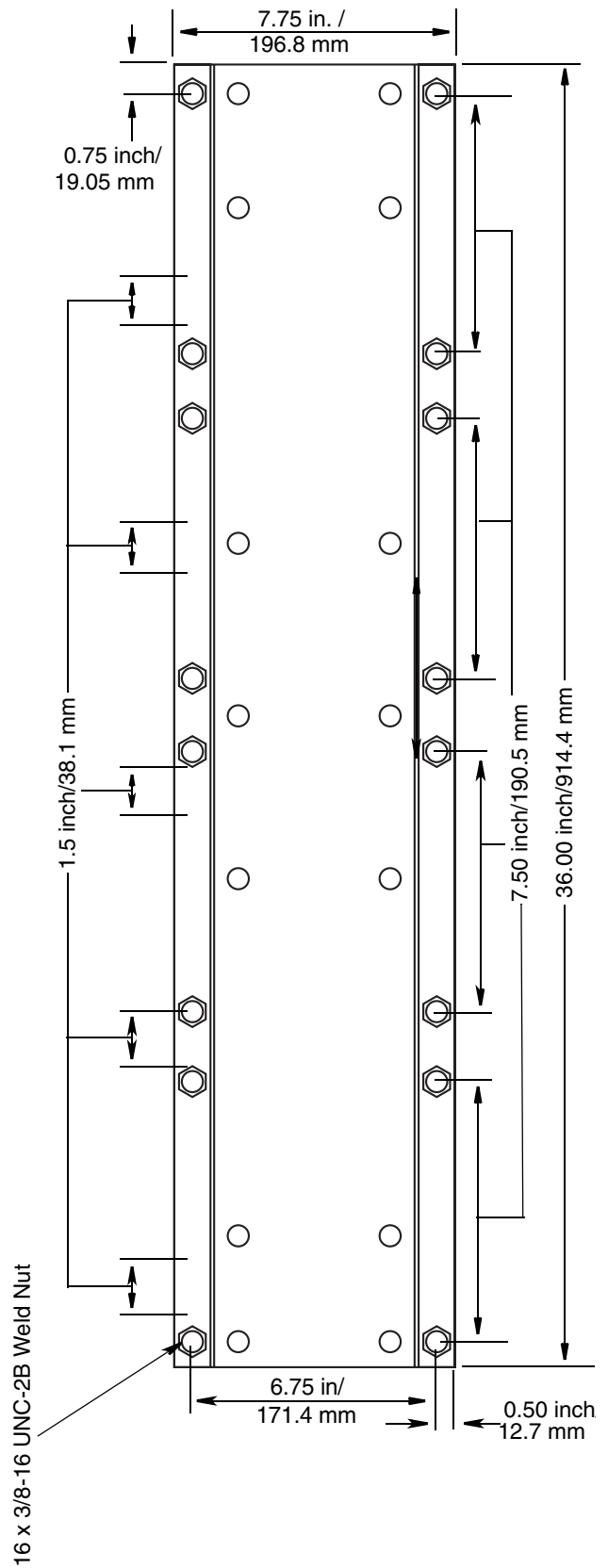

5 Reel Base Weldment

Included in Kits 24A938, 203525

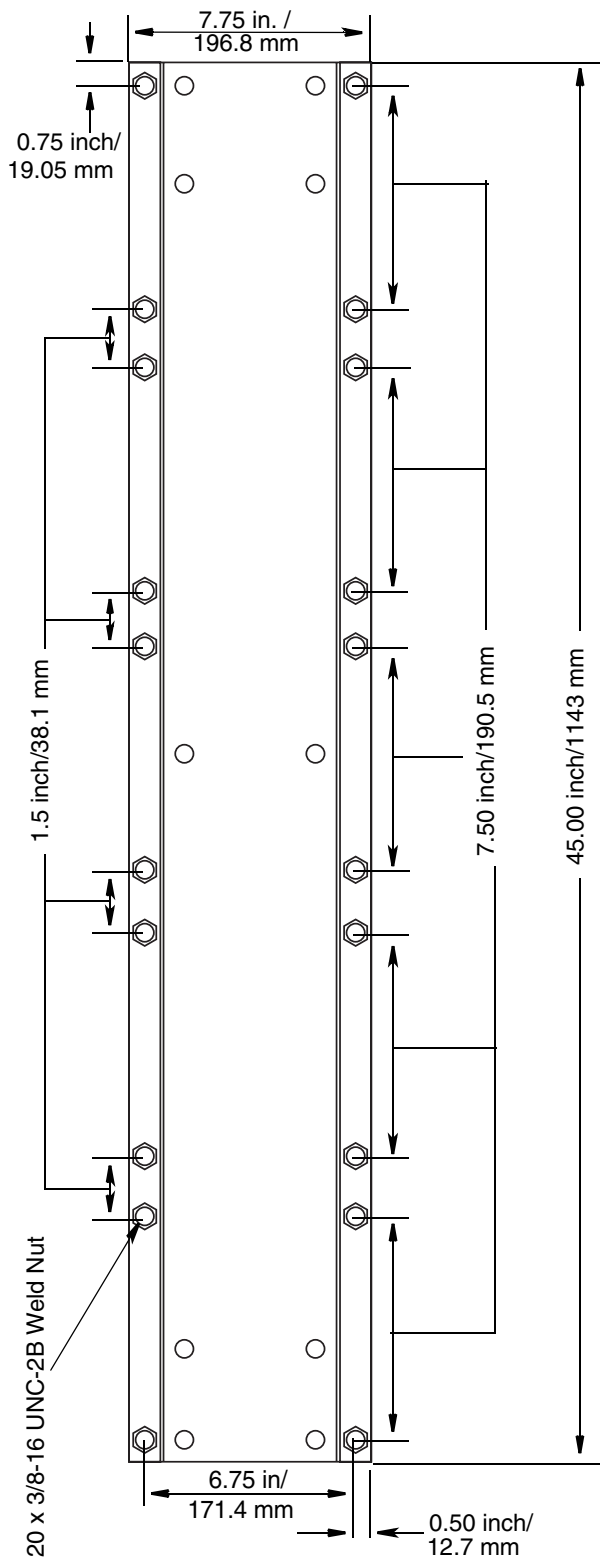

6 Reel Base Weldment

Included in Kits 24A939, 203526

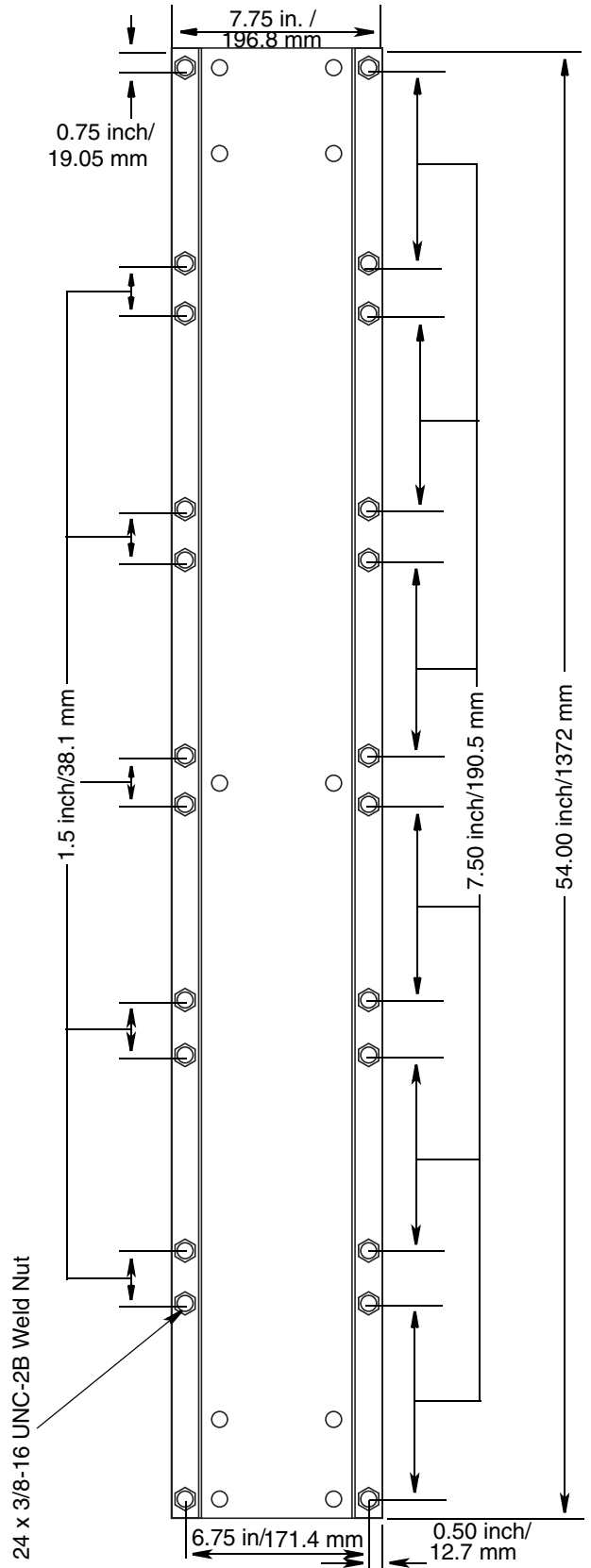

1 Reel Base - Included in Kit 24N323

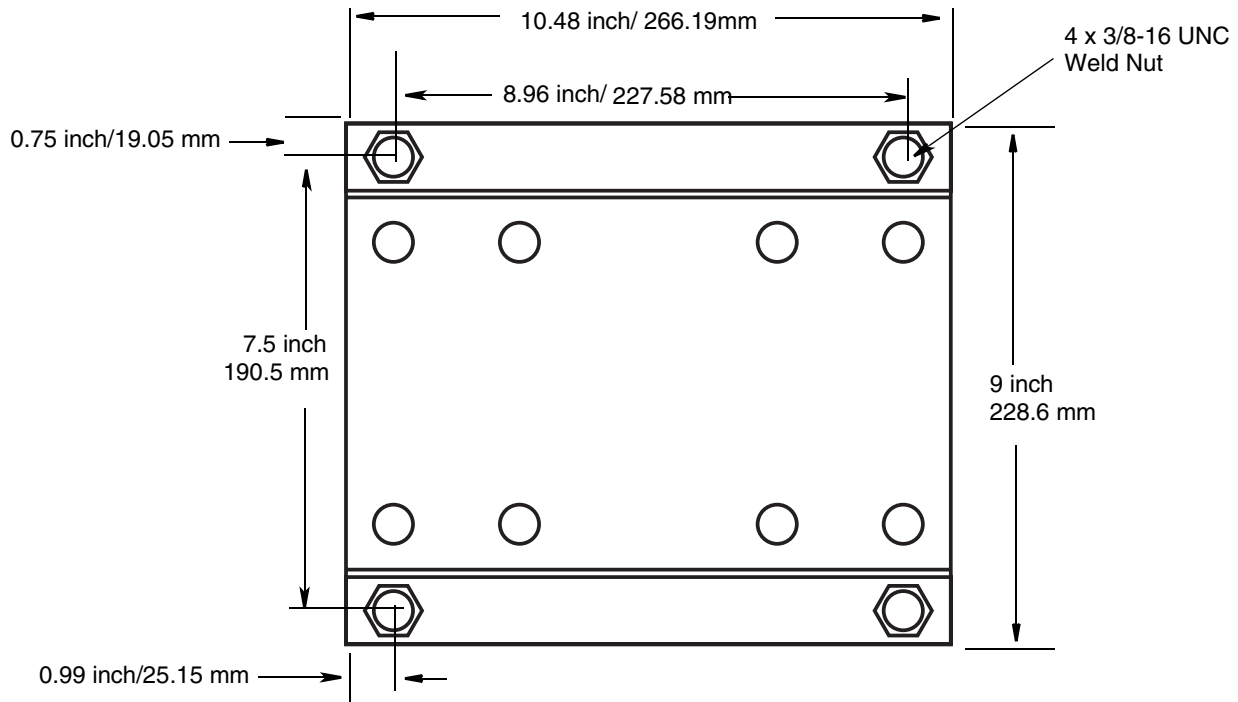

2 Reel Base - Included in Kit 24N324

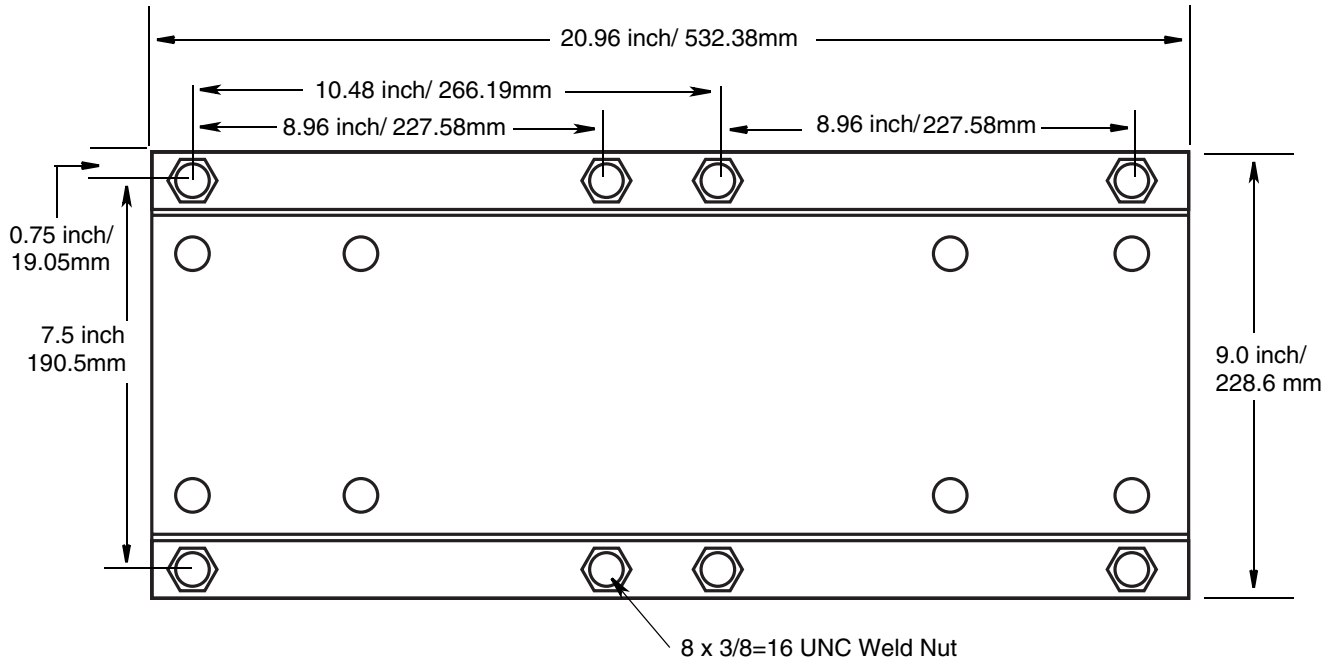

3 Reel Base Weldment

Included in Kit 24N325

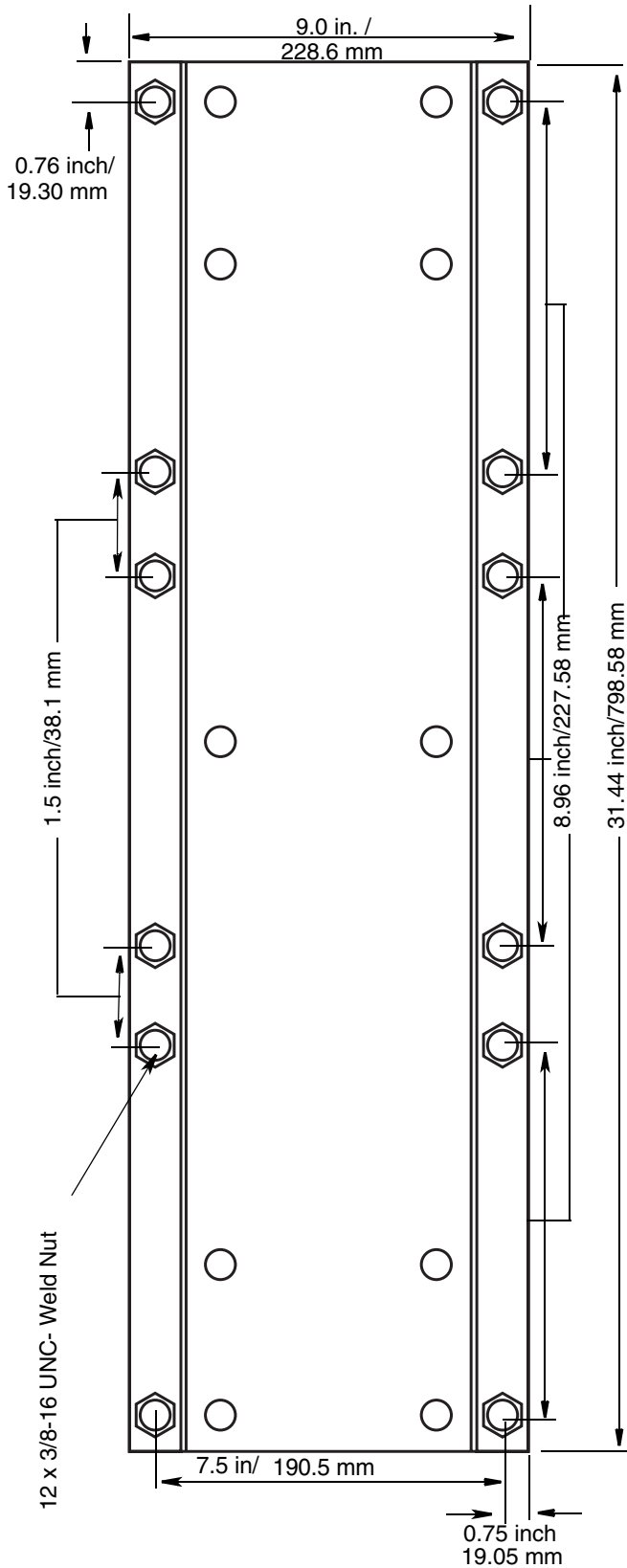

4 Reel Base Weldment

Included in Kit 24N326

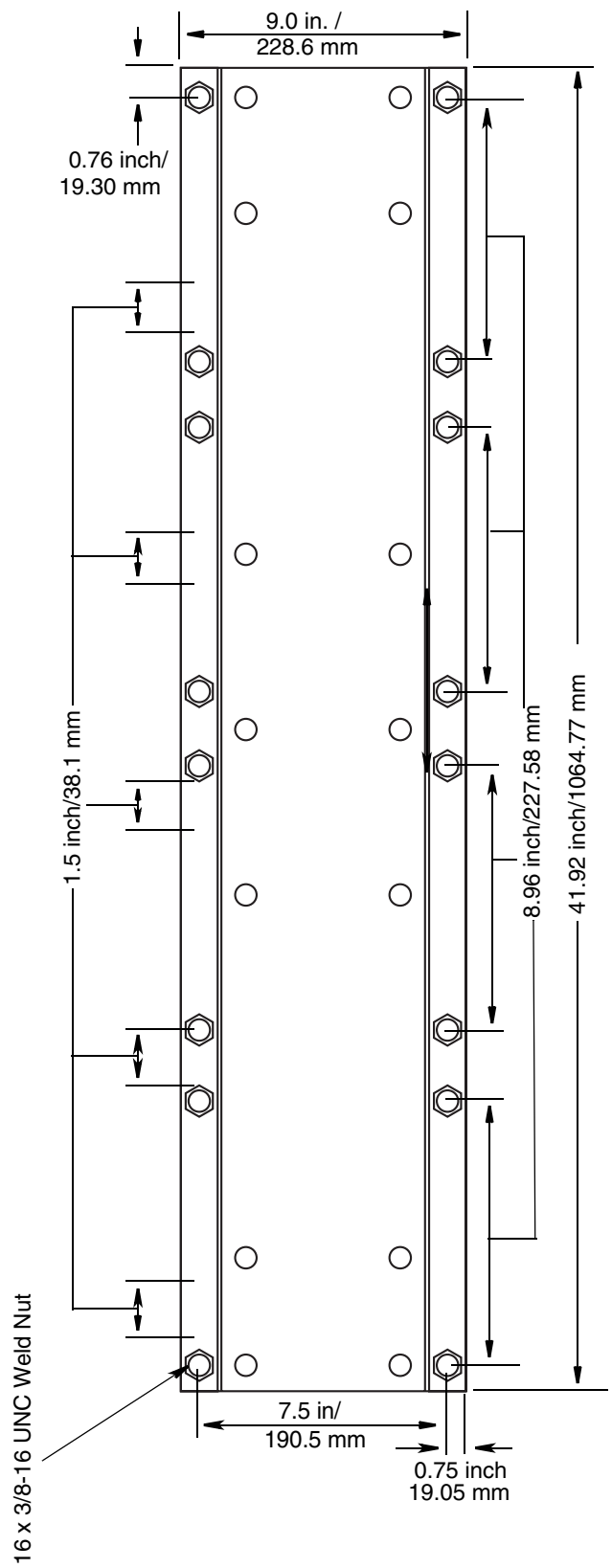

5 Reel Base Weldment

Included in kit 24N327

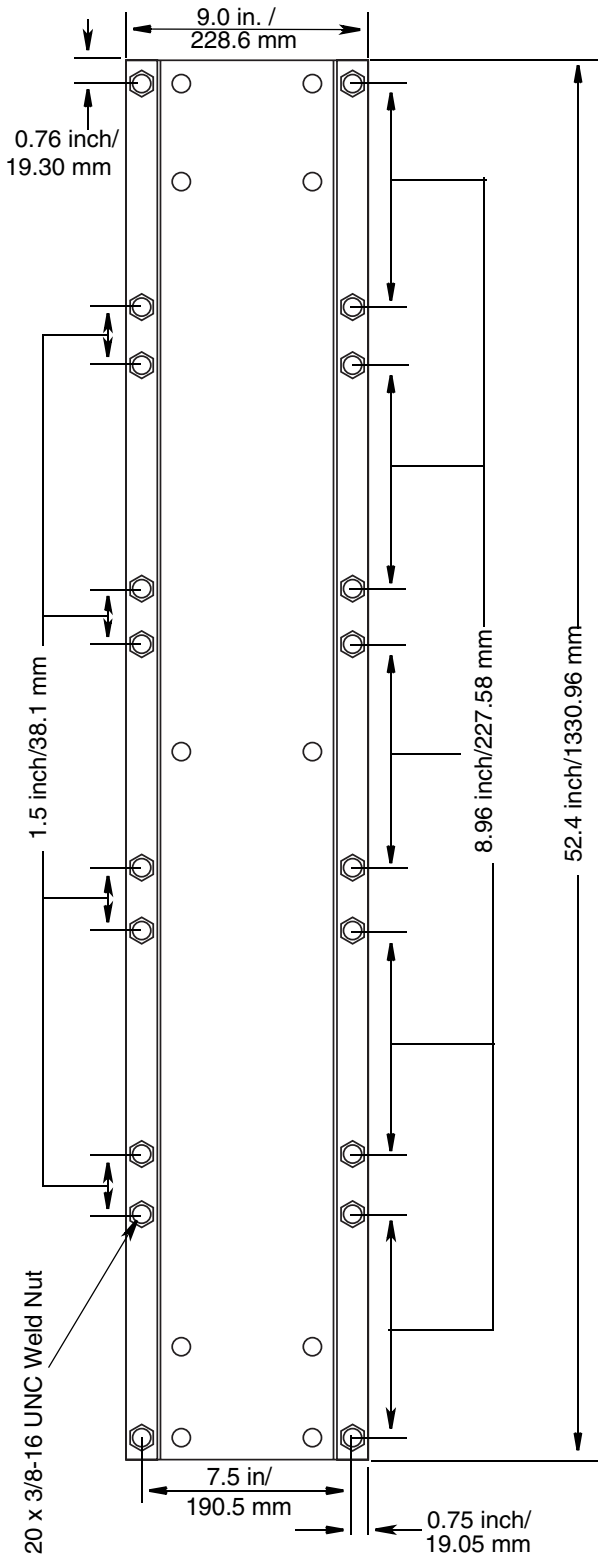

6 Reel Base Weldment

Included in kit 24N328

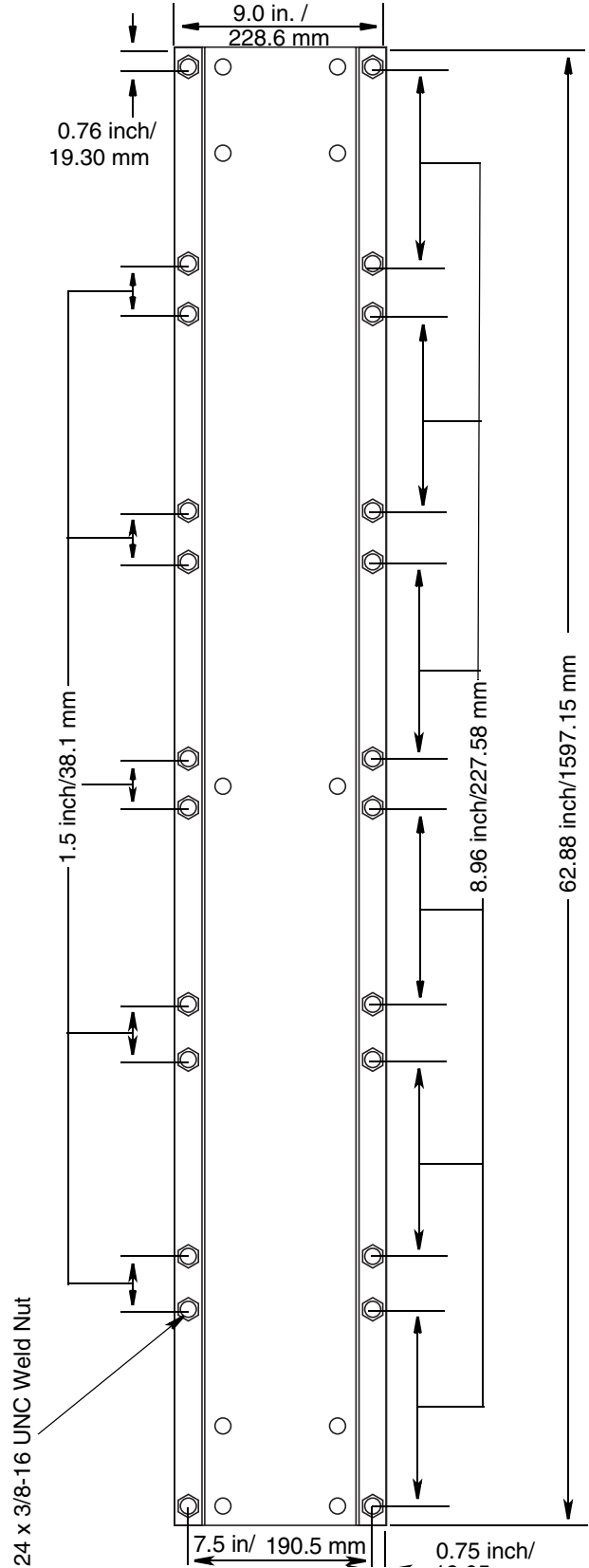

Side Dimension (All Models)

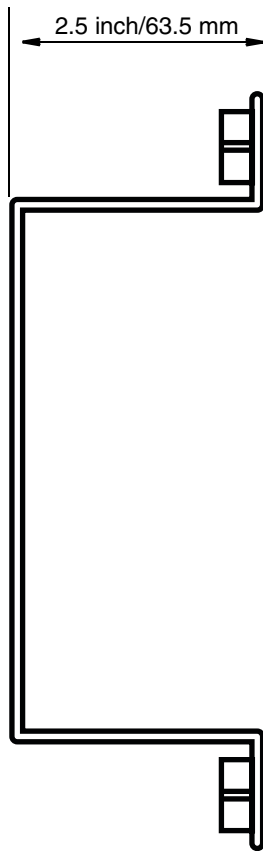

Graco Information

For the latest information about Graco products, visit www.graco.com.

TO PLACE AN ORDER, contact your Graco distributor or call to identify the nearest distributor.
Phone: 612-623-6928 or **Toll Free:** 1-800-533-9655, **Fax:** 612-378-3590

*All written and visual data contained in this document reflects the latest product information available at the time of publication.
Graco reserves the right to make changes at any time without notice.*

For patent information, see www.graco.com/patents.

Original instructions. This manual contains English. MM 3A2828

Graco Headquarters: Minneapolis

International Offices: Belgium, China, Japan, Korea

GRACO INC. AND SUBSIDIARIES • P.O. BOX 1441 • MINNEAPOLIS MN 55440-1441 • USA

Copyright 2012, Graco Inc. All Graco manufacturing locations are registered to ISO 9001.

www.graco.com

April 2019