

TIG-250P ACDC

IGBT INVERTER WELDER

Sep, 2021

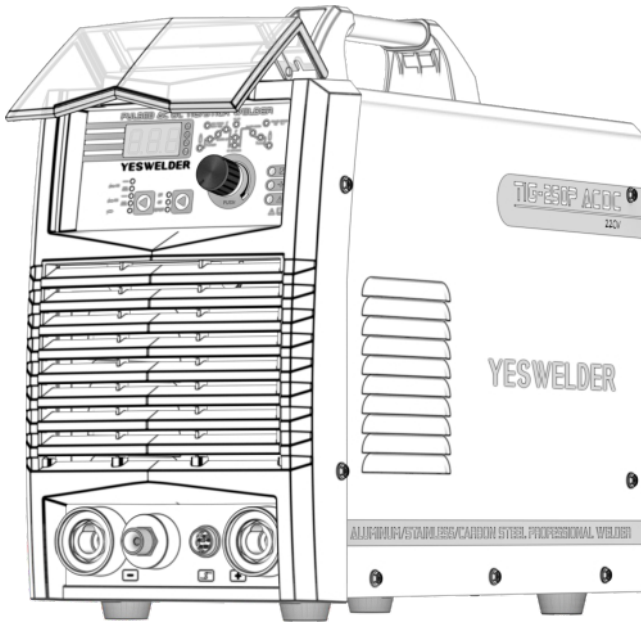

OPERATOR'S MANUAL

YESWELDER®

Copyright © Yeswelder

 To help us serve you better, go to www.YesWelder.com

Thanks for your purchase of this series of welder products! This series of products are safe, reliable, firm, durable, convenient to maintain, and capable of greatly raising the welding productivity. This user's manual contains important information on the use, maintenance and safety of the product. See the technical parameters of the equipment in Technical Parameter in this manual. Please go through this manual for the first use. In order to ensure the personal safety of the operator and the safety of the working environment, please read the safety attentions in this manual carefully, and operate according to the instructions.

DECLARATION

Hereby we declare that these machines are produced based on relative Chinese and international standards and they conform to the international safety standard IEC974. The design and technology adopted in these machines are under patent protection.

Please read and understand this manual carefully before the installation and operation of these machines.

1. The contents of this manual may be revised without prior notice and without obligation.
 2. Although carefully checked, there may still be some inaccuracies in this manual. Please consult us if any.
 3. This manual is issued in May 2020.
-

Notes:

To avoid loss and personal injury, please be careful with the parts with “NOTE!”. Go through these chapters and articles, and operate according to this manual.

CONTENTS

1. SAFETY	01-02
2. SYMBOL EXPLANATION	02-03
3. PRODUCT OVERVIEW	04
4. FUNCTION OVERVIEW	04-05
5. PERFORMANCE CHARACTERISTICS	05-06
6. OUTPUT VOLT-AMPERE CHARACTERISTICS	07
7. TECHNICAL PARAMETERS	07-08
8. ELECTRICAL SCHEMATIC DIAGRAM	09
9. OPERATION DESCRIPTION	10
9.1 Machine appearance description.....	10
9.2 Panel description.....	10-12
9.3 Keys Operation Description.....	12
9.3.1 Welding Mode Selection	12
9.3.2 Welding Torch control mode selection	13
9.3.3 Welding Parameters Setting	14-15
9.4 Welding Mode Description.....	15
9.4.1 MMA.....	15-17
9.4.2 DC TIG welding.....	17-18
9.4.3 Pulsed TIG welding	18
9.4.4 AC square wave TIG welding	19
9.4.5 AC pulsed TIG welding.....	19-20
9.5 TIG operation mode	20-21
10. INSTALLATION & OPERATION	22
10.1 Installation	22
10.2 Operation	22-23
10.3 TIG Welding Torch	24
11. CAUTION	25
11.1 Working Environment	25
11.2 Safety Tips	25
12. BASIC KNOWLEDGE OF WELDING	26
12.1 Basic knowledge of MMA	26
12.1.1 Welding Process of MMA	26
12.1.2 Tools for MMA	26-27
12.1.3 Basic Operation of MMA	27-29
12.2 Argon arc welding	29
12.2.1 General description of argon arc welding.....	29-30
12.2.2 Characteristics of argon arc welding	30
12.2.3 Gas tungsten arc welding (GTAW).....	30-31
12.2.4 GTAW process	31-33
12.2.5 Welding process parameters	33-34
12.2.6 General requirements for argon arc welding	34
13. OPTIONAL ACCESS OPERATION DESCRIPTION	35
13.1 Pedal Remoter Operation	35
13.2 Wire-drive Welding Torch Operation	36-37
14. MAINTENANCE	37
15. TROUBLESHOOTING	38
15.1 Common Malfunction Analysis and Solution	38-40
15.2 Alarm and Solutions (Table 15-3)	40-41
APPENDIX A: TRANSPORTATION AND STORAGE	41
A1. Transportation.....	41
A2. Storage	41
APPENDIX B: WIRING DIAGRAM OF COMPLETE MACHINE	42

1. SAFETY

Welding may result in injury to you and others, so please implement protection during welding. See more details in Safety Protection Guidebook for Operator which meets the requirements to manufactures on accident prevention.



Operate this equipment by trained professional only!

- Use welding labor protection supplies with approval of safety supervisory authority.
- Operators must be the special workers with valid work permits of “Metal Welding (Gas Cutting) Operation”.
- Do not maintain and repair welder with power.



Electric shock-may result in serious injury or even death!

- Install grounding device according to application standard.
- Do not touch live parts with naked skin, wet gloves or wet clothes.
- Be sure you are insulated from ground and workpiece.
- Confirm the safety of your working position.



Smoke-may be harmful to your health!

- Keep your head away from the smoke to avoid inhalation of waste gas in welding.
- Keep the working environment well ventilated with exhaust or ventilation equipment when welding.



Arc radiation-may hurt your eyes and burn your skin!

- Use proper welding mask and wear protective clothing to protect your eyes and body.
- Use proper mask or curtain to protect onlooker from being injured.



Improper use and operation may result in fire or explosion

- Welding spark may result in fire, so please make ensure there are no inflammables near the welding position, and pay attention to fire safety.
- Ensure there is fire extinguisher nearby, and make sure someone has been trained to operate the fire extinguisher.
- Do not weld closed container.
- Do not use this machine for pipe thawing.



Hot workpiece can cause severe scald.

- Do not touch hot workpiece with bare hands.
- Cool the welding torch for a while after continuously working.



Excessive noise does great harm to people's hearing.

- Wear ear covers or other hearing protectors when welding.
- Give warning to onlooker that noise may be potentially hazardous to hearing.



Magnetic field can make cardiac pacemaker a bit wonky.

- People with cardiac pacemaker should stay away from the welding spot without first talking to a doctor.



Moving parts may injure your body.

- Please keep away from moving parts (like fan).
- Each door, panel, cover, baffle plate, and protective device the like should be closed and located correctly.



Seek professional support when trouble strikes.

- When trouble strikes in installation and operation, please inspect according to related contents in this manual.

2. SYMBOL EXPLANATION

WARNING



Cautions in operation



MMA



Items need special instruction



Welding gas related parameters



It's forbidden to dispose electric waste together with other ordinary waste. Please take care of our environment.



Power on



Power off



Ground connection



PUSH

Rotary knobs allow for key-push operation



Remote control mode or torch control mode



Diameter of Tungsten needles or electrodes



Parameters setting warning



TIG



Arc Force

T...

Spot welding time

PULSE
Hz

Pulse Frequency

setup
% I1

Pulse Width

AC Hz

AC Frequency



AC Balance

A

Current Unit

S

Time Unit

%

Balance Unit or Pulse Width Unit

Hz

AC Frequency or Pulse Frequency Unit

3. PRODUCT OVERVIEW

TIG-250P ACDC is numerical controlled inverter AC DC welder of advanced technologies, multiple functions and excellent performance. Equipped with **AC square wave argon arc welding, AC pulse argon arc welding, DC argon arc welding, DC pulse argon arc welding, DC flux-coated electrodes MMA, and argon arc spot welding (DC, pulse or AC)**, and it's widely applied for various metal materials' delicate welding. The integration of unique electric structure with air channel design in **TIG-250P ACDC** series can speed up the heat dissipation of the power device, so that to improve duty cycle. The unique air channel heat dissipation efficiency can effectively prevent damages for the power devices and control circuits resulted from the dust absorbed by the fan, and greatly improve welder's reliability thereby.

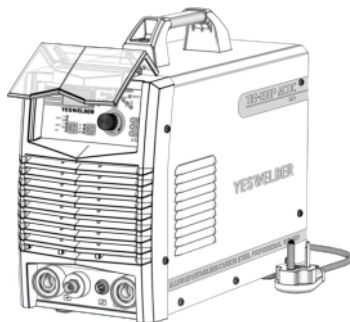

The overall streamline design perfectly integrates front and back panels, forming the most coherent and naturally joints of the machine. The front panel and the rear panel are coated with **rubber oil** to achieve soft texture, fine hand feeling, and warm and pleasant appearance. Optimized welding performance, integration of various welding functions, combination of high efficiency with small size, lightweight, low cost makes it suitable for both heavy industries and open field operation. No matter you are a experienced welding operator or newly started operators, **TIG-250P ACDC** would be your most convenient choice to meet your requirements for various industries and fields.

Not applicable to all products. There might be differences among different machines based on different customer requirements.

4.FUNCTION OVERVIEW

Multi Functions Design

- Multiple welding modes and torch control modes; pedal remoter and welding torch remote control are available;
- Real time display of welding current: convenient display of welding output status.
- MMA hot start function: easier and more reliable MMA arc start
- VRD(optional): to ensure operator's safety while in idle mode
- Anti-sticking(optional): lower the machine's working intensity
- Self-adjustable arc force current: ensure well operation while under long-distance welding.

- HF arc start: built-in pressurized arc ignition circuit; also applicable to TIG no-HF arc ignition.
- Fan intelligent temperature control: prolong the fan's lifespan.
- Auto saving of welding parameters while power off; auto recovery of last time's welding parameters.

5. PERFORMANCE CHARACTERISTICS

IGBT inverter technology

- The adoption of 43 KHz inverting frequency and strong shock resistance IGBT for main loop contributes to smaller welder size and lighter weight, and higher reliability.
- Great reduction in copper and core loss greatly enhances the welding efficiency and saves energy.
- Switching frequency is beyond audio frequency, which almost eliminates noise pollution.

Cutting-edge control technique

- Advanced control scheme caters for various welding process requirements and greatly enhances welder performances.
- New control technology contributes to a smaller voltage spike which is caused by second inversion, thus higher reliability and efficiency as well as smaller size.
- The adoption of MCU intelligent digital control technology and software digital controlled core welding functions bring upgraded performances when compared with traditional welders.
- Applicable to various acid and basic electrodes with a diameter of 1.6mm~4.0mm.
- Easy arc starting, less spatter, stable current and good shaping.

Nice shape and structure design

- Streamline design for front and rear panels to achieve a better integral shape. Panels made of high intensity engineering plastics guarantee high work efficiency in case of strong impact and drop or other harsh conditions. Excellent insulating property.
- Three proofing design; fine antistatic and anticorrosion performance.

Optimized auto protection

- TIG-250P ACDC is of optimized auto protection function. When there is large scale voltage fluctuation, welder will shut off automatically and display the failure information; welder will restart when network voltage is stable. Welder will shut off in case of over-current, over-heat, or other abnormalities, and display the according failure information. Multi protections largely prolong welder's lifespan.

Excellent consistency and performance

- This product adopts intelligent digital control technology which is not sensitive to component's parameters' change; certain components' changes won't affect welder's performances. It's also insensitive to temperature and humidity. All the above contributes to better consistency and performances when compared with traditional welders.

Friendly interaction interface

- This welder adopts international diagram form display, which is easy to understand and convenient to achieve accurate operation for different types of users.

Capable of high quality MMA welding

- The adoption excellent control algorithm largely improve MMA welding performance, bringing easy arc start, stable current, minimum spatter, no sticking, good shaping and self adaption to different cable length and cross-section.

Capable of highly demanding argon arc welding

- Optimized digital CC adjustment technology guarantees low noise and stable arc; meanwhile accurate control technology provides convenient operation for welding current. This welder is capable of 2T/4T/spot welding to meet various welding process demands.

Remote control is available

- This welder is capable of pedal remote control, allowing operator's control on real time welding current even further than 10m.**(The foot pedal need to purchase separately)**

Perfect auto memory

- This welder can automatically save accumulated starting up time, accumulated power-on time, accumulated welding time, accumulated argon arc welding time, accumulated MMA welding time, accumulated alarm time, accumulated over-heat time, accumulated undervoltage time, accumulated over-voltage time, etc. to FLASH memorizer so that to provide data for possible maintenance.

6. OUTPUT VOLT-AMPERE CHARACTERISTICS

This welder is of CC output characteristics. The volt-ampere characteristic shows max output voltage and max output current. All other welding parameters are within the curve range. Please note the volt-ampere characteristics curves of various welding modes in below.

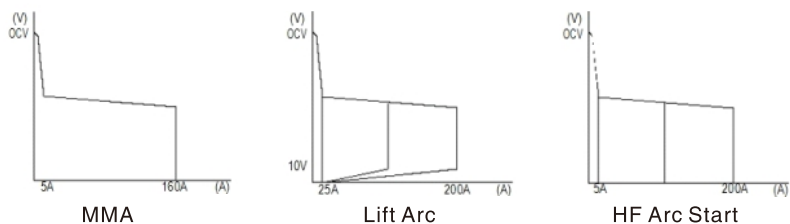

Volt-ampere Characteristics Curve

Note: Lift arc is not a standard function but instead is depending on customer's actual requirements.

7. TECHNICAL PARAMETERS

Model		TIG-250P ACDC
Supply voltage(VAC)		Single phase AC220V±10% 50/60Hz
Input frequency(Hz)		50/60Hz
Rated input peak current(A)		30A
Power capacity(KVA)		6KVA
Rated output current(A)	MMA	200A
	TIG	250A
Output current range	MMA	10~200A
	TIG	5~250A
Arc force current range		0-50
Spot welding time(S)		0.5-10
No load voltage	With VRD	9V
	Without VRD	56V
Pre-flow time(S)		0.1-10
Up-slope time(S)		0-10
Initial current(A)		5-160

AC output frequency(Hz)		20~250
Balance(%)		15-85
Down-slope time(S)		0-15
Post- flow time(S)		0.5-15
Background current(A)		5~250
Pulse frequency(Hz)		0.2~200
Pulse width(%)	0.2Hz~9.9Hz	1~99
	10Hz~200Hz	10~90
Remote control		YES
Arc start		HF Start
Efficiency (%)		85
Duty circle(%)		60%
Power Factor		0.7
Insulation grade		F
Enclosure protection class		IP21S

8. ELECTRICAL SCHEMATIC DIAGRAM

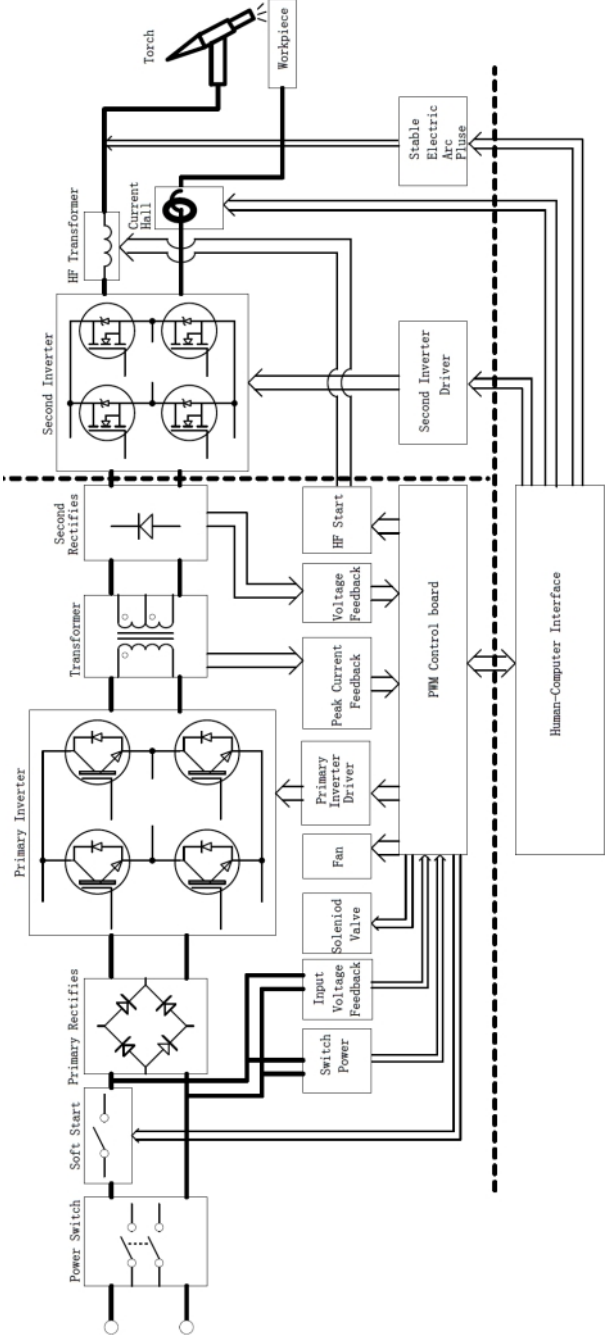

9. OPERATION DESCRIPTION

9.1 Machine appearance description

- 1. **Operation panel:** function selection and parameters setting
- 2. **Positive output terminal:** to connect holder clamp
- 3. **Negative output terminal:** to connect earth clamp or welding torch
- 4. **Argon gas connector**
- 5. **Torch switch aviation socket**
- 6. **Trademark**
- 7. **Welding current adjusting knob; to adjust output current**
- 8. **Handle**
- 9. **Power switch:** power control switch
- 10. **Radiator fan**
- 11. **Mains input:** input cable
- 12. **Argon inlet**

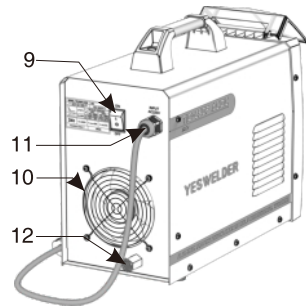
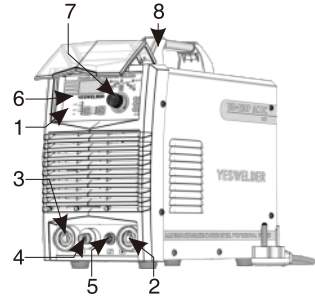

9.2 Panel description

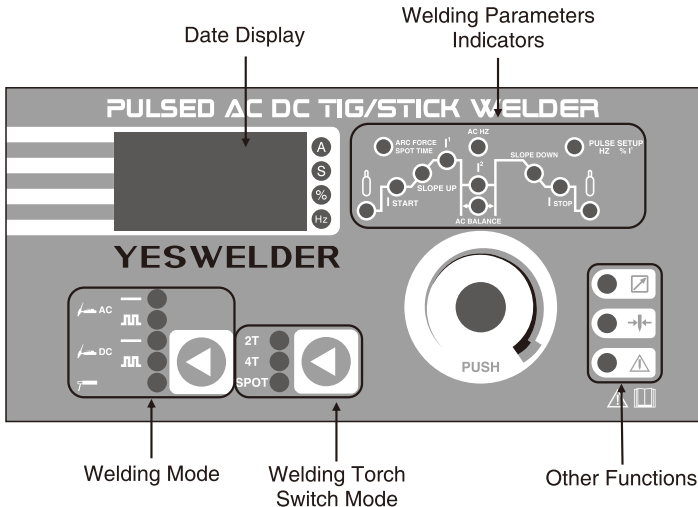

Panel Function Description



Data Display Description

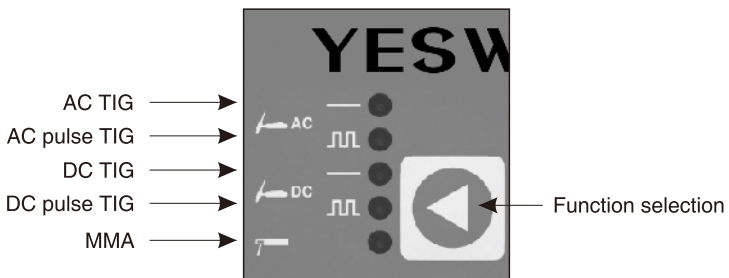

Panel Welding Mode Selection Description

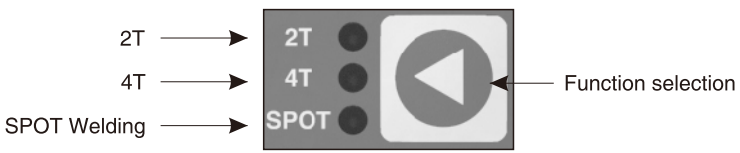

Panel Torch Switch Mode Selection Description

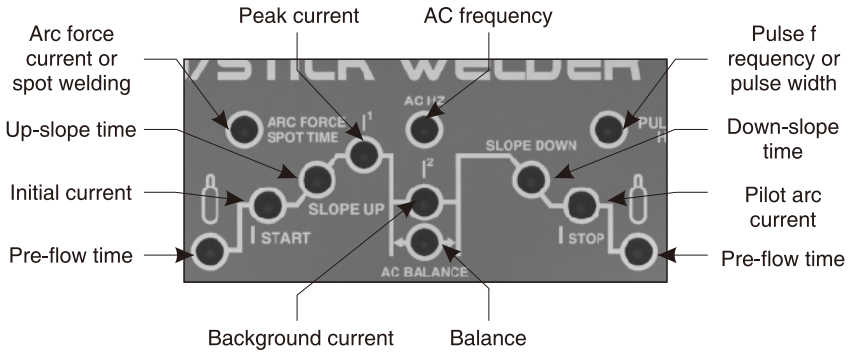

Parameters' Adjustment Selection Description

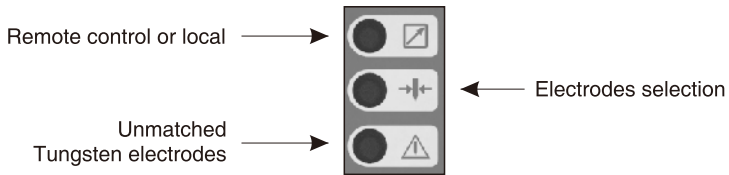

Other Function Description

9.3 Keys Operation Description

9.3.1 Welding Mode Selection

Press when no load; can choose different welding mode based on actual demands; this button is invalid in the middle of welding; mode switch will be rolling when welder is back to no load status. Please see description as below:

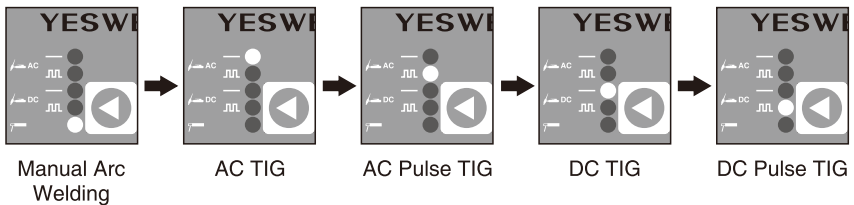

Welding Modes Selection

9.3.2 Welding Torch control mode selection

When under TIG mode or digital controlled torch mode, press  to select different torch control mode based on actual welding demands. This button is invalid in the middle of welding; mode switch will be rolling when welder is back to no load status. Please see description as below:



Welding Modes Selection 1

when under TIG mode and adjusting torch control mode or pedal remote control box, press  to select different torch control mode based on actual welding demands. This key is invalid in the middle of welding; mode switch will be rolling when welder is back to no load status. Please see description as below:





Pedal Remote Control or analog controlled torch mode

Welding Modes Selection 2

Note: this mode is on the premise that entering remote control mode through torch switch control.

9.3.3 Welding Parameters Setting

Press rotary encoder potentiometer  ^{PUSH} adjust welding parameters based on actual demands. The parameters' setting can be done during no load or in the middle of welding without affecting welding.

Welding mode	Torch switch mode	Pre-flow	Initial current	Up slope time	Peak current	Background current	AC frequency	Balance
MMA	NO	×	×	×	●	×	×	×
DC TIG	2T	●	●	●	●	×	×	×
	4T	●	●	●	●	×	×	×
	Spot welding	●	●	●	●	×	×	×
DC Pulse TIG	2T	●	●	●	●	●	×	×
	4T	●	●	●	●	●	×	×
	Spot welding	●	●	●	●	●	×	×
AC TIG	2T	●	●	●	●	×	●	●
	4T	●	●	●	●	×	●	●
	Spot welding	●	●	●	●	×	●	●
AC Pulse TIG	2T	●	●	●	●	●	●	●
	4T	●	●	●	●	●	●	●
	Spot welding	●	●	●	●	●	●	●
Adjusting direction								

Welding mode	Torch switch mode	Pulse frequency	Pulse width	Down slope time	Pilot arc current	Post-flow	Arc force current	Spot welding time	Tungsten electrodes or electrodes selection
MMA	NO	×	×	×	×	×	●	×	●
DC TIG	2T	×	×	●	●	●	×	×	●
	4T	×	×	●	●	●	×	×	●
	Spot welding	×	×	●	●	●	×	●	●
DC Pulse TIG	2T	●	●	●	●	●	×	×	●
	4T	●	●	●	●	●	×	×	●
	Spot welding	●	●	●	●	●	×	●	●

AC TIG	2T	×	×	●	●	●	×	×	●
	4T	×	×	●	●	●	×	×	●
	Spot welding	×	×	●	●	●	×	●	●
AC Pulse TIG	2T	●	●	●	●	●	×	×	●
	4T	●	●	●	●	●	×	×	●
	Spot welding	●	●	●	●	●	×	●	●
Adjusting direction									

Notes:

- means available, × means null.
- If the indicator is not in peak current and stop spinning rotary knob, it will go back to peak current position after 10 seconds.
- Electrodes selection function is for choosing a suitable welding parameter; eg. arc start current, welding current range; if the electrode chosen by operator doesn't match electrode parameters on the control panel, Δ will illuminate yellow, which means the welding performance is being affected; so only with the suitable electrode parameter and welding current, can Δ light off and to achieve the best welding performance.
- When switch welding modes, if part of parameters are the same, then there is no need to change the parameters during adjustment and these parameters will change automatically due to different mode's condition limits.

9.4 Welding Mode Description

9.4.1 MMA

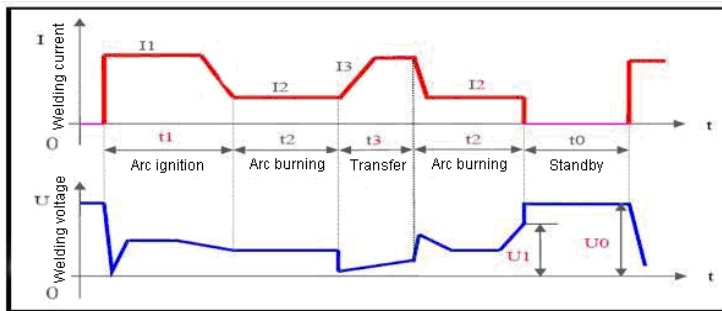

Current and Voltage Change during MMA

Note:

t0—Standby: No welding current; output voltage is the no-load voltage.

t1—Arc ignition: Welding current is arc ignition current (I1).

t2—Arc burning: Welding current is the preset current (I2).

t3—Short-circuit transfer: Welding current is the short-circuit transfer current (I3).

In SMAW mode, 4 parameters that can be adjusted directly and 1 parameter that can only be adjusted through programming are available for this machine. Describe them as below.

- **Current (I2):** This is the welding current when arc is burning, and users can set it according to their own technical requirements.
- **Arc force:** It refers to the ascending slope of the current in short circuit, and it is set as the amperage increased per millisecond in this machine. The current will ascend from the preset value by this slope after short circuit occurs. (E.g. When the preset current is 100A and the arc force is 20, the current will be 200A 5ms after short circuit occurs.) If it is still under short circuit when the current increases to the allowable maximum value 250A, the current will not ascend any more. If the short circuit status lasts for 0.8s or more, the machine will enter into electrode sticking process: to wait the disconnection of the electrode under low current. Arc force should be set according to the electrode diameter, preset current and the technical requirement. If the arc force is big, the molten drop can be transferred quickly, and electrode sticking seldom occurs. However, too big arc force may lead to excessive spatter. If the arc force is small, there will be little spatter, and the weld bead will be shaped well. However, too small arc force may lead to soft arc and electrode sticking. Therefore, the arc force should be increased when welding with thick electrode under low current. In general welding, the arc force may be set at 5~50.
- **Arc ignition current (I1) and arc ignition time (T1):** Arc ignition current is the output current of the machine when the arc is ignited. Arc ignition time is the time that the arc ignition current lasts. When in non-contact ignition mode, neither parameter makes sense. When in high current ignition mode, the arc ignition current is generally 1.5~3 times the welding current, and the arc ignition time is 0.02~0.05s. When in low current ignition mode, the arc ignition current is generally 0.2~0.5 times the welding current, and the arc ignition time is 0.02~0.1s.

Operation hints	Arc ignition modes in SMAW
<ul style="list-style-type: none">• Low current arc ignition: This can be also called lift/soft arc ignition. Set the arc ignition current (I1) to be a value lower than I2 and the machine will enter into low current arc ignition mode. Touch the workpiece with the electrode, and lift the electrode to the normal position to weld after arc is ignited.• High current arc ignition: This can be also called contact/thermal arc ignition. Set the arc ignition current (I1) to be a value not lower than I2 and the machine will enter into high current arc ignition mode. Touch the workpiece with the electrode, and normal welding can be carried out without lifting the electrode.	

• **Electrode Selection. See details in Table 9-1**

Table 9-1 MMA Process Specification Reference Table

Electrode Dia (mm)	Recommended Welding Current(A)	Recommended Welding Voltage(V)
1.6	30~60	21~23
2.0	50~90	22~24 </td
2.5	80~120	23~25
3.2	100~140	24~26
4.0	140~250	26~28

9.4.2 DC TIG welding

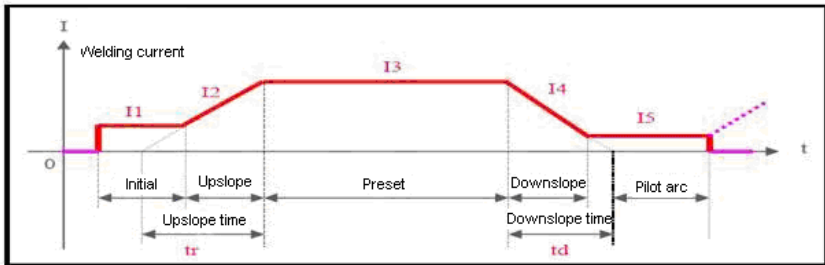

DC TIG Current Change Waveform

In DC TIG mode, 8 adjustable parameters are available for this machine. Describe them as below.

- **Current (I3):** This parameter can be set according to users' own technical requirements.
- **Initial current (I1):** It is the current when arc is ignited by pushing the torch trigger, and it should be set according to users' own technical requirements. If the initial current is high enough, arc is easier to ignite. However, it should not be too high when welding thin plate, so as to avoid burn through the workpiece during arc ignition. In some operation modes, the current does not rise but stay at the initial current value to preheat the workpiece or illuminate.
- **Pilot arc current (I5):** In some operation modes, the arc does not stop after current downslope but stay in the pilot arc state. The working current in this state is called pilot arc current, and it should be set according to users' technical requirements.
- **Pre-flow time:** It indicates the time from the torch trigger being pushed to arc being ignited in non-contact mode. Commonly it should be longer than 0.5s to make sure that the gas has been delivered to the welding torch in normal flow before arc ignition. The pre-flow time should be increased if the gas hose is long.

- **Post-flow time:** It indicates the time from the welding current being cut off to the gas valve inside the machine being closed. If it is too long, it will lead to a waste of argon gas; if it is too short, it will result in the oxidation of weld bead. When in AC TIG or for special materials, the time should be longer.
- **Upslope time (tr):** It indicates the time spent on current rising from 0 to the preset value, and it should be set according to users' technical requirements.
- **Downslope time (td):** It indicates the time spent on current dropping from the preset value to 0, and it should be set according to users' technical requirements.
- **Tungsten Electrodes Selection:** see details in Table 9-2

Table 9-2 TIG Process Specification Reference Table

Electrode Dia (mm)	Recommended Welding Current(A)
1.0	5~30
1.6	20~90
2.0	45~135
2.5	70~180
3.2	130~250

9.4.3 Pulsed TIG welding

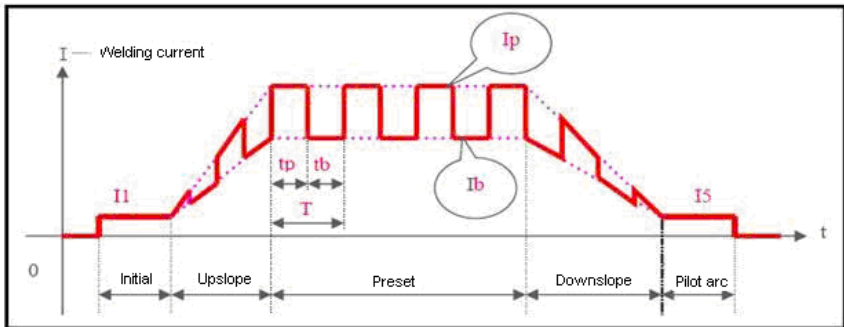

DC Pulse TIG Current Change Waveform

In pulsed TIG mode, all DC TIG parameters except current (I3) and another 4 adjustable parameters are available for this machine. Describe them as below.

- **Peak current (Ip):** It should be adjusted according to users' technical requirements.
- **Base current (Ib):** It should be adjusted according to users' technical requirements.
- **Pulse frequency (1/T):** $T = T_p + T_b$. It should be adjusted according to users' technical requirements.
- **Pulse duration ratio (100%*Tp/T):** The percentage peak current time holding in pulse period. It should be adjusted according to users' technical requirements.

9.4.4 AC square wave TIG welding

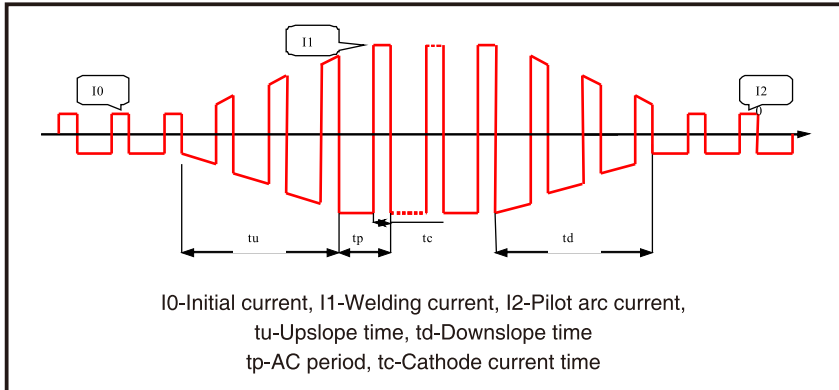

AC Square Wave TIG Current Change Waveform

In AC square wave TIG welding, the pre-flow time and post-flow time are the same with those in DC TIG welding, and others are described as below.

- **Initial current (I0), welding current (I1) & pilot arc current (I2):** The preset value of the three parameters is approximately the absolute average of the practical welding current, and can be adjusted according to user's technical requirements.
- **Pulse frequency (1/tp):** It can be adjusted according to users' technical requirements.
- **Cleaning strength (100%*Tc/Tp):** Generally, in AC welding, when taking the electrode as anode, the current is called cathode current. Its main function is to break up the oxidized layer of the workpiece, and the cleaning strength is the percentage cathode current holding in the AC period. This parameter is 10~40% commonly. When the value is smaller, arc is concentrative, molten pool is narrow and deep, and when it is bigger, arc is dispersive, molten pool is wide and shallow.

9.4.5 AC pulsed TIG welding

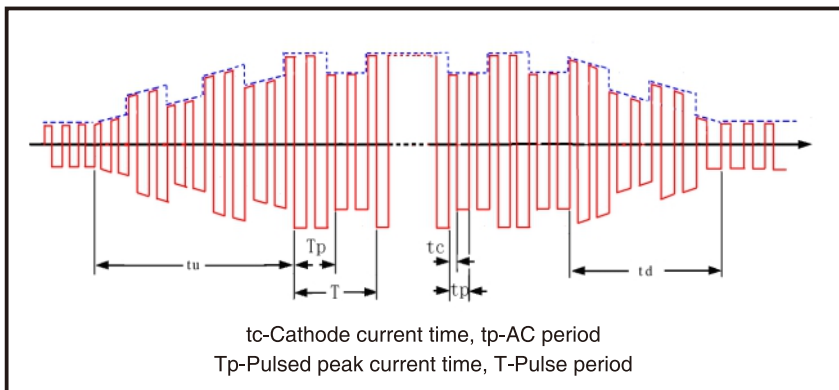

AC Pulse TIG Current Change Waveform

AC pulsed TIG welding is almost the same as AC square wave TIG welding, and what makes them different is that in AC pulsed TIG welding, the welding current varies with the pulse and peak current and base current are generated because the welding current is controlled by a low frequency pulse. The preset peak current and base current are the low frequency pulse peak value (average value) and base value (average value) respectively. For the AC square wave parameter selecting and setting, please refer to the corresponding contents in AC square wave TIG welding. For the pulse frequency and pulse duration ratio, users may refer to the corresponding contents in DC pulsed TIG welding. The pulse frequency ($1/T$) is a little low, and it can be adjusted between 0.5Hz and 5Hz. The pulse duration ratio (T_p/T) can be adjusted between 10% and 90%.

9.5 TIG operation mode

TIG operation mode is a kind of special stipulation, which stipulates the modes to control welding current through different operation of the torch trigger in TIG (DC TIG, pulsed TIG and AC TIG) welding. The introduction of TIG operation mode strengthens the application of remote control function of the torch trigger, so that users can get practical remote controls for welding machines without further investment.

TIG operation mode should be selected according to users' technical requirements and operating habits. All the TIG operation modes for this machine are listed in the table *TIG operation modes* below.

Torch trigger operation notes			
↓	Push the torch trigger.	↑	Release the torch trigger.
↓↑	Push the torch trigger and then release it at any time.	↑↓	Release the torch trigger and then push it at any time.

TIG operation modes

Mode no.	Operation	Torch trigger operation and current curve
1	<p>1T/Spot welding mode:</p> <p>① Push the torch trigger: arc is ignited and current rises to the preset value.</p> <p>② When the spot welding time is up, current drops gradually, and arc stops.</p> <p>Note: Spot welding time is 1/10 of the upslope time.</p>	

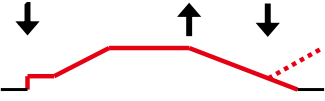
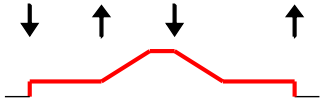
<p style="text-align: center;">2</p>	<p>Standard 2T mode:</p> <p>① Push the torch trigger: arc is ignited and current rises gradually.</p> <p>② Release the torch trigger: current drops gradually, and arc stops.</p> <p>If push the torch trigger again before arc stops, the current will gradually rise again, and then turn to ②.</p>	
<p style="text-align: center;">3</p>	<p>Standard 4T mode:</p> <p>① Push the torch trigger: arc is ignited and current reaches the initial value.</p> <p>② Release it: current rises gradually.</p> <p>③ Push it again: current drops to pilot arc current value.</p> <p>Release it: arc stops.</p>	

When reading the above table, please note:

- Whether arc ignited by HF or by striking the electrode, and no matter what kind of operation mode is selected, after arc is ignited successfully, it enters into initial current, and later into operational mode control.
- Some operation modes adopt the exit mode by pushing the torch trigger. The operator should release it after exiting welding. In this way, another welding operation can be entered by pushing the torch trigger.
- Current curves in all operation modes are drawn on the assumption that the machine works in DC TIG mode. If the machine works in pulsed TIG mode, the current curve appears a pulse shape; if the machine works in AC TIG mode, the current curve appears a variable polarity pulse shape.
- Customarily, the TIG operation modes most widely used are 2T and 4T, which exactly correspond to operation mode 2 and 4 for this machine respectively.

10. INSTALLATION & OPERATION

Notice:

Please install the machine strictly according to the following steps.

Turn off the power supply before any electric connection operation.

IP21 enclosure protection grade, and please do not operate it in rain.

10.1 Installation

- 1) Please connect the primary power line to the according voltage class. Please make sure the power line is connected to the right voltage class.
- 2) Please make sure the primary source is in fine contact with the according power line terminal or socket and prevent oxidation.
- 3) Detect the input voltage with multimeter and make sure the values are in the fluctuation range.
- 4) Please insert the electrode holder cable plug into the front panel's lower right "+" socket, and screw tightly clockwise.
- 5) Please insert the earth clamp cable plug into the front panel's lower left "-" socket and screw tightly clockwise.
- 6) Please make sure the supply is in good ground condition.

The above 4) and 5) is DC PC as shown in Fig11.1. Operators can choose DC PC method per metal material and electrodes. Generally, basic electrode adopt DC PC (with electrode being connected with positive polarity), and no special requirement for acid electrodes.

10.2 Operation

- 1) After the correct installation per above methods, please turn on the power switch("ON").While the power supply is "ON", the welder start to work normally with the indicator lighting up and fan working(fan working is determined by temperature and it may stop).
- 2) Please pay attention to the polarity while connecting. There are normally two types of wiring: NC(negative connection) and PC(positive connection). NC: welding holder connected to "-"and work piece to "+"; PC: workpiece to "-"and welding holder to "+". Please choose the proper connection according to different workpiece and processing method. Unstable arc, spatter, and electrode sticking could happen if improper wiring is selected. Please change the quick connect plug to change the polarity in case of above abnormal situation.

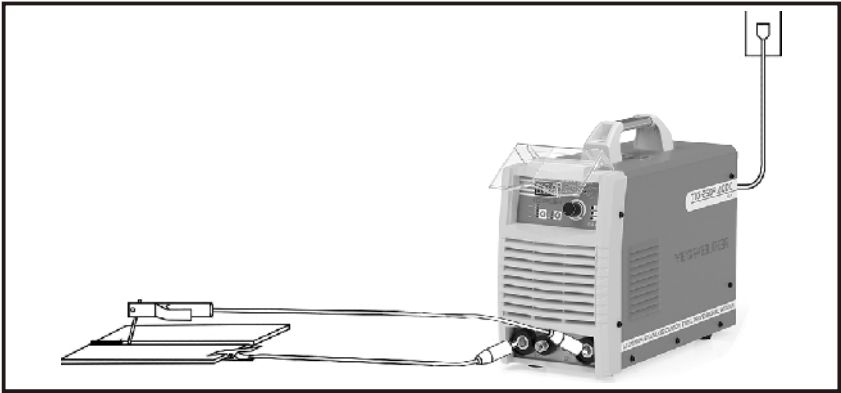

MMA Sketch Map

- 3) Please connect earth clamp to welder's "+" and torch connect to welder's "-" before TIG operation (as shown in "MMA Sketch Map"). No PC is permitted or else welding can not be processed normally. Connect torch control cable to the corresponding connector and choose the proper welding mode per workpiece material and check if the Tungsten electrode is in match with panel's Tungsten electrode parameters and current parameters. When under AC welding mode, improper balance parameter may result in abnormal welding operation.

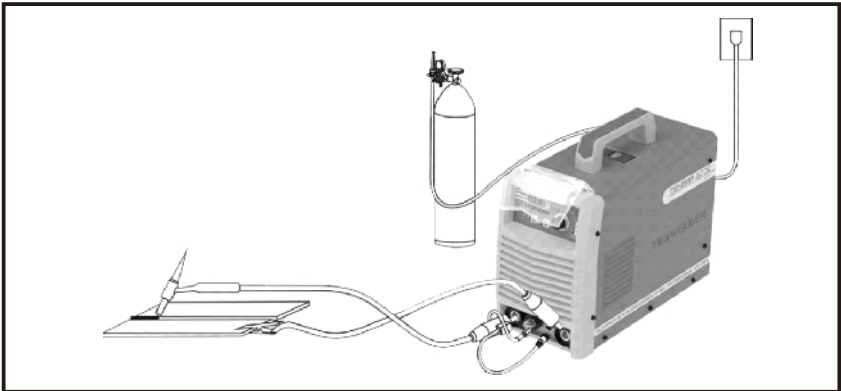

HF Arc Ignition or Lift-arc TIG Welding Sketch Map

- 4) If the distance between workpiece and welder is long and the secondary line (holder cable and ground cable) are long, please choose cables with wide cross section so that to lower cable voltage drop. Please preset current according to electrode specification, and clamp the electrode well. Welding can be started by short circuit arc ignition. Please refer to welding parameters in Table 9-2

10.3 TIG Welding Torch

Standard

Torch model: WP-26

Max current: 200A

Rated current: 160A

Cooling type: Air

Gas connector: M16×1.5

Rated duty circle: 60%

Welding torch accessory

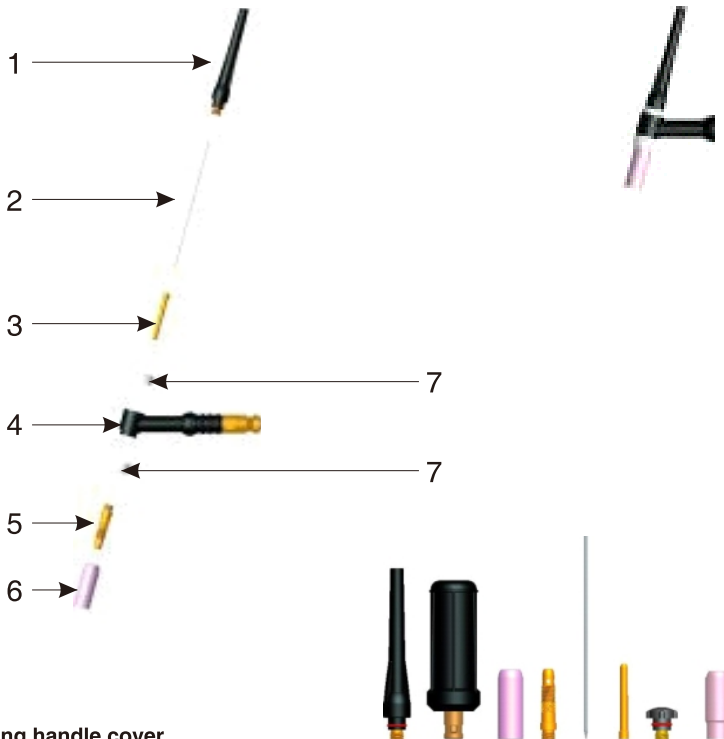

1. Long handle cover
2. Tungsten needle
3. Tungsten electrode clamp
4. Torch head
5. Tungsten electrode diffusers
6. Ceramic nozzle
7. Spearhead insulation cover

Assemble the welding torch as shown above.

11. CAUTION

11.1 Working Environment

- 1)Welding should be carried out in dry environment with humidity of 90% or less.
- 2)The working environment temperature should be between -10°C and 40°C.
- 3)Avoid welding in the open air unless sheltered from sunlight and rain. Keep welder dry .
- 4)Avoid welding in dusty area or environment with corrosive chemical gas.
- 5)Gas shielded arc welding should be operated in environment without strong airflow.

11.2 Safety Tips

Over-current/over-voltage/over-heating protection circuit is installed in this machine. When the network voltage, output current or inner temperature exceeds the setting standard, the machine will stop working automatically. However, excessive operation (over voltage) will lead to welder damage. Therefore, please note:

1) Ventilation

This is an industrial welding machine and can create large current that requires strict cooling devices instead of natural ventilation. Therefore the built-in two fans are very important to ensure effective cooling and stable working performance. The operator should make sure that the louvers be uncovered and unblocked. The minimum distance between the machine and nearby objects should be 30cm. Good ventilation is of critical importance to the normal performance and lifespan of the machine.

2) Over-load is forbidden

The welder is operated according to allowable duty circle (refer to the corresponding duty cycle). Make sure that the welding current should not exceed the max load current. Overload could obviously shorten the machine's lifespan, or even damage the machine.

3) Over-voltage is forbidden

Please refer to “Technical Parameters” for the power supply voltage range. This machine is of automatic voltage compensation to ensure the welding voltage is within the given range. In case that the input voltage exceeds the stipulated value, it would possibly damage the components of the machine. The operator should take according measures to this case.

4) Reliable ground connection.

There is an ground screw(with ground remark) in the rear part of each machine. Connect it with an earth cable (section $\geq 6\text{mm}^2$) to avoid the static and electric shock.

- 5) A sudden halt may occur with the front panel's red indicator lighting up while the machine is of over-load status. Under this circumstance, it is unnecessary to restart the machine for it's resulted from over-heating, and the temperature control switch was triggered. Keep the built-in fans working to lower the machine's temperature. Welding can be resumed when temperature falls into the standard range and the red indicator is off.

12. BASIC KNOWLEDGE OF WELDING

12.1 Basic knowledge of MMA

Manual metal arc welding (MMA) is an arc welding by manually operating electrode. MMA requires simple equipment and is a convenient, flexible and adaptive welding processing type. MMA is applied to various metal materials with thickness more than 2mm. It's suitable for various material structures, particularly to workpiece with complex structure and shape, short weld joint or bending shape, as well as weld joints in various spatial locations.

12.1.1 Welding Process of MMA

Connect the two output terminals of the welder to the workpiece and electrode holder respectively, and then clamp the electrode by the electrode holder. When welding, arc is ignited between the electrode and the workpiece, and the end of the electrode and part of the workpiece is fused to form a weld crater under the high-temperature arc. The weld crater is quickly cooled and condensed to form weld joint which can firmly integrally connect two separate pieces of workpiece. The coating of the electrode is fused to produce slag to cover the weld crater. The cooled slag can form slag crust to protect the weld joint. The slag crust is removed at last, and the joint welding is finished.

12.1.2 Tools for MMA

Common tools for MMA include electrode holder, welding mask, slag hammer, wire brush (see Fig. 12.1), welding cable and labor protection supplies.(the picture is only for reference, please make the object as the standard.)

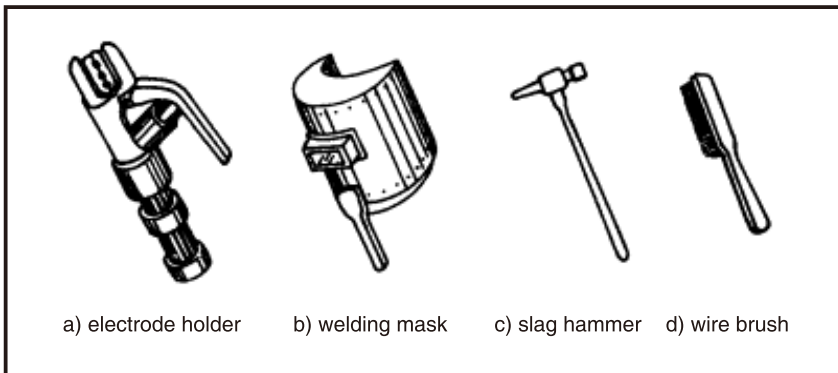

Fig 12.1 Tools for MMA

- a) Electrode holder:** a tool for clamping electrode and conducting current, mainly including 300A type and 500A type.
- b) Welding mask:** a shielding tool for protecting eyes and face from injuring due to arc and spatter, including handholding type and helmet type. Colored chemical glass is installed on the viewing window of the mask to filter ultraviolet ray and infrared ray. Arc burning condition and weld crater condition can be observed from the viewing window during welding. Thus, welding can be carried out by operators conveniently.
- c) Slag hammer (peen hammer):** for the use of removing slag crust on the surface of weld joint.

- d) **Wire brush:** for the use of removing dirt and rust at the joints of the workpiece before welding, as well as cleaning the surface of weld joint and the spatter after welding.
- e) **Welding cable:** generally cables formed from many fine copper wires. Both YHH type arc welding rubber sleeve cable and THHR type arc welding rubber sleeve extra-flexible cable can be used. Electrode holder and welding machine are connected via a cable, and this cable is named as welding cable (live wire). Welding machine and workpiece are connected via another cable (earth wire). The electrode holder is covered with insulating material performing insulation and heat insulating.

12.1.3 Basic Operation of MMA

1) Welding joint cleaning

Rust and greasy dirt at the joint should be removed completely before welding in order to implement arc igniting and arc stabilizing conveniently as well as ensure the quality of weld joint. Wire brush can be used for condition with low requirement on dust removal; grinding wheel can be used for condition with high requirement on dust removal.

2) Posture in operating

Take flat welding of butt joint and T-shaped joint from left to right as an example. (See Fig. 12.2) The operator should stand at the right side of the working direction of weld joint with mask in the left hand and electrode holder in the right hand. The left elbow of the operator should be put on his left knee to prevent his upper body from following downwards, and his arm should be separated from the costal part so as to stretch out freely.

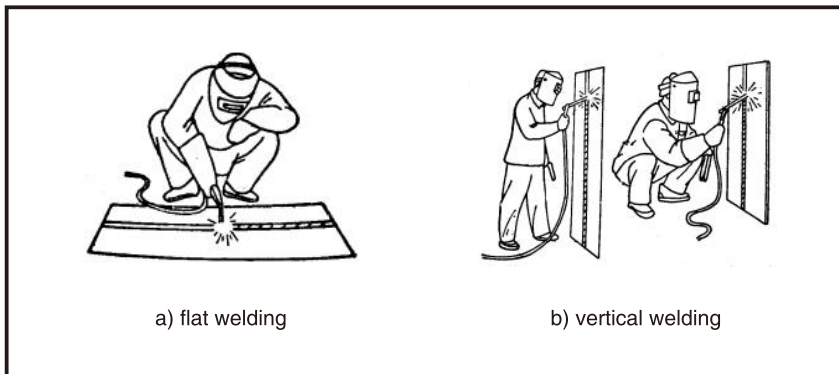

Fig 12.2 Posture in welding

3) Arc igniting

Arc igniting is the process for producing stable arc between electrode and workpiece in order to heat them to implement welding. Common arc ignition mode includes scraping mode and striking mode. (See Fig.12.3) During welding, touch the surface of the workpiece with the end of the electrode by scraping or light striking to form short circuit, and then quickly lift the electrode 2~4mm away to ignite arc. If arc ignition fails, it is probably because there is coating at the end of the electrode, which affects the electric conduction. In this case, the operator can strongly knock the electrode to remove the insulation material until the metal surface of the core wire can be seen.

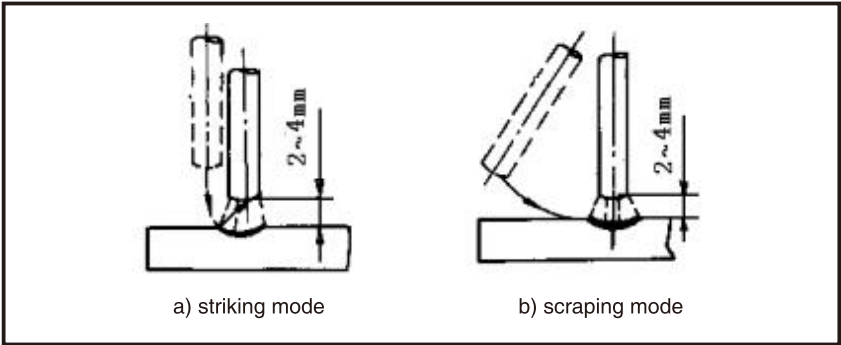

Fig 12.3 Arc igniting modes

4) Tack weld

For fixing the relative positions of the two pieces of weldment and welding conveniently, 30~40mm short weld joints are welded every certain distance in order to fix the relative positions of the workpiece during welding assembly. This process is named as tack weld.

5) Electrode manipulation

The electrode manipulation actually is a resultant movement in which the electrode simultaneously moves in three basic directions: the electrode gradually moves along the welding direction; the electrode gradually moves toward the weld crater; and the electrode transversely swings. (See Fig.12.4) Electrode should be correctly manipulated in three movement directions after arc is ignited. In butt welding and flat welding, the most important is to control the following three aspects: welding angle, arc length and welding speed.

(1)welding angle: the electrode should be inclined in $70 \sim 80^\circ$ forwards. (See Fig.12.5)

(2)Arc length: the proper arc length is equal to the diameter of electrode in general.

(3)Welding speed: proper welding speed should make the crater width of the weld bead about twice the diameter of the electrode, and the surface of the weld bead should be flat with fine ripples. If the welding speed is too high, and the weld bead is narrow and high, the ripples are rough, and the fusion is not well implemented. If the welding speed is too low, the crater width is excessive, and the workpiece is easy to be burned through. Besides, current should be proper, electrode should be aligned, arc should be low, and welding speed should not be too high and should be kept uniform during the whole welding process.

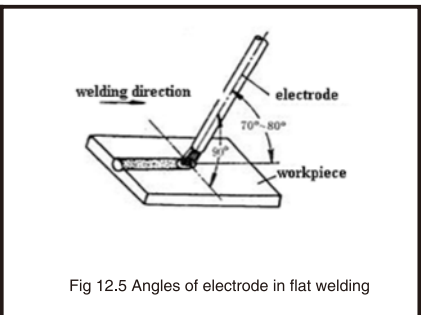
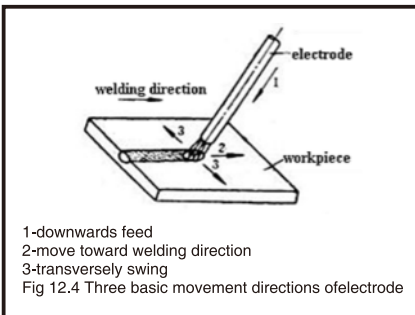

6) Arc extinguishing

Arc extinguishing is unavoidable during welding. Poor arc extinguishing may bring shallow weld crater and poor density and strength of weld metal by which cracks, air holes, slag inclusion and others shortages are easy to be produced. Gradually pull the end of the electrode from the groove and raise the arc when extinguishing arc, in order to narrow the weld crater and reduce the metal and heat. Thus, defects such as cracks and air holes can be avoided. Pile up the weld metal of the crater to make the weld crater sufficiently transferred. Then, remove the excessive part after welding. The operation modes of arc extinguishing are shown in the Fig 12.6 .

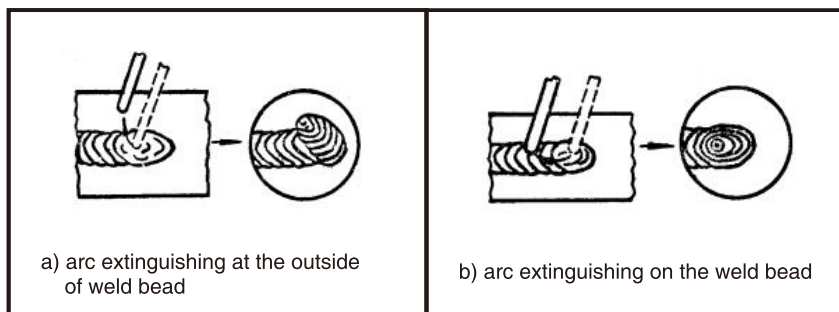

Fig 12.6 Arc extinguishing modes

7) Weldment cleaning

Clean welding slag and spatter with wire brush and similar tools after welding.

12.2 Argon arc welding

12.2.1 General description of argon arc welding

Argon arc welding is a kind of gas shielded arc welding using argon as shield gas, and the process of argon arc welding is shown in Fig. 12.7. Tightly close protective layer is formed in the arc zone by the argon gas flow output from the torch nozzle. Thus, the metal molten pool can be protected and separated from the air. Meanwhile, the filler wire and base metal is molten by the heat generated from arc. After the liquid molten pool cools down, weld bead is formed.

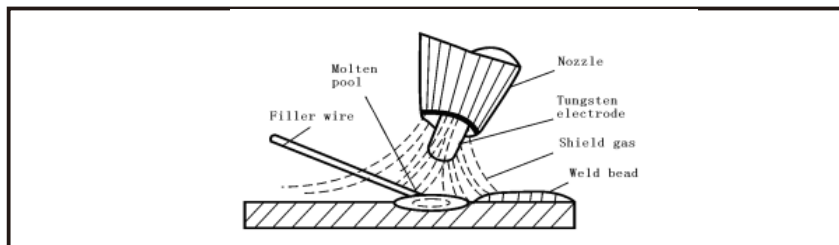

Fig 12.7 Arc extinguishing modes

Since argon is a kind of inert gas and it does not react with metals, the alloying elements in the weld metal will not be burned out and the metal molten pool can be fully protected from oxidation. Besides, because argon is insoluble in liquid metal at high temperature, air holes can be avoided in weld bead. Therefore, the protective effect of argon is effective and reliable, and better welding quality can be obtained.

12.2.2 Characteristics of argon arc welding

Compared with other arc welding methods, argon arc welding has the following features.

- 1) Argon has excellent protective performance, so corresponding flux coating is not needed when welding. It is basically a simple process of metal melting and crystallization, and pure weld bead of high quality can be obtained.
- 2) Due to the compression and cooling effect of argon flow, the heat of arc is concentrated with high temperature. Therefore, the heat affected zone is very narrow, and there is little welding deformation stress and crack tendency. Thus, argon arc welding is suitable for thin plate welding especially.
- 3) Argon arc welding is a kind of open flame welding and is easy to operate and observe, so the mechanization and automation of welding process can be achieved easily. Besides, welding at various spatial locations can be carried out under certain conditions.
- 4) Argon arc welding can be applied to welding a wide range of welding materials. Almost all metal materials can be welded by argon arc welding, and it is especially suitable for welding chemically active metals and alloys. Generally, it is used in the welding of aluminum, titanium, copper, low alloy steel, stainless steel and refractory steel, etc.

With the increasing of product structure of non-ferrous metals, high alloy steel and rare metals, common gas welding methods and arc welding methods are difficult to obtain the required welding quality. However, argon arc welding are being more and more widely used due to its remarkable characteristics above.

12.2.3 Gas tungsten arc welding (GTAW)

a)Welding torch

The function of welding torch for GTAW is to clamp the electrode, conduct current and carry argon flow. For manual welding, ON/OFF button is mounted on the handle of the welding torch. Generally, welding torches can be divided into three categories, large-type, medium-type and small-type. For small-type welding torch, the maximum welding current is 100A. And the welding current can reach up to 400~600A for large-type welding torch with water cooling. The torch body is pressed from nylon, so it is light, small-sized, insulated and heat-resistant.

The torch nozzle plays an important part in the protective performance of argon. The common nozzle shapes are shown in Fig. 12.8. Cylindrical nozzle with cone-shaped or spherical end has the best protective effect, since the argon flow speed is uniform, and laminar flow is easy to hold. The protective effect of the coniform nozzle is worse, because the argon flow speeds up. However, this kind of nozzle is easy to operate and the visibility of the molten pool is good, so it is also commonly used in welding.

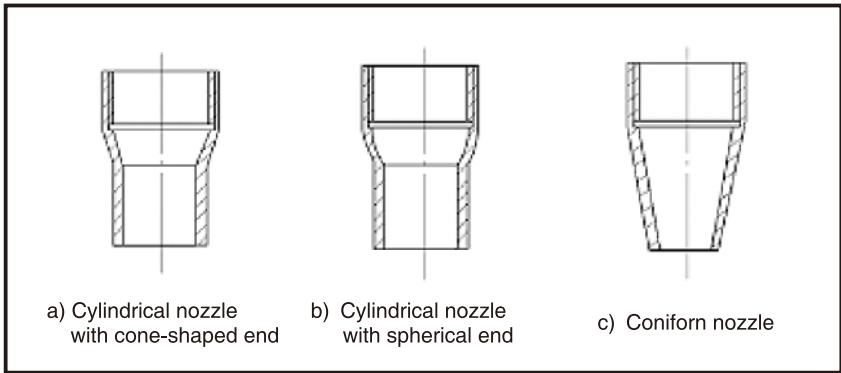

Fig. 12.8 Sketch map of nozzle shape

12.2.4 GTAW process

① Preweld cleaning

Clean the electrode and the zone near the weld joint of the workpiece, and remove impurities such as oil pollution and the oxidized film on the surface of the metal before carrying out argon arc welding to ensure good quality of weld bead. The methods for preweld cleaning are: mechanical cleaning, chemical cleaning and chemical & mechanical cleaning.

A. Mechanical cleaning: This method is simple with good effect, and it is suitable for large-sized workpiece. Generally, remove the oxidized film by grinding with a small-diameter stainless steel wire brush or by shoveling with a scraper to make the welding position appearing with metal luster, and then clean the weld joint zone with organic solvent for eliminating oil pollution.

B. Chemical cleaning: Chemical cleaning is commonly used for cleaning the filling electrode and small-sized workpiece. Compared with mechanical cleaning, this method has such characteristics as high cleaning efficiency, uniform and stable quality and long duration of clean state. The chemical solutions and processes used in chemical cleaning should be chosen according to the welding materials and welding requirements.

C. Chemical & mechanical cleaning: Use chemical cleaning method when cleaning firstly, and clean the welding position with mechanical cleaning method before welding. This combined cleaning method is suitable for the high quality welding.

② Protective effect of gas

Argon is ideal protective gas. The boiling point of argon is -186°C , which is between that of helium and oxygen. Argon is a byproduct when the oxygen installation gets oxygen by fractionating the liquid air. Bottled argon is used for welding in our country. The filling pressure is 15MPa under room temperature, and the cylinder is painted gray and marked with "Ar". The chemical composition requirements of pure argon are: $\text{Ar} \geq 99.99\%$; $\text{He} \leq 0.01\%$; $\text{O}_2 \leq 0.0015\%$; $\text{H}_2 \leq 0.0005\%$; $\text{C} \leq 0.001\%$; $\text{H}_2\text{O} \leq 30\text{mg/m}^3$.

Welding arc can be better protected and the consumption of shield gas can be reduced in flat position welding. As inert gas, argon does not react with metal chemically even under high temperature. Thus, the alloying elements will not be oxidized or burned out, and problems caused accordingly will be avoided. Meanwhile, argon is insoluble in liquid metal, so air holes can be avoided. Argon is a kind of monatomic gas, existing in atomic state, without molecular decomposition and atomic endotherm under high temperature. Besides, the specific heat capacity and heat conductivity is low, so the arc heat is not easy to lose. Accordingly, the welding arc can burn stably and heat can be concentrated, which is advantageous to welding.

The disadvantage of argon is that its ionization potential is high. When the arc space is fully filled with argon, arc is hard to ignite. However, arc will become stable once it is successfully ignited.

The gas protective effect of argon can be affected by various process factors during welding. Therefore, special attention should be paid to the effective protection of argon in GTAW to avoid interference and damage. Otherwise, satisfactory welding quality is hard to obtain.

Welding process factors such as gas flow, shape and diameter of nozzle, distance between nozzle and workpiece, welding speed and weld joint form may affect the gas protective effect, so all these should be fully considered and chosen correctly.

The gas protective effect can be judged by welding spot testing method through measuring the size of the effective gas protective area. For example, keep all welding process factors fixed when carrying out spot welding on aluminum plate with AC manual TIG, maintain the torch in the fixed position after arc is ignited, and cut off the power after the 5~10s, there will be a molten welding spot left on the aluminum plate. Due to the cathode cleaning action against the area around the welding spot, the oxidized film on the surface of the aluminum plate is eliminated, and a gray area with metallic luster appears. As shown in Fig. 12.9, this area is called effective argon protective area. The greater the diameter of the effective gas protective area, the better is the gas protective effect.

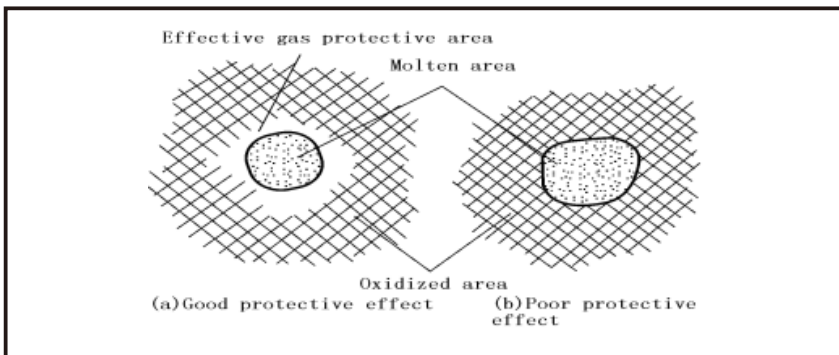

Fig. 12.9 Effective protective area of argon

In addition, the gas protective effect can be judged by directly observing the color of the weld bead surface. Take stainless steel welding for example. If the weld bead surface appears silvery white or golden, it indicates that the gas protective effect is good. However, if the weld bead surface appears gray or black, it indicates that the gas protective effect is poor.

12.2.5 Welding process parameters

The gas protective effect, welding stability and weld bead quality of GTAW has direct relationship with the welding process parameters. Therefore, select appropriate welding process parameters to ensure high quality weld joint.

The welding process parameters for GTAW include type and polarity of current, diameter of tungsten electrode, welding current, argon gas flow, welding speed and process factors, etc.

- A. The type and polarity of current for GTAW should be chosen according to the workpiece material and also the operation mode.
- B. Select tungsten electrode with proper diameter mainly according to the thickness of workpiece. Besides, when the thickness of workpiece is the same, tungsten electrodes with different diameters should be chosen due to the different current types and polarities and different allowable current ranges for the tungsten electrode. Improper tungsten diameter will lead to unstable arc, serious burn and tungsten in weld bead.
- C. Select proper welding current after the tungsten diameter is determined. Overly high or overly low welding current will cause poor weld bead or welding defects. For the allowable current ranges for thorium-tungsten/cerium tungsten electrodes with different diameters, please refer to the table below (Table 12-1).

Table 12-1 Allowable current ranges for tungsten electrodes with different diameters

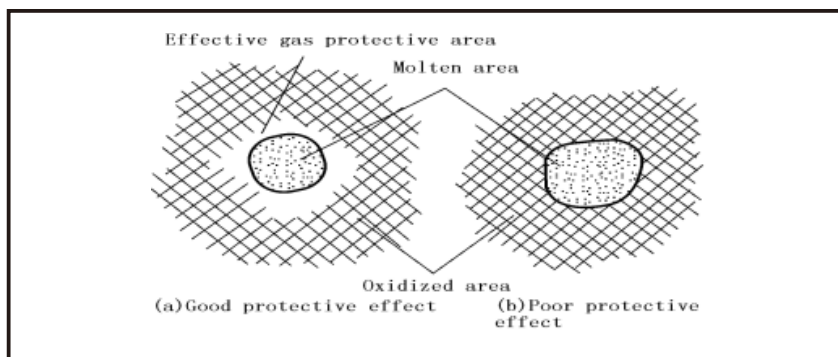

Tungsten dia. (mm)	DCEN (A)	DCEP (A)	AC (A)
1.0	15~80	—	20~60
1.6	70~150	10~20	60~120
2.4	150~250	15~30	100~180

3.2	250~400	25~40	160~250
4.0	400~500	40~55	200~320

- D.** The argon gas flow is selected mainly according to the tungsten diameter and nozzle diameter. For a nozzle with a certain aperture, the argon gas flow should be appropriate. If the gas flow is too high, the gas flow speed will increase. Thus, it is difficult to maintain stable laminar flow, and the welding zone can not be well protected. Meanwhile, more arc heat will be taken away, which will affect the arc stability. If the gas flow is too low, the gas protective effect will be affected due to the interference of the environmental airflow. Generally, the argon gas flow should be within 3~20L/min.
- E.** Under the condition of fixed tungsten diameter, welding current and argon gas flow, overly high welding speed will make the protective gas flow deviate from the tungsten electrode and molten pool, and the gas protective effect will be affected accordingly. Besides, the welding speed affects the weld bead shape significantly. Therefore, it is very important to select appropriate welding speed.
- F.** Process factors mainly refer to the shape and diameter of nozzle, the distance between nozzle and workpiece, stick-out and the diameter of filling wire, etc. Although the change of these factors is not big, it takes more or less influence on the welding process and gas protective effect. Therefore, all factors should be selected according to specific welding requirements.

Generally, the nozzle diameter should be within 5~20mm, the distance between the nozzle and workpiece should not be greater than 15mm, the stick-out should be 3~4mm, and the filling wire diameter should be selected according to the thickness of workpiece.

12.2.6 General requirements for argon arc welding

- 1) The control of gas: Pre-flow and post-flow are required in argon arc welding. Argon is a kind of inert gas that can be broken down easily. Fill the space between workpiece and tungsten electrode with argon firstly, and then arc can be easier to ignite. Keep the gas flow after welding ends, and the workpiece will not cool down too quickly. Thus, the oxidation of workpiece can be avoided, and good welding effect can be ensured.
- 2) The manual switch control of current: When the manual switch is switched on, the current supply should be delayed for the pre-flow time. After the manual switch is switched off and welding ends, the current supply should be cut off first and the gas flow maintains according to the post-flow time.
- 3) The generation and control of high voltage: The argon arc welding machine adopts high voltage arc ignition mode. It is required that there should be high voltage when igniting arc and there should be no high voltage after arc is successfully ignited.
- 4) Protection from interference: The high voltage for arc ignition in argon arc welding is accompanied with high frequency, which produces serious interference to the machine circuit. Thus, good anti-interference ability is required for the circuit.

13. OPTIONAL ACCESS OPERATION DESCRIPTION

13.1 Pedal Remoter Operation

Pedal remoter control internal structure is composed by inching switch and sliding potentiometer, as shown in below Fig 13.1.

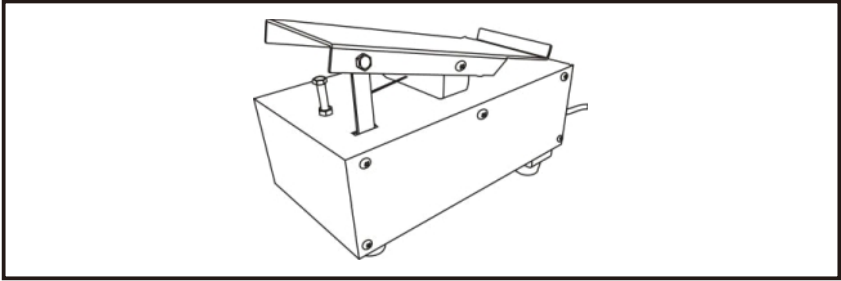

Fig 13.1 Pedal Remote Controller

Pedal controlling function is mainly used while it's under TIG mode.

- Connect the pedal remoter to the welder front panel pedal controller interface through dedicated cable. See Fig 13.2

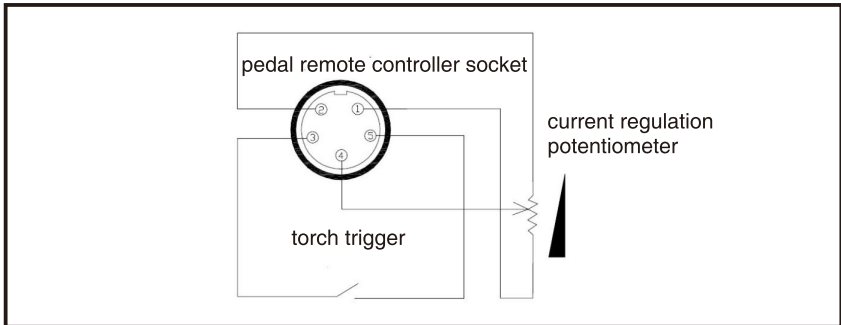



Fig 13.2

- Tread the pedal for 5 seconds while under idle load mode; the front panel remote control indicator will light up after 3 beeps. Release the pedal and enter the pedal remote control mode.
- The torch switch mode  needs being set to 2T when using the pedal remote control function. Preset the max welding current through the front panel and start welding.
- Tread the pedal control and start arc ignition. Non-contact arc ignition is the most applied method. Welding current will be controlled by pedal remoter after successful arc ignition. Max output current is the preset current.

Note: The pedal remote controller is optional. Please clarify your needs before placing orders.

13.2 Wire-drive Welding Torch Operation

There are digital control type and analog control type. See Fig 13.3

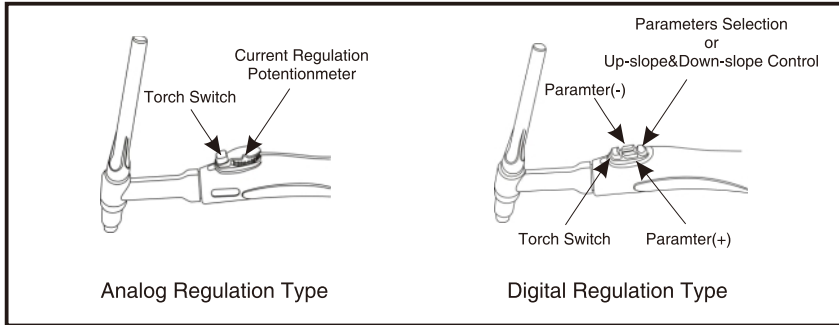

Fig 13.3

Wire-drive welding torch is usually applied while it's under TIG.

- Connect the wire-drive torch to the welder front panel pedal controller connection aviation socket through dedicated cable. See Fig below:

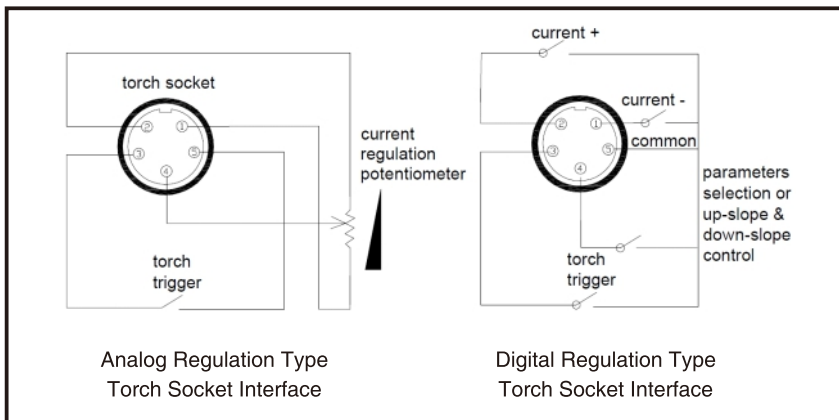

Fig 13.4

- Push the torch switch for 5 seconds while under idle load mode; the front panel remote control indicator will light up after 3 beeps and enter the remote control mode.
- The torch switch mode needs being set to 4T when using analog regulation torch function. Preset the max welding current through front panel and start welding. The welding current can be adjusted through torch potentionmeter (sic). The allowable max current is the preset peak current value.

- The functions can be divided into 2 parts when using the digital regulation torch: 1) when it's under no load mode, can set welding parameters through "Parameters Selection or Up-slope &Down-slope" bottom on the torch. "Parameters +" and "Parameters -" can set the value. 2) Torch switch only controls ON/OFF. In the middle of welding, "Parameters Selection or Up-slope & Down-slope" can only regulate welding current. "Parameters +" and "Parameters -" can set the value.

Note.

1. **Wire-drive torch is optional. Please clarify your demands before placing orders.**
2. **Welders with digital regulation torch or standard torch can't have pedal remote controller box; welders with analog regulation torch can have pedal control box.**

14. MAINTENANCE

WARNING



The following operation requires professional knowledge on electric application and comprehensive safety knowledge. Operators should be licensed with related qualification certificates (still in validation) which can prove their skills and knowledge. Make sure the power supply is cut off before uncovering the welding machine.

- 1) Check periodically whether inner circuit connection is in good condition (esp. plugs). Tighten the loose connection. If there is oxidization, remove it with sandpaper and then reconnect.
- 2) Keep hands, hair and tools away from the moving parts such as the fan to avoid personal injury or machine damage.
- 3) Clean the dust periodically with dry and clean compressed air. If welding environment with heavy smoke and pollution, the machine should be cleaned daily. The pressure of compressed air should be at a proper level in order to avoid the small parts inside the machine being damaged.
- 4) Avoid rain, water and vapor infiltrating the machine. If there is, dry it and check the insulation of the equipment (including that between the connections and that between the connection and the enclosure). Only when there are no abnormal phenomena anymore, can the machine be used.
- 5) Check periodically whether the insulation cover of all cables is in good condition. If there is any dilapidation, rewrap it or replace it.
- 6) Put the machine into the original packing in dry location if it is not to be used for a long time.

15. TROUBLESHOOTING

WARNING



The following operation requires professional knowledge on electric application and comprehensive safety knowledge. Operators should be licensed with related qualification certificates (still in validation) which can prove their skills and knowledge. Make sure the power supply is cut off before uncovering the welding machine.

15.1 Common Malfunction Analysis and Solution

The failures listed below may be related to your accessories, gas, working environment, power supply conditions. Please try to improve the above so that to avoid similar failures.

Table 15-1 MMA common malfunction solutions

Malfunction phenomena		Cause analysis	Solutions
Fan doesn't work or has abnormal revolving speed after power on		Temperature is too low or fan is broken.	When the temperature is too low, please operate welder for a while and wait till the internal temperature is increased; if the fan is still not working, change the fan.
M M A	Difficult arc ignition	Low arc ignition current or short ignition time.	Adjust (increase) the arc ignition current and time.
	Over arc ignition or over-size molten pool	Ignition current is too big or ignition time is too long.	Adjust (decrease) the arc ignition current and time.
	Abnormal arc	Poor power cable connection	Make sure the well connection of power cable.
	Sticking electrode	Low arc force current	Adjust(increase) the arc force current
	Burning electrode holder	Electrode holder rated current is too low	Change a larger current electrode holder.
	Easy arc breaking	Network voltage is too low	Please operate when network voltage is back to normal.

Table 15-2 TIG common malfunction solutions

Malfunction phenomena		Cause analysis	Solutions
Fan doesn't work or has abnormal revolving speed after power on		Temperature is too low or fan is broken.	When the temperature is too low, please operate welder for a while and wait till the internal temperature is increased; if the fan is still not working, change the fan.
T I G	No output current when torch switch is on.	Some TIG function allows welding ending while torch switch is still on.	Release torch switch and restart welding.
		Welding circuit disconnection	Check the circuit and reconnect
	When it's under HF arc ignition mode, no arc ignition when turn on the torch switch.	Poor connection of welding torch switch.	Reconnect and tighten the welding torch
		Over-wide spark gap.	Adjust the spark gap (about 0.8mm)
	Over burning of tungsten electrode.	Reverse connection of welding torch and ground cable	Exchange the two plugs' position
		Clearing intensity is too big	Decrease the clearing intensity
Burning electrode holder	Electrode holder rated current is too low	<ol style="list-style-type: none"> 1. Make sure the argon cylinder valve is open and has enough pressure. If the internal pressure is lower than 0.5Mpa, please refill the gas. 2. Please check if the argon flow is normal or not. You may choose different flow according to different welding current. But under-volume gas flow may result in incomplete coverage of welding spot. We suggest the min argon flow of 5L/min no matter how small the welding current is. 3. Please make sure the well sealing of all gas circuit as well as gas purity. 4. Please check if there is strong air-flow in the working environment. 	

	Difficult arc ignition, easy arc breaking	Poor quality tungsten electrode or severe oxidation of tungsten electrodes	<ol style="list-style-type: none"> 1.Change good quality tungsten electrodes 2.Remove the oxidation layer. 3.Prolong the post-flow time so that to avoid tungsten oxidation 4.Adjust the spark gap (around 0.8mm)
	Unstable welding current during welding	Big fluctuation of network voltage or poor connection with power grid. Interference from other equipment	<ol style="list-style-type: none"> 1.Make sure the power grid is normal and well connection of power source connector. 2.Use different power cables for those severe interference equipments

Please fix the welding failures timely. Only qualified personnel can fix welders; Disassemble or overhaul welders by disqualified personnel is prohibited, as it could cause serious danger or bigger damages to other critical components.

This product is under continuous improvements; therefore, there might be differences in some respects except for functions and operation. Your understanding is much appreciated.

15.2 Alarm and Solutions (Table 15-3)

Table 15-3 Alarm and Solutions

Type	Alarm	Error code	Welder reaction	Reason	Solutions
Over-heat	Overheat indicator lights up and there is alarm sound	E - 1	Temporary close of main circuit	Over-working of main circuit	Do not power off; restart welding when the over-heat indicator stop lighting up.

Under-voltage	Display error code and there is alarm sound	E - 2	Permanently close main circuit and need to restart the machine	Power grid under-voltage(lower than 160VAC)	Please shut off the welder and restart. If there is a continuous power grid undervoltage, please wait and restart welder when the power grid is back to normal. If power grid voltage is normal but with undervoltage warning, please contact professional maintenance personnel.
Abnormal internal circuit	Display error code and there is alarm sound	E - 4	Permanently close main circuit	Load current is too big or main power device is under over-current protection.	Please restart welder. If the warning still remains, please contact professional maintenance personnel.

APPENDIX A: TRANSPORTATION AND STORAGE

A1. Transportation

Equipment should be handled with care in transportation to avoid severe impact. Equipment should be prevented from being affected with damp and caught in the rain in transportation.

A2. Storage

Temperature for storage: -25°C~+50°C

Humidity for storage: relative humidity ≤90%

Storage life: 12 months

Place for storage: ventilated indoor place without corrosive gas

APPENDIX B: WIRING DIAGRAM OF COMPLETE MACHINE

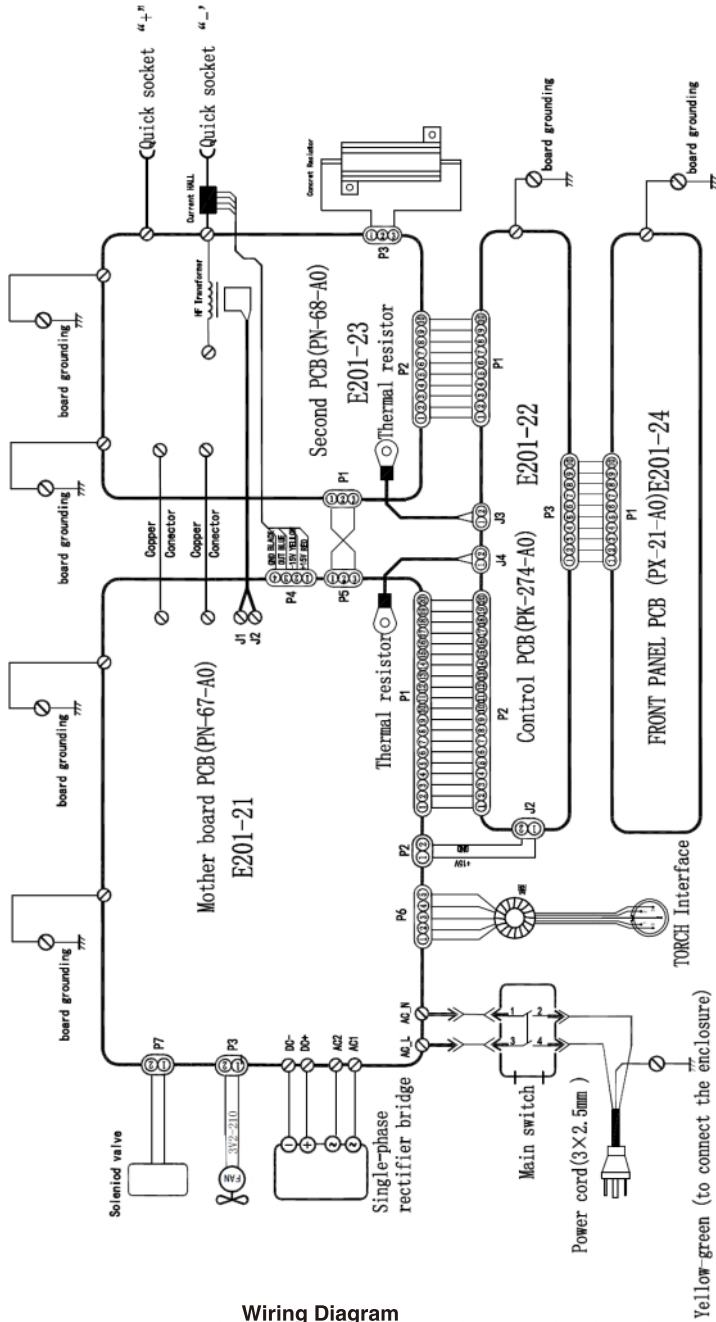

Wiring Diagram

Copyright © Yeswelder