

# LYG-19800GK SERIES

## AUTO-DARKENING WELDING HELMETS

Dec., 2022

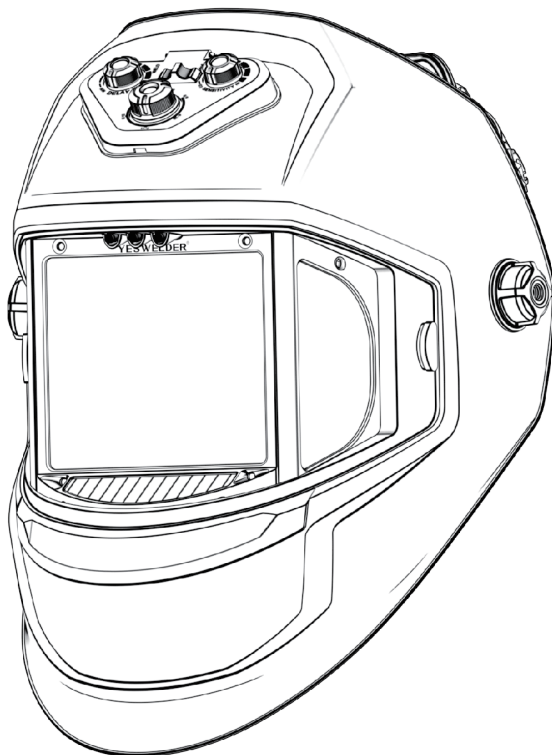

OPERATOR'S MANUAL

**YESWELDER**®

Copyright © YesWelder

 To help us serve you better, go to [www.YesWelder.com](http://www.YesWelder.com)



# TABLE OF CONTENTS

---

<b>SECTION 1 – WELDING HELMET SAFETY PRECAUTIONS –READ BEFORE USING . . . .</b>	<b>01</b>
1-1. Symbol Usage . . . . .	01
1-2. Arc Welding Hazards . . . . .	01
1-3. Proposition 65 Warnings . . . . .	02
<b>SECTION 2 – SPECIFICATIONS . . . . .</b>	<b>03</b>
<b>SECTION 3 – OPERATING INSTRUCTIONS . . . . .</b>	<b>04</b>
3-1. Helmet Controls . . . . .	04
3-2. Reset Button And Low Battery Indicator . . . . .	05
3-3. Lens Delay Control . . . . .	05
3-4. Variable Shade Control . . . . .	06
3-5. Shade Selection Chart . . . . .	07
3-6. Sensitivity Control . . . . .	08
3-7. LED Control Function . . . . .	09
<b>SECTION 4 – ADJUSTING HEADGEAR . . . . .</b>	<b>10</b>
<b>SECTION 5 – REPLACING THE LENS COVERS . . . . .</b>	<b>11</b>
<b>SECTION 6 – CHARGE . . . . .</b>	<b>12</b>
<b>SECTION 7 – MAINTENANCE . . . . .</b>	<b>13</b>
<b>SECTION 8 – TROUBLESHOOTING GUIDE . . . . .</b>	<b>14</b>
<b>SECTION 9 – HEADBAND INSTALLATION . . . . .</b>	<b>15</b>
<b>SECTION 10 – LIMITED WARRANTY . . . . .</b>	<b>16</b>

# SECTION 1 - WELDING HELMET SAFETY PRECAUTIONS - READ BEFORE USING

 **Protect yourself and others from injury - read and follow these precautions.**

## 1-1. Symbol Usage

 **DANGER!** – Indicates a hazardous situation which, if not avoided, will result in death or serious injury. The possible hazards are shown in the adjoining symbols or explained in the text.

 Indicates special instructions.



 Indicates a hazardous situation which, if not avoided, could result in death or serious injury. The possible hazards are shown in the adjoining symbols or explained in the text.

This group of symbols means Warning! Watch Out! ELECTRIC SHOCK, MOVING PARTS, and HOT PARTS hazards. Consult symbols and related instructions below for necessary actions to avoid the hazards.

**NOTICE** – Indicates statements not related to personal injury.

## 1-2. Arc Welding Hazards

 **Only qualified persons should install, operate, maintain, and repair this unit.**



### **ARC RAYS can burn eyes and skin.**

Arc rays from the welding process produce intense visible and invisible (ultraviolet and infrared) rays that can burn eyes and skin. Sparks fly off from the weld.

- Wear a welding helmet fitted with a proper shade of filter to protect your face and eyes when welding or watching (see ANSI Z49.1 and Z87.1 listed in Safety Standards). Refer to Shade and Sensitivity charts.
- Wear approved safety glasses with side shields under your helmet.
- Use protective screens or barriers to protect others from flash, glare, and sparks; warn others not to watch the arc.
- Wear protective clothing made from durable, flame-resistant material (leather, heavy cotton, and wool) and foot protection.
- Before welding, adjust the auto-darkening lens sensitivity setting to meet the application.
- Stop welding immediately if the auto-darkening lens does not darken when the arc is struck. See the Owner's Manual for more information.



### **WELDING HELMETS do not provide unlimited eye, ear and face protection.**

Arc rays from the welding process produce intense visible and invisible (ultraviolet and infrared) rays that can burn eyes and skin. Sparks fly off from the weld.

- Use impact resistant safety spectacles or goggles and ear protection at all times when using this welding helmet.
- Do not use this helmet while working with or around explosives or corrosive liquids.
- Do not weld in the overhead position while using this helmet.
- Inspect the auto-lens frequently. Immediately replace any scratched, cracked, or pitted cover lenses or auto-lenses.



## **NOISE can damage hearing.**

Noise from some processes or equipment can damage hearing.

- Wear approved ear protection if noise level is high.

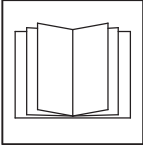

## **READ INSTRUCTIONS.**

- Read and follow all labels and the Owner's Manual carefully before installing, operating, or servicing unit. Read the safety information at the beginning of the manual and in each section.

- Use only genuine replacement parts from the manufacturer.
- Perform maintenance and service according to the Owner's Manuals, industry standards, and national, state, and local codes.



## **FUMES AND GASES can be hazardous.**

Welding produces fumes and gases. Breathing these fumes and gases can be hazardous to your health.

- Keep your head out of the fumes. Do not breathe the fumes.
- If inside, ventilate the area and/or use local forced ventilation at the arc to remove welding fumes and gases.
- If ventilation is poor, wear an approved air-supplied respirator.
- Read and understand the Material Safety Data Sheets (MSDSs) and the manufacturer's instructions for metals, consumables, coatings, cleaners, and degreasers.
- Work in a confined space only if it is well ventilated, or while wearing an air-supplied respirator. Always have a trained watchperson nearby. Welding fumes and gases can displace air and lower the oxygen level causing injury or death. Be sure the breathing air is safe.
- Do not weld in locations near degreasing, cleaning, or spraying operations. The heat and rays of the arc can react with vapors to form highly toxic and irritating gases.
- Do not weld on coated metals, such as galvanized, lead, or cadmium plated steel, unless the coating is removed from the weld area, the area is well ventilated, and while wearing an air-supplied respirator. The coatings and any metals containing these elements can give off toxic fumes if welded.

## **1-3. Proposition 65 Warnings**

**⚠** Welding or cutting equipment produces fumes or gases which contain chemicals known to the State of California to cause birth defects and, in some cases, cancer. (California Health & Safety Code Section 25249.5 et seq.)

**⚠** This product contains chemicals, including lead, known to the state of California to cause cancer, birth defects, or other reproductive harm. *Wash hands after use.*

## SECTION 2 - SPECIFICATIONS

Main Viewing Field	109.5x97mm / 4.31x3.82 inch
Side Viewing Field	95x12mm / 3.74x0.47 inch
Reaction Time	1/30000 sec (0.00003 sec)
Available Shades All Shades Provide Continuous UV And IR Protection.	<p><b>Weld Mode</b> Darkened State: DIN9-DIN13 Light State: DIN4</p> <p><b>Cut Mode</b> Darkened State: DIN5-DIN9 Light State: DIN4</p> <p><b>Grind Mode</b> Light State: DIN4</p> <p><b>UV And IR Protection</b> DIN13</p>
Sensitivity/Grind Mode Control	Adjusts for varying ambient light and welding arc
Delay Control	Slows lens dark-to-light state between 0.1 and 0.8 seconds
Charging	Use TYPE-C charging cable for charging
Low Battery Indicator	Red LED light illuminates to indicate 2~3 days remaining battery life
Power Supply	Battery&Solar supply
Sensors	Independent/Redundant (Four)
Operating Temperature	23°F to 131°F / -5°C to +55°C ☞ When stored in extremely cold temperatures, warm helmet to ambient temperature before welding.
Storage Temperature	-4°F to 158°F / -20°C to +70°C ☞ When stored in extremely cold temperatures, warm helmet to ambient temperature before welding.
Storage	Keep out of light when not in use
Standards	ANSI ISEA Z87.1-2015 and CSA
Warranty	1 year from date of purchase

# SECTION 3 - OPERATING INSTRUCTIONS

## 3-1. Helmet Controls



- 1 Reset Button (See Section 3-2)
- 2 Low Battery Indicator (See Section 3-2)
- 3 Variable Shade Control (See Section 3-4)
- 4 Sensitivity Control (See Section 3-5)
- 5 Lens Delay Control (See Section 3-3)
- 6 Mode Control Switch
- 7 LED Lamp Control Button

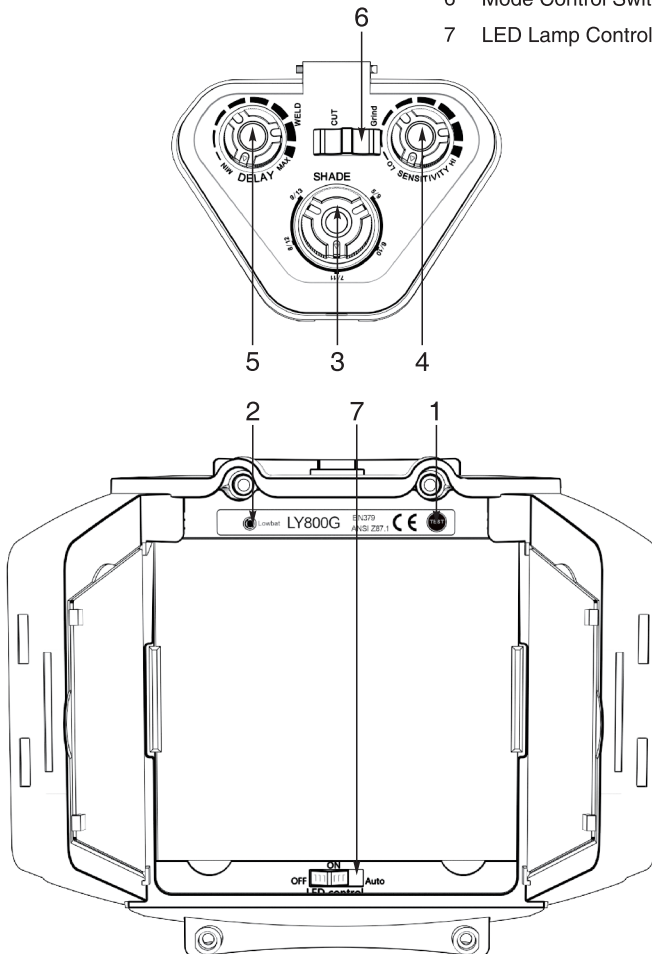

### 3-2. Reset Button And Low Battery Indicator

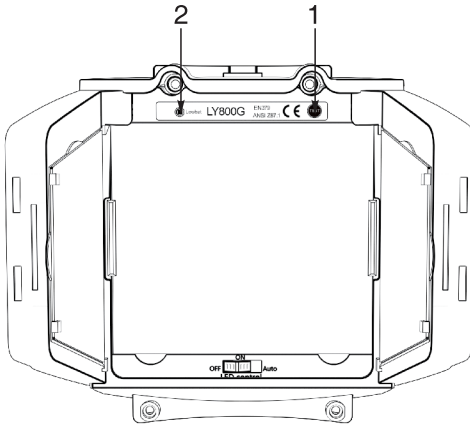

The auto-darkening lens turns on (darkens) automatically when welding begins and turns off 15 – 20 minutes after welding stops.

#### 1 Reset Button

Press Reset button to check if the lens is working properly.

When the Reset button is pressed, the lens should darken and re-to the clear state. Do not use the helmet if the lens does not function as described. (See Section 9, Troubleshooting.)

#### 2 Low Battery Indicator

The low battery indicator lights when 2–3 days of battery life remain.

If the battery power is low, connect to charge.

### 3-3. Lens Delay Control

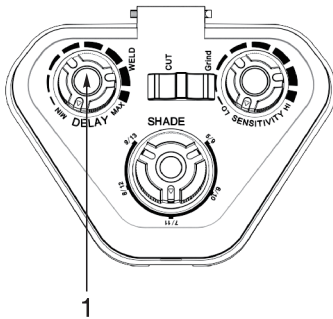

#### 1 Lens Delay Control

The lens delay control is used to adjust the time for the lens to switch to the clear state after welding.

The delay is particularly useful in eliminating bright after-rays present in higher amperage applications where the molten puddle remains bright momentarily after welding. Lens delay adjusts from min (0.10 second) to max (0.8 second).



### 3-4. Variable Shade Control

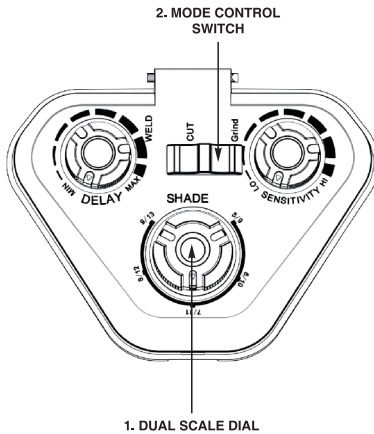

#### 1 Variable Shade Control (DIN5-9/9-13)

The shade can be adjusted from shade 5-9 or 9-13 based upon welding process or application (refer to shade selection chart on page 7). Shade is adjusted by setting the **2. MODE CONTROL SWITCH** to the proper range, then use the shade dual scale dial to set the desired shade. The mode control switch and dual scale dial are shown left.

#### 1. Weld Mode

Used for most welding applications. In this mode the lens turns on when it optically senses a welding arc. Adjust shade, sensitivity, and delay settings as needed.

#### 2. Cut Mode

Used for cutting applications. In this mode the lens turns on when it optically senses a cutting arc. Adjust shade, sensitivity, and delay settings as needed.

#### 3. Grind Mode

Used for metal grinding applications. In this mode the lens is fixed at shade No. 4. No lens adjustments are possible.

### 3-5. Shade Selection Chart



Process	Electrode Size in.(mm)	Arc Current in Amperes	Minimum Protective Shade No.	Suggested Shade No. (Comfort)*
Shielded Metal Arc Welding(SMAW)	Less than 3/32(2.4)	Less than 60	7	–
	3/32-5/32(2.4-4.0)	60-160	8	10
	5/32-1/4(4.0-6.4)	160-250	10	12
	More than 1/4(6.4)	250-550	11	14
Gas Metal Arc Welding (GMAW) Flux Cored Arc Welding (FCAW)		Less than 60	7	–
		60-160	10	11
		160-250	10	12
		250-500	10	14
Gas Tungsten Arc Welding(TIG)		Less than 50	8	10
		50-150	8	12
		150-500	10	14
Air Carbon Arc Cutting(CAC-A)	Light Heavy	Less than 500	10	12
		500-1000	11	14
Plasma Arc Cutting(PAC)		Less than 20	4	4
		20-40	5	5
		40-60	6	6
		60-80	8	8
		80-300	8	9
		300-400	9	12
		400-800	10	14
Plasma Arc Welding (PAW)		Less than 20	6	6-8
		20-100	8	10
		100-400	10	12
		400-800	11	14

Reference: ANSI Z49.1:2005

\* Start with a shade that is too dark to see the weld zone. Then, go to a lighter shade which gives a sufficient view of the weld zone without going below the minimum.

### 3-6. Sensitivity Control

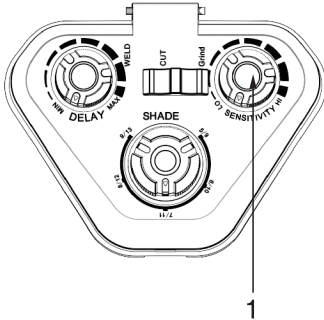

#### 1 Sensitivity Control

##### **Cut/Weld Mode**

Use control to make the lens more responsive to different light levels in various welding/Cutting processes. **Use a Mid-Range or 30–50% sensitivity setting for most applications.**

It may be necessary to adjust helmet sensitivity to accommodate different lighting conditions or if lens is flashing On and Off.

##### **Grind Mode**

 Do not weld in the Grind mode; the lens will not darken.

#### **Recommended Sensitivity Settings**

Stick Electrode	Mid-Range
Short Circuiting (MIG)	Low/Mid-Range
Pulsed & Spray (MIG)	Mid-Range
Gas Tungsten Arc (TIG)	Mid/High-Range
Plasma Arc Cutting/Welding	Low/Mid-Range
Grind Mode	Grind Position – Far Right (Clockwise)

### 3-7. LED Control Function

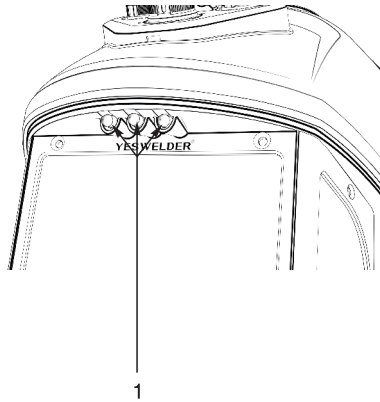

- 1 LED Lamp
- 2 LED Control

The lighting function can be kept on all the time and change with the light.

LED lights are used by charging (expected to be full in 4 hours) :

- The welding helmet is used when the light is not turned on, and can work for one month under the maximum color number;
  - The welding helmet is used when turning on the light, and under the maximum colour number, can work for about one day.
- 
- LED control function can be used to control "OFF" "ON" "Auto" mode.

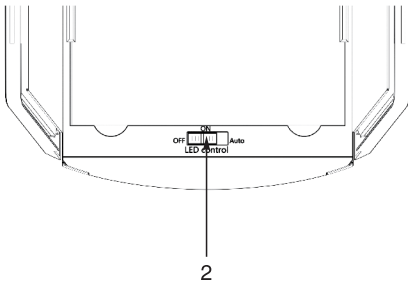

## SECTION 4 – ADJUSTING HEADGEAR

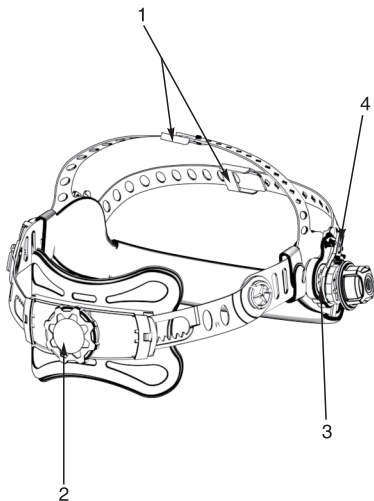

☞ *There are four headgear adjustments: headgear top, tightness, angle adjustment, and distance adjustment.*

### 1 Headgear Top

Adjusts headgear for proper depth on the head to ensure correct balance and stability.

### 2 Headgear Tightness

To adjust, push in the adjusting knob located on the back of the headgear and turn left or right to desired tightness.

☞ *If adjustment is limited, it may be necessary to remove the comfort cushion.*

### 3 Distance Adjustment

Adjusts the distance between the face and the lens. To adjust, loosen both outside tension knobs and press inward to free from adjustment slots. Move forward or back to desired position and retighten. (Both sides must be equally positioned for proper vision.)

### 4 Angle Adjustment

Four pins on the right side of the headband top provide adjustment for the forward tilt of the helmet. To adjust, loosen the right outside tension adjustment knob then lift on the control arm tab and move it to the desired position. Retighten tension adjustment knob.

☞ *When using the back distance adjustment positions, only the back three angle adjustment pins can be used.*

## SECTION 5 – REPLACING THE LENS COVERS

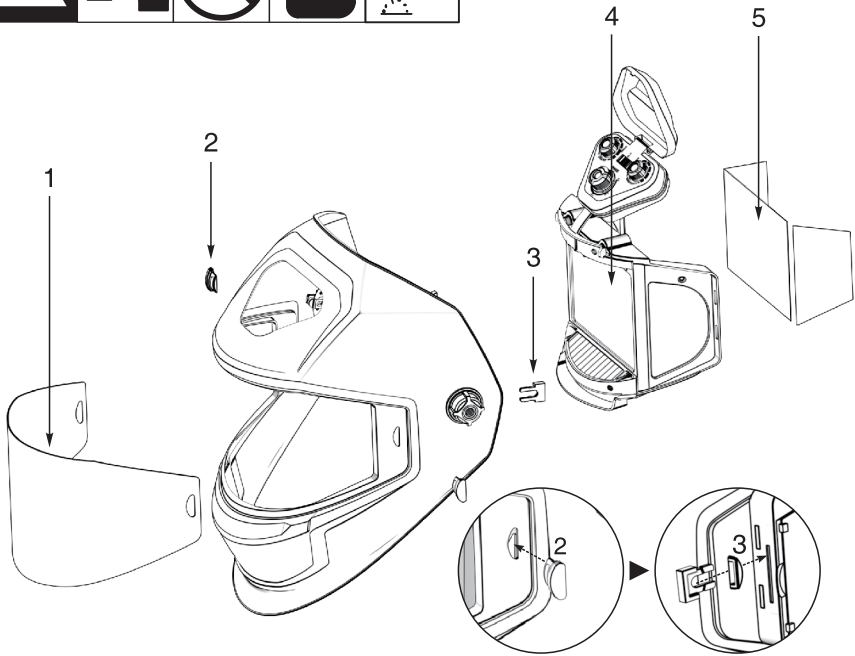

**⚠** Never use the auto-darkening lens without the inside and outside lens covers properly installed. Welding spatter will damage the auto-darkening lens and void the warranty.

1. Outside Lens Cover
2. Outside 2 Snaps
3. Inside 2 Snaps
4. Lens Assembly
5. Auto-darkening Filter

### Outside Lens Cover

Remove the snaps on the sides of the inside from the square direction. Take out the left parts of the snaps. The

outside lens cover is set free and you can reinstall it.

### Inside Lens Cover

Remove the inside lens cover by prying cover from groove in gasket and reinstall a new one.

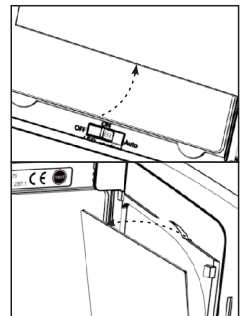

## SECTION 6 – CHARGE

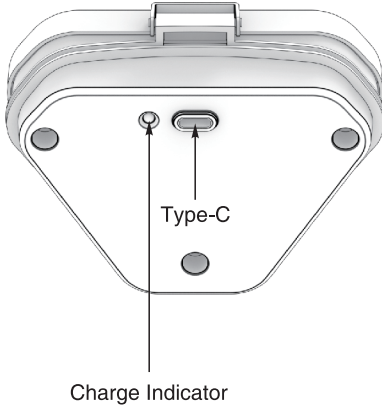

When the low battery is alarming, please charge the battery with the dedicated Type-C cable.

The charge indicator is red when it's charged, and green when it's fully charged.

## SECTION 7 – MAINTENANCE

---

**NOTICE** – *Never use solvents or abrasive cleaning detergents.*

**NOTICE** – *Do not immerse the lens assembly in water.*

The helmet requires little maintenance. However, for best performance clean after each use. Using a soft cloth dampened with a mild soap and water solution, wipe the cover lenses clean. Allow to air dry. Occasionally, the filter lens and sensors should be cleaned by gently wiping with a soft, dry cloth.

The product is composed of two parts, the connection line can not be disassembled or hard drag! When disassembling the ADF, it is necessary to remove both parts at the same time and then remove them from the helmet body!



## SECTION 8 –TROUBLESHOOTING GUIDE



Trouble	Remedy
Auto lens not ON – auto-lens will not darken momentarily when the Reset button is pressed.	Check batteries and verify they are in good condition and installed properly. Also, check battery surfaces and contacts and clean if necessary. Check battery for proper contact and gently adjust contact points if necessary. This is particularly important if the helmet has been dropped. Verify left and right battery trays are installed on the correct sides.
Not switching – auto-lens stays light and will not darken when welding.	Stop welding immediately; Press the Reset button if lens is Auto-On type. If lens is Manual-On type, make sure the lens is turned On. If power is on, review the sensitivity recommendations and adjust sensitivity. Clean lens cover and sensors of any obstructions. Make sure the sensors are facing the arc; angles of 45° or more may not allow the arc light to reach the sensors.
Not Switching – auto-lens stays dark after the weld arc is extinguished, or the auto-lens stays dark when no arc is present.	Fine-tune the sensitivity setting by making small adjustments to the control by turning it toward the “min” setting. In extreme light conditions, it may be necessary to reduce the surrounding light levels.
Sections of the auto-lens are not going dark, distinct lines separate the light and dark areas.	Stop welding immediately; The auto-lens may be cracked which can be caused by the impact of dropping the helmet. Weld spatter on the auto lens may also cause cracking. (The lens may need to be replaced; most cracked lenses are not covered by warranty).
Switching or Flickering – the auto-lens darkens then lightens while the welding arc is present.	Review the sensitivity setting recommendations and increase the sensitivity if possible. Be sure the arc sensors are not being blocked from direct access to the arc light. Check the lens cover for dirt and spatter that may be blocking the arc sensors. Increasing Lens Delay 0.1 – 0.3 second may also reduce switching.
Inconsistent or lighter auto-lens shading in the dark-state, noticeable on the outside edges and corners.	Referred to as an angle of view effect, auto-darkening lenses have an optimum viewing angle. The optimum viewing angle is perpendicular or 90° to the surface of the auto-lens. When that angle of view varies in the dark-state, welders may notice slightly lighter areas at the outside edges and the corners of the lens. This is normal and does not represent any health or safety hazard. This effect may also be more noticeable in applications where magnifying lenses are used.

## SECTION 9 – HEADBAND INSTALLATION

### Description of Headband Installation

Take out the headband, and disassemble it according to the exploded view below:

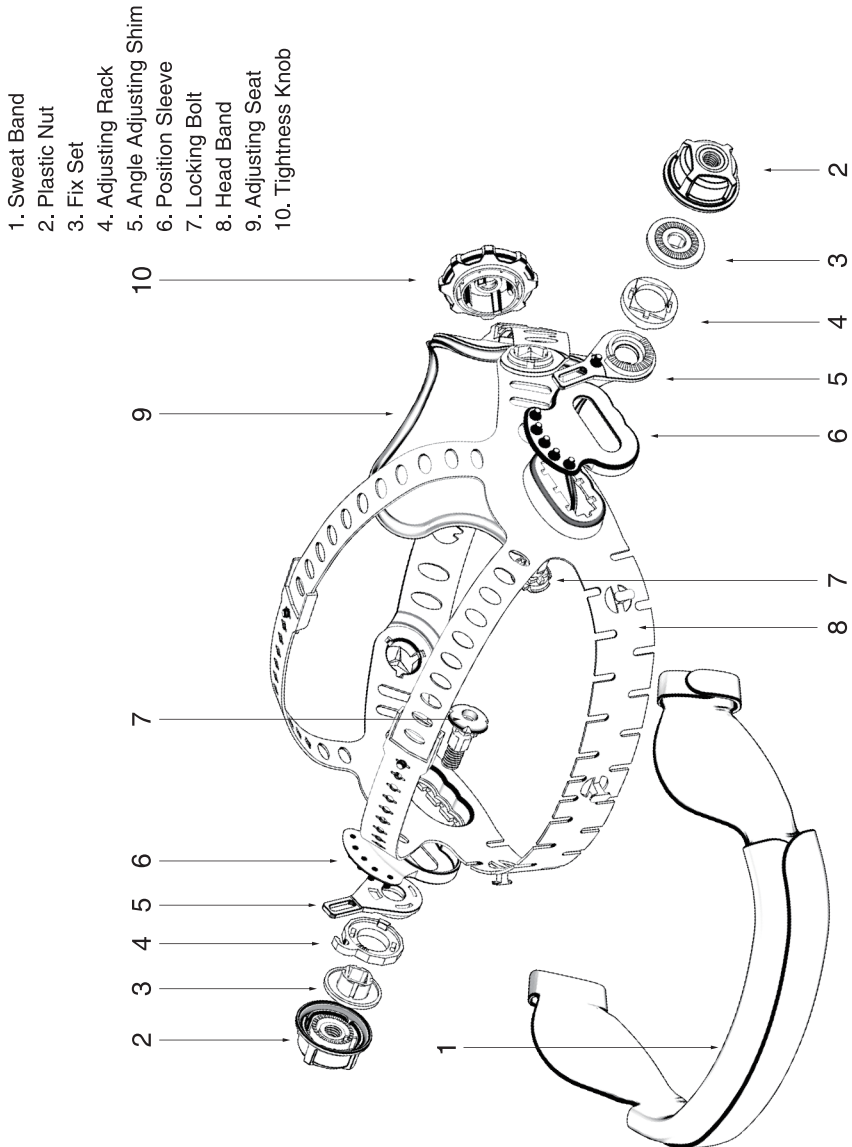

## SECTION 10 – LIMITED WARRANTY

---

**LIMITED WARRANTY** – Subject to the terms and conditions below. YESWELDER, warrants to its original retail purchaser that the new YESWELDER equipment sold after the effective date of this limited warranty is free of defects in material and workmanship at the time it is shipped by YESWELDER. THIS WARRANTY IS EXPRESSLY IN LIEU OF ALL OTHER WARRANTIES, EXPRESS OR IMPLIED, INCLUDING THE WARRANTIES OR MERCHANTABILITY AND FITNESS.

YESWELDER auto-darkening lens helmets are warranted for 1 years from the date of purchase. Proof of purchase is required for warranty transactions so it is imperative that a copy of the original invoice or sales receipt be retained.

**For warranty transactions, contact your YESWELDER Distributor.**

Effective January 1, 2020

Toll Free (855) 937-4567

**YESWELDER<sup>®</sup>**

[support@yeswelder.com](mailto:support@yeswelder.com)