



T25 Tube Compressor



OPERATOR'S MANUAL

Written for Automated Processes Incorporated
by Dan Pfeifer
Rev. 21-04-26

Table of Contents

About This Manual	1
1.0 Introduction	3
1.1 Features	3
2.0 Quick Start.....	4
3.0 Overview	5
4.0 Compressor Controls	6
4.1 Attack Time	6
4.2 Release Time	6
4.3 Ratio	6
4.4 Input Level – Threshold	6
4.5 Output Level – Make-up Gain	6
5.0 Side-Chain and Routing Controls	7
5.1 De-esser (D-S)	7
5.2 THRUST ®	7
5.3 IN/out Switch	8
5.4 Bypass Switch	8
5.5 Stereo Link Switch	8
6.0 Level Indication	9
6.1 Gain Reduction Meter & Peak Indicator	9
6.2 VU Meter	9
7.0 Tube Vent Window.....	9
8.0 Power Switch & Rear Panel Connections	10
8.1 Power Switch	10
8.2 Rear Panel	10
8.2.1 Audio Connections	10
8.2.2 AC Power	10
APPENDIX.....	11
A1 Technical Specifications.....	12
A2 Block Diagram	12
A3 Recall Chart.....	13
A4 User Accessible Maintenance	14
A4.1 Tube Replacement	14
A4.2 VU Meter Level Jumper.....	14
A5 API Limited Warranty and Service Information	15

About This Manual

This manual explains the operation and applications of the API Select T25 Tube Compressor. This manual is organized in sections that correspond to the front panel controls and rear panel interface.

Legend:

- **UPPER-CASE BOLD = POTS, CONTROLS, SWITCHES, BUTTONS**
- UPPER-CASE = REAR PANEL CONNECTIONS

Manual Revision History: YY-MM-DD format

Original: 21-04-26

Revised:

**Dan Pfeifer is a Professor of
Recording Industry at
Middle Tennessee State University**

Important Safety Instructions

1. Please read these instructions
2. Keep this information in a safe place
3. Do not use this device near water
4. Clean only with a dry cloth
5. This product uses high-voltage vacuum tube technology. To avoid a potentially-lethal shock, handle it with care. Never open the lid when the unit is on.
6. Wait at least 5 minutes after the unit has been unplugged before opening the lid to replace tubes. Reinstall lid before powering.
7. Do not block any ventilation openings
8. Do not stick object(s) through the top, side or front panel vents.
9. Allow at least 1U of empty rack space above the unit for tube ventilation.
10. The rear panel is a heatsink and will get warm. Leave at least a few inches of space around the rear panel area to allow for proper power supply cooling. Do not touch the rear panel surface for an extended period of time when the unit is powered on.
11. Do not install near any heat sources such as radiators, heat registers, stoves, or other devices that produce heat
12. Do not defeat the safety purpose of the polarized or grounding type AC plug
13. Protect the AC power cord from being walked on or pinched
14. Use only attachments/accessories specified by the manufacturer
15. Unplug this device during lightning storms or when unused for long periods of time
16. Refer all service to qualified personnel

ATTENTION: Exposure to extremely high noise levels may cause permanent hearing loss or damage. Individuals vary considerably in susceptibility to noise-induced hearing loss, but nearly everyone will lose some hearing if exposed to sufficiently intense noise (this may include music) for a period of time. Be safe.

WARNING – To reduce the risk of fire or electric shock, do not expose this apparatus to rain or moisture.

1.0 Introduction

Welcome to the API Select line of premium tube-based audio processors and thank you for choosing the T25 Tube Compressor. The T25 is a classic 2-channel, F.E.T. feedback-style compressor/limiter with a Class-A tube output stage that utilizes a custom API transformer. Built with 12AT7WC and 12BH7 dual-triode vacuum tubes, the T25 represents the next step in API's compression technology and new vistas of tonal shaping while retaining the unmistakable API sound quality. The result is one of the world's best sounding tube compressors that's capable of handling an infinite number of production applications, including stereo operation. Carefully designed to deliver a wide range of compression options, the T25 delivers warmth, clarity and punch, whether used for subtle adjustments or heavy compression effects.

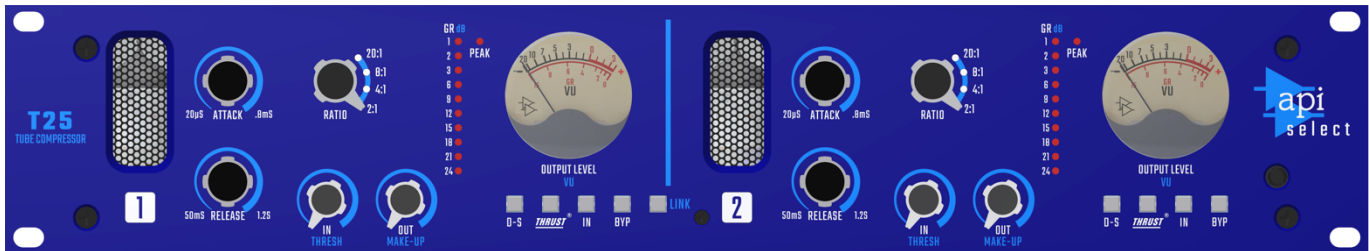

1.1 Features

- Field Effect Transistor (F.E.T.) based gain reduction circuit
- Audio circuit uses 12AT7WC and 12BH7, dual-triode vacuum tubes with custom transformer output
- 11-step attack time switch
- 11-step release time switch
- 4 fixed ratios
- 31-step input/threshold control
- 31-step output/make-up gain control
- Detented controls for accurate recall
- Patented **THRUST**[®] filter for low-frequency dependent side-chain control
- D-S feature provides high-frequency dependent side-chain control for de-essing
- Link switch for stereo operation
- 10-segment LED gain reduction meter
- LED peak indicator
- Vintage looking VU meters indicate output levels
- IN/out switch
- Full hard-wired relay bypass
- XLR and ¼" TRS input and output connections

The T25 Tube Compressor has several unique features that will allow you to tailor the sound of the compression in many different directions.

The patented **THRUST**[®] inserts a filter in front of the RMS detector that evens out the energy by lowering the energy in the low frequencies and increasing the energy in the high frequencies, so each octave has the same energy instead of each octave having half the energy as the one lower. This creates a unique compression effect that still reduces the overall gain, but the sound is much more punchy and the signal actually sounds much less compressed.

The **D-S** feature accentuates compression of high-frequency content (bell curve w/ 6kHz center) for use as a vocal de-esser.

2.0 Quick Start

One tip to get started: We try to design all of our processing modules with the understanding that there is never enough time to read a manual and learn all of the features in the 10 seconds that is allowed during a setup. If you simply set all of the parameters as follows the T25 will have a useful, but conservative effect on the signal.

After the unit has been powered on and warmed up*:

- Set the following knobs to the 12:00 position
 - ATTACK
 - RELEASE
 - IN **THRESHOLD**
 - OUT **MAKE-UP**
- Set RATIO to 2:1
- Engage the IN switch
- Disengage the D-S, **THRUST**[®], BYP, and **LINK** switches

These settings will provide a good starting place for additional tweaking to achieve the desired sound.

**NOTE: The T25 is a tube-based processor that requires 15 minutes for the tubes to warm-up to a stable temperature before tonal qualities become consistent.*

3.0 Overview

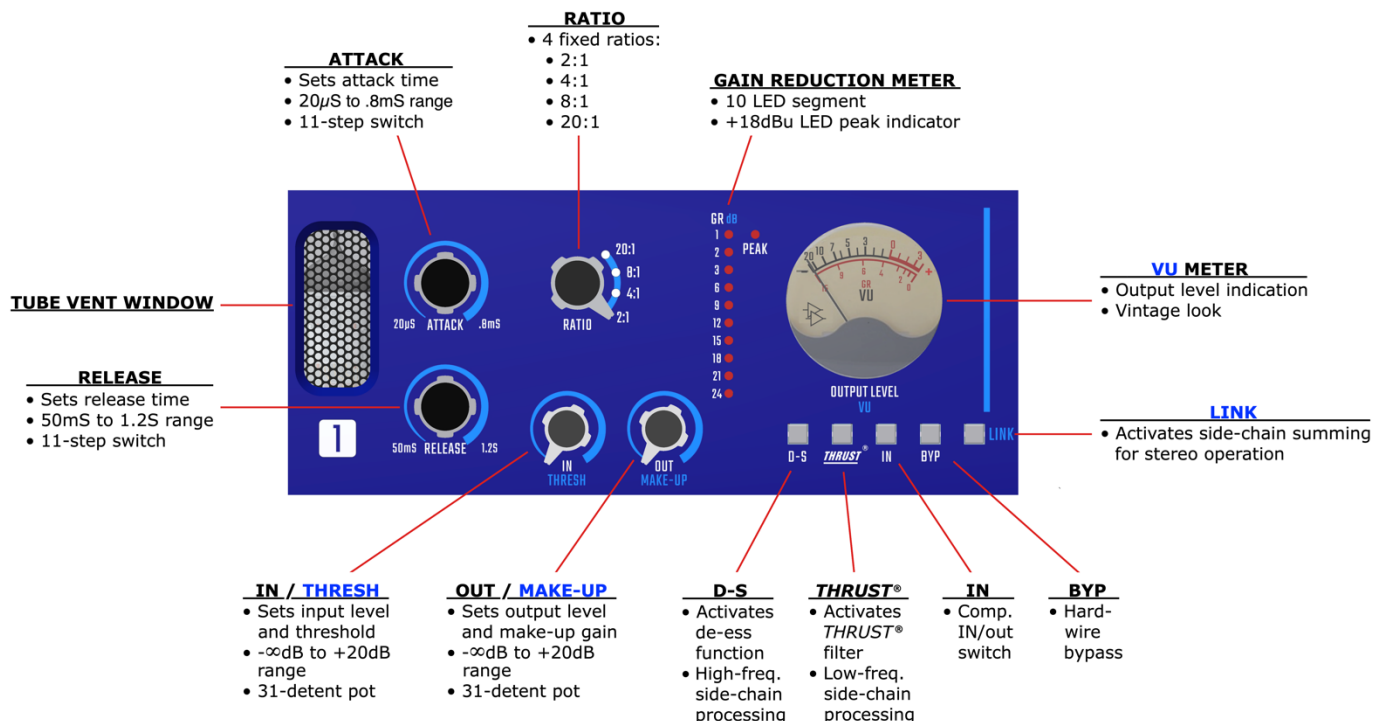

The T25 Tube Compressor provides a comprehensive suite of controls:

- **ATTACK**: Sets the time it takes the compressor to respond after levels rise above threshold
- **RELEASE**: Sets the time it takes the compressor to return to unity gain after levels fall below threshold
- **RATIO**: Sets the amount of compression applied to levels above threshold
 - Four fixed ratios: 2:1, 4:1, 8:1, and 20:1
- **IN THRESH** (Input/Threshold): Sets the input level/threshold
 - Sets the level at which compression begins (threshold)
- **Out MAKE-UP** (Output/Make-up Gain): Sets the compressor output level/make-up gain
- **D-S**: Toggles to activate the de-esser function
 - Accentuates compression of high-frequency content
- **THRUST®**: Toggles to activate the patented **THRUST®** filter circuit
 - Reduces heavy low-frequency content in the detection path
- **IN**: Toggles to switch compression IN or out
- **BYP** (Bypass): Toggles to engage the hard-wire bypass
- **LINK**: Toggles to link channels 1 and 2 for stereo operation
- **GR**: 10-segment LED gain reduction meter
- **PEAK**: +18dBu LED peak indicator
- **OUTPUT LEVEL VU**: Back-lit, vintage looking output **VU** meter

4.0 Compressor Controls

Each channel of the T25 is equipped with a comprehensive set of compression parameters.

4.1 Attack Time



ATTACK: Sets the time it takes the compressor to react when levels exceed the set **THRESHOLD**

- 20µS to .8mS range
- 11-step switch

4.2 Release Time



RELEASE: Sets the time it takes the compressor to recover to unity gain after levels fall below the set **THRESHOLD**

- 50mS to 1.2S range
- 11-step switch

4.3 Ratio



RATIO: Simultaneously sets the compression ratio (input vs. output) and adjusts the threshold level for optimal settings

- Four fixed ratios: 2:1, 4:1, 8:1, and 20:1
- 4-step switch
- Compression with high ratios is generally considered to be limiting

4.4 Input Level – Threshold



IN THRESH (Input/Threshold): Sets the input level/threshold

- Determines the level at which compression begins
- $-\infty$ dBu to +20dBu range
- 31-step detented control

4.5 Output Level – Make-up Gain



OUT MAKE-UP (Output Level- Make-up Gain): Sets the output level/make-up gain

- Post gain-reduction and pre tube output stage
- $-\infty$ dBu to +20dBu range
- 31-step detented control

5.0 Side-Chain and Routing Controls

The T25 Tube Compressor is equipped with a flexible set of side-chain processes and routing controls. Frequency-dependent side-chain processing includes a de-esser and the patented **THRUST**[®] filter that helps you get more punch from audio with heavy low-frequency content. These features provide increased control of the tonal characteristics and envelope shaping the compression applies to the audio.

Routing options provide a compressor IN/out switch, hard-wire bypass, and linking for stereo operation.

5.1 De-esser (D-S)

The **D-S** function provides a de-esser capability to the T25 for working with overly sibilant vocals.



D-S: Engage to activate the de-esser function

- Accentuates compression of high-frequency content
- Inserts a filter with 6kHz center before the RMS detector
- Illuminates when engaged

5.2 **THRUST**[®]

The T25 Tube Compressor is equipped API's patented **THRUST**[®] filter circuit that can be switched in or out of the side-chain as needed. This places the **THRUST**[®] filter before the RMS detector that decreases the compressor's reaction to low frequency content. The result is a noticeable increase of punch and low frequencies, but a uniformly compressed signal. It's the "little more punch" switch!



THRUST[®]: Engage to activate the **THRUST**[®] filter function

- Controls heavy low-frequency content in the detection path
- Inserts a 10dB/decade filter before the RMS detector
- Illuminates when engaged

The patented **THRUST**[®] circuit has been used for many years in the famed API 2500+ Stereo Compressor, ATI Paragon and Paragon II consoles, as well as the Pro6 Input Strip. This circuit places a filter in front of the RMS detector with a slope of 10dB per decade (-3dB/8va), which is the inverse of the pink noise energy curve. In acoustics, the pink noise curve is used to equalize energy vs. frequency over the audio spectrum, as sound requires more low frequency energy than high frequency energy to sound correct to your ear. In Hi-fi equipment, a "LOUDNESS" contour is used to equalize the music at lower levels so it sounds correct. Even with this curve, there is still a substantial amount of low frequency information compared to high frequency information in the audio signal path. When that signal is fed into the RMS detector, the detector will process the signal into a DC control voltage based upon those louder low frequencies, resulting in a control voltage that favors the low frequencies of the signal, causing pumping and a loss of punch. Sometimes, this is not desirable. By engaging the **THRUST**[®] switch, this inverse filter is placed in front of the RMS detector, evening out the energy by lowering the energy in the low frequencies and increasing the energy in the high frequencies, so each octave has the same energy instead of each octave having half the energy as the one lower. This creates a unique compression effect that still reduces the overall gain, but the sound is much more punchy and the signal actually sounds less compressed.

5.3 IN/out Switch

The **IN** switch is a soft IN/out button that defeats the compression action silently, but allows the signal to pass through the FET amplifier and tube circuitry.



IN: Toggle to switch compression IN or out

- Activates gain reduction when engaged
- Audio passes through T25 circuitry without gain reduction when disengaged
- Illuminates when engaged

5.4 Bypass Switch

The **BYP** (Bypass) switch is a relay hard-wired bypass that routes the signal directly from the INPUT XLR to the OUTPUT XLR, without going through any electronics.



BYP (Bypass): Toggle to engage the hard-wire bypass

- Signal bypasses all T25 circuitry when engaged
- Illuminates when engaged

NOTE: When the T25 is powered off, BYP is engaged allowing audio to pass directly through the device. This allows the T25 to be powered off when not in use in order to prolong tube life.

5.5 Stereo Link Switch

The channels 1 and 2 of the T25 Tube Compressor function can be linked together for stereo operation. This will prevent “center-image shifting” caused by differing amounts of gain reduction on each channel when compressing correlated stereo signals and mixes. Examples include stereo piano or guitar, drum overheads, or any other audio recorded with a stereo array. The T25 can also be used as stereo mix bus compressor when used in linked mode.

The controls on both channels must all be set exactly the same in order to achieve equal gain reduction on both sides of a stereo program when the link is engaged.



LINK: Toggle to link channels 1 and 2 for stereo operation

- Activates side-chain summing before the RMS detectors
- Set controls on both channels identically for equal gain reduction

6.0 Level Indication

Each channel of the T25 Tube Compressor is equipped with a LED gain reduction meter, a peak indicator, and output level VU meter for level indication.

6.1 Gain Reduction Meter & Peak Indicator

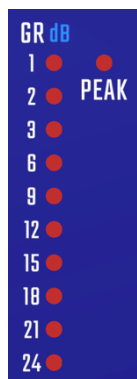

GR (Gain Reduction): Indicates the amount of gain reduction in decibels (**dB**)

- Up to ten red LEDs illuminate to provide accurate indication of gain reduction

PEAK: Indicates when output level reaches or exceeds +18dBu

- Red LED

6.2 VU Meter



OUTPUT LEVEL VU: Indicates the signal level at the OUTPUT connector

- 0VU is +4dBu (factory setting)
- 0VU = +14dBu option with internal jumper adjustment
- Vintage look
- Backlit

NOTE: The T25 VU meter cannot display gain reduction.

7.0 Tube Vent Window

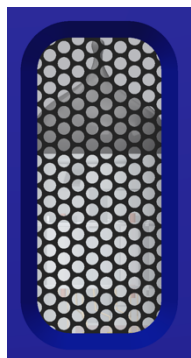

The T25 Tube Compressor is equipped with metal-grate vent window that provides ventilation for cooling and allows the tubes to be seen. This vent window should never be blocked when the unit is powered on.

8.0 Power Switch & Rear Panel Connections

8.1 Power Switch

The power switch for the T25 Tube Compressor is located on the right side of the front panel.

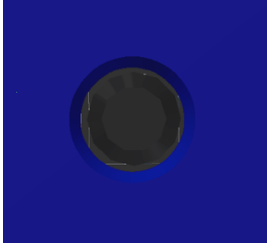

Power: Toggle to power the T25 ON and off

NOTE: The T25 is a tube-based processor that requires 15 minutes for the tubes to warm-up to a stable temperature before tonal qualities become consistent.

8.2 Rear Panel

The rear panel of the T25 Tube Compressor provides audio inputs and outputs for both channels connections, as well as AC power connection, voltage selection, and fuse.

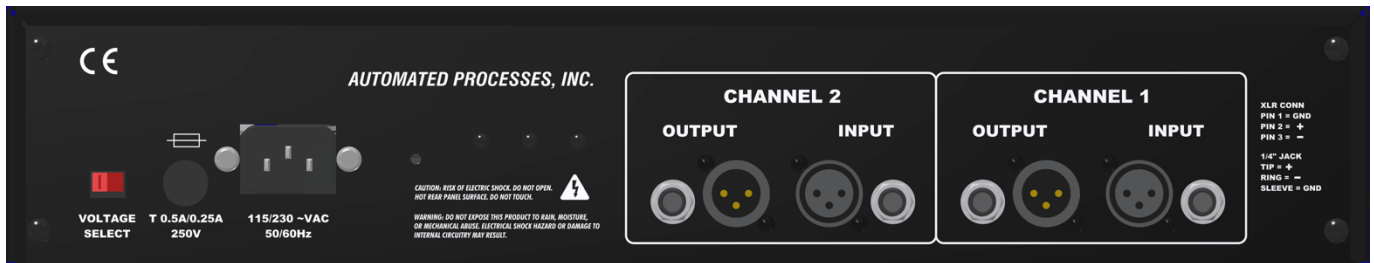

8.2.1 Audio Connections

Each audio channel, Left and Right, has an INPUT and OUTPUT connection.



IMPORTANT NOTE: The XLR and 1/4" INPUT connectors are wired together, so use only one INPUT connection a time.

IMPORTANT NOTE: Care should be taken not to short the outputs, as damage will occur to the output stage.

8.2.2 AC Power

The AC power connection, fuse, and voltage selection switch is located on the rear panel of the T25.

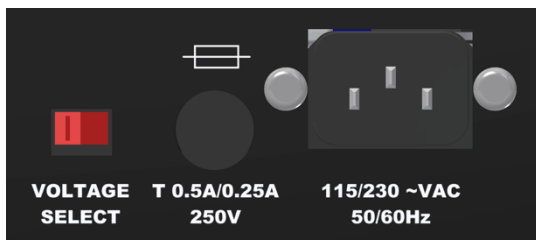

115/230V~: Voltage selection switch

Fuse: 0.5A/0.25A 250V

- 115VAC value factory installed
- Change to appropriate value for 230VAC operation

AC Power Connection: Standard IEC power cable

APPENDIX

A1 Specifications

A2 Block Diagram

A3 Recall Chart

A4 User Accessible Maintenance

A5 API Limited Warranty and Service

A1 Technical Specifications

- **Input Impedance:** 20kΩ
- **Output impedance:** 75 ohms, can drive 600 ohm **loads**
- **Maximum output level:** +24dBu
- **Frequency Response:** 20Hz – 40kHz (+0dB / -1dB)
- **Ratios:** 2:1, 4:1, 8:1, 20:1 (switchable)
- **Attack Times:** 20μs – 0.8ms
- **Release Times:** 50ms to 1.2s
- **Total Gain:** +40dB, IN/OUT both fully CW
- **SNR:** 90dB
- **Power Consumption:** 45W
- **Size:** 19" x 3.5" x 12" Deep
- **Size (Boxed for Shipping):** 21" x 9" x 15"
- **Actual Weight:** 14 lbs.
- **Shipping Weight:** 17 lbs.

A2 Block Diagram

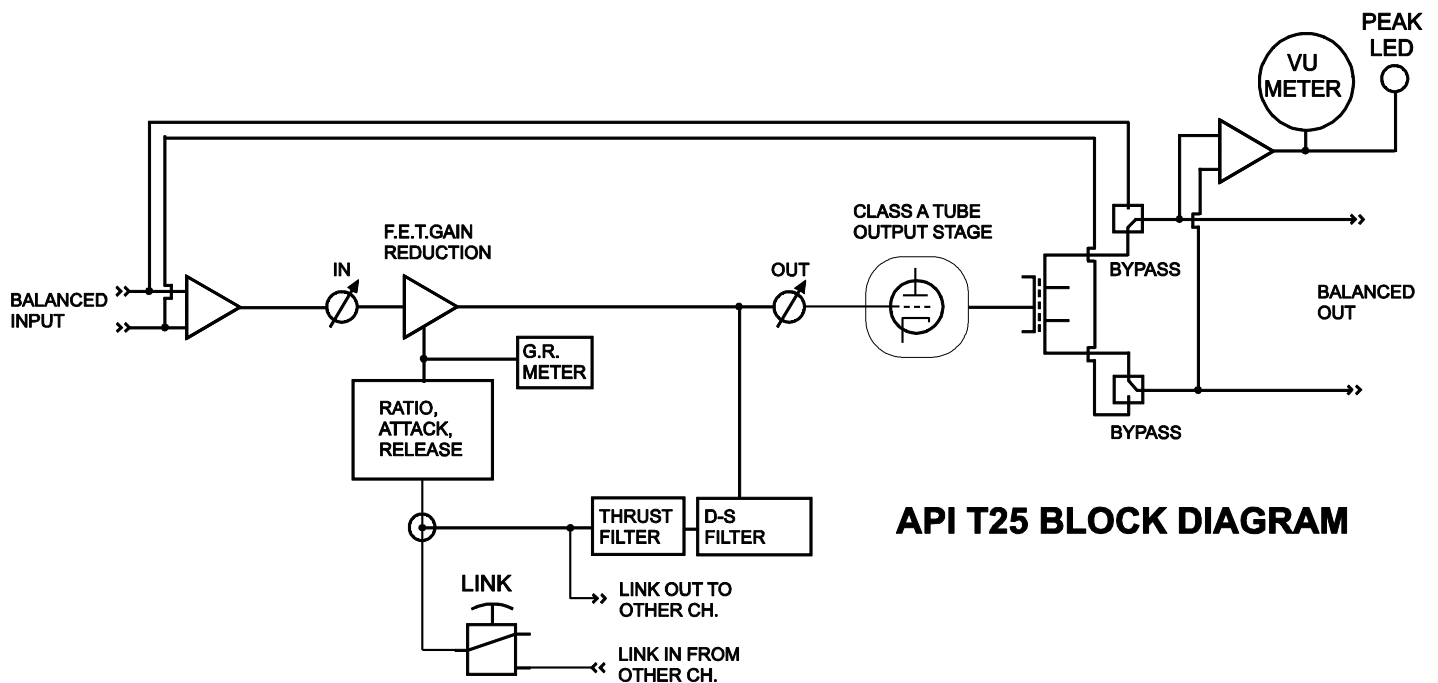

A3 Recall Chart



T25 RECALL CHART

ARTIST:
ENGINEER:
DATE:

NOTES:
DRAWN BY:
STUDIO:

T25 TUBE COMPRESSOR

Channel 1 controls: Threshold, Ratio, Attack (200µs), Release (50ms), Output Level, D-S, Z-BASS, IN, BYP, LINK, and a numeric display showing '1'.

Channel 2 controls: Threshold, Ratio, Attack (200µs), Release (50ms), Output Level, D-S, Z-BASS, IN, BYP, LINK, and a numeric display showing '2'.

API Select logo and 'api select' text are visible at the top of the panel.

NOTES:

T25 TUBE COMPRESSOR

Channel 1 controls: Threshold, Ratio, Attack (200µs), Release (50ms), Output Level, D-S, Z-BASS, IN, BYP, LINK, and a numeric display showing '1'.

Channel 2 controls: Threshold, Ratio, Attack (200µs), Release (50ms), Output Level, D-S, Z-BASS, IN, BYP, LINK, and a numeric display showing '2'.

API Select logo and 'api select' text are visible at the top of the panel.

NOTES:

A4 User Accessible Maintenance

A4.1 Tube Replacement

The T25 Tube Compressor features 12AT7WC and 12BH7 dual-triode vacuum tubes in each channel. The factory installed tubes are selected at API for optimal performance.

All tubes are socketed and can be replaced if required.

- Make sure power switch is off
- Make sure the unit has been unplugged for at least 5 minutes before opening the chassis
- Four screws on sides remove the lid and allow access to the printed circuit board
- No user tube bias adjustments

A4.2 VU Meter Level Jumper

A marked internal jumper selects between 0VU = +4dBu and 0VU = +14dBu for the **OUTPUT LEVEL** **VU** meter (one per channel).

- Make sure power switch is off
- Make sure the unit has been unplugged for at least 5 minutes before opening the chassis
- Four screws on sides remove the lid and allow access to the printed circuit board
- No user calibration adjustments

A5 API Limited Warranty and Service Information

- a) **Warranty Information:** API products carry a one year factory service and five year parts warranty from date of purchase. API (Automated Processes, Incorporated) does not cover claims for damage due to alteration and/or abuse. This warranty is limited to failures during normal use, which are due to defects in material or workmanship. If any defects are found in the materials or workmanship, or if the product fails to function properly during the applicable warranty period, API, at its option, will repair or replace the product. **NOTE: Vacuum Tube part warranty is limited to 90 days from date of purchase.**
- b) **PLEASE NOTE:** The design or quality of any non-authorized third party service or vendor is beyond the control of API. Therefore, use of **NON-API VPR Alliance modules in any API product – including consoles** may **VOID this warranty.** Also, service or modification of any API unit except by an authorized API representative may **VOID this warranty.**
- c) API reserves the right to inspect any products that may be the subject of any warranty claims before repair or replacement is carried out. Final determination of warranty coverage lies solely with API.
- d) This warranty is extended to the original purchaser and to anyone who may subsequently purchase this product within the applicable warranty period. Proof of purchase may be required.
- e) **For questions regarding operation, interfacing or service of your API product, please contact your API dealer from whom you purchased the unit. Many times, your authorized API dealer is the fastest and most cost-effective way to maintain and service your product.**
- f) The below steps are the best way to initiate the repair process or to submit a parts order request:

Repair procedure:

1. Fill out a Return Authorization (RA) form at service.apiaudio.com.
2. Wait to receive an e-mail from API Audio with an RA#.
3. Use the API original box to package the unit. Write the RA# large and legibly on the box (if the RA# is not clearly visible on the box, the unit may be rejected by our receiving department)
4. Include copy of the RA form with the unit.
5. Ship the product **freight prepaid** to:
API SERVICE DEPARTMENT
8301 Patuxent Range Road – Ste A1
Jessup, MD 20794

Parts Order procedure:

1. Fill out online PO form (for parts and parts numbers not listed online please fill out PO form with your name, e-mail, contact phone and shipping address and describe the part you need).
 2. Submit online PO form.
 3. API will e-mail you back with part numbers and procedure how to order/pay.
- g) This is your sole warranty. API does not authorize any third party, including any dealer or sales representative, to assume liability on behalf of API or to make any warranty for API.
 - h) THE WARRANTY GIVEN ON THIS PAGE IS THE SOLE WARRANTY GIVEN BY API AND IS IN LIEU OF ALL OTHER WARRANTIES, EXPRESS AND IMPLIED, INCLUDING THE WARRANTIES OF MERCHANTABILITY AND FITNESS FOR A PARTICULAR PURPOSE. THE WARRANTY GIVEN ON THIS PAGE SHALL BE STRICTLY LIMITED IN DURATION TO FIVE (5) YEARS FROM THE DATE OF THE ORIGINAL PURCHASE FROM API OR AN AUTHORIZED API DEALER. UPON EXPIRATION OF THE APPLICABLE WARRANTY PERIOD API SHALL HAVE NO FURTHER WARRANTY OBLIGATION OF ANY KIND. API SHALL NOT BE LIABLE FOR ANY INCIDENTAL, SPECIAL, OR CONSEQUENTIAL DAMAGES THAT MAY RESULT FROM ANY DEFECT IN THE API PRODUCT OR ANY WARRANTY CLAIM.
 - i) This warranty provides specific legal rights and you may have other rights, which vary from state to state.



Automated Processes, Inc.

©2021

**8301 Patuxent Range Road
Jessup, MD 20794 USA
301-776-7879**

<http://www.apiaudio.com>