

# SC9820 CHARGING & CONNECTIVITY STATION

## STANDARD SPECIFICATIONS

---

### HOUSING

Heat treated spun aluminum pole

### LAMP LENS / DIFFUSER

UV stabilized polycarbonate panel covering LED array.

### UNIT PERFORMANCE

2 x 6W LED array – 2.5 ft-candles | L70 rating: 75,000 hrs

5V/2A USB Output Charging Ports – 4 Pcs

Customizable RGB Color Changing LED Waypoint Ring

Optional Wifi Router for New or Existing Network

Fiberglass Wrapped Steel Table

36+hrs Autonomous Operation

Programmable Operation for Occupancy Control

### POWER COLLECTION

Monocrystalline Solar Panel – 20+ Years Lifespan

Adjustable Panel Orientation

### POWER STORAGE

Lithium-ion Industrial Battery Pack – 5+ Years Lifespan

### MOUNTING

Ground Mount - 4-hole pattern accepts up to 5/8" studs

### FINISH

Optional Anodized Aluminum or Natural Finish

### WARRANTY

Accompanied by 5 year limited warranty.

For ordering or questions please contact SELS USA at  
704-495-3535 or [CustomerService@SELSLED.com](mailto:CustomerService@SELSLED.com)  
2995 Starlight Dr, Winston-Salem, NC 27107

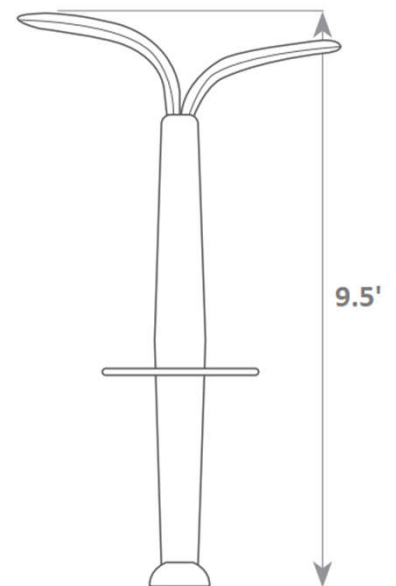

# SC9820 CHARGING & CONNECTIVITY STATION

## LIGHTING SPECIFICATIONS



### Optical Assembly Details

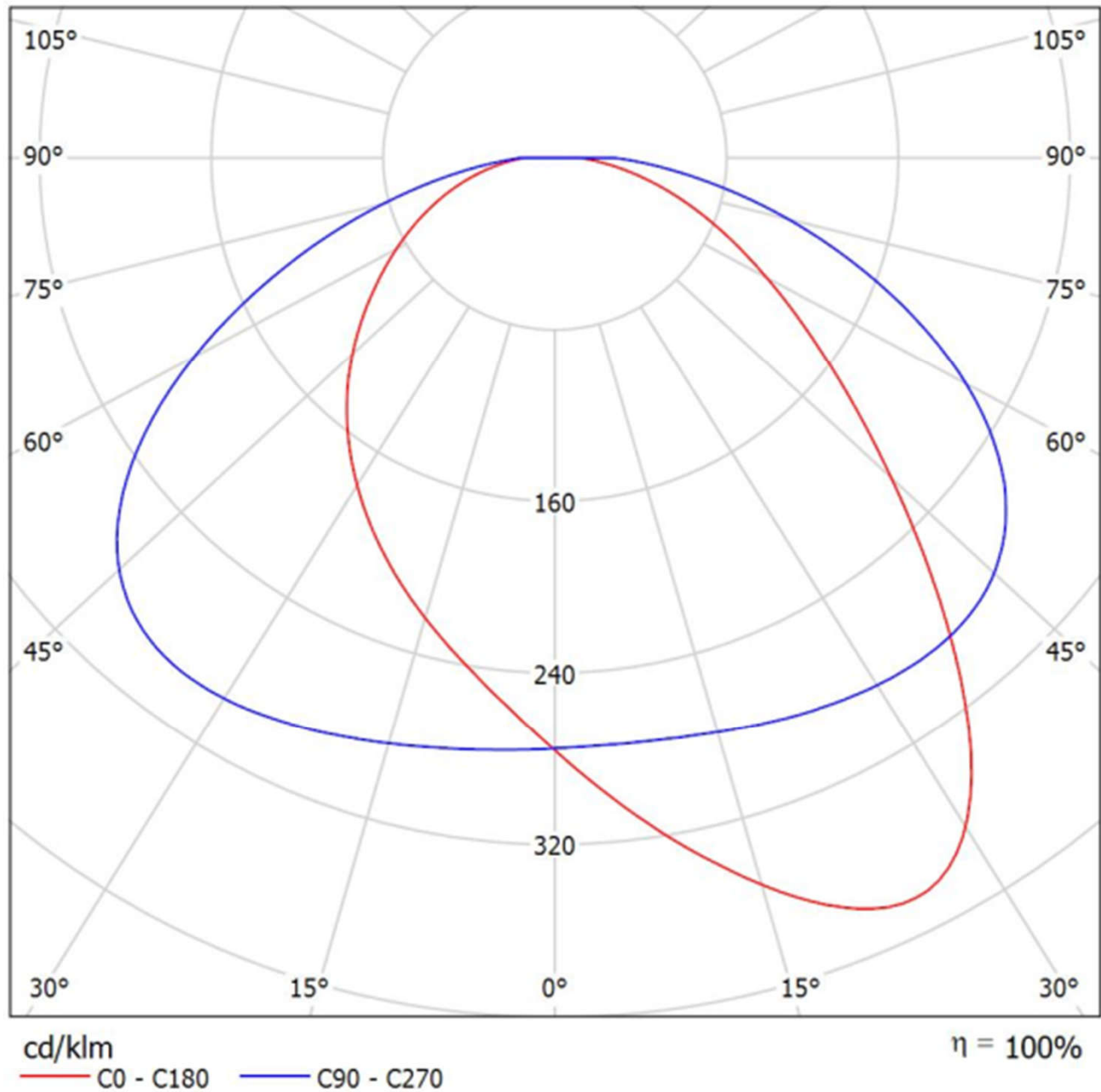

For ordering or questions please contact SELS USA at  
704-495-3535 or [CustomerService@SELSLED.com](mailto:CustomerService@SELSLED.com)  
2995 Starlight Dr, Winston-Salem, NC 27107