

# LOGAN 1075

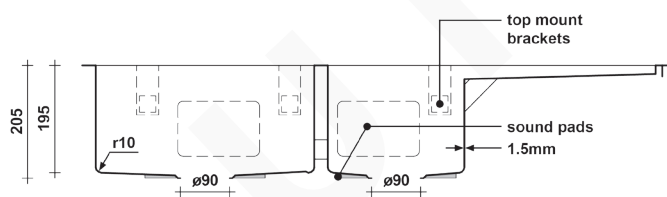
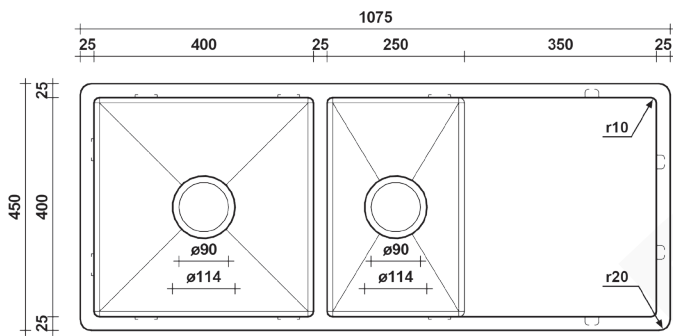

### AVAILABLE MODEL OPTIONS

- SNA01018 Logan 1075 Brushed Stainless Steel

### DESCRIPTION

- Brand: Alma
- Name: Logan 1075
- Model: SNA01018 Brushed Stainless Steel
- Type: Double bowl sink with drainboard
- Capacity: 53 Litres

### SPECIFICATIONS

- Sink size: 1075mm x 450mm
- Bowl size 1: 400mm x 400mm
- Bowl size 2: 250mm x 400mm
- Depth: 205mm
- Material: 304 grade stainless steel
- Thickness: 1.5mm / 16 gauge steel
- Finish: Brushed stainless steel
- Internal corner: R10
- External corner: R20

### INSTALLATION OPTIONS

- Under-mount / top-mount / flush-mount.

### INCLUSIONS

- Top mount brackets.
- Anti-condensation exterior coating.
- Sound pads to external faces and base.
- 90mm strainer waste and plug to each drain.

### WARRANTY

- 25 years manufacturer's warranty.
- Fit for Australian Standards and UPC certified.