

LINCOLN 825

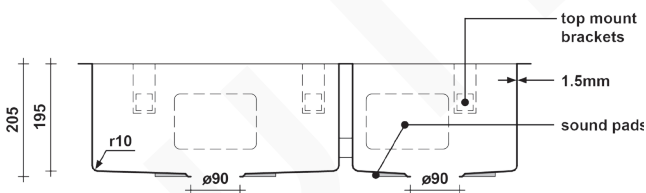
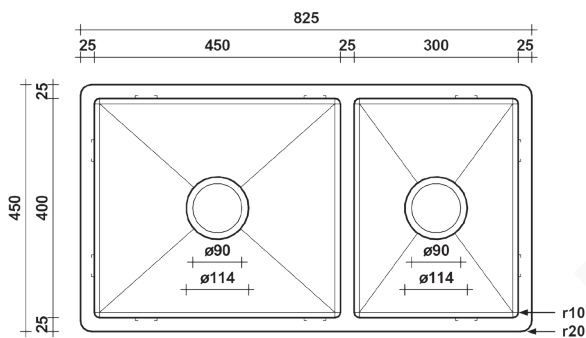

MODEL & AVAILABLE COLOUR OPTIONS

- SN101015 Lincoln 825 Brushed Stainless Steel
- SNGM015 Lincoln 825 Brushed Gunmetal
- SNGD015 Lincoln 825 Brushed Brass Gold

DESCRIPTION

Brand: Alma
 Name: Lincoln 825
 Model: SN101015 Brushed Stainless Steel
 Type: Double bowl sink
 Capacity: 61.5 Litres

SPECIFICATIONS

Sink size: 825mm x 450mm
 Bowl size 1: 450mm x 400mm
 Bowl size 2: 300mm x 400mm
 Depth: 205mm
 Material: 304 grade stainless steel
 Thickness: 1.5mm / 16 gauge steel
 Finish: Brushed stainless steel
 Internal corner: R10
 External corner: R20

INSTALLATION OPTIONS

- Under-mount / top-mount / flush-mount.

INCLUSIONS

- Top mount brackets.
- Anti-condensation exterior coating.
- Sound pads to external faces and base.
- 90mm strainer waste and plug to each drain.

WARRANTY

- 25 years manufacturer's warranty.
- Fit for Australian Standards and UPC certified.