



mockingbird



2nd Seat Kit

Expand your Stroller in a few easy steps!

Warning

Please follow all of these instructions to ensure the safety of your children. Keep these instructions for future reference. Failure to follow these instructions could result in serious injury or death.

Avoid serious injury from falling or sliding out. Always ensure that the child is properly positioned by using the safety harness according to these instructions.

Load heavier child into primary top seat first

After child is secure in the upper position, place second child into the bottom position. Do not place child in the bottom position without a child in the upper position.

If placing an infant in the upper position, unstable conditions may exist with toddlers greater than 35 lb in the lower position.

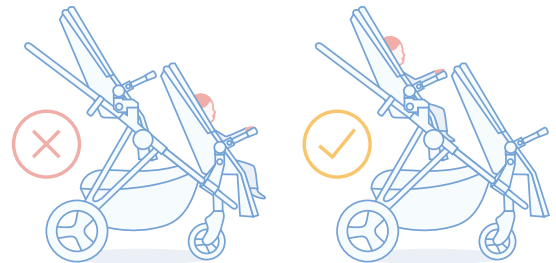

Choking Hazard

Adult assembly required because of small parts. Keep (assembly parts) out of reach of children under 3 years.

Caution

- Keep assembly parts out of reach of children under 3 years.
- Make sure the stroller is fully erect and latched in the open and locked position before allowing children near the stroller.
- Make sure all body parts are clear of the stroller when folding and unfolding.
- Never use the stroller on stairways or escalators
- Never use the stroller with roller skates or in-line skates
- Never leave children unattended
- The maximum weight that can be carried in the lower basket is 25 lbs (11.3 kg). Placing excessive weight in the unit or on the unit (e.g., purses, shopping bags, parcels, diaper bags, or accessory items) may change the balance of the stroller and cause hazardous/unstable conditions.
- Use of the stroller with children weighing more than 45 pounds or over 42 inches tall will cause excessive wear and stress on the stroller and may cause hazardous/unstable condition to exist.
- Never allow the stroller to be used as a toy

First, unpack the box and make sure you've got everything

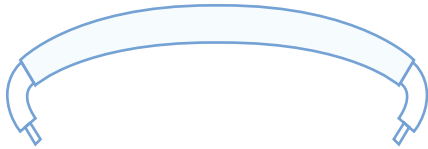

Child Bar

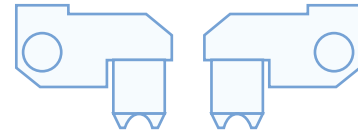

Upper Adapter

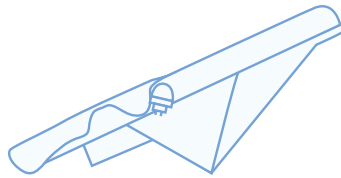

Stroller Seat

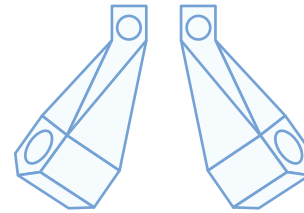

Lower Adapter

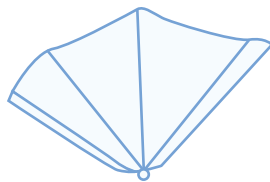

Extendable Canopy

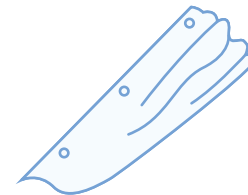

Sunshade

1

Attach the Child Bar

Attaching the Child Bar

Insert the pins located on the ends of the child bar into the housing located on the left / right side of the seat frame. The child bar “CLICKS” on both sides once it is in a fully locked position.

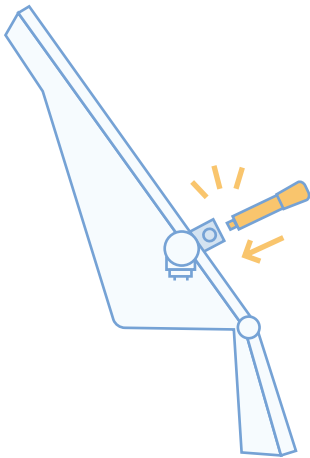

Removing the Child Bar

To remove, press the white buttons located just below either side of the child bar.

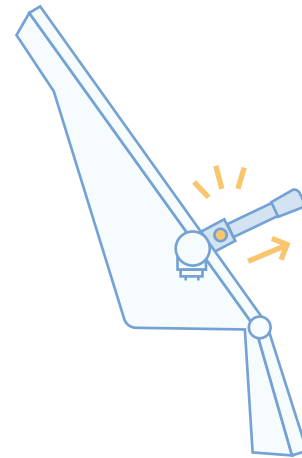

2

Attach the Canopy

Attaching the Canopy

Place the back of the canopy onto the top of the seat. Then, slide both sides of the canopy locks into both canopy housings located on the seat until it “CLICKS” into a fully locked position.

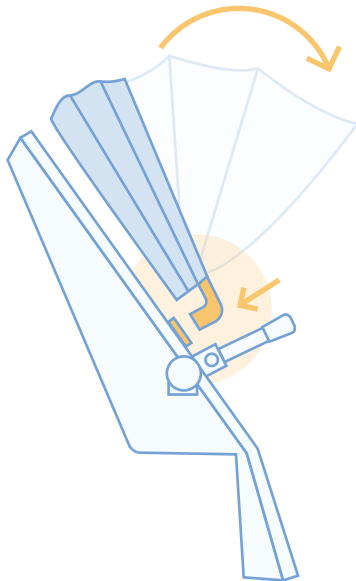

Securing the Canopy

Match up the velcro strips on the inside of the canopy with the velcro strips on the top of the seat. Secure the elastic loops on the left and right sides of the canopy onto the hooks located on the seat frame.

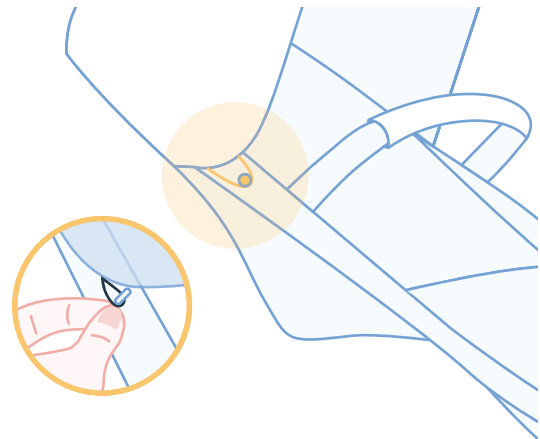

3

Attach the Upper Adapters

Attaching the Upper Adapters

Place the the upper adapters into the right and left joints. The white button on the upper adapter should be facing outward. The upper adapters “CLICK” on both sides once they are in a fully locked position. Pull upward on the Upper Adapters to ensure they are securely locked onto the stroller frame. Press the buttons located on the adapters to release.



4

Attach the Lower Adapters

Opening the Lower Adapters

Press the black release button on the inside of the Lower Adapter to release the latch, opening the hinged door. With the white button facing outward, place the open hinged door so that it can clasp around the bottom of the frame, just above the plastic footwell.

Attaching the Lower Adapters

Bring the hinged door around the frame. When the hinged door is secured, it will “CLICK” in place once it is in a fully locked position. Repeat on the other side with the second Lower Adapter. Press the buttons located on the outside of the adapters to release.

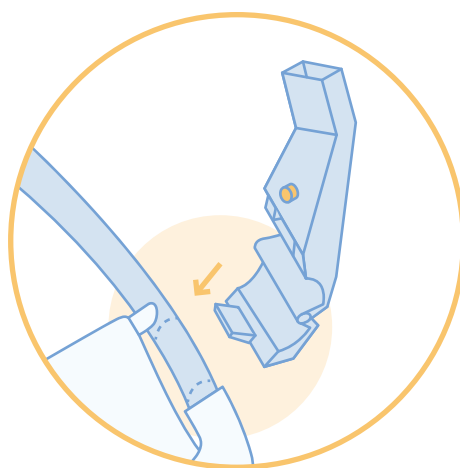
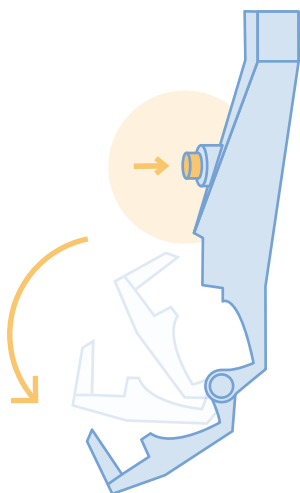

5

Attach the Seats

Attaching the Seats

Place the first seat into the Upper Adapters until it “CLICKS” into a fully locked position. Place the second seat into the Lower Adapters until it “CLICKS” into a fully locked position. Press the white buttons located on the adapters and lift the seats upward to fully remove.

Important!

Remember to always load the upper seat first. After your child is secure in the upper seat, place your second child into the bottom seat



Pro Tip

To fold the stroller with two seats attached please make sure that both seats are facing forward and in the upright reclined positioned. In addition, make sure the brake pedal is pressed down completely before engaging the fold lever on the handlebar.

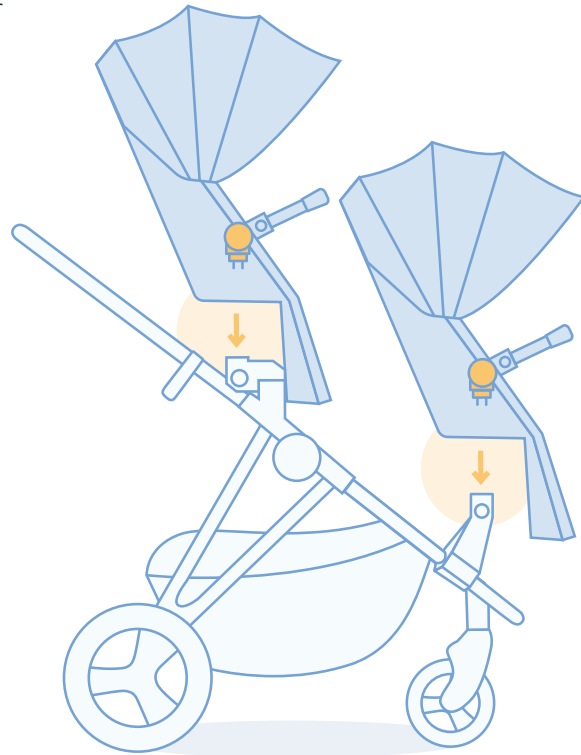

6

Securing your little one

Adjust the Shoulder Straps

Unhook both shoulder straps from the center hub and remove the shoulder pads from the straps.

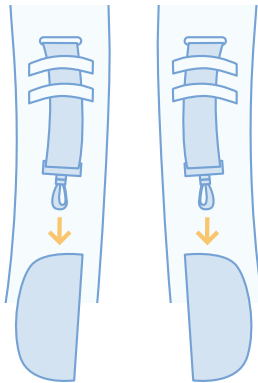

Slide the straps out, upward, and into one of the three shoulder strap positions depending on baby's size.

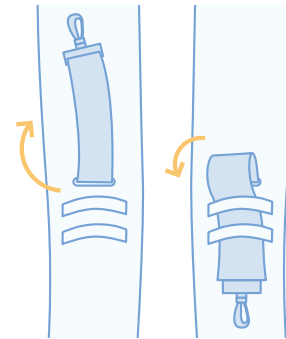

Important!

Before placing your child in the stroller, press the brake pedal down until it “CLICKS” into the locked position. Make sure the brake pedal is pressed down completely.



Pro Tip

Your stroller is preset with the shoulder straps in the lowest position. As your child grows, adjusting the straps upward will make it more comfortable for them.

If you are using an Infant Insert, Footmuff, or Seat Liner, you may need to adjust the straps to the loosest position right away.



Securing your little one (continued)

Place your child in the stroller

Position the crotch belt between their legs. Pull shoulder straps over their arm and shoulder and fasten both strap ends to the restraint system. Fasten both waist belts to the buckle on each side of the crotch belt, and make sure you hear a “click” on both sides. Tighten each waist belt and shoulder strap so that the restraint system is snug.

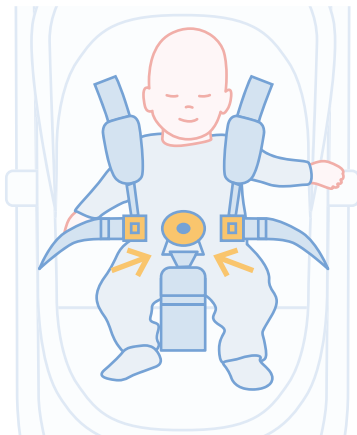

Tighten the Straps

Feed the anchored end of a waist belt up through the buckle to form a loop. Pull the free end of the waist belt. Repeat this procedure to tighten the other waist belt. For the shoulder straps, feed the top end through the plastic stay to form a loop. Pull the bottom end down to tighten the strap. Repeat this procedure to tighten the other shoulder strap.



Pro Tip

Another way to adjust the harness is by adjusting the crotch belt. When using the seat liner or footmuff, it is always best to loosen the crotch belt to the maximum length, and remove the crotch pad if additional room is needed.

7

Arranging the Seats

To Recline the Stroller Seat

Lift the recline latch located on the top center of the stroller seat upward and rotate seat downward. To return to an upright position, lift the recline latch upward and rotate seat upward.



Additional arrangements are available with the addition of the Car Seat Adapter, Infant Seat Insert, or Carriage.

To view all 19+ stroller arrangements, visit: hellomockingbird.com/arrangements

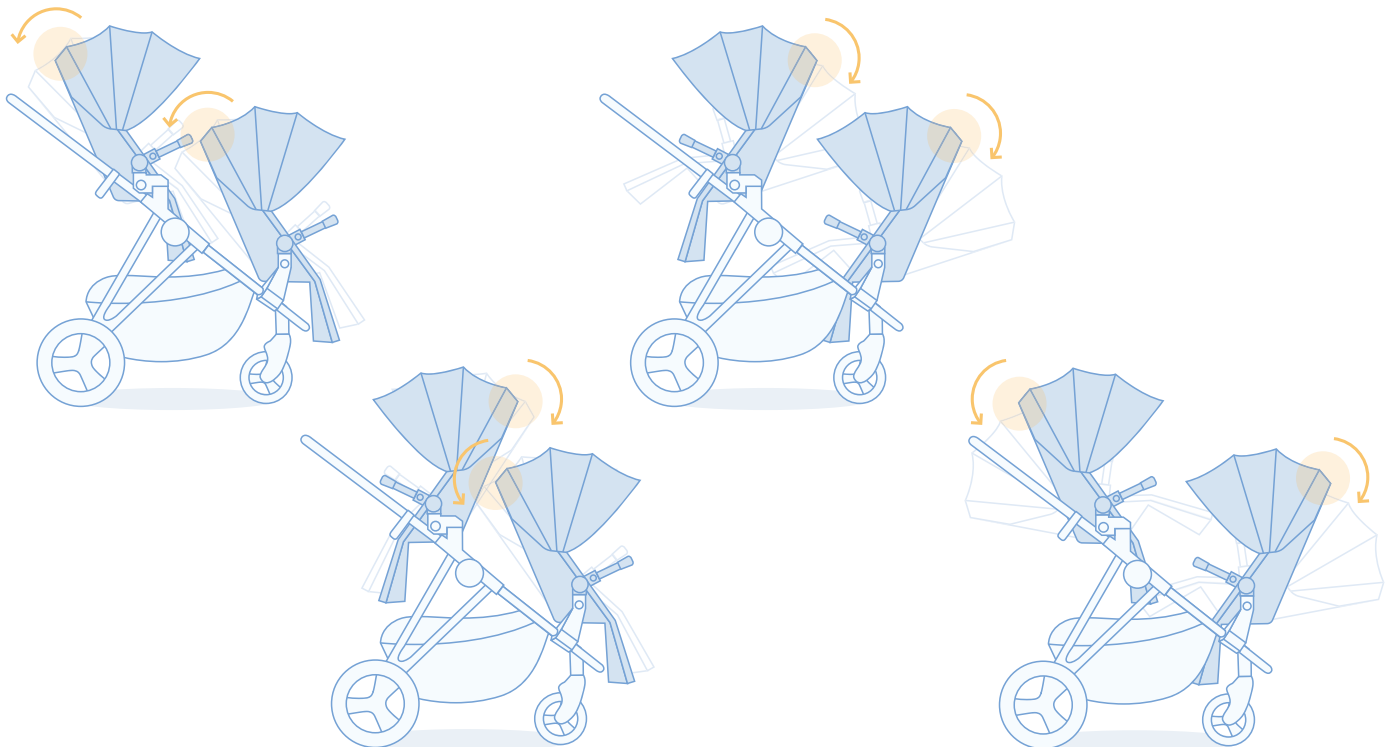

When things get messy

Cleaning the fabric



Hand wash with a damp cloth



Air dry



Do not bleach

Cleaning the plastic



Use mild cleaning solution



Use warm water on a sponge or cloth

Cleaning the sunshade



Machine wash in warm water



Do not bleach



Tumble dry low or hang dry



Do not iron or dry clean

