



Overview

The PolarStar Micro Regulator can be used with any SLP, LP or standard HPA tank designed for Paintball applications. It is safe to use with tanks which output up to 900PSI. The Standard Pressure version provides an output pressure range of 40 to 130PSI. (Note: The output pressure of the regulator can vary slightly depending on the output pressure of the tank it is used with.)

Installation

To install the regulator onto your tank, simply align the threaded base of the regulator with the tank threads and turn clockwise until the regulator is snug. The o-ring on the top of your tank will create a seal against the walls of the regulator body so excessive force is not needed when tightening.

Pressure Adjustment

The pressure adjustment screw is located on the side of the regulator. When you receive your Micro Reg the pressure will be at its lowest setting and will need to be increased to begin use. Using a 3/32 allen wrench, turn the screw clockwise to increase pressure and counter-clockwise to decrease pressure. When decreasing pressure, you will need to either fire your rifle or purge the line before the adjustment registers on your gauge.

Tournament Lock

Secure a zip-tie in the groove around the circumference of the regulator body. The zip-tie blocks access to the head of the adjustment screw.

Maintenance

The Micro Regulator will require periodic cleaning and greasing to maintain top performance. The most basic maintenance is the cleaning of the piston and piston bore. This should be performed every 100,000 to 150,000 cycles or sooner if the recharge rate has slowed or the output pressure has become less consistent.

1. Remove from tank and release pressure from the regulator.
2. Remove the piston bore using a flat head screwdriver or a coin.
3. Remove the piston from the body. Be careful not to scratch or damage the stem of the piston, especially the thin edge, as this can lead to leaks or creeping due to poor sealing.
4. Remove piston o-ring and clean any dirt and old grease from all components.
5. Reinstall o-ring and apply new grease to the o-ring and to the outside of the piston stem in-between the piston head and the through hole.
6. Insert the piston into the piston bore and reinstall both as an assembly into the body.

HPA Safety

High Pressure Air has been used for decades as a source to power Airguns, Paintball Guns and Airsoft Replicas. It is safe and effective to use although there are some precautions that should always be followed while using HPA.

A quick inspection of your Compressed Air Tank should be done before using the tank. Take a look at the top of the valve, the threads and the gauge for any cracks, signs of stress or damaged o-rings. The fill nipple should be clean of debris. A fiber wrapped tank should be free of cracks and serious dings or chips. A few minor scratches can be expected but any chip that reaches the fiber threads underneath the clear resin exterior means that tank is no longer safe to use.

We recommend the use of a paintball tank bottle cover for your HPA tank. Most tank covers are made of neoprene or other material, usually with additional padded sections for extra impact protection.

Know the pressure rating of your tank! It should go without saying but some people still mess this up. At fields with self-fill stations you need to be sure you only fill to the proper pressure. At fields where the staff does the filling you should always mention whether your tank is a 3000 psi or 4500 psi when you hand it to them as a reminder, since they might be filling many tanks quickly between games and sometimes get sidetracked.

Sometimes after getting a fill and disconnecting you might hear a slight hissing from the fill nipple. There is an o-ring on a small check valve inside the fill nipple which may need to be replaced (it's a good idea to carry a spare in your kit bag). Never put any oil or grease in the fill nipple to stop a leak! Oil or grease in the fill nipple will be blasted into a mist form when high pressure air starts rushing through. Tanks heat up when filled to pressure, and if it gets hot enough this oil mist gets can ignite, similar to how a diesel engine combusts. So remember, NEVER PUT ANYTHING IN THE FILL NIPPLE!



PolarStar Airsoft
5 Garfield Way
Newark, DE 19713

cs@polarstarairsoft.com
P: 302-449-4866
F: 302-368-5502

<http://polarstarairsoft.com>
<http://facebook.com/PolarStarAirsoft>
<https://instagram.com/PolarStarAirsoft>

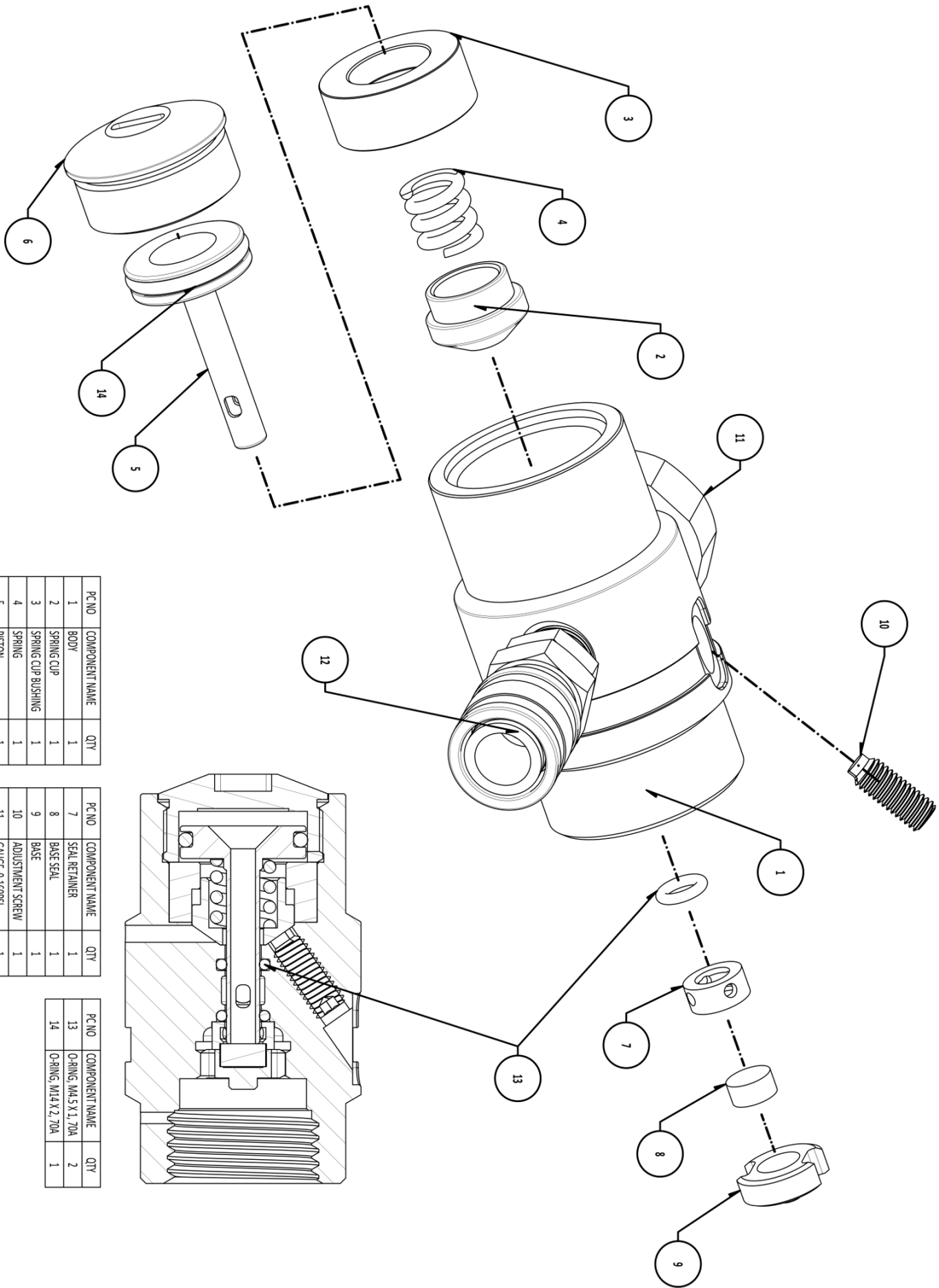

PC NO	COMPONENT NAME	QTY
1	BODY	1
2	SPRING CUP	1
3	SPRING CUP BUSHING	1
4	SPRING	1
5	PISTON	1
6	PISTON BORE	1

PC NO	COMPONENT NAME	QTY
7	SEAL RETAINER	1
8	BASE SEAL	1
9	BASE	1
10	ADJUSTMENT SCREW	1
11	GAUGE, 0-150PSI	1
12	Q.D. FITTING, FEMALE	1

PC NO	COMPONENT NAME	QTY
13	O-RING, MA 5 X 1.70A	2
14	O-RING, M14 X 2.70A	1