

Smoothie Maker

Instructions Instrucciones

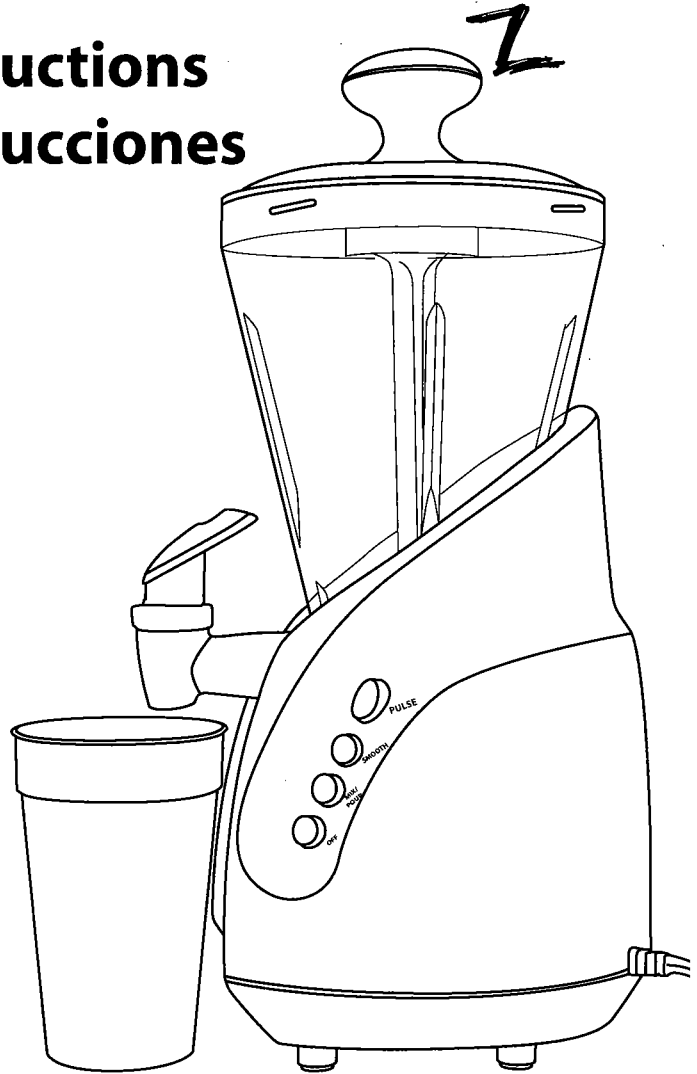

© 2003 Back to Basics Products, Inc.
11660 South State Street, Draper, Utah 84020
All Rights Reserved.
Todos los derechos reservados.
Tous droits réservés.



Housewares for Health
Utensilios para la Salud
Articles Ménagers pour la Santé

English (2-7)

Español (8-13)

Français (14-19)

SMOOTHIE MAKER

Congratulations! We hope you enjoy the hours of healthy fun and delicious smoothies you can make with the Smoothie Maker from Back to Basics. We have designed the Smoothie Maker with you in mind. You will find this unique machine not only easy to use, but fun for the whole family.

Warranty

Your Back to Basics Smoothie Maker is warranted for one year from the date of purchase to be free from mechanical defects in material and workmanship. The manufacturer's obligation is limited to replacing or repairing such defects during the warranty period at no charge, providing the product is sent prepaid to:

Back to Basics Products, Inc.
11660 South State Street
Draper, UT 84020

After repairing or replacing the product, Back to Basics will pay for return postage. This warranty does not cover damage from misuse of this product. If service is required, do not return the product to the store. Do one of the following:

- Send a note to us explaining the problem. Include your name, address, and phone number.
- For faster service, call (801) 571-7349.
- Most service problems are resolved by replacing a broken or defective part. If this is not the case, we will give you instructions for returning the unit.

Smoothie Maker Parts

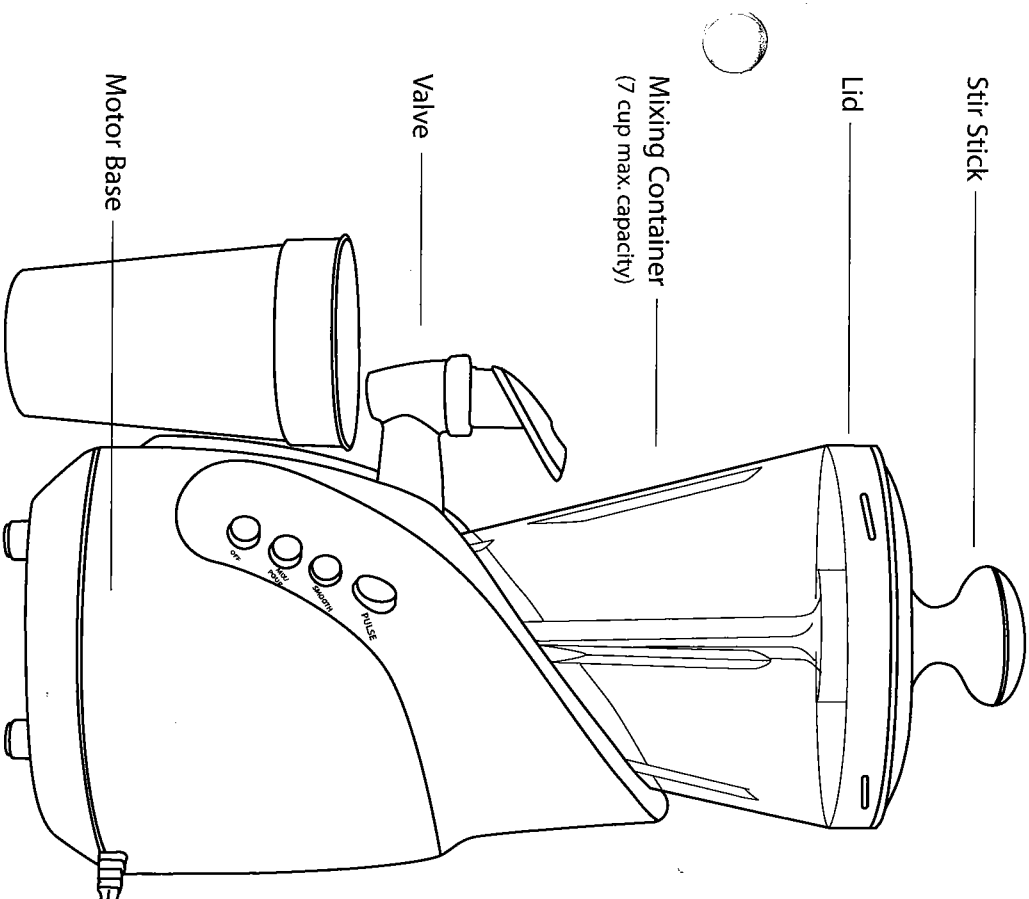

IMPORTANT SAFEGUARDS

When using electrical appliances, basic safety precautions should always be followed including the following:

- Read all instructions before using.
- To protect against electrical shock, do not put cord, plugs, or the motor assembly in water or other liquid.
- Close supervision is necessary when any appliance is used by or near children.
- Unplug from outlet when not in use, before putting on or taking off parts, and before cleaning.
- Avoid contacting moving parts.
- Do not operate any appliance with a damaged cord or plug or after the appliance malfunctions, or is dropped or damaged in any manner. Return appliance to the nearest authorized service facility for examination, repair, or electrical or mechanical adjustment.
- The use of accessory attachments not recommended or sold by the appliance manufacturer may cause fire, electric shock, or injury.
- Do not use outdoors.
- Do not let the cord hang over the edge of a table or counter.
- Do not let the cord contact hot surfaces, including the stove.
- Do not place on or near a hot gas or electrical burner or in a heated oven.
- Do not use appliance for other than intended use.
- Do not place mixing container on motor base while motor is running.
- Do not remove mixing container from motor base while motor is running.
- Keep hands and utensils (other than included Stir Stick) out of container while mixing to reduce risk of severe injury to persons or damage to the machine.
- Blades are sharp, handle carefully.
- To reduce risk of injury, never place cutter assembly blades on base without jar properly attached.

- Always operate blender with the cover in place.
- Do not mix hot liquids.
- Be sure to turn switch to off position after each use.
- To disconnect, grip plug and pull from wall outlet. Never pull on cord.
- Never leave the house while the appliance is on.
- A short cord set is provided to reduce the hazards resulting from becoming entangled in or tripping over a longer cord.
- Extension cords may be used if care is exercised in their use. The marked electrical rating of the extension cord should be at least as great as the electrical rating of the appliance. The extension cord should be arranged so that it will not drape over the countertop where it can be pulled by children or tripped over.
- This appliance has a polarized plug (one blade is wider than the other). To reduce risk of electric shock, this plug will fit in a polarized outlet only on way. If the plug does not fit fully in the outlet, reverse the plug. If it still does not fit, contact a qualified electrician. Do not modify the plug in any way.
- After running motor continuously for three minutes, wait at least five minutes before running the motor again.
- Do not run motor while mixing container is empty.

SAVE THESE INSTRUCTIONS INTENDED FOR HOUSEHOLD USE ONLY.

Care & Cleaning

Before using the first time and after each use, be sure to thoroughly wash the mixing container, valve, lid, and stir stick. To prolong the life of your Smoothie Maker, **do not wash parts in the dish washer**. Open the container valve while washing to rinse out the valve. Occasionally unscrew and disassemble valve for cleaning (see page 5). Also, occasionally remove base for cleaning. Turn it clockwise to remove.

If you experience any problem with your machine, unplug it immediately from the electrical outlet, then contact Back to Basics at 01-571-7349.

Smoothies Made Easy!

The Smoothie maker mixing container is conveniently marked to create perfect smoothies for two or four servings. To make a frozen blend of your favorite healthy foods, follow these simple steps:

Add Liquids

Add any combination of liquid ingredients up to the **LIQUIDS** mark under **SERVES 4** or **SERVES 2**. Liquids include any soft ingredients such as fruit, milk, fruit juice, herbal supplements, or yogurt in any combination you think would be tasty.

We are, of course, partial to the Smoothie Maker smoothie mixes, which quickly and easily make three delicious 8-ounce smoothies.

Add Ice

Add ice or frozen ingredients until the total level reaches the **FROZEN INGREDIENTS** line on the side of the mixing container. Frozen ingredients include ice, frozen fruit, frozen yogurt, ice cream, etc.

Smooth It

With the lid on and the stir stick set in the hole in the lid, press the **MIX** button to get things started. After 30 seconds, go ahead and press the **SMOOTH** button. Continue until smooth. Turn the stir stick counter clockwise for best mixing results.

Serve It

To serve the smoothie, press the **MIX** button, hold a cup under the valve, and press down the valve lever. Stir the smoothie with the stir stick while dispensing thick smoothies. As the smoothie level reaches the bottom of the mixing container, a thick mix may stop dispensing. Add a few tablespoons of liquid to increase flow. When the mixing container is empty, shut off the machine and enjoy.

You can continue making smoothies one after another. When you are finished, be sure to rinse the container, lid, and stir stick. A quick trick for rinsing out the valve is to fill the container half full of water and, with the machine running, drain the water through the valve into a container.

Thicker Smoothie

To make a thicker smoothie, add more frozen ingredients.

Thinner Smoothie

To make a thinner smoothie, add more liquid ingredients.

Smoothie Maker Control Buttons

Pressing the **SMOOTH** button turns on the Smoothie Maker at high speed. This speed should be used for the final stages of mixing. Do not use this speed for pouring. Pressing the **OFF** or **MIX** buttons will pop the **SMOOTH** button up into the off position.

Pressing the **MIX** button turns on the Smoothie Maker at low speed. This speed should be used for the initial 30 seconds of mixing as well as for pouring. Pressing the **OFF** or **SMOOTH** buttons will pop the **MIX** button up into the off position.

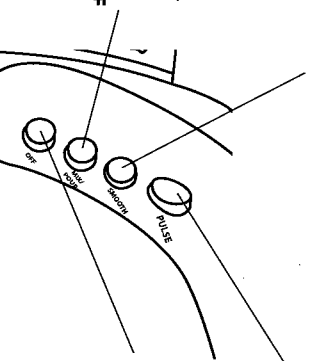

Holding down the **PULSE** button runs the Smoothie Maker at high speed.

Pressing the **OFF** button shuts off the machine when either the **MIX** or **SMOOTH** buttons are in the on position.

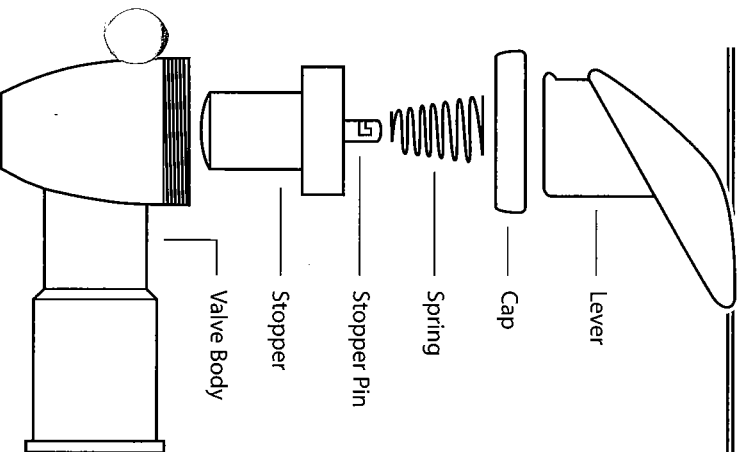

Cleaning Valve

To disassemble valve for cleaning:

1. To remove the valve from the container, unscrew the entire valve counter-clockwise.
2. To remove Lever, push upward on Stopper and slide the Lever off of the Stopper Pin.
3. To remove the Cap, unscrew it counter-clockwise.
4. Remove the Spring.
5. Remove the Stopper and Stopper Pin by pulling the rubber rim of the Stopper. The Stopper and Pin are tightly fit and need not be separated.
6. Clean all parts in warm soapy water and reassemble in the order shown.