

6" LED RETROFIT DOWNLIGHT

POLYCARBONATE TRIM SQUARE DESIGN

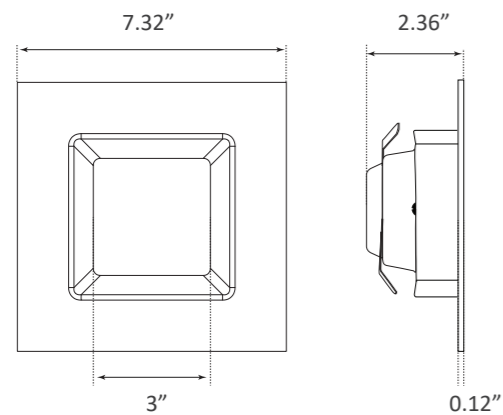

Weight 197g
Dimensions 7.32" x 7.32" x 2.36"

The Parmida LED Technologies™ 6 inch Square Design Downlight is a uniquely modern retrofit light. Manufactured with easy tab installation to provide a simple and secure installation process that is compatible with 6" housing. Made with an impact resistant, fire-rated polycarbonate trim, this product is light, outstandingly tough and maintains its original color over time. It is built with Steady-Dim technology and is compatible with most modern LED dimmers.



DOWNLIGHT

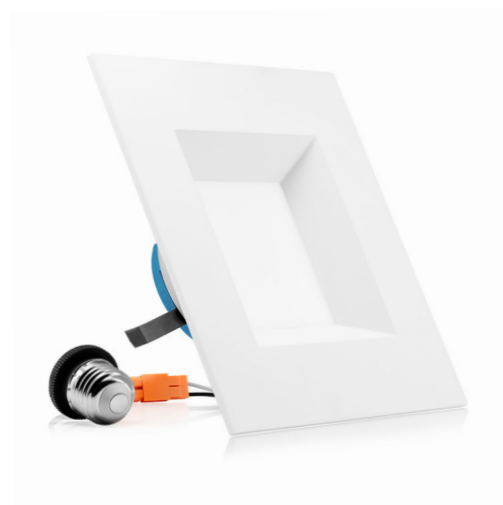

50,000 HOURS



WET LOCATION RATED



120V AC VOLTAGE



950 LUMENS



100 WATT REPLACEMENT



100° BEAM ANGLE



INSTANT ON



NO HUMMING/BUZZING

PRODUCT SPECIFICATIONS

Item Number	PLED-DNSQP612W3K	PLED-DNSQP612W4K	PLED-DNSQP612W5K
Wattage	12W	12W	12W
Lumens	950lm	950lm	950lm
Voltage	120V AC	120V AC	120V AC
Equivalent	100W	100W	100W
Beam Angle	100°	100°	100°
Dimmable	Yes	Yes	Yes
Material	Polycarbonate & Aluminum	Polycarbonate & Aluminum	Polycarbonate & Aluminum
CCT	3000K, Soft White	4000K, Cool White	5000K, Day Light
CRI	>90	>90	>90
LED Driver Type	DOB (Driver on Board)	DOB (Driver on Board)	DOB (Driver on Board)
Base type	E26	E26	E26
Life	50,000 Hours	50,000 Hours	50,000 Hours
Efficiency	88%	88%	88%
Certification	ES, ETL, FCC, JA8	ES, ETL, FCC, JA8	ES, ETL, FCC
Warranty	5 Years	5 Years	5 Years