



4FT T8 TYPE A+B TUBE

PLED-T818W3KV2-AB-CL

PLED-T818W3KV2-AB-F

PLED-T818W4KV2-AB-CL

PLED-T818W4KV2-AB-F

PLED-T818W5KV2-AB-CL

PLED-T818W5KV2-AB-F

PLED-T818W6KV2-AB-CL

PLED-T818W6KV2-AB-F

INSTALLATION MANUAL

WWW.PARMIDA.COM

INSTALLATION INSTRUCTION

WARNING 03

“PLUG & PLAY” INSTALLATION (TYPE A) 03

RETROFIT INSTALLATION (TYPE B) 03

 A. Retrofit luminaire with inductive ballast 04

 B. Retrofit luminaire with electronic ballast 05

 C. Retrofit luminaire with two lamps and one electronic ballast 05

 D. Retrofit luminaire with three lamps and one electronic ballast 06

 E. Retrofit luminaire with four lamps and one electronic ballast 06

BALLAST COMPATIBILITY LIST 08



⚠ WARNING

- Risk of fire or electric shock. When installing with an electronic ballast, please check the compatible ballast list first. If you do not find your ballast on the list, please bypass the fixture. Do not install the LED Tube with a ballast that is not listed on our compatible ballast list – risk of fire.
- Risk of fire or electric shock. LED Retrofit Kit installation requires knowledge of luminaires electrical systems. If not qualified, do not attempt installation. Contact a qualified electrician.
- Risk of fire or electric shock. Install this kit only in the luminaires that have the construction features and dimensions shown in the photographs and/or drawings and where the input rating of the retrofit kit does not exceed the input rating of the luminaire.
- Do not make or alter any open holes in an enclosure of wiring or electrical components during kit installation.
- To prevent wiring damage or abrasion, do not expose wiring to edges of sheet metal or other sharp objects.
- Installers should not disconnect existing wires from lampholder terminals to make new connections at lampholder terminals. Instead installers should cut existing lampholder leads away from the lampholder and make new electrical connections to lampholder lead wires by employing applicable connectors.
- For a linear tubular LED lamp conversion, there shall be text or a diagram showing how the supply connections were made to the lampholders so the correct connections will be made to the lamp when the lamp is installed or replaced.
- This retrofit kit is accepted as a component of a luminaire where the suitability of the combination shall be determined by authorities having jurisdiction.
- If the tube is installed as Type B, the luminaire, once modified as retrofit fixture will no longer operate fluorescent lamps.
- These lamps should be installed by a licensed electrician.
- These lamps are to be used indoors (damp or dry locations only). Not suitable for wet location.
- Under Type B setting this device is not suitable for use with emergency ballasts or dimming ballasts.

“PLUG & PLAY” INSTALLATION (TYPE A)

* Before installation, please check our compatible ballast list and ensure your ballast is listed. If it is not listed, please install your LED tubes according to the Type B Installation Method instructions below.

1. Disconnect power to the light fixture at the breaker panel before installation.
2. Remove the diffuser from the light fixture (if applicable).
3. Remove the existing fluorescent tubes from the light fixture.
4. Install the LED tubes.
5. Install diffuser (if removed in step 2).
6. Switch on power to the light fixture.

“PLUG & PLAY” WIRING DIAGRAM

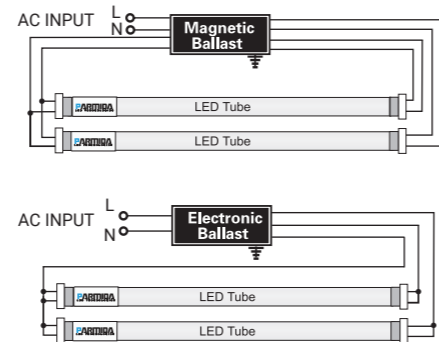

RETROFIT INSTALLATION (TYPE B)

* Can be installed with either single or double ended connection.
* Double-ended connection can be used with either shunted or non-shunted sockets (tombstones). For single-ended connection, please use non-shunted sockets.
Please install your LED tubes according to the Type B Installation Method instructions below.

1. Disconnect power to the light fixture at the breaker panel before installation.
2. Remove the diffuser lens from the light fixture (if applicable).
3. Remove any existing fluorescent tubes by rotating them a one quarter turn and sliding them out.
4. Remove ballast cover (cover may be secured with screws or tabs).
5. Retrofit light fixture according to the diagram applicable to your fixture.

RETROFIT INSTALLATION (TYPE B) CONTD

SINGLE-ENDED CONNECTION

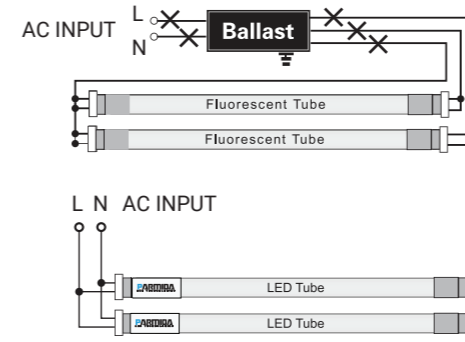

Only use end with label to make single-ended connection

DOUBLE-ENDED CONNECTION

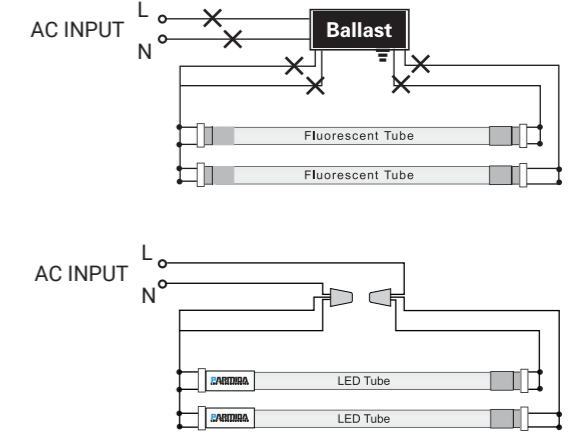

A. Retrofit luminaire with inductive ballast

1. Disconnect the wires between starter and ballast according to the figure.
2. Connect two wires to branch circuit L and N according to the figure.

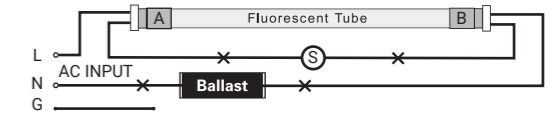

SINGLE-ENDED CONNECTION

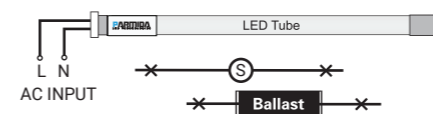

Only use end with label to make single-ended connection

OR

DOUBLE-ENDED CONNECTION

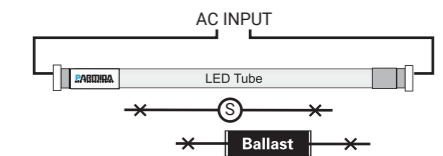

OR

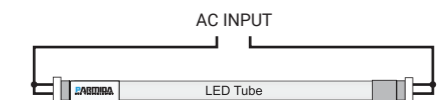

B. Retrofit luminaire with electronic ballast

1. Disconnect the wires between tombstone and ballast according to the figure.
2. Connect two wires to branch circuit L and N according to the figure.

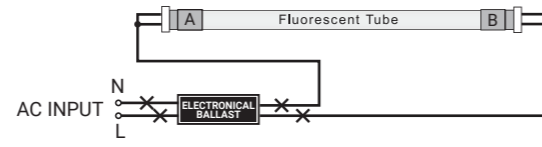

SINGLE - ENDED CONNECTION

OR

DOUBLE - ENDED CONNECTION

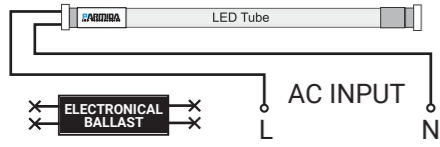

Only use end with label to make single-ended connection

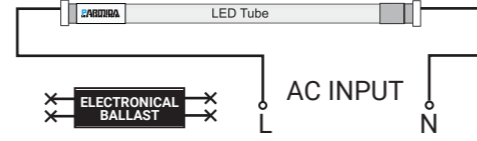

OR

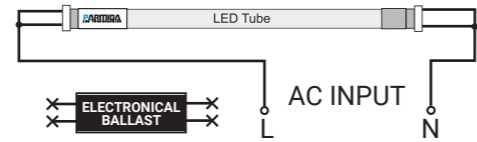

C. Retrofit luminaire with two lamps and one electronic ballast

1. Disconnect the wires between tombstone and ballast according to the figure.
2. Connect two wires to branch circuit L and N according to the figure.

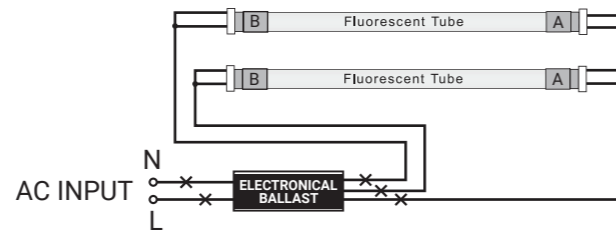

SINGLE - ENDED CONNECTION

OR

DOUBLE - ENDED CONNECTION

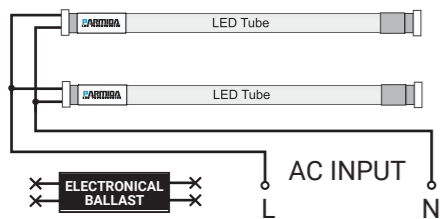

Only use end with label to make single-ended connection

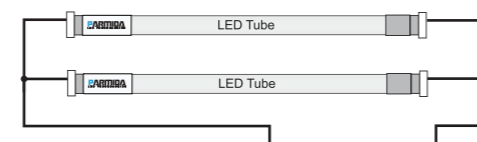

OR

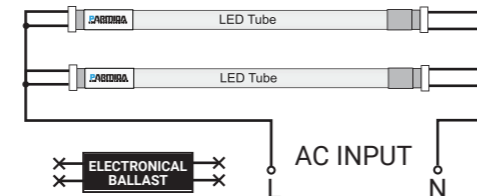

D. Retrofit luminaire with three lamps and one electronic ballast

1. Disconnect the wires between tombstone and ballast according to the figure.
2. Connect two wires to branch circuit L and N according to the figure.

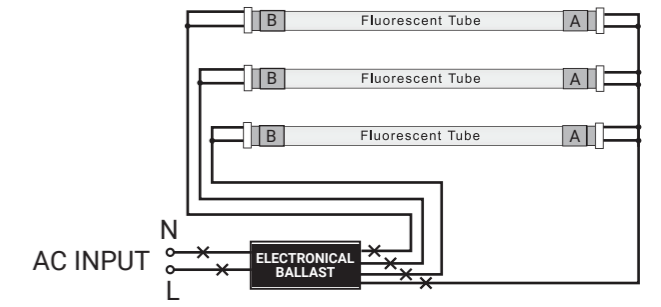

SINGLE - ENDED CONNECTION

OR

DOUBLE - ENDED CONNECTION

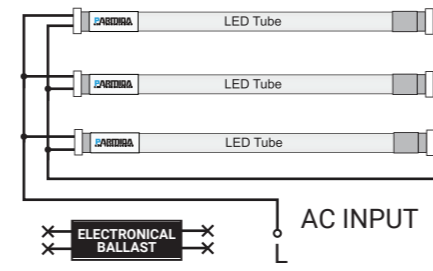

Only use end with label to make single-ended connection

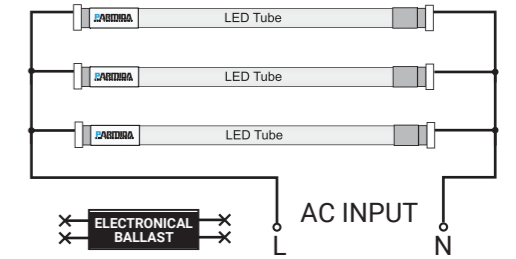

OR

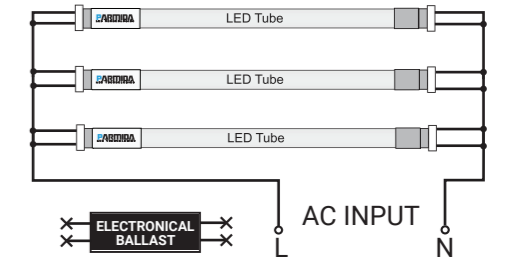

E. Retrofit luminaire with four lamps and one electronic ballast

1. Disconnect the wires between tombstone and ballast according to the figure.
2. Connect two wires to branch circuit L and N according to the figure.

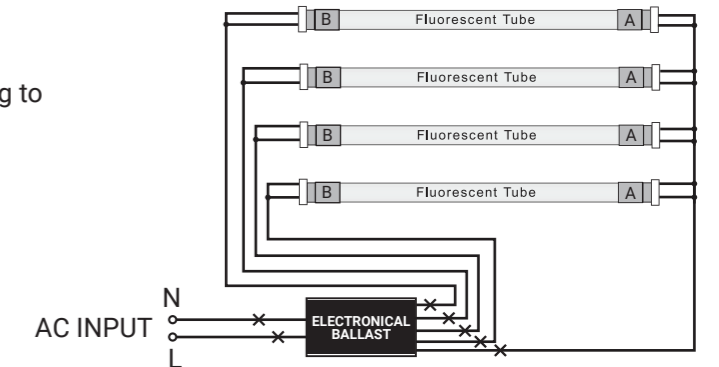

SINGLE - ENDED CONNECTION

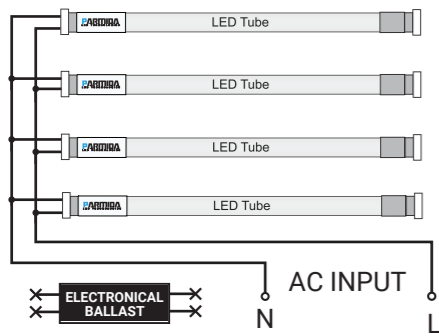

Only use end with label to make single-ended connection

OR

DOUBLE - ENDED CONNECTION

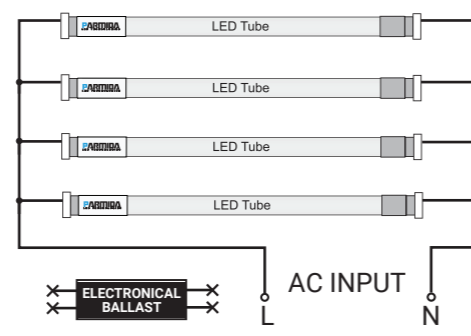

OR

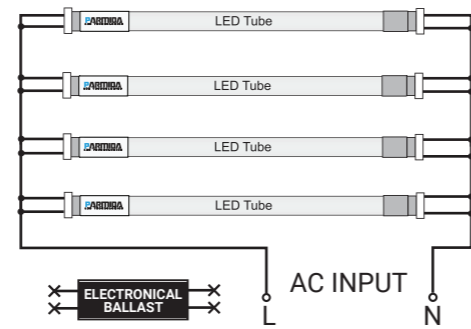

BALLAST COMPATIBILITY LIST. 4FT T8 TYPE A+B TUBE

1. These tubes are compatible with the ballasts listed below. If you intend to install this tube with any ballast not listed below, risk of damage or losses may occur. We are not liable for any damage or losses incurred by not following the instructions in this document.
2. If you do not see the exact model number of your ballast on this list, it means we have not tested the ballast and cannot guarantee that it will work with our T8 tubes. If this is the case for you, we recommend directly wiring your tubes for the best results.

BRAND	MODEL NO.
ACT	ACT3P32ISUNVE
ACT	ATC4P32ISUNVE
DAMAR	3654C
DAMAR	1688B
DAMAR	1688D
EIKO	PM-2X32T8-UNV-IS
ESPEN	VE2P32MVHIPE11068
ESPEN	VE2P32MVHIPHE11069
ESPEN	VE2P32MVHPPE11080
ESPEN	VE4P32MVHPPE11086
ESPEN	VE3P32MVHIPE11070
ESPEN	VE4P32MVHIPE11072
ESPEN	VE432120MIP
ESPEN	EPL3/32IS/MV/SC/HE
ESPEN	VE3P32MVHPPE11083
ESPEN	VE332MVHIPL
ESPEN	VE3P32MVHIPL11056
ESPEN	VE232MVHIPL
ESPEN	VEL-4P32-SC
GE	GE259MAX-G-N
GE	GE132MAX-H/ULTRA
GE	GE232-MV-N
GE	GE332MAX-G-N-DIYB
GE	GE332MAX-G-N
GE	GE232MAX-G-N

BRAND	MODEL NO.
GE	GE232MAX-G-N-DIYB
GE	GE432MAX-G-N
GE	GE259MAX-G-N-DIYB
GE	GE432MAXG-N-DIYL
GE	GE132-MVPS-H
GE	GE232-120RES-B
GE	GE-132-MV-N
GE	GE332MAX-G-H
GE	GE132MAX-G-347
GE	GE432MAXP347-N
GE	GE232MAX-G-N-DIYL
GE	GE-232-MV-N
GE	GE132MAXP-L/ULTRA
HALCO	EP2/32IS/MV/MC/HE
HALCO	EPL2/32IS/MV/MC/HE
HALCO	EPH4/32IS/MV/SC/HE
HALCO	EP232IS/MV/HE
HALCO	EP432IS/MV/MC/HE
HALCO	EP432ISUNVE
HALCO	EP332IS/MV/HE
HALCO	EP4/32IS/MVMC/HE
HALCO	EP432IS/L/MV/HE
HALCO	EPL4/32IS/MV/MC/HE
KEystone	KTEB-432-UV-IS-N-P
KEystone	KTEB-332-UV-IS-N-P

6. Insert LED tubes
 - a. Read the label on the LED tube to ensure the power end of the LED is aligned with the powered tube socket, then insert the LED tube by sliding pins into sockets and rotating a quarter turn until the LED tube locks in place.
 - b. LED lamps are now fully installed.
7. Replace the diffuser lens of the light fixture (if applicable).
8. After modification completed. Attach the Replacement Marking and Cautionary Label to a visible place on the luminaire and keep it visible after installation.
9. Restore power to the circuit/luminaire and test the light. If necessary, adjust position of the LED tube(s).

BRAND	MODEL NO.
KEYSTONE	KTEB-232-UV-IS-N-P
KEYSTONE	KTEB-126-1-TP-LC/A
KEYSTONE	KTEB-232-UV-IS-N-P
OSRAM SYLVANIA	QTP4X32T8/UNV ISN-SC
OSRAM SYLVANIA	QHE 2X32T8/UNV PSN-MC
OSRAM SYLVANIA	QTP2X32T8/UNV ISN-SC
OSRAM SYLVANIA	QTP 3X32T8/UNV ISN-SC
OSRAM SYLVANIA	QHE2X32T8/UNV ISN-SC
OSRAM SYLVANIA	QHE 4X32T8/UNV ISN-SC
OSRAM SYLVANIA	QHE4XLED32T8/UNV ISN-SC
OSRAM SYLVANIA	QHE 3XLED32T8/UNV ISN-SC
OSRAM SYLVANIA	QHE2X59T8/UNV ISL-SC
OSRAM SYLVANIA	QHE 1X32T8/UNV ISN-SC
OSRAM SYLVANIA	QHE1X32T8/UNV ISL-SC
PHILIPS ADVANCE	IOP-2P59-N
PHILIPS ADVANCE	ICN-1P32-N
PHILIPS ADVANCE	ICN-2P32-N
PHILIPS ADVANCE	ICN-3P32-N
PHILIPS ADVANCE	ICN-4P32-N
PHILIPS ADVANCE	IOP-2PSP32-N
PHILIPS ADVANCE	REZ-2S32-SC
PHILIPS ADVANCE	IOPA-2P32-LW-N

BRAND	MODEL NO.
PHILIPS ADVANCE	IOP-4PSP32-SC
PHILIPS ADVANCE	IOPA-2P32-N
PHILIPS ADVANCE	IOPA-3P32-N
PHILIPS ADVANCE	IOPA-4P32-N
PLUSRITE	BAF232IS/MV
PLUSRITE	BAF332IS/MV
ROBERTSON	ISL432T8HEMV3P20160
SUNLITE	40155-SU.SB/232/MV
UITRASAVE	UT 232347
UNIVERSAL	B432IUNVHE-A
UNIVERSAL	B232IUNVHP-N
UNIVERSAL	B232IUNVHP-N
UNIVERSAL	B432IUNVHP-A
UNIVERSAL	B432PUNVHE-A
UNIVERSAL	B232PUNVHE-B
UNIVERSAL	B332IUNVHP-A
UNIVERSAL	B432IUNVHE-A
UNIVERSAL	B332IUNVEL-A
UNIVERSAL	QHE 3X32T8/UNV ISH HT-SC
UNIVERSAL	B232IUNVHEH-A
UNIVERSAL	B332IUNVHE-A

WARNING: Please note that Parmida LLC is not responsible for any problems occurring from installation with any ballast model number not found on our compatible ballast list . Any subsequent issues resulting from installation with a non-listed ballast will not be covered under our warranty.